



**YCRS
WATER COOLED REMOTE CONDENSER UNITS**



**81 TONS THROUGH 194 TONS
285 kW THROUGH 682 kW
60Hz
STYLE A**



ALLY

Contents

<i>Introduction</i>	3
<i>Specifications</i>	4
<i>Accessories & Options</i>	7
<i>Design Parameters</i>	9
<i>Pressure Drops</i>	10
<i>Selection Data</i>	12
<i>Ratings (R-22 English)</i>	14
<i>Ratings- (R-22 SI)</i>	18
<i>Part Load Ratings</i>	20
<i>Physical Data</i>	22
<i>Isolator Selection Data</i>	23
<i>Isolator Details</i>	24
<i>Sound Data</i>	25
<i>Dimensions (English)</i>	26
<i>Dimensions (SI)</i>	28
<i>Electrical Data (Multi-Point Wiring)</i>	30
<i>Incoming Wire Range (Multi-point)</i>	32
<i>Incoming Wire Range (Single Point)</i>	35
<i>Customer Wiring Data</i>	36
<i>Typical Control Panel Wiring</i>	38
<i>Application Data</i>	40
<i>Guide Specifications</i>	41

Nomenclature

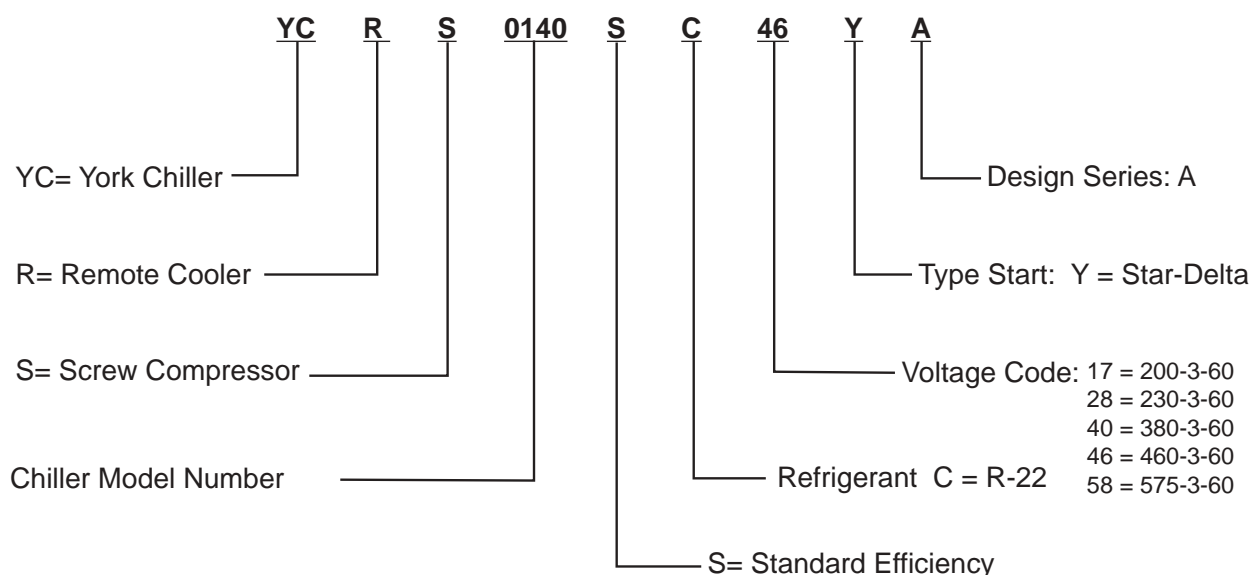

York YCRS Water Cooled Screw Chillers



YORK YCRS Remote Condenser models provide chilled water for all air conditioning applications that use central station air handling or terminal units. They are completely self-contained and are designed for indoor (new or retrofit) installation. Each unit includes accessible semi-hermetic screw compressors, a liquid cooler, remote air-cooled condenser, and a user-friendly, diagnostic Microcomputer Control Center all mounted on a rugged steel base. The YCRS units are produced at an ISO 9001 registered facility, and are rated in accordance with ARI Standard 550/590-98.*

* Remote Condenser Models provide peak performance when used with matching YORK air cooled condensers. Refer to Form 195.21-EG2.

Specifications

GENERAL

The Liquid Chiller will be completely assembled with all interconnecting refrigerant piping and internal wiring, ready for field installation. The unit can be covered with an optional coat of Caribbean Blue enamel overspray.

The unit will be pressure-tested, evacuated, and charged with dry Nitrogen (N₂) for shipment, and York 'L' (POE) synthetic oil. The discharge and liquid lines will be capped and plugged. They will be removed in the field when connecting this unit with an air-cooled condenser. There will be an operational test, with water flowing through the cooler, to check that each control device operates correctly.

Units are designed in accordance with NFPA 70 (National Electric Code), U.L. and cU.L. Standards, ASHRAE/ANSI 15 Safety Code for Mechanical Refrigeration. All units are produced at an ISO 9001 registered facility. All YCRS chillers are rated in accordance with ARI Standard 550/590-98 at ARI conditions.

SEMI-HERMETIC YORK SCREW COMPRESSORS

- Continuous function, microprocessor controlled, 3-way proportional Capacity Control Valve provides regulated output pressure independent of valve input pressure for a stable, smooth, and precise match of compressor capacity to cooling load to 10% of chiller capacity.
- Automatic spring return of capacity control valve to minimum load position ensures compressor starting at minimum motor load. Internal discharge check to prevent rotor backspin upon shutdown.
- Acoustically tuned, internal discharge gas path eliminates objectionable noise at the source, while optimizing flow for maximum performance.
- Reliable suction gas cooled, high efficiency, accessible hermetic motor with APT2000 type magnet wire and redundant overload protection using both thermistor and current overload protection.
- Suction gas screen and serviceable, 0.5 micron full flow oil filter within the compressor housing.
- Cast iron compressor housing precisely machined for optimal clearances and superb efficiency. Entire compressor, from suction to discharge has a Design Working Pressure of 450psig (31 bar).

- 350W compressor body cartridge heater.
- Each compressor will be mounted on isolator pads to reduce transmission of vibration to the rest of the unit.

COOLER

The dual-circuit cooler will be the direct-expansion type, with refrigerant in the tubes and chilled liquid flowing through the baffled shell. The design working pressure of the shell (liquid) side will be 150 PSIG (10.3 bar), and 300 PSIG (26.7 bar) for the tube (refrigerant) side.

The cooler will be constructed and tested in accordance with the applicable sections of the ASME Pressure Vessel Code, Section VIII, Division (1). The water side will be exempt per paragraph U-1, (c)(6).

The water baffles will be constructed of galvanized steel to resist corrosion. The removable heads will allow access to the internally enhanced, seamless, copper tubes. Vent and drain connections will be included.

The cooler will be covered with 3/4" (19.1 mm) flexible, closed-cell, foam insulation (K = 0.25).

REFRIGERANT CIRCUIT

Two independent refrigerant circuits will be furnished on each unit. All piping will be copper with brazed joints. The liquid lines will be capped before the liquid dryer angle valve and will include: a shutoff valve with charging port; sightglass with moisture indicator; thermal expansion valve; solenoid valve; and high-absorption removable-core filter drier. The entire suction line and the liquid line between the expansion valve and the cooler will be insulated with flexible, closed-cell, foam insulation.

POWER AND CONTROL PANELS

All controls and motor starting equipment necessary for unit operation shall be factory wired and function tested. The panel enclosures shall be designed to NEMA 1 (IP 32) and manufactured from powder-painted galvanized steel.

The Power and Control Panel shall be divided into a power section for each electrical system, a common input section and a control section.

Each power panel shall contain:

Compressor starting contactors, control circuit serving compressor capacity control, compressor contactor coils and compressor motor overloads. The compressor motor overloads contain current transform-

ers which sense each phase, as an input to the microprocessor, to protect the compressor motors from damage due to: low input current, high input current, unbalanced current, single phasing, phase reversal, and compressor locked rotor.

The common input section shall contain:

The control supply transformer providing 115V, customer relay board and control circuit switch disconnect/emergency stop device.

The control section shall contain:

On/Off rocker switch, microcomputer keypad and display, microprocessor board, I/O expansion board, relay boards, and 24V fused power supply board.

MICROPROCESSOR CONTROLS

Fuzzy Logic control will be incorporated in the YCRS range of chillers. Fuzzy Logic allows the control system to monitor several key variables to provide tighter, more stable chilled water temperature control. The control system monitors the leaving chilled water temperature to track where it has been, where it is now, how fast it is moving, and accurately adjusts the chiller operation in anticipation of expected performance to minimize hunting and save energy.

The microprocessor shall have the following functions and displays:

- A liquid crystal 40 character display with text provided on two lines and light emitting diode backlighting for outdoor viewing.
- A color-coded, 35 button, sealed keypad with sections for Display, Entry, Setpoints, Clock, Print, Program, and Unit On/Off Switch.

The standard controls shall include: brine chilling or thermal storage, automatic pumpdown, run signal contacts, demand load limit from external building automation system input, remote reset liquid temperature reset input, unit alarm contacts, chilled liquid pump control, automatic reset after power failure, automatic system optimization to match operating conditions, software stored in non-volatile memory (EPROM) to eliminate chiller failure due to AC power failure.

The microprocessor can be directly connected to a YORK ISN Building Automation System via the standard onboard RS485 communications port. This option also provides open system compatibility with other communications networks.

Programmed Setpoints shall be retained in a lithium battery backed RTC with a memory of five years.

Display - In Imperial (°F and PSIG) or SI (°C and BAR) units, and for each circuit:

- Return and leaving chilled liquid
- Day, date and time. Daily start/stop times. Holiday and Manual Override status.
- Compressor operating hours and starts. Automatic or manual lead/lag. Lead compressor identification.
- Run permissive status. No cooling load condition. Compressor run status.
- Anti-recycle timer and anti-coincident start timer status per compressor.
- Suction (and suction superheat), discharge, and oil pressures and temperatures per System.
- Percent full load compressor motor current per phase and average per phase. Compressor capacity control valve input steps.
- Cutout status and setpoints for: supply fluid temperature, low suction pressure, high discharge pressure and temperature, high oil temperature, low and high current, phase rotation safety, and low leaving liquid temperature.
- Unloading limit setpoints for high discharge pressure and compressor motor current.
- Liquid pull-down rate sensitivity (0.5°F to 5°F [0.3°C to 3.0°C]/minute in 0.1°F [0.05°C] increments).
- Status of: evaporator heater, load and unload timers, chilled water pump.
- Out of range message.
- Up to 6 fault shut down conditions.
- Standard Display Language is English, with an Option for Spanish.

Entry - Enter set point changes, cancel inputs, advance day, change AM/PM.

Set Points - Chilled liquid temperature, chilled liquid range, remote reset temperature range.

Clock - Time, daily or holiday start/stop schedule, manual override for servicing.

Print - Operating data or system fault shutdown history for last six faults. Printouts through an RS-232 port via a separate printer (by others).

Program -

- Low leaving liquid temperature cutout, 300 to 600 second anti-recycle timer, lag compressor start time delay, and average motor current unload point. Liquid temperature setpoint reset signal from **YORK ISN** or building automation system (by others) via:

Specifications (Continued)

- Pulse width modulated (PWM) input for up to 40°F (22°C) total reset as standard.
- Optional Building Automation System interface input card for up to 20°F (11.1°C) reset using a: 4 to 20 mA, 0 to 10 Vdc input, or discrete reset input.
- NOTE: The Standard MicroPanel can be directly connected to a YORK ISN Building Automation System via the standard onboard RS485 communication port. This Option also provides open system compatibility with other communications networks (BACnet™ & LONMARK™ via interface through standard onboard 485 or 232 port and an external YorkTalk Translator.
- Additional functions (password protected) for programming by a qualified service technician:

Cutouts for low suction pressure, high discharge pressure, high oil temperature.

Refrigerant type.

High discharge pressure unload setpoint.

Compressor motor current percent limit.

The YCRS Chillers are equipped with output relays to cycle condenser fans. Each refrigerant system is equipped with 3 relays. These output relays will stage the condenser fans on/off based on the discharge pressure. As the discharge pressure increases, more fans are commanded ON. As the discharge pressure decreases, fans are commanded OFF. For additional details, refer to the IOM and the Wiring Diagram.

Accessories & Options

ELECTRICAL OPTIONS:

MULTIPLE POINT POWER SUPPLY CONNECTION -

Standard field power wiring connection on all models is Multiple Point Power Connection to factory provided Terminal Blocks. Two field supplied electrical power circuits with appropriate branch circuit protection provide power to each of two motor control center cabinets, located on either side of the Control panel on the front of the chiller. Each cabinet contains starter elements for one compressor.

Optional to the Terminal Blocks for field power connection are Non-Fused Disconnects or Circuit Breaker Switches with external, lockable handles.

SINGLE POINT POWER CONNECTION -

(Factory Mounted) An optional configuration for field connection of a single electrical circuit to: either Terminal Block or Non-Fused Disconnect Switch with lockable external handle (in compliance with Article 440 of N.E.C., to isolate unit power supply for service). Factory wiring is provided from the Terminal Block or Disconnect Switch to Factory supplied individual system Circuit Breakers, Non-Fused Disconnect switch with external, lockable handle or J Class Fuses/Fuse Block in each of the two compressor motor control centers. (Note: Single Point Non-Fused Disconnect Switch will not be supplied with individual system Non Fused Disconnect Switches with external, lockable handles in each of the two compressor motor control centers).

65 Ka HIGH VOLTAGE PROTECTION - Non-Fused Disconnect Switch with fuses (200 & 575V) or Circuit Breakers (230, 380, & 460V) are used for applications where customers have a requirement for single point wiring with high "fault current" withstanding capability. This option provides between 50Ka and 65Ka withstand protection to the equipment.

BUILDING AUTOMATION SYSTEM INTERFACE (Factory Mounted) – Provides means to reset the leaving chilled liquid temperature or percent full load amps (current limiting) from the BAS (Factory Mounted):

- Printed circuit board to accept 4 to 20 milliamp, 0 to 10 VDC, or dry contact closure input from the BAS.
- A YORK ISN Building Automation System can provide a Pulse Width Modulated (PWM) signal direct to the standard control panel via the standard on-board RS485 port.

FLOW SWITCH – The flow switch or its equivalent must be furnished with each unit. 150 PSIG (10.5 bar) DWP – For standard units. Johnson Controls model F61MG-1C Vapor-proof SPDT, NEMA 4X switch (150 PSIG [10.5 bar]

DWP), -20°F to 250°F- (29°C to 121°C), with 1" NPT connection for upright mounting in horizontal pipe. (Field mounted)

DIFFERENTIAL PRESSURE SWITCH - Alternative to the above mentioned Flow Switch. Pretemco Model DPS 300A-P4OPF-82582-S (20.7bar max working pressure). SPDT 5 amp 125/250 VAC switch. Range: 0 - 2.8bar, deadband: 0.003 - 0.005bar, with 1/4 NPTE pressure connections.

LANGUAGE LCD AND KEYPAD - Standard display language and keypad is in English. Spanish is available as an option.

PRINTER KIT - Printer for obtaining printout of unit operating and history data. (Field Mounted)

MULTIPLE UNIT SEQUENCE CONTROL (Field Mounted)

- Sequencing Control with automatic unit sequencing. Necessary items for operation and control of up to eight units with parallel water circuits. Includes software and mixed liquid temperature sensor (interconnecting wiring by others).

PRESSURE VESSEL CODES - Coolers can be supplied in conformance with the following pressure codes: A.S.M.E. (Standard)

FINAL PAINT - The unit can be painted with an optional coat of Caribbean Blue overspray paint. (Factory)

CHICAGO CODE RELIEF VALVES (Factory Mounted) - Unit will be provided with relief valves to meet Chicago Code requirements.

OPTIVIEW PANEL - (Contact York PA Marketing)

ACCESSORIES:

FLANGES (Weld Type) – Consists of 150 PSI (10.5 bar) standard cooler (150 lb) R.F. flanges to convert to flanged cooler-connections and includes companion flanges. (Field mounted)

FLANGES (Victaulic Type) – Consists of (2) Flange adapter for grooved end pipe (standard 150 PSI [10.5 bar] cooler). Includes companion flanges. (Field mounted)

VIBRATION ISOLATION:

- **Neoprene Isolators** – Recommended for normal installations. Provides very good performance in most applications for the least cost. (Field mounted)

-
- **1" Spring Isolators** – Level adjustable, spring and cage type isolators for mounting under the unit base rails. 1" nominal deflection may vary slightly by application. (Field mounted)
 - **2" Seismic Spring Isolators** – Restrained Spring-Flex Mountings incorporate a rugged welded steel housing with vertical and horizontal limit stops. Housings are designed to withstand a minimum 1.0g loads to 10,000 lbs (4,536 kg) and static deflections to 2" (5 cm). Level adjustable, deflection may vary slightly by application. (Field-mounted)

ALTERNATIVE CHILLED FLUID APPLICATIONS:

Standard water chilling application range is 40°F to 50°F (4.4°C to 10°C) Leaving Chilled Water Temperature. To protect against nuisance safety trips below 40°F (4.4°C) and reduce the possibility of cooler damage due to freezing during chiller operation, the unit microprocessor automatically unloads the compressors at abnormally low

suction temperature (pressure) conditions, prior to safety shutdown.

- **Process Brine Option** – Process or other applications requiring chilled fluid below 40°F (4.4°C) risk water freezing in the evaporator, typically overcome by using antifreeze. For these applications, the chiller system incorporates brine (ethylene or propylene glycol solution), and the system design Leaving Chilled Fluid Temperature must be provided on the order form to ensure proper factory configuration.
- **Thermal Storage Option** – Thermal Storage equires special capabilities from a chiller, including the ability to ‘charge’ an ice storage tank, then possibly automatically reset for operation at elevated Leaving Chilled Fluid Temperatures as required by automatic building controls. The Thermal Storage Option provides Ice Storage duty Leaving Chilled Fluid setpoints from 25°F to 15°F (-4°C to -10°C) minimum during charge cycle, with a Reset range of 36°F (20°C) supply fluid temperature.

Design Parameters

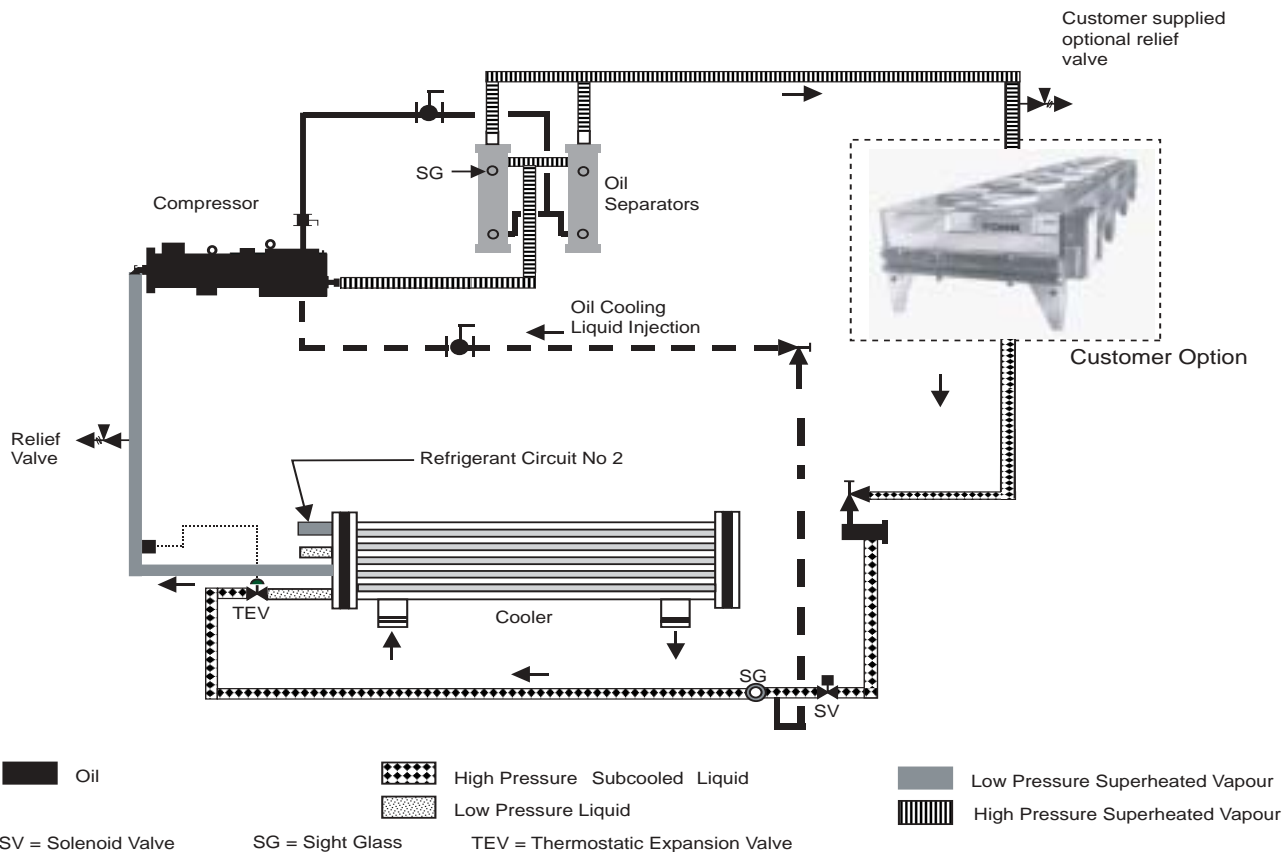

Low-pressure liquid refrigerant enters the cooler tubes and is evaporated and superheated by the heat energy absorbed from the chilled liquid passing through the cooler shell. Low-pressure vapor enters the compressor where pressure and superheat are increased. High-pressure vapor is passed through the oil separator where heat is rejected to a remote condenser (optional VCB). The fully condensed and subcooled liquid leaves the condenser and enters the expansion valve, where pressure reduction and further cooling take place. The low pressure liquid refrigerant then returns to the cooler. Each refrigerant circuit utilizes liquid injection, maintaining efficient oil temperature operation within the compressor.

English

YCRS	0100SC	0120SC	0140SC	0180SC	0200SC	0220SC	0240SC
Min. Cooler Water Flow - GPM	200	200	200	260	260	300	300
Max. Cooler Water Flow - GPM	506	506	506	695	695	830	830
Min. Lvg. Liquid Temp. - °F	40	40	40	40	40	40	40
Max. Lvg. Liquid Temp. - °F	50	50	50	50	50	50	50
Min. Equipment Room Temp. - °F	40	40	40	40	40	40	40
Max. Equipment Room Temp. - °F	115	115	115	115	115	115	115

SI

YCRS	0100SC	0120SC	0140SC	0180SC	0200SC	0220SC	0240SC
Min. Cooler Water Flow - l/sec	12.6	12.6	12.6	16.4	16.4	18.9	18.9
Max. Cooler Water Flow - l/sec	31.9	31.9	31.9	43.8	43.8	52.4	52.4
Min. Lvg. Liquid Temp. - °C	4.4	4.4	4.4	4.4	4.4	4.4	4.4
Max. Lvg. Liquid Temp. - °C	10.0	10.0	10.0	10.0	10.0	10.0	10.0
Min. Equipment Room Temp. - °C	4.4	4.4	4.4	4.4	4.4	4.4	4.4
Max. Equipment Room Temp. - °C	46.1	46.1	46.1	46.1	46.1	46.1	46.1

Pressure Drops

FIGURE 1 - COOLER WATER PRESSURE DROP CURVES (ENGLISH)

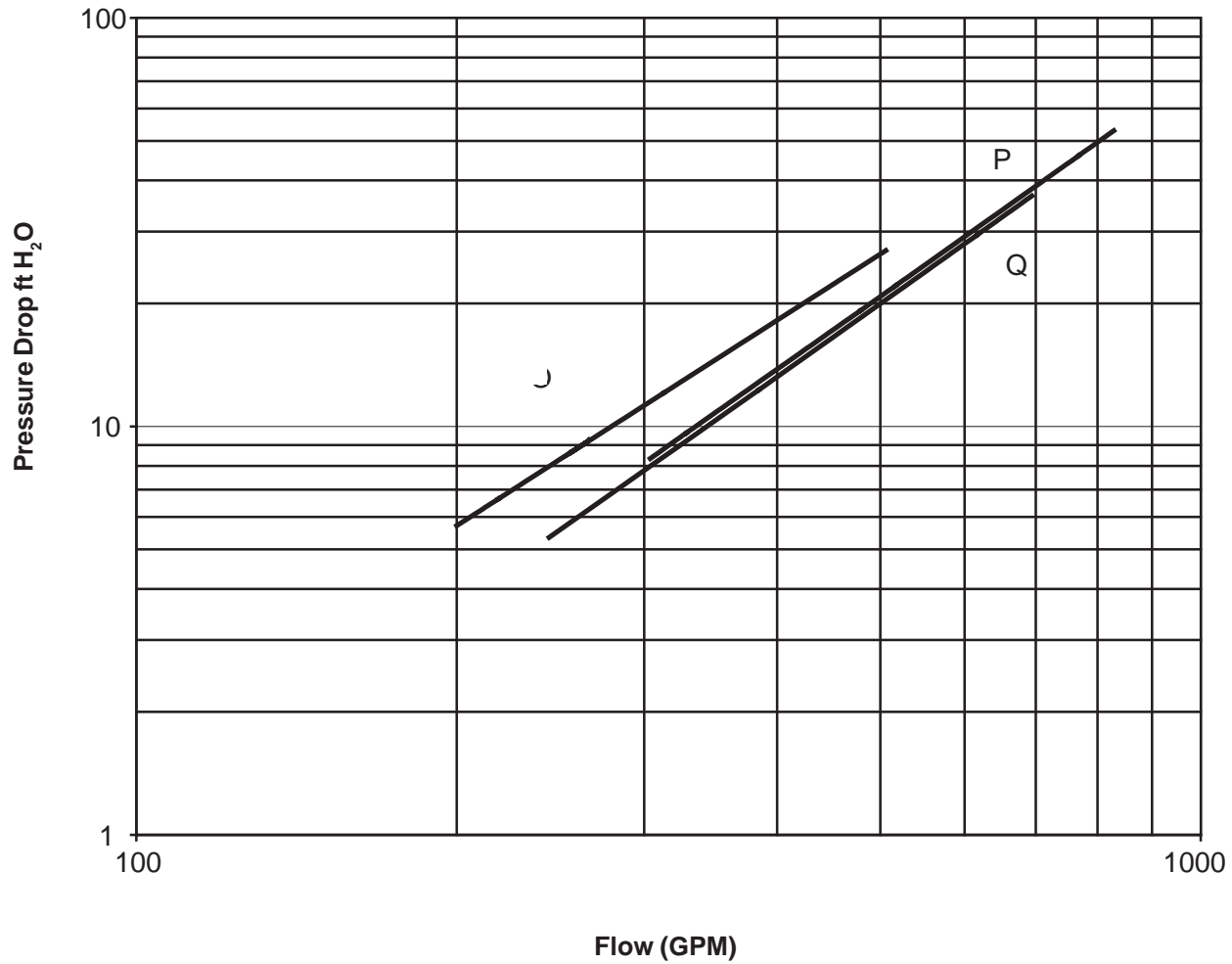

YCRS Model Number	Cooler
0100SC, 0120SC, 0140SC	O
0180SC, 0200SC	P
0220SC, 0240SC	Q

FIGURE 2 - COOLER WATER PRESSURE DROP CURVES (SI)

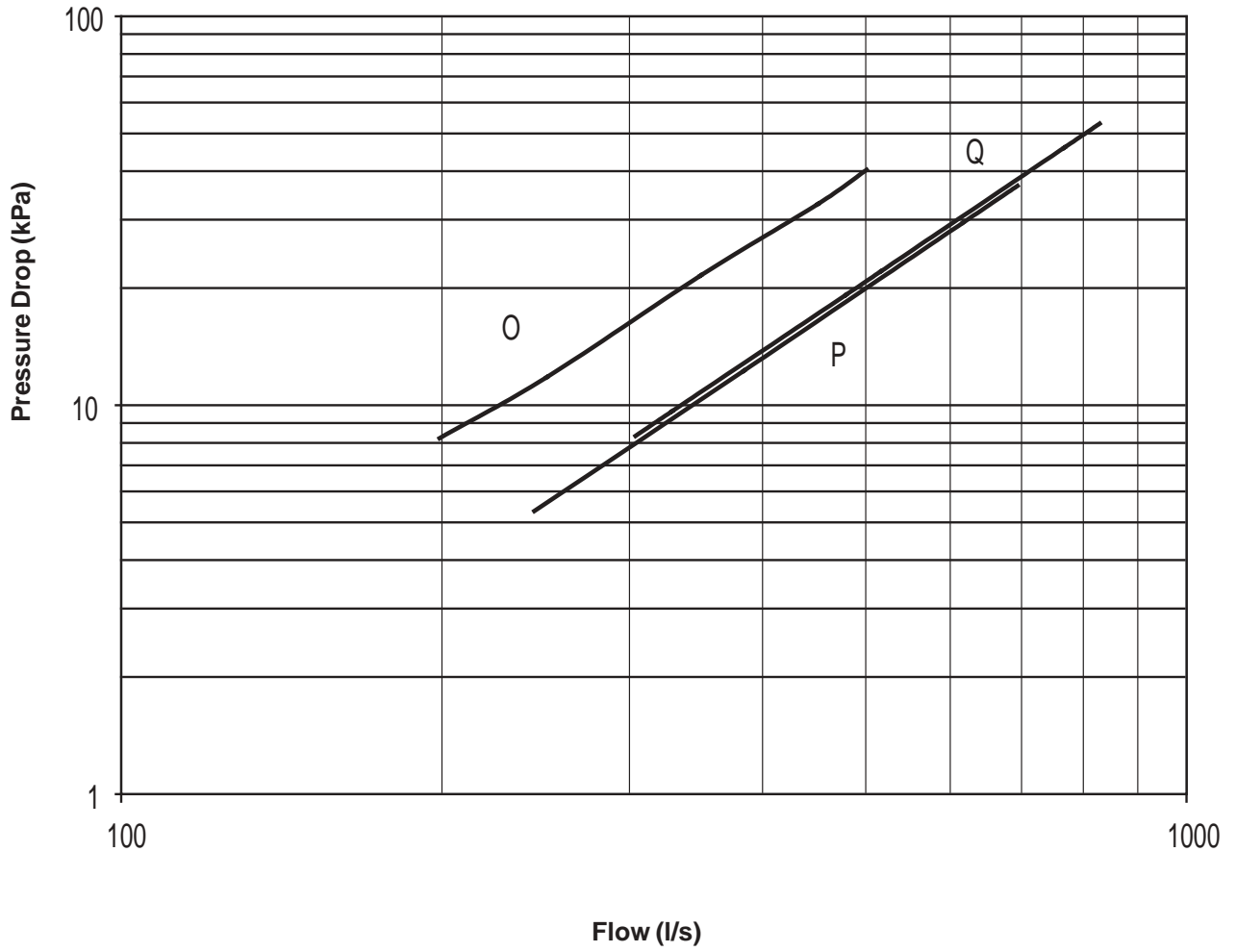

YCRS Model Number	Cooler
0100SC, 0120SC, 0140SC	O
0180SC, 0200SC	P
0220SC, 0240SC	Q

Selection Data

GUIDE TO SELECTION

Complete water chilling capacity ratings for YORK YCRS chillers are shown on the following pages to cover the majority of job requirements. For any application beyond the scope of this Engineering Guide, consult your nearest YORK Office.

SELECTION RULES

- RATINGS** - YCRS 200, 230 380, 460 & 575-3-60 are rated in accordance with ARI standard 550/590, at the ARI standard condition. These ratings may be interpolated but should not be extrapolated.
- COOLING WATER QUANTITY** - Ratings are based on 10°F chilled water range. Use the chilled water correction factors (below) for other ranges except as limited by water pressure drop, minimum or maximum water flows for the cooler.
- FOULING FACTORS** – Rating are based on 0.0001 evaporator. For other fouling factors, consult the table below or contact your YORK representative.

EVAP FOULING FACTORS

Temp Split	0.0001		x	0.00025	
	Tons	Compr kW		Tons	Compr kW
6	0.9692	1.0015		0.9972	1.0001
8	0.9849	1.0008		0.9980	1.0001
10	1.0000	1.0000		0.9982	1.0001
12	1.0133	0.9993		0.9978	1.0001
14	1.0248	0.9986		0.9979	1.0001

Note: Temperature split factors @ 44°F Leaving Chilled Liquid Temp (LCLT)

METHOD OF SELECTION - SAMPLE

- GIVEN** – Cool 230 GPM water from 54°F to 44°F with 0.0001 fouling factor using an air cooled condenser and 60 Hz.

Sat. Discharge Temperature of 125°F

- FIND** – Unit Size
kW Input
Cooler Pressure Drop
Condenser Heat Rejection
EER
- $$TR = \frac{(GPM) (Chilled\ Water\ Range\ ^\circ F)}{24} = \frac{(230) (10)}{24} = 95.8\ Tons$$
- Enter Ratings at:
44°F Cooler Leaving Water Temperature
125°F Saturated Discharge Temperature
- READ** – For a YCRS0120SC:
Tons = 100.7
kW Input = 121.8
- Determine average full load kW, EER and MBH at 95.8 Tons:
$$\frac{95.8}{100.7} (121.8\ kW) = 115.9\ kW$$

$$EER = \frac{95.8\ Tons \times 12}{115.9\ kW} = 9.9$$

MBH of Heat Rejection =
$$(95.8\ Tons \times 12) + (115.9\ kW \times 3.415) = 1545\ MBH$$
- From the curves on page 10, determine the pressure drop with 200 GPM through the cooler of the Model YCRS0120SC.

Cooler Pressure Drop at 230 GPM = 6.7 ft H₂O

INTENTIONALLY LEFT BLANK

Ratings (R-22 English)

LCWT (°F)	SATURATED DISCHARGE TEMPERATURE (°F)															
	95.0				100.0				105.0				110.0			
	TONS	KW	MBH	EER	TONS	KW	MBH	EER	TONS	KW	MBH	EER	TONS	KW	MBH	EER

YCRS0100SC

40.0	93.0	69.0	1351.0	16.2	89.6	73.5	1326.0	14.6	86.4	78.4	1304.0	13.2	83.3	83.6	1285.0	12.0
42.0	96.8	68.8	1396.0	16.9	93.3	73.3	1369.0	15.3	89.9	78.2	1345.0	13.8	86.7	83.5	1325.0	12.5
44.0	100.6	68.6	1442.0	17.6	97.0	73.2	1413.0	15.9	93.4	78.1	1387.0	14.4	90.1	83.4	1366.0	13.0
45.0	102.6	68.5	1465.0	18.0	98.8	73.1	1435.0	16.2	95.3	78.0	1409.0	14.7	91.9	83.3	1387.0	13.2
46.0	104.6	68.4	1488.0	18.4	100.7	72.9	1458.0	16.6	97.1	77.9	1430.0	15.0	93.7	83.2	1407.0	13.5
48.0	108.6	68.1	1535.0	19.1	104.6	72.7	1503.0	17.3	100.8	77.7	1474.0	15.6	97.2	83.1	1450.0	14.0
50.0	112.7	67.8	1584.0	20.0	108.6	72.4	1550.0	18.0	104.6	77.5	1520.0	16.2	100.9	82.9	1493.0	14.6

YCRS0120SC

40.0	114.9	81.7	1657.0	16.9	110.7	87.1	1626.0	15.3	106.8	93.0	1599.0	13.8	103.1	99.2	1576.0	12.5
42.0	119.6	81.9	1714.0	17.5	115.2	87.3	1680.0	15.8	111.1	93.2	1651.0	14.3	107.2	99.6	1626.0	12.9
44.0	124.3	82.0	1771.0	18.2	119.8	87.5	1735.0	16.4	115.5	93.4	1704.0	14.8	111.4	99.8	1678.0	13.4
45.0	126.7	82.0	1800.0	18.5	122.1	87.5	1763.0	16.7	117.7	93.5	1731.0	15.1	113.6	99.9	1704.0	13.6
46.0	129.2	82.0	1830.0	18.9	124.4	87.6	1792.0	17.1	120.0	93.6	1759.0	15.4	115.8	100.0	1730.0	13.9
48.0	134.0	82.0	1888.0	19.6	129.2	87.6	1849.0	17.7	124.6	93.7	1814.0	16.0	120.2	100.2	1784.0	14.4
50.0	139.1	82.0	1949.0	20.4	134.1	87.6	1908.0	18.4	129.3	93.7	1871.0	16.6	124.7	100.3	1839.0	14.9

YCRS0140SC

40.0	136.9	94.4	1964.0	17.4	131.9	100.7	1927.0	15.7	127.3	107.6	1894.0	14.2	122.9	114.9	1866.0	12.8
42.0	142.3	94.9	2032.0	18.0	137.2	101.3	1992.0	16.3	132.4	108.2	1958.0	14.7	127.8	115.7	1928.0	13.3
44.0	148.0	95.4	2101.0	18.6	142.6	101.8	2059.0	16.8	137.6	108.8	2022.0	15.2	132.9	116.3	1991.0	13.7
45.0	150.9	95.5	2136.0	19.0	145.4	102.0	2092.0	17.1	140.3	109.1	2055.0	15.4	135.4	116.6	2022.0	13.9
46.0	153.8	95.7	2172.0	19.3	148.1	102.2	2126.0	17.4	142.9	109.3	2088.0	15.7	138.0	116.9	2055.0	14.2
48.0	159.7	96.0	2244.0	20.0	153.9	102.6	2196.0	18.0	148.3	109.7	2154.0	16.2	143.2	117.4	2119.0	14.6
50.0	165.8	96.1	2317.0	20.7	159.6	102.8	2266.0	18.6	153.9	110.0	2223.0	16.8	148.6	117.8	2185.0	15.1

YCRS0180SC

40.0	164.9	108.3	2349.0	18.3	158.8	115.6	2300.0	16.5	153.1	123.5	2258.0	14.9	147.8	132.0	2224.0	13.4
42.0	171.7	108.9	2431.0	18.9	165.3	116.2	2380.0	17.1	159.4	124.2	2336.0	15.4	153.8	132.8	2298.0	13.9
44.0	178.5	109.3	2515.0	19.6	171.7	116.7	2459.0	17.7	165.7	124.8	2415.0	15.9	160.0	133.5	2375.0	14.4
45.0	182.0	109.5	2558.0	20.0	175.3	116.9	2503.0	18.0	169.0	125.0	2454.0	16.2	163.0	133.7	2413.0	14.6
46.0	185.6	109.6	2600.0	20.3	178.7	117.1	2544.0	18.3	172.3	125.3	2494.0	16.5	166.2	134.0	2451.0	14.9
48.0	192.7	109.8	2686.0	21.1	185.6	117.4	2628.0	19.0	178.9	125.6	2576.0	17.1	172.6	134.5	2530.0	15.4
50.0	200.1	109.9	2776.0	21.9	192.7	117.6	2713.0	19.7	185.7	125.9	2658.0	17.7	179.1	134.9	2610.0	15.9

NOTES:

1. Tons = Unit Cooling Capacity Output
2. kW = Compressor Input Power
3. MBH = Condenser heat rejection
4. EER = Chiller Energy Efficiency Ratio (Capacity [Tons x 12] ÷ kW)
5. LCWT = Leaving Chilled Water Temperature
6. Ratings based on 2.4 GPM cooler water per ton

LCWT (°F)	SATURATED DISCHARGE TEMPERATURE (°F)															
	115.0				120.0				125.0				130.0			
	TONS	KW	MBH	EER	TONS	KW	MBH	EER	TONS	KW	MBH	EER	TONS	KW	MBH	EER

YCRS0100SC

40.0	80.5	89.2	1270.0	10.8	77.8	95.2	1258.0	9.8	75.2	101.6	1249.0	8.9	72.8	108.4	1244.0	8.1
42.0	83.7	89.1	1308.0	11.3	80.9	95.2	1295.0	10.2	78.3	101.6	1285.0	9.2	75.8	108.4	1279.0	8.4
44.0	87.0	89.0	1348.0	11.7	84.1	95.1	1333.0	10.6	81.4	101.6	1323.0	9.6	78.8	108.4	1315.0	8.7
45.0	88.7	89.0	1368.0	12.0	85.7	95.1	1353.0	10.8	82.9	101.5	1341.0	9.8	80.3	108.4	1333.0	8.9
46.0	90.4	88.9	1388.0	12.2	87.4	95.0	1372.0	11.0	84.5	101.5	1360.0	10.0	81.9	108.4	1352.0	9.1
48.0	93.9	88.8	1429.0	12.7	90.7	95.0	1412.0	11.5	87.8	101.5	1399.0	10.4	85.0	108.5	1390.0	9.4
50.0	97.4	88.7	1471.0	13.2	94.1	94.9	1453.0	11.9	91.0	101.5	1439.0	10.8	88.2	108.6	1429.0	9.7

YCRS0120SC

40.0	99.6	106.0	1556.0	11.3	96.3	113.2	1541.0	10.2	93.2	120.8	1530.0	9.3	90.3	128.8	1523.0	8.4
42.0	103.6	106.4	1605.0	11.7	100.1	113.6	1589.0	10.6	96.9	121.3	1577.0	9.6	93.9	129.4	1568.0	8.7
44.0	107.6	106.7	1656.0	12.1	104.1	114.0	1638.0	11.0	100.7	121.8	1624.0	9.9	97.6	130.0	1615.0	9.0
45.0	109.7	106.8	1681.0	12.3	106.1	114.2	1662.0	11.2	102.7	122.0	1648.0	10.1	99.5	130.3	1638.0	9.2
46.0	111.8	107.0	1707.0	12.5	108.1	114.3	1687.0	11.3	104.6	122.2	1672.0	10.3	101.4	130.5	1662.0	9.3
48.0	116.0	107.2	1758.0	13.0	112.2	114.7	1738.0	11.7	108.6	122.6	1722.0	10.6	105.3	131.0	1710.0	9.6
50.0	120.4	107.4	1811.0	13.5	116.5	115.0	1790.0	12.2	112.7	123.0	1772.0	11.0	109.2	131.5	1759.0	10.0

YCRS0140SC

40.0	118.7	122.8	1844.0	11.6	114.8	131.1	1825.0	10.5	111.2	140.0	1812.0	9.5	107.8	149.3	1803.0	8.7
42.0	123.5	123.6	1903.0	12.0	119.4	132.1	1884.0	10.9	115.6	141.0	1869.0	9.8	112.1	150.5	1859.0	8.9
44.0	128.3	124.4	1964.0	12.4	124.1	132.9	1943.0	11.2	120.2	142.0	1927.0	10.2	116.5	151.6	1915.0	9.2
45.0	130.8	124.7	1995.0	12.6	126.5	133.3	1973.0	11.4	122.5	142.5	1956.0	10.3	118.8	152.1	1944.0	9.4
46.0	133.3	125.0	2026.0	12.8	128.9	133.7	2003.0	11.6	124.8	142.9	1986.0	10.5	121.0	152.6	1973.0	9.5
48.0	138.4	125.6	2089.0	13.2	133.8	134.4	2064.0	11.9	129.6	143.7	2045.0	10.8	125.6	153.6	2031.0	9.8
50.0	143.5	126.1	2152.0	13.6	138.8	135.1	2126.0	12.3	134.4	144.5	2106.0	11.2	130.2	154.5	2090.0	10.1

YCRS0180SC

40.0	142.8	141.0	2194.0	12.1	138.0	150.6	2170.0	11.0	133.6	160.8	2151.0	10.0	129.4	171.6	2138.0	9.0
42.0	148.5	141.9	2266.0	12.6	143.6	151.7	2240.0	11.4	139.0	162.0	2220.0	10.3	134.6	172.9	2205.0	9.3
44.0	154.4	142.7	2340.0	13.0	149.3	152.6	2312.0	11.7	144.5	163.1	2290.0	10.6	139.9	174.1	2273.0	9.6
45.0	157.4	143.1	2377.0	13.2	152.2	153.0	2348.0	11.9	147.3	163.6	2325.0	10.8	142.7	174.7	2308.0	9.8
46.0	160.5	143.4	2415.0	13.4	155.1	153.4	2385.0	12.1	150.1	164.1	2361.0	11.0	145.4	175.3	2343.0	10.0
48.0	166.6	144.0	2491.0	13.9	161.1	154.2	2459.0	12.5	155.9	165.0	2433.0	11.3	151.0	176.4	2414.0	10.3
50.0	173.0	144.6	2569.0	14.4	167.1	154.9	2534.0	13.0	161.8	165.8	2507.0	11.7	156.7	177.4	2486.0	10.6

NOTES:

1. Tons = Unit Cooling Capacity Output
2. kW = Compressor Input Power
3. MBH = Condenser heat rejection
4. EER = Chiller Energy Efficiency Ratio (Capacity [Tons x 12] ÷ kW)
5. LCWT = Leaving Chilled Water Temperature
6. Ratings based on 2.4 GPM cooler water per ton

Ratings (R-22 English) - Cont.

LCWT (°F)	SATURATED DISCHARGE TEMPERATURE (°F)															
	95.0				100.0				105.0				110.0			
	TONS	KW	MBH	EER	TONS	KW	MBH	EER	TONS	KW	MBH	EER	TONS	KW	MBH	EER

YCRS0200SC

40.0	187.4	121.8	2664.0	18.5	180.5	129.9	2609.0	16.7	173.9	138.8	2561.0	15.0	168.0	148.3	2522.0	13.6
42.0	195.2	122.4	2760.0	19.1	187.9	130.6	2700.0	17.3	181.2	139.6	2650.0	15.6	174.9	149.2	2608.0	14.1
44.0	203.0	122.9	2855.0	19.8	195.5	131.2	2794.0	17.9	188.5	140.3	2741.0	16.1	181.9	150.0	2694.0	14.5
45.0	206.9	123.0	2903.0	20.2	199.3	131.5	2841.0	18.2	192.0	140.5	2783.0	16.4	185.3	150.3	2737.0	14.8
46.0	210.9	123.2	2952.0	20.5	203.1	131.7	2886.0	18.5	195.9	140.8	2831.0	16.7	189.0	150.7	2782.0	15.1
48.0	219.1	123.4	3050.0	21.3	211.0	132.0	2983.0	19.2	203.4	141.3	2923.0	17.3	196.3	151.2	2871.0	15.6
50.0	227.4	123.5	3151.0	22.1	219.0	132.2	3080.0	19.9	211.1	141.6	3017.0	17.9	203.7	151.7	2962.0	16.1

YCRS0220SC

40.0	204.6	134.0	2912.0	18.3	197.2	143.0	2854.0	16.5	190.2	152.8	2803.0	14.9	183.5	163.2	2759.0	13.5
42.0	213.0	134.7	3015.0	19.0	205.1	143.8	2952.0	17.1	197.8	153.6	2898.0	15.5	190.8	164.2	2849.0	13.9
44.0	221.2	135.2	3115.0	19.6	213.4	144.4	3054.0	17.7	205.6	154.4	2994.0	16.0	198.5	165.1	2946.0	14.4
45.0	225.9	135.4	3172.0	20.0	217.6	144.7	3104.0	18.0	209.6	154.7	3043.0	16.3	202.4	165.5	2993.0	14.7
46.0	230.2	135.6	3225.0	20.4	221.8	144.9	3155.0	18.4	213.8	155.0	3094.0	16.6	206.3	165.8	3041.0	14.9
48.0	239.1	135.8	3333.0	21.1	230.3	145.3	3260.0	19.0	222.0	155.5	3195.0	17.1	214.1	166.4	3137.0	15.4
50.0	248.2	136.0	3442.0	21.9	239.1	145.5	3365.0	19.7	230.4	155.8	3297.0	17.7	222.3	166.9	3237.0	16.0

YCRS0240SC

40.0	221.3	146.2	3154.0	18.2	213.2	156.1	3091.0	16.4	205.2	166.6	3031.0	14.8	198.3	178.1	2987.0	13.4
42.0	230.3	146.9	3264.0	18.8	221.9	156.9	3198.0	17.0	213.5	167.6	3133.0	15.3	206.5	179.2	3089.0	13.8
44.0	239.4	147.5	3377.0	19.5	230.7	157.6	3306.0	17.6	222.4	168.4	3244.0	15.8	214.1	180.0	3184.0	14.3
45.0	244.1	147.8	3433.0	19.8	235.2	157.9	3361.0	17.9	226.8	168.8	3297.0	16.1	218.8	180.5	3242.0	14.5
46.0	248.0	147.9	3481.0	20.1	239.8	158.1	3417.0	18.2	231.1	169.1	3351.0	16.4	223.0	180.9	3294.0	14.8
48.0	260.1	148.3	3627.0	21.0	249.0	158.5	3529.0	18.8	240.1	169.6	3459.0	17.0	231.6	181.6	3399.0	15.3
50.0	268.3	148.4	3726.0	21.7	256.5	158.7	3620.0	19.4	249.1	170.0	3570.0	17.6	240.4	182.2	3506.0	15.8

NOTES:

1. Tons = Unit Cooling Capacity Output
2. kW = Compressor Input Power
3. MBH = Condenser heat rejection
4. EER = Chiller Energy Efficiency Ratio (Capacity [Tons x 12] ÷ kW)
5. LCWT = Leaving Chilled Water Temperature
6. Ratings based on 2.4 GPM cooler water per ton

LCWT (°F)	SATURATED DISCHARGE TEMPERATURE (°F)															
	115.0				120.0				125.0				130.0			
	TONS	KW	MBH	EER	TONS	KW	MBH	EER	TONS	KW	MBH	EER	TONS	KW	MBH	EER

YCRS0200SC

40.0	162.4	158.5	2490.0	12.3	157.0	169.3	2462.0	11.1	152.0	180.8	2441.0	10.1	147.2	192.9	2425.0	9.2
42.0	169.0	159.5	2572.0	12.7	163.3	170.4	2542.0	11.5	158.1	182.1	2519.0	10.4	153.2	194.4	2502.0	9.5
44.0	175.7	160.4	2655.0	13.1	169.8	171.5	2623.0	11.9	164.4	183.3	2598.0	10.8	159.2	195.7	2579.0	9.8
45.0	179.1	160.8	2698.0	13.4	173.1	172.0	2665.0	12.1	167.6	183.8	2638.0	10.9	162.3	196.4	2618.0	9.9
46.0	182.5	161.2	2741.0	13.6	176.5	172.5	2706.0	12.3	170.8	184.4	2679.0	11.1	165.5	197.0	2658.0	10.1
48.0	189.6	161.9	2827.0	14.0	183.2	173.3	2790.0	12.7	177.4	185.4	2761.0	11.5	171.8	198.3	2738.0	10.4
50.0	196.7	162.5	2915.0	14.5	190.2	174.1	2876.0	13.1	184.0	186.4	2844.0	11.8	178.3	199.4	2820.0	10.7

YCRS0220SC

40.0	177.3	174.4	2722.0	12.2	171.3	186.3	2691.0	11.0	165.8	198.9	2669.0	10.0	160.7	212.3	2652.0	9.1
42.0	184.4	175.5	2812.0	12.6	178.1	187.5	2777.0	11.4	172.5	200.4	2754.0	10.3	167.2	213.9	2736.0	9.4
44.0	191.4	176.5	2899.0	13.0	185.4	188.7	2869.0	11.8	179.4	201.7	2841.0	10.7	173.8	215.4	2821.0	9.7
45.0	195.5	177.0	2950.0	13.3	189.0	189.3	2914.0	12.0	182.7	202.3	2883.0	10.8	177.2	216.1	2864.0	9.8
46.0	199.2	177.4	2996.0	13.5	192.5	189.8	2958.0	12.2	186.4	202.9	2929.0	11.0	180.6	216.8	2908.0	10.0
48.0	206.9	178.2	3091.0	13.9	199.8	190.7	3048.0	12.6	193.5	204.1	3019.0	11.4	187.6	218.2	2995.0	10.3
50.0	214.7	178.9	3187.0	14.4	207.5	191.6	3144.0	13.0	200.8	205.1	3109.0	11.7	194.6	219.5	3084.0	10.6

YCRS0240SC

40.0	191.6	190.3	2948.0	12.1	185.3	203.3	2918.0	10.9	179.3	217.0	2892.0	9.9	173.8	231.6	2876.0	9.0
42.0	199.3	191.5	3045.0	12.5	192.6	204.6	3010.0	11.3	186.7	218.6	2986.0	10.2	180.6	233.3	2964.0	9.3
44.0	207.3	192.6	3145.0	12.9	200.2	205.9	3106.0	11.7	193.9	220.0	3078.0	10.6	187.8	235.0	3055.0	9.6
45.0	211.4	193.1	3195.0	13.1	204.4	206.5	3157.0	11.9	197.6	220.7	3124.0	10.7	191.7	235.8	3105.0	9.8
46.0	215.4	193.6	3246.0	13.4	208.3	207.1	3206.0	12.1	201.5	221.4	3173.0	10.9	195.4	236.6	3152.0	9.9
48.0	223.7	194.4	3348.0	13.8	216.3	208.1	3306.0	12.5	209.3	222.7	3272.0	11.3	202.9	238.1	3247.0	10.2
50.0	232.1	195.2	3451.0	14.3	224.4	209.1	3406.0	12.9	217.2	223.8	3370.0	11.6	210.5	239.4	3343.0	10.5

NOTES:

1. Tons = Unit Cooling Capacity Output
2. kW = Compressor Input Power
3. MBH = Condenser heat rejection
4. EER = Chiller Energy Efficiency Ratio (Capacity [Tons x 12] ÷ kW)
5. LCWT = Leaving Chilled Water Temperature
6. Ratings based on 2.4 GPM cooler water per ton

Ratings- (R-22 SI)

LCWT (°C)	SATURATED DISCHARGE TEMPERATURE (°C)															
	30.0				35.0				40.0				45.0			
	KW _o	KW _i	KW	COP	KW _o	KW _i	KW	COP	KW _o	KW _i	KW	COP	KW _o	KW _i	KW	COP

YCRS0100SC

5.0	354.8	61.7	416.0	5.8	331.2	68.9	400.0	4.8	309.8	77.3	387.0	4.0	290.4	86.9	377.0	3.3
6.0	367.7	61.6	429.0	6.0	343.2	68.8	412.0	5.0	321.1	77.2	398.0	4.2	300.9	86.8	387.0	3.5
7.0	380.9	61.4	442.0	6.2	355.5	68.6	424.0	5.2	332.5	77.0	409.0	4.3	311.6	86.7	398.0	3.6
8.0	394.4	61.1	455.0	6.5	368.0	68.4	436.0	5.4	344.1	76.9	420.0	4.5	322.5	86.6	409.0	3.7
9.0	408.1	60.8	468.0	6.7	380.7	68.1	448.0	5.6	356.0	76.7	432.0	4.6	333.5	86.5	420.0	3.9
10.0	422.2	60.5	482.0	7.0	393.8	67.9	461.0	5.8	368.1	76.5	444.0	4.8	344.8	86.3	431.0	4.0

YCRS0120SC

5.0	438.2	73.0	511.0	6.0	409.2	81.7	491.0	5.0	383.0	91.8	474.0	4.2	359.4	103.4	462.0	3.5
6.0	454.1	73.1	527.0	6.2	424.2	81.9	506.0	5.2	396.8	92.1	488.0	4.3	372.4	103.7	476.0	3.6
7.0	470.3	73.2	543.0	6.4	439.1	82.0	521.0	5.4	410.9	92.2	503.0	4.5	385.5	103.9	489.0	3.7
8.0	486.9	73.2	560.0	6.7	454.6	82.0	536.0	5.5	425.4	92.4	517.0	4.6	399.0	104.1	503.0	3.8
9.0	503.8	73.1	577.0	6.9	470.3	82.0	552.0	5.7	440.0	92.4	532.0	4.8	412.7	104.3	517.0	4.0
10.0	521.1	73.0	594.0	7.1	486.1	82.0	568.0	5.9	454.9	92.5	547.0	4.9	426.7	104.5	531.0	4.1

YCRS0140SC

5.0	521.7	84.3	606.0	6.2	487.5	94.6	582.0	5.2	456.5	106.4	562.0	4.3	428.6	119.8	548.0	3.6
6.0	540.6	84.7	625.0	6.4	505.0	95.0	600.0	5.3	472.9	106.9	579.0	4.4	443.9	120.5	564.0	3.7
7.0	560.0	85.1	645.0	6.6	522.9	95.4	618.0	5.5	489.6	107.4	597.0	4.6	459.7	121.2	580.0	3.8
8.0	579.7	85.3	665.0	6.8	541.4	95.7	637.0	5.7	506.8	107.9	614.0	4.7	475.7	121.7	597.0	3.9
9.0	599.1	85.4	684.0	7.0	559.4	95.9	655.0	5.8	524.2	108.2	632.0	4.8	492.0	122.2	614.0	4.0
10.0	620.3	85.5	705.0	7.3	579.2	96.1	675.0	6.0	542.0	108.5	650.0	5.0	508.5	122.7	631.0	4.2

YCRS0180SC

5.0	628.8	96.8	725.0	6.5	586.2	108.5	694.0	5.4	549.3	122.1	671.0	4.5	514.6	137.6	652.0	3.7
6.0	651.9	97.2	749.0	6.7	607.8	108.9	716.0	5.6	568.8	122.7	691.0	4.6	533.1	138.3	671.0	3.9
7.0	675.4	97.4	772.0	6.9	630.0	109.3	739.0	5.8	589.0	123.2	712.0	4.8	552.3	139.0	691.0	4.0
8.0	699.4	97.6	797.0	7.2	652.3	109.6	762.0	6.0	609.9	123.6	733.0	4.9	571.2	139.6	710.0	4.1
9.0	724.0	97.7	821.0	7.4	675.2	109.8	785.0	6.2	631.1	123.9	755.0	5.1	591.6	140.1	731.0	4.2
10.0	747.4	97.6	845.0	7.7	698.4	109.9	808.0	6.4	652.7	124.2	776.0	5.3	611.8	140.5	752.0	4.4

NOTES:

1. KW_o = Unit kW Cooling Capacity Output
2. KW_i = Compressor kW Input
3. COP = Coefficient of Performance
4. LCWT = Leaving Chilled Water Temperature
5. Ratings based on 0.047 l/s cooler water per kW.

LCWT (°C)	SATURATED DISCHARGE TEMPERATURE (°C)															
	30.0				35.0				40.0				45.0			
	KW _o	KW _i	KW	COP	KW _o	KW _i	KW	COP	KW _o	KW _i	KW	COP	KW _o	KW _i	KW	COP

YCRS0200SC

5.0	715.2	108.8	824.0	6.6	667.6	122.0	789.0	5.5	624.4	137.2	761.0	4.6	585.6	154.6	740.0	3.8
6.0	741.3	109.2	850.0	6.8	691.9	122.5	814.0	5.7	647.1	137.9	785.0	4.7	606.9	155.5	762.0	3.9
7.0	767.9	109.5	877.0	7.0	716.6	122.9	839.0	5.8	670.4	138.5	808.0	4.8	628.6	156.2	784.0	4.0
8.0	795.1	109.7	904.0	7.3	742.0	123.2	865.0	6.0	694.0	138.9	833.0	5.0	650.8	156.9	807.0	4.2
9.0	822.9	109.8	932.0	7.5	767.9	123.4	891.0	6.2	718.1	139.3	857.0	5.2	673.3	157.5	830.0	4.3
10.0	851.2	109.8	961.0	7.8	794.2	123.5	917.0	6.4	742.5	139.6	882.0	5.3	696.3	158.0	854.0	4.4

YCRS0220SC

5.0	778.3	119.7	898.0	6.5	728.3	134.2	862.0	5.4	681.4	151.0	832.0	4.5	638.9	170.2	809.0	3.8
6.0	809.0	120.2	929.0	6.7	754.9	134.8	889.0	5.6	706.1	151.8	857.0	4.7	662.3	171.1	833.0	3.9
7.0	838.1	120.5	958.0	7.0	782.1	135.2	917.0	5.8	731.4	152.4	883.0	4.8	685.1	171.9	857.0	4.0
8.0	867.9	120.8	988.0	7.2	807.8	135.6	943.0	6.0	757.2	152.9	910.0	5.0	710.1	172.7	882.0	4.1
9.0	898.1	120.9	1019.0	7.4	838.0	135.8	973.0	6.2	783.6	153.3	937.0	5.1	734.7	173.3	908.0	4.2
10.0	929.0	120.8	1049.0	7.7	866.8	136.0	1002.0	6.4	810.4	153.6	964.0	5.3	759.8	173.9	933.0	4.4

YCRS0240SC

5.0	869.4	131.1	1000.0	6.6	787.7	146.4	934.0	5.4	737.1	164.8	902.0	4.5	691.4	185.7	877.0	3.7
6.0	872.9	131.1	1004.0	6.7	816.3	147.1	963.0	5.6	763.8	165.6	929.0	4.6	716.5	186.7	903.0	3.8
7.0	905.8	131.5	1037.0	6.9	845.6	147.6	993.0	5.7	791.1	166.3	957.0	4.8	742.1	187.6	929.0	4.0
8.0	937.9	131.8	1069.0	7.1	875.4	148.0	1023.0	5.9	818.9	166.8	985.0	4.9	768.2	188.4	956.0	4.1
9.0	970.5	131.9	1102.0	7.4	920.8	148.3	1069.0	6.2	847.3	167.3	1014.0	5.1	794.7	189.1	983.0	4.2
10.0	1004.0	131.9	1136.0	7.6	936.9	148.4	1085.0	6.3	876.2	167.6	1044.0	5.2	821.8	189.7	1011.0	4.3

NOTES:

1. KW_o = Unit kW Cooling Capacity Output
2. KW_i = Compressor kW Input
3. COP = Coefficient of Performance
4. LCWT = Leaving Chilled Water Temperature
5. Ratings based on 0.047 l/s cooler water per kW.

Part Load Ratings

English

YCRS0100SC			
Load	Tons	kW	EER
100%	81.4	101.6	9.6
75%	61.0	67.6	10.8
50%	40.7	29.2	16.7
25%	20.3	18.6	13.1
IPLV=13.7			

YCRS0200SC			
Load	Tons	kW	EER
100%	164.4	183.3	10.8
75%	123.3	121.6	12.2
50%	82.2	51.9	19.0
25%	41.1	33.0	14.9
IPLV=15.6			

YCRS0120SC			
Load	Tons	kW	EER
100%	100.7	121.8	9.9
75%	75.5	80.9	11.2
50%	50.4	37.4	16.2
25%	25.2	25.0	12.1
IPLV=13.5			

YCRS0220SC			
Load	Tons	kW	EER
100%	179.4	201.7	10.7
75%	134.6	133.9	12.1
50%	89.7	60.3	17.9
25%	44.9	39.2	13.7
IPLV=14.9			

YCRS0140SC			
Load	Tons	kW	EER
100%	120.2	142.0	10.2
75%	90.1	94.2	11.5
50%	60.1	40.2	17.9
25%	30.0	25.7	14.1
IPLV=14.7			

YCRS0240SC			
Load	Tons	kW	EER
100%	193.9	220.0	10.6
75%	145.5	146.1	12.0
50%	97.0	62.4	18.7
25%	48.5	39.7	14.7
IPLV=15.3			

YCRS0180SC			
Load	Tons	kW	EER
100%	144.5	163.1	10.6
75%	108.3	108.3	12.0
50%	72.2	49.2	17.6
25%	36.1	32.4	13.4
IPLV=14.7			

Rated in accordance with ARI Standard 550/590

SI

YCRS0100SC			
Load	kWo	kWi	COP
100%	286.1	101.6	2.8
75%	214.6	67.6	3.2
50%	143.1	29.2	4.9
25%	71.5	18.6	3.8
COP = 4.0			

YCRS0200SC			
Load	kWo	kWi	COP
100%	578.0	183.3	3.2
75%	433.5	121.6	3.6
50%	289.0	51.9	5.6
25%	144.5	33.0	4.4
COP = 4.6			

YCRS0120SC			
Load	kWo	kWi	COP
100%	354.3	121.8	2.9
75%	265.7	80.9	3.3
50%	177.1	37.4	4.7
25%	88.6	25.0	3.5
COP = 4.0			

YCRS0220SC			
Load	kWo	kWi	COP
100%	631.0	201.7	3.1
75%	473.3	133.9	3.5
50%	315.5	60.3	5.2
25%	157.8	39.2	4.0
COP = 4.4			

YCRS0140SC			
Load	kWo	kWi	COP
100%	422.7	142.0	3.0
75%	317.0	94.2	3.4
50%	211.4	40.2	5.3
25%	105.7	25.7	4.1
COP = 4.3			

YCRS0240SC			
Load	kWo	kWi	COP
100%	682.1	220.0	3.1
75%	511.6	146.1	3.5
50%	341.1	62.4	5.5
25%	170.5	39.7	4.3
COP = 4.5			

YCRS0180SC			
Load	kWo	kWi	COP
100%	508.1	163.1	3.1
75%	381.0	108.3	3.5
50%	254.0	49.2	5.2
25%	127.0	32.4	3.9
COP = 4.3			

Rated in accordance with ARI Standard 550/590

Physical Data

English

MODEL YCRS	0100SC	0120SC	0140SC	0180SC	0200SC	0220SC	0240SC
General Unit Data							
Nominal Unit Capacity (Tons)	81	101	120	145	164	179	194
Number of Independent Refrigerant Circuits	2	2	2	2	2	2	2
Nitrogen (N ₂) Shipping Charge, Ckt 1/Ckt. 2 (lbs.)	-	-	-	-	-	-	-
Oil Charge, Ckt. 1/Ckt. 2, (gal.)	2/2	2/3	3/3	3/3	3/3	3/3	3/3
Shipping Weight (lbs.)	5989	6271	6584	9026	9132	9162	9252
Operating Weight (lbs.)	6550	6852	7126	10124	10222	10232	10344
Compressors, Semi-Hermetic Twin Screw							
Quantity per Chiller	2	2	2	2	2	2	2
Nominal Size, Ckt. 1/ Ckt. 2	F/F	F/C	C/C	C/A	A/A	A/B	B/B
Evaporator, Direct Expansion - Code							
	O	O	O	P	P	Q	Q
Water Volume (gals.)	64	64	64	94	94	107	107
Maximum Water Side Pressure (psig)	150	150	150	150	150	150	150
Maximum Refrigerant Side Pressure (psig)	300	300	300	300	300	300	300
Dia. X Length, inches	19-1/2x 108	19-1/2x 108	19-1/2 x 108	21-1/4 x 156	21-1/4x 156	21-1/4x 156	21-1/4 x 156
Water Nozzle Connection Size, (inches)	8	8	8	8	8	8	8

SI

MODEL YCRS	0100SC	0120SC	0140SC	0180SC	0200SC	0220SC	0240SC
General Unit Data							
Nominal Unit Capacity (kW)	286	354	423	508	578	631	682
Number of Independent Refrigerant Circuits	3	3	3	5	5	5	5
Nitrogen (N ₂) Shipping Charge, Ckt 1/Ckt. (kgs.)	-	-	-	-	-	-	-
Oil Charge, Ckt. 1/Ckt. 2, (l)	7.6 / 7.6	7.6 / 11.4	11.4 / 11.4	11.4 / 11.4	11.4 / 11.4	11.4 / 11.4	11.4 / 11.4
Shipping Weight (kg.)	2716	2845	2986	4049	4142	4156	4197
Operating Weight (kg.)	2971	3108	3249	4592	4637	4641	4692
Compressors, Semi-Hermetic Twin Screw							
Quantity per Chiller	2	2	2	2	2	2	2
Nominal Size, Ckt. 1/ Ckt. 2	F/F	F/C	C/C	C/A	A/A	A/B	B/B
Evaporator, Direct Expansion - Code							
	O	O	O	P	P	Q	Q
Water Volume (l/s)	242	242	242	357	357	406	406
Maximum Water Side Pressure (barg)	10.0	10.0	10.0	10.0	10.0	10.0	10.0
Maximum Refrigerant Side Pressure (barg)	22.7	22.7	22.7	22.7	22.7	22.7	22.7
Dia. X Length, mm	495 x 2743	495 x 2743	495 x 2743	540 x 3963	540 x 3963	540 x 3963	540 x 3963
Water Nozzle Connection Size, (inches)	8	8	8	8	8	8	8

Isolator Selection Data

Weight Distribution by Model English

Model	A	B	C	D	Oper. Weight (lbs)
YCRS0100SC	1595	1595	1680	1680	6550
YCRS0120SC	1699	1699	1727	1727	6852
YCRS0140SC	1798	1798	1783	1783	7162
YCRS0180SC	2531	2531	2531	2531	10124
YCRS0200SC	2548	2548	2563	2563	10222
YCRS0220SC	2543	2543	2573	2573	10232
YCRS0240SC	2566	2566	2606	2606	10344

Weight Distribution by Model SI

Model	A	B	C	D	Oper. Weight (kg)
YCRS0100SC	723	723	762	762	2971
YCRS0120SC	771	771	783	783	3108
YCRS0140SC	816	816	809	809	3249
YCRS0180SC	1148	1148	1148	1148	4592
YCRS0200SC	1156	1156	1163	1163	4637
YCRS0220SC	1154	1154	1167	1167	4641
YCRS0240SC	1164	1164	1182	1182	4692

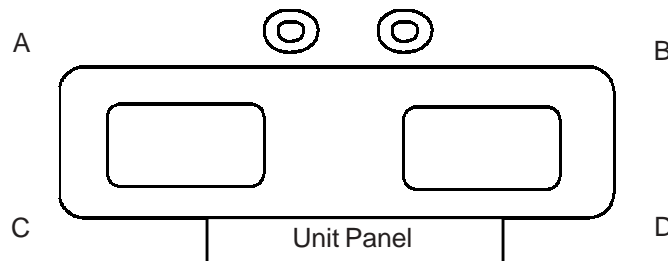

Sesmic Isolator AWMR-2- Selections

Model	A	B	C	D
YCRS0100SC	53	53	53	53
YCRS0120SC	53	53	53	53
YCRS0140SC	53	53	53	53
YCRS0180SC	532	532	532	532
YCRS0200SC	532	532	532	532
YCRS0220SC	532	532	532	532
YCRS0240SC	532	532	532	532

1" Isolator Selections - VMC Type CP-2- X

Model	A	B	C	D
YCRS0100SC	28	28	28	28
YCRS0120SC	31	31	31	31
YCRS0140SC	31	31	31	31
YCRS0180SC	35	35	35	35
YCRS0200SC	35	35	35	35
YCRS0220SC	35	35	35	35
YCRS0240SC	35	35	35	35

Neoprene -VMC Type RD-4 Selections

Model	A	B	C	D
YCRS0100SC	RED	RED	RED	RED
YCRS0120SC	RED	RED	RED	RED
YCRS0140SC	RED	RED	RED	RED
YCRS0180SC	GREEN	GREEN	GREEN	GREEN
YCRS0200SC	GREEN	GREEN	GREEN	GREEN
YCRS0220SC	GREEN	GREEN	GREEN	GREEN
YCRS0240SC	GREEN	GREEN	GREEN	GREEN

Isolator Details

1" ISOLATOR DETAILS

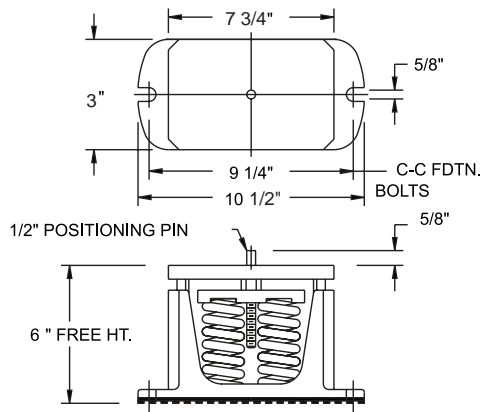

ENGLISH

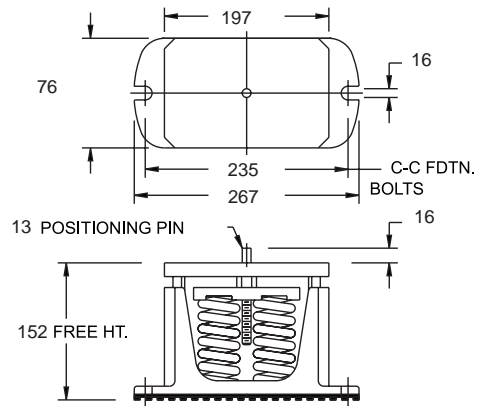

SI

TYPE & SIZE	MAX LOAD		DEFL.		SPRING COLOR
	lbs.	kg	in.	mm	
CP-2-28	1800	816	1.0	26	Green
CP-2-31	2200	998	0.83	21.0	Gray
CP-2-35	3000	1360	0.7	17.7	Gold

ISOLATOR MOUNTING BRACKET

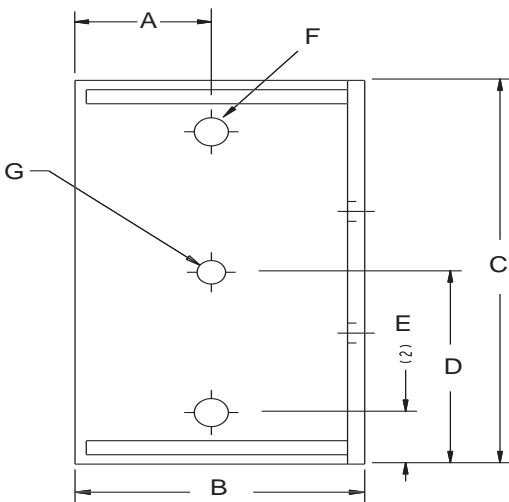

ISOLATOR BRACKET DIMENSIONS

Item	A	B	C	D
Eng	3	6 3/8	10 1/4	5 1/8
SI	76	162	260	130

Item	E	F	G
Eng	1 3/8	3/4	5/16
SI	35	19	8

NEOPRENE ISOLATOR DETAILS

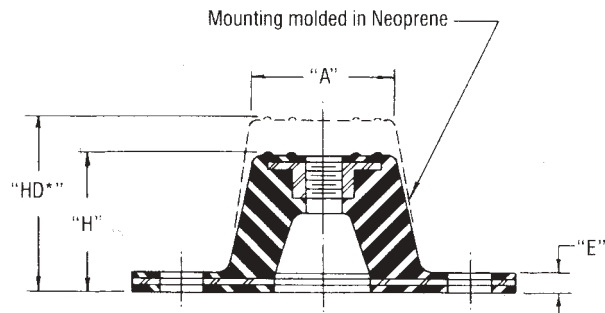
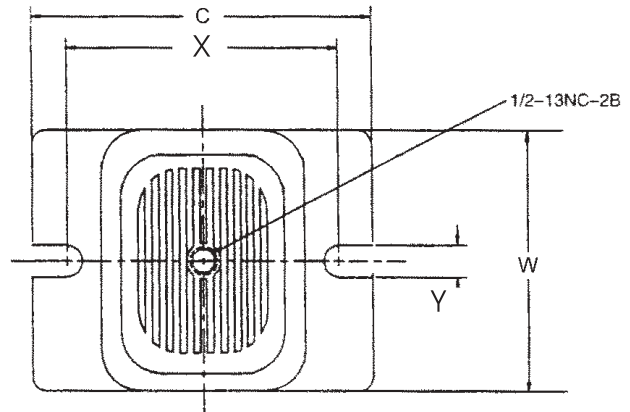

TYPE	A	C	E	H	HD	W	X	Y
R-4 or RD-4	3"	6.250"	0.4"	1.625"	2.75"	4.625"	5"	0.55"
	76mm	159mm	10mm	41mm	70mm	118mm	127mm	14mm

SEISMIC ISOLATOR DETAILS

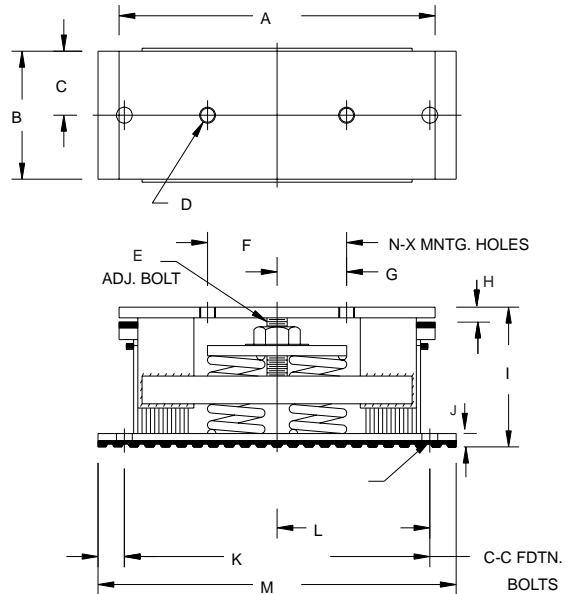

SEISMIC ISOLATORS

TYPE & SIZE	MAX LOAD		DEFL.	
	kg	lbs.	mm	in
AWMR-2-53	907	2000	51	2
AWMR-2-532	1361	3000	51	2

AWMR DIMENSIONS

	A	B	C	D	E	F	G	H	I	J	K	L	M	N/X
AWMR-2 50-5XX	381mm	152mm	76mm	19 10NC	19mm	191mm	95mm	13mm	241mm	17mm	368mm	184mm	432mm	19mm 16mm

	A	B	C	D	E	F	G	H	I	J	K	L	M	N/X
AWMR-2 50-5XX	15"	6"	3"	3/4 10NC	1"	7 - 1/2"	3-3/4"	1/2"	9 1/2"	5/8"	14.5"	7-1/4"	17"	3/4" 5/8"

Sound Data

Sound Pressure Levels (SPL), dB re 20 microPa in accordance with ARI Standard 575-94

MODEL	Octave Band Hz									Weighted dBA
	63	125	250	500	1000	2000	4000	8000		
YCRS0100SC	76	72	71.5	76	75	73	64	62	79	
YCRS0120SC	76	72	72	77	76	73	64	62	80	
YCRS0140SC	76	72	72.5	78	77	74	65	62	81	
YCRS0180SC	76	73	73	79	78.5	75	65	62	82	
YCRS0200SC	76	73	73.5	80	79.5	76	66	62	83	
YCRS0220SC	76	74	74	81	80.5	77	66.5	62	84	
YCRS0240SC	76	74	75	82	81.5	78	67	62	85	

Note: All 'A' weighted sound pressure data ± 3 dBA

Dimensions (English)

Mounting Dimensions

Model	AA	BB	CC
YCRS0100SC	115-5/8	34	23-3/4
YCRS0120SC	115-5/8	34	23-3/4
YCRS0140SC	115-5/8	34	23-3/4
YCRS0180SC	162-7/8	36	25-3/4
YCRS0200SC	162-7/8	36	25-3/4
YCRS0220SC	162-7/8	36	25-3/4
YCRS0240SC	162-7/8	36	25-3/4

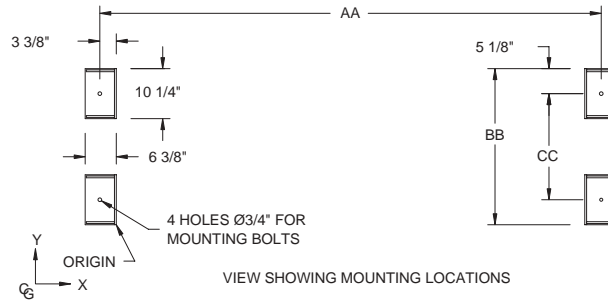

Center of gravity (inches)

Model	X	Y	Z
YCRS0100SC	57	21	39
YCRS0120SC	58	22	39
YCRS0140SC	57	22	39
YCRS0180SC	80	24	43
YCRS0200SC	80	24	43
YCRS0220SC	80	24	43
YCRS0240SC	80	24	43

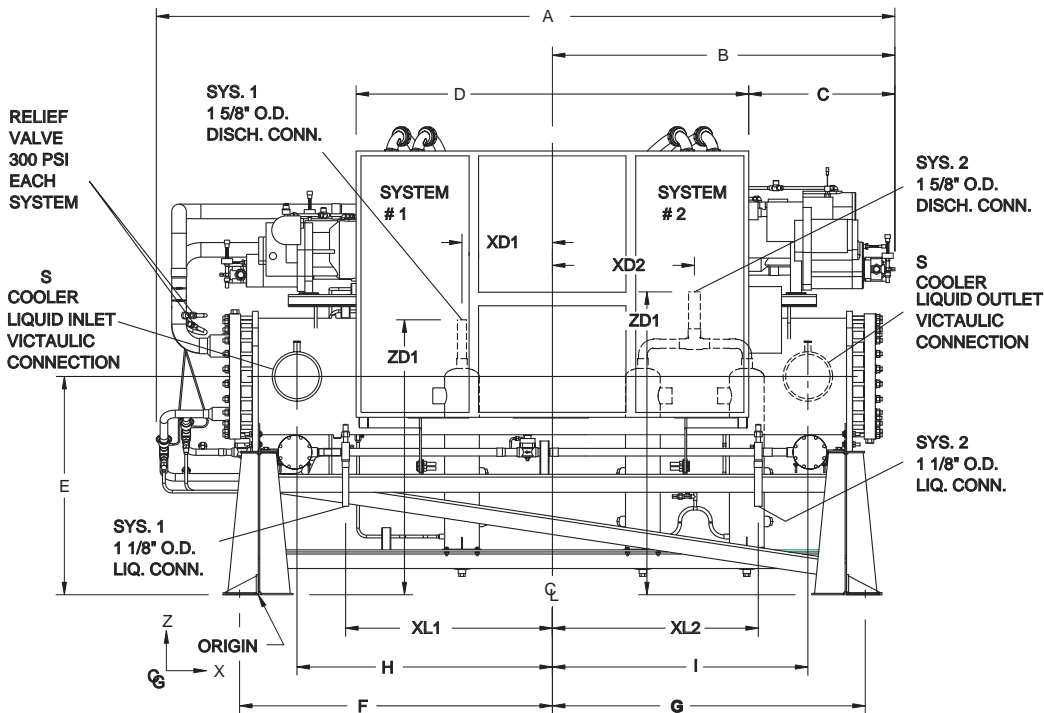
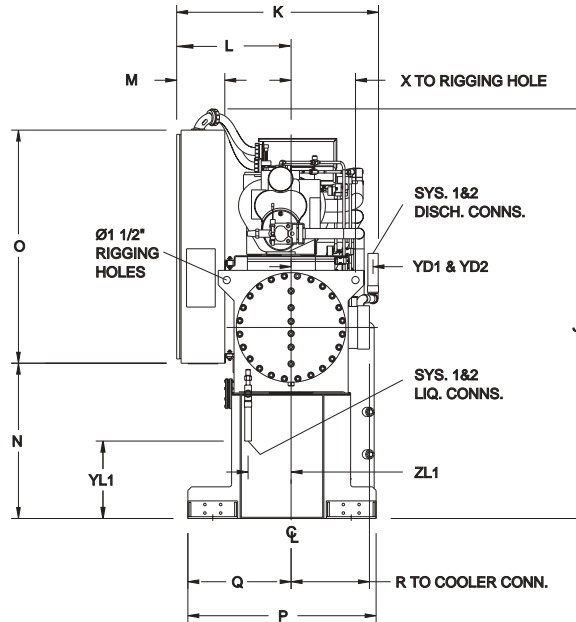

DIMENSIONS

REF	YCRS0100	YCRS0120	YCRS0140	YCRS0180	YCRS0200	YCRS0220	YCRS0240
A	131-5/16"	139-3/32"	139-3/32"	177-3/4"	177-3/4"	177-3/4"	177-3/4"
B	59-15/16"	61-3/4"	61-3/4"	83-3/8"	83-3/8"	83-3/8"	83-3/8"
C	29-15/16"	31-3/8"	31-3/8"	53"	53"	53"	53"
D	60"	60"	60"	60"	60"	60"	60"
E	33-3/8"	33-3/8"	33-3/8"	39-9/32"	39-9/32"	39-9/32"	39-9/32"
F	56-3/8"	56-3/8"	56-3/8"	80-5/16"	80-5/16"	80-5/16"	80-5/16"
G	56-3/8"	56-3/8"	56-3/8"	80-5/16"	80-5/16"	80-5/16"	80-5/16"
H	46-1/32"	46-1/32"	46-1/32"	67-25/32"	67-25/32"	67-25/32"	67-25/32"
I	46-1/32"	46-1/32"	46-1/32"	67-25/32"	67-25/32"	67-25/32"	67-25/32"
J	78-1/4"	78-1/4"	78-1/4"	78-27/32"	78-27/32"	78-27/32"	78-27/32"
K	38-3/8"	40-7/16"	40-7/16"	42-5/16"	42-5/16"	42-5/16"	42-5/16"
L	23-21/32"	23-21/32"	23-21/32"	23-3/4"	23-3/4"	23-3/4"	23-3/4"
M	10"	10"	10"	10"	10"	10"	10"
N	32"	32"	32"	32"	32"	32"	32"
O	40-7/8"	40-7/8"	40-7/8"	40-7/8"	40-7/8"	40-7/8"	40-7/8"
P	38-3/4"	38-3/4"	38-3/4"	38-3/4"	38-3/4"	38-3/4"	38-3/4"
Q	21-1/4"	21-1/4"	21-1/4"	21-1/4"	21-1/4"	21-1/4"	21-1/4"
R	17-1/2"	17-1/2"	17-1/2"	17-1/2"	17-1/2"	17-1/2"	17-1/2"
S	8"	8"	8"	8"	8"	8"	8"
T	13-1/4"	13-1/4"	13-1/4"	14-21/32"	14-21/32"	14-21/32"	14-21/32"
XL1	37- 1/4"	37-1/4"	37-1/4"	61-1/16"	61-1/16"	61-1/16"	61-1/16"
XL2	37-9/32"	37-9/32"	37-9/32"	61-1/8"	61-1/8"	61-1/8"	61-1/8"
YLI	15-15/16"	15-15/16"	15-15/16"	15-1/2"	15-1/2"	15-1/2"	15-1/2"
ZL1	10-3/16"	10-3/16"	10-3/16"	10-3/4"	10-3/4"	10-3/4"	10-3/4"
XD1	16-15/16"	16-15/16"	16-15/16"	16-15/16"	16-15/16"	16-15/16"	16-15/16"
XD2	16-5/16"	16-5/16"	16-5/16"	16-5/16"	16-5/16"	16-5/16"	16-5/16"
YD1	13-7/8"	13-7/8"	10-9/16"	17-1/2"	17-1/2"	17-1/2"	17-1/2"
YD2	13-7/8"	10-9/16"	10-9/16"	17-1/2"	17-1/2"	17-1/2"	17-1/2"
ZD1	49-1/4"	49-1/4"	54-7/8"	51-13/16"	51-13/16"	51-13/16"	51-13/16"
ZD2	49 - 1/4	54-7/8"	54-7/8"	51-13/16"	51-13/16"	51-13/16"	51-13/16"

REVISED DIMENSIONS FOR 200/230V CHILLERS

REF	YCRS0100	YCRS0120	YCRS0140	YCRS0180	YCRS0200	YCRS0220	YCRS0240
C	32-1/4"	32-1/4"	32-1/4"	56"	56"	56"	56"
D	70-1/2"	70-1/2"	70-1/2"	70-1/2"	70-1/2"	70-1/2"	70-1/2"
Q	20-7/8"	20-7/8"	20-7/8"	25-15/16"	25-15/16"	25-15/16"	25-15/16"
R	48"	48"	48"	48"	48"	48"	48"

NOTES:

- CLEARANCES - Recommended YORK clearances to service the unit are as follows:
 Rear to Wall: 1' 8"
 Front to Wall: 2' 8"
 Top: 1' 8"
 Tube removal 100, 120, 140: 9' (either end)
 180,200, 220, 240: 13' (either end)
- Shipping skids (not shown) will increase the height of the unit by 6", but **MUST** be removed upon installation.
- Spring and neoprene isolators will increase the overall height of the unit by approximately 3".
- Sismic isolators will increase the height of the unit by approximately 9- 1/2".
- To install spring 1" isolators, the bracket/feet must be flipped over so that the isolator fits within the bracket.

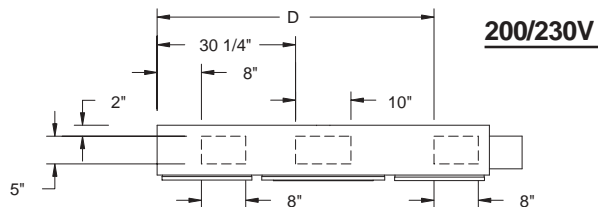

VIEW SHOWING CUSTOMER POWER ENTRY LOCATIONS ON UNDERSIDE OF PANEL

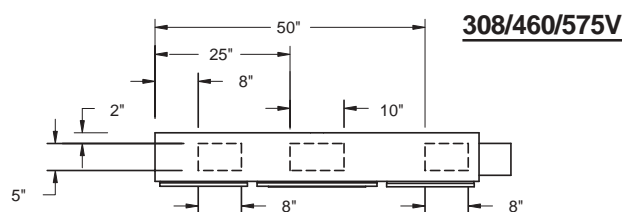

VIEW SHOWING CUSTOMER POWER ENTRY LOCATIONS ON UNDERSIDE OF PANEL

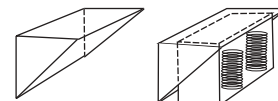

Dimensions (SI)

Mounting Dimensions (mm)

Model	AA	BB	CC
YCRS0100SC	2937	864	603
YCRS0120SC	2937	864	603
YCRS0140SC	2937	864	603
YCRS0180SC	4137	914	654
YCRS0200SC	4137	914	654
YCRS0220SC	4137	914	654
YCRS0240SC	4137	914	654

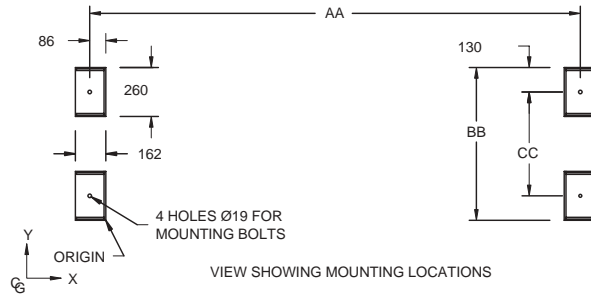

Center of gravity (mm)

Model	X	Y	Z
YCRS0100SC	1443	543	991
YCRS0120SC	1470	550	991
YCRS0140SC	1443	554	991
YCRS0180SC	2032	613	1092
YCRS0200SC	2025	612	1092
YCRS0220SC	2035	610	1092
YCRS0240SC	2029	609	1092

All dimensions are in mm unless otherwise noted.

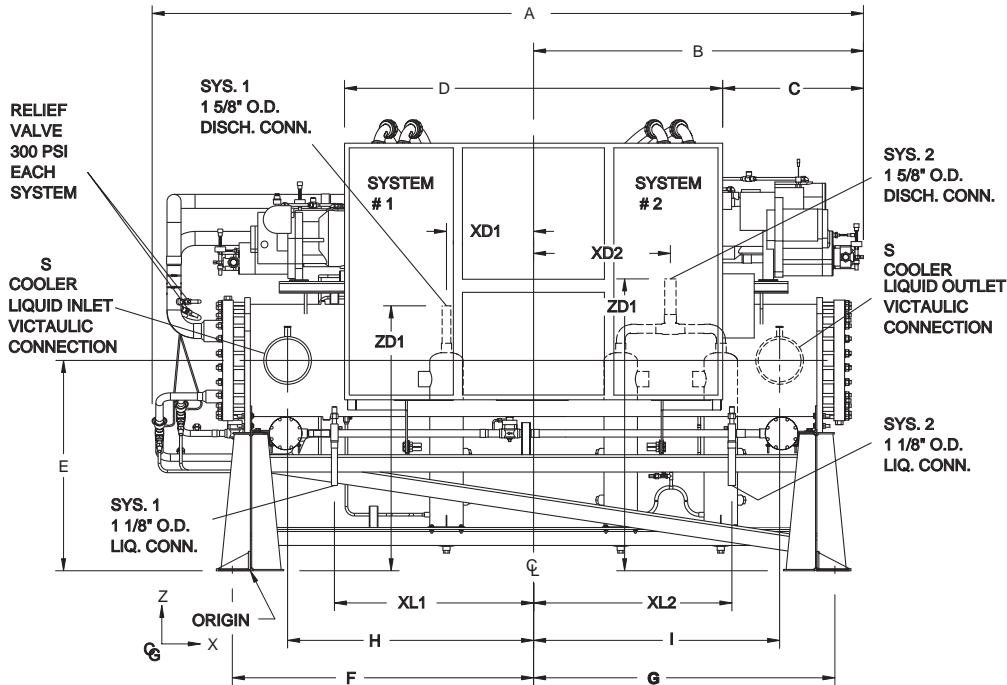
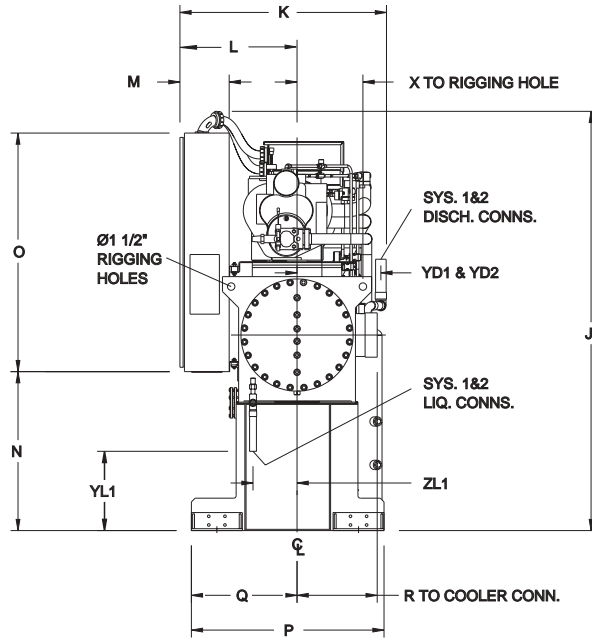

REF NO	YCRS0100	YCRS0120	YCRS0140	YCRS0180	YCRS0200	YCRS0220	YCRS0240
A	3335	3533	3533	4515	4515	4515	4515
B	1522	1568	1568	2118	2118	2118	2118
C	760	797	797	1346	1346	1346	1346
D	1524	1524	1524	1524	1524	1524	1524
E	848	848	848	998	998	998	998
F	1432	1432	1432	2040	2040	2040	2040
G	1432	1432	1432	2040	2040	2040	2040
H	1169	1169	1169	1722	1722	1722	1722
I	1169	1169	1169	1722	1722	1722	1722
J	1988	1988	1988	2003	2003	2003	2003
K	975	1027	1027	1075	1075	1075	1075
L	601	601	601	603	603	603	603
M	254	254	254	254	254	254	254
N	813	813	813	813	813	813	813
O	1038	1038	1038	1038	1038	1038	1038
P	984	984	984	984	984	984	984
Q	540	540	540	540	540	540	540
R	445	445	445	445	445	445	445
S	203	203	203	203	203	203	203
T	337	337	337	372	372	372	372
XL1	946	946	946	1551	1551	1551	1551
XL2	947	947	947	1553	1553	1553	1553
YLI	405	405	405	394	394	394	394
ZL1	259	259	259	273	273	273	273
XD1	430	430	430	430	430	430	430
XD2	414	414	414	414	414	414	414
YD1	352	352	268	445	445	445	445
ZD1	352	268	268	445	445	445	445

REVISED DIMENSIONS FOR 200/230V CHILLERS

REF	YCRS0100	YCRS0120	YCRS0140	YCRS0180	YCRS0200	YCRS0220	YCRS0240
C	819	819	819	1422	1422	1422	1422
D	1791	1791	1791	1791	1791	1791	1791
Q	530	530	530	659	659	659	659
R	1219	1219	1219	1219	1219	1219	1219

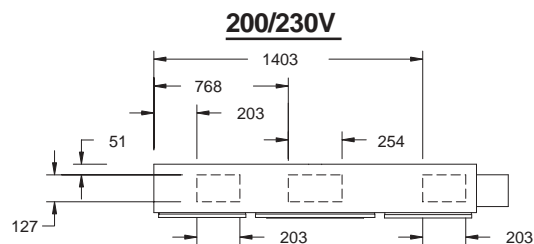

VIEW SHOWING CUSTOMER POWER ENTRY LOCATIONS ON UNDERSIDE OF PANEL

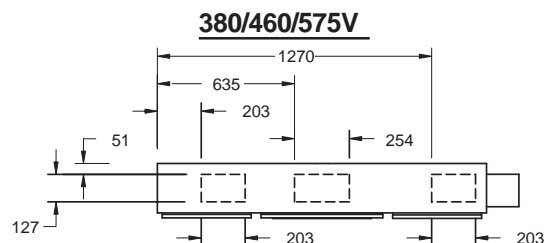

VIEW SHOWING CUSTOMER POWER ENTRY LOCATIONS ON UNDERSIDE OF PANEL

NOTES:

- CLEARANCES - Recommended YORK clearances to service the unit are as follows:
 Rear to Wall: 508mm
 Front to Wall: 813mm
 Top: 508mm
 Tube removal 100, 120, 140: 2743mm (either end)
 180, 200, 220, 240: 3962mm (either end)
- Shipping skids (not shown) will increase the height of the unit by 152mm, but **MUST** be removed upon installation.
- Spring and neoprene isolators will increase the overall height of the unit by approximately 76mm.
- Sismic isolators will increase the height of the unit by approximately 241mm.
- To install spring 1" isolators, the bracket/feet must be flipped over so that the isolator fits within the bracket.

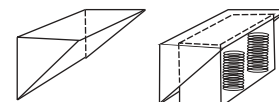

Electrical Data (Multi-Point Wiring)

MULTIPOINT POWER SUPPLY (SEE FIG 9 , PAGE 36)

(Each of the two field provided power supply circuits individually protected with branch circuit protection. Field connections to factory provided Terminal Block(std), Non-Fused Disconnects(opt) or individual system Circuit Breakers(opt) in each of the two motor control centers.)

SYSTEM #1							
CHILLER MODEL	VOLT CODE HZ	MIN ⁽¹⁾ CIR. MCA	MIN NF DISC SW	MIN DUAL FUSE	MAX DUAL FUSE MAX CB	RLA	Y-D LRA
YCRS0100SC	200	215	200	300	350	172	404
	230	187	200	225	300	149	354
	380	113	150	150	200	90	219
	460	94	100	125	150	75	174
	575	75	100	100	125	60	138
YCRS0120SC	200	215	200	300	350	172	404
	230	187	200	225	300	149	354
	380	113	150	150	200	90	219
	460	94	100	125	150	75	174
	575	75	100	100	125	60	138
YCRS0140SC	200	289	400	350	500	231	591
	230	252	250	350	450	201	481
	380	153	150	200	250	122	285
	460	127	150	175	225	101	228
	575	102	100	125	175	81	182
YCRS0180SC	200	292	400	350	500	233	591
	230	254	250	350	450	203	481
	380	154	150	200	250	123	285
	460	127	150	175	225	101	228
	575	102	100	125	175	81	182
YCRS0200SC	200	370	400	450	600	296	708
	230	323	400	400	500	258	642
	380	195	200	250	350	156	343
	460	162	150	200	250	129	280
	575	129	150	175	225	103	224
YCRS0220SC	200	370	400	450	600	296	708
	230	323	400	400	500	258	642
	380	195	200	250	350	156	343
	460	162	150	200	250	129	280
	575	129	150	175	225	103	224
YCRS0240SC	200	447	600	600	800	357	708
	230	388	400	500	600	310	642
	380	235	250	300	400	188	343
	460	194	200	250	300	155	280
	575	155	150	200	250	124	224

SYSTEM #2							
CHILLER MODEL	VOLT CODE HZ	MIN ⁽¹⁾ CIR. MCA	MIN NF DISC SW	MIN DUAL FUSE	MAX DUAL FUSE MAX CB	RLA	Y-D LRA
YCRS0100SC	200	215	200	300	350	172	404
	230	187	200	225	300	149	354
	380	113	150	150	200	90	219
	460	94	100	125	150	75	174
	575	75	100	100	125	60	138
YCRS0120SC	200	289	400	350	500	231	591
	230	252	250	350	450	201	481
	380	153	150	200	250	122	285
	460	127	150	175	225	101	228
	575	102	100	125	175	81	182
YCRS0140SC	200	289	400	350	500	231	591
	230	252	250	350	450	201	481
	380	153	150	200	250	122	285
	460	127	150	175	225	101	228
	575	102	100	125	175	81	182
YCRS0180SC	200	370	400	450	600	296	708
	230	323	400	400	500	258	642
	380	195	200	250	350	156	343
	460	162	150	200	250	129	280
	575	129	150	175	225	103	224
YCRS0200SC	200	370	400	450	600	296	708
	230	323	400	400	500	258	642
	380	195	200	250	350	156	343
	460	162	150	200	250	129	280
	575	129	150	175	225	103	224
YCRS0220SC	200	447	600	600	800	357	708
	230	388	400	500	600	310	642
	380	235	250	300	400	188	343
	460	194	200	250	300	155	280
	575	155	150	200	250	124	224
YCRS0240SC	200	447	600	600	800	357	708
	230	388	400	500	600	310	642
	380	235	250	300	400	188	343
	460	194	200	250	300	155	280
	575	155	150	200	250	124	224

Incoming Wire Range (Multi-point)

MULTIPOINT WIRING SYSTEM #1

CHILLER MODEL	VOLT CODE	TERM BLK	TERMINAL BLK CUSTOMER GROUND	N-F DIS SW	N-F DIS SW CUSTOMER GROUND	CKT.BRKR	CKT.BRKR CUSTOMER GROUND
YCRS0100SC	-17	#2 - 4/0 AWG	# 8 - 2 AWG	#4 - 300 KCM	# 6 - 1/0 AWG	#6 - 350 KCM	# 6 - 1/0 AWG
YCRS0120SC		#2 - 4/0 AWG	# 8 - 2 AWG	#4 - 300 KCM	# 6 - 1/0 AWG	#4 - 300 KCM	# 6 - 1/0 AWG
YCRS0140SC		#2/0 - 500 KCM	# 4 - 3/0 AWG	#6 - 350 KCM	# 6 - 1/0 AWG	250 - 500 KCM	# 4 - 3/0 AWG
YCRS0180SC		#2/0 - 500 KCM	# 4 - 3/0 AWG	#4 - 300 KCM	# 6 - 1/0 AWG	250 - 500 KCM	# 4 - 3/0 AWG
YCRS0200SC		#2/0 - 500 KCM	# 4 - 3/0 AWG	# 8 - 350 KCM	# 4 - 3/0 AWG	250 - 500 KCM	# 4 - 3/0 AWG
YCRS0220SC		#2/0 - 500 KCM	# 4 - 3/0 AWG	250 - 500 KCM	# 4 - 3/0 AWG	250 - 500 KCM	# 4 - 3/0 AWG
YCRS0240SC		(2) #2 - 4/0 AWG	(2) # 6 - 1/0 AWG	(2) #3/0 - 250 KCM	# 4 - 3/0 AWG	(3) 2/0 - 400 KCM	(2) # 2 - 4/0 AWG
YCRS0100SC	-28	#2 - 4/0 AWG	# 8 - 2 AWG	#4 - 300 KCM	# 6 - 1/0 AWG	#4 - 300 KCM	# 6 - 1/0 AWG
YCRS0120SC		#2 - 4/0 AWG	# 8 - 2 AWG	#4 - 300 KCM	# 8 - 2 AWG	#4 - 300 KCM	# 6 - 1/0 AWG
YCRS0140SC		#2 - 300 KCM	# 6 - 1/0 AWG	#4 - 300 KCM	# 6 - 1/0 AWG	#4 - 300 KCM	# 4 - 3/0 AWG
YCRS0180SC		#2 - 300 KCM	# 6 - 1/0 AWG	#4 - 300 KCM	# 6 - 1/0 AWG	250 - 500 KCM	# 4 - 3/0 AWG
YCRS0200SC		#2/0 - 500 KCM	# 4 - 3/0 AWG	#6 - 350 KCM	# 6 - 1/0 AWG	250 - 500 KCM	# 4 - 3/0 AWG
YCRS0220SC		#2/0 - 500 KCM	# 4 - 3/0 AWG	250 - 500 KCM	# 4 - 3/0 AWG	250 - 500 KCM	# 4 - 3/0 AWG
YCRS0240SC		#2/0 - 500 KCM	# 4 - 3/0 AWG	250 - 500 KCM	# 4 - 3/0 AWG	250 - 500 KCM	# 4 - 3/0 AWG
YCRS0100SC	-40	#6 - 1/0 AWG	# 8 - 2 AWG	#14 - 1/0 AWG	# 8 - 2 AWG	#4 - 300 KCM	# 8 - 2 AWG
YCRS0120SC		#6 - 1/0 AWG	# 8 - 2 AWG	#14 - 1/0 AWG	# 8 - 2 AWG	#4 - 300 KCM	# 8 - 2 AWG
YCRS0140SC		#2 - 4/0 AWG	# 8 - 2 AWG	#4 - 300 KCM	# 8 - 2 AWG	#4 - 300 KCM	# 6 - 1/0 AWG
YCRS0180SC		#2 - 4/0 AWG	# 8 - 2 AWG	#4 - 300 KCM	# 8 - 2 AWG	#4 - 300 KCM	# 6 - 1/0 AWG
YCRS0200SC		#2 - 4/0 AWG	# 8 - 2 AWG	#4 - 300 KCM	# 8 - 2 AWG	#4 - 300 KCM	# 6 - 1/0 AWG
YCRS0220SC		#2 - 4/0 AWG	# 8 - 2 AWG	#4 - 300 KCM	# 8 - 2 AWG	#4 - 300 KCM	# 6 - 1/0 AWG
YCRS0240SC		#2 - 4/0 AWG	# 8 - 2 AWG	#4 - 300 KCM	# 6 - 1/0 AWG	#6 - 350 KCM	# 6 - 1/0 AWG
YCRS0100SC	-46	#6 - 1/0 AWG	# 8 - 2 AWG	#14 - 1/0 AWG	# 8 - 2 AWG	#14 - 1/0 AWG	# 8 - 2 AWG
YCRS0120SC		#6 - 1/0 AWG	# 8 - 2 AWG	#14 - 1/0 AWG	# 8 - 2 AWG	#14 - 1/0 AWG	# 8 - 2 AWG
YCRS0140SC		#6 - 1/0 AWG	# 8 - 2 AWG	#4 - 300 KCM	# 8 - 2 AWG	#4 - 300 KCM	# 8 - 2 AWG
YCRS0180SC		#6 - 1/0 AWG	# 8 - 2 AWG	#14 - 1/0 AWG	# 8 - 2 AWG	#4 - 300 KCM	# 8 - 2 AWG
YCRS0200SC		#2 - 4/0 AWG	# 8 - 2 AWG	#4 - 300 KCM	# 8 - 2 AWG	#4 - 300 KCM	# 6 - 1/0 AWG
YCRS0220SC		#2 - 4/0 AWG	# 8 - 2 AWG	#4 - 300 KCM	# 8 - 2 AWG	#4 - 300 KCM	# 6 - 1/0 AWG
YCRS0240SC		#2 - 4/0 AWG	# 8 - 2 AWG	#4 - 300 KCM	# 8 - 2 AWG	#4 - 300 KCM	# 6 - 1/0 AWG
YCRS0100SC	-58	#18 - 2 AWG	# 8 - 2 AWG	#14 - 1/0 AWG	# 8 - 2 AWG	#14 - 1/0 AWG	# 8 - 2 AWG
YCRS0120SC		#18 - 2 AWG	# 8 - 2 AWG	#14 - 1/0 AWG	# 8 - 2 AWG	#14 - 1/0 AWG	# 8 - 2 AWG
YCRS0140SC		#6 - 1/0 AWG	# 8 - 2 AWG	#14 - 1/0 AWG	# 8 - 2 AWG	#2 - 4/0 AWG	# 8 - 2 AWG
YCRS0180SC		#6 - 1/0 AWG	# 8 - 2 AWG	#14 - 1/0 AWG	# 8 - 2 AWG	#2 - 4/0 AWG	# 8 - 2 AWG
YCRS0200SC		#6 - 1/0 AWG	# 8 - 2 AWG	#14 - 1/0 AWG	# 8 - 2 AWG	#4 - 300 KCM	# 8 - 2 AWG
YCRS0220SC		#6 - 1/0 AWG	# 8 - 2 AWG	#14 - 1/0 AWG	# 8 - 2 AWG	#4 - 300 KCM	# 8 - 2 AWG
YCRS0240SC		#2 - 4/0 AWG	# 8 - 2 AWG	#4 - 300 KCM	# 8 - 2 AWG	#4 - 300 KCM	# 8 - 2 AWG

NOTES: (for Electrical Data on pages 30-35)

1. Minimum Circuit Ampacity (MCA) is based on 125% of the rated load amps for the largest motor plus 100% of the rated load amps for all other loads included in the circuit, per N.E.C. Article 440.33. If the optional Factory Mounted Control Transformer is provided, add the following MCA values to the electrical tables for the system providing power to the transformer: -50, add 5 amps;
2. The minimum recommended disconnect switch is based on 115% of the rated load amps for all loads included in the circuit, per N.E.C. Article 440.
3. Minimum fuse size is based upon 150% of the rated load amps for the largest motor plus 100% of the rated load amps for all other loads included in the circuit to avoid nuisance trips at start-up due to lock rotor amps. It is not recommended in applications where brown outs, frequent starting and stopping of the unit, and/or operation at ambient temperatures in excess of 35°C (95°F) is anticipated.
4. Maximum fuse size is based upon 225% of the rated load amps for the largest motor plus 100% of the rated load amps for all other loads included in the circuit, per N.E.C. Article 440.22.

MULTIPOINT WIRING SYSTEM #2

CHILLER MODEL	VOLT CODE	TERM BLK	TERMINAL BLK CUSTOMER GROUND	N-F DIS SW	N-F DIS SW CUSTOMER GROUND	CKT.BRKR	CKT.BRKR CUSTOMER GROUND
YCRS0100SC	-17	#2 - 4/0 AWG	# 8 - 2 AWG	#4 - 300 KCM	# 6 - 1/0 AWG	#6 - 350 KCM	# 6 - 1/0 AWG
YCRS0120SC		#2/0 - 500 KCM	# 4 - 3/0 AWG	#6 - 350 KCM	# 6 - 1/0 AWG	250 - 500 KCM	# 4 - 3/0 AWG
YCRS0140SC		#2/0 - 500 KCM	# 4 - 3/0 AWG	#6 - 350 KCM	# 6 - 1/0 AWG	250 - 500 KCM	# 4 - 3/0 AWG
YCRS0180SC		#2/0 - 500 KCM	# 4 - 3/0 AWG	250 - 500 KCM	# 4 - 3/0 AWG	250 - 500 KCM	# 4 - 3/0 AWG
YCRS0200SC		#2/0 - 500 KCM	# 4 - 3/0 AWG	250 - 500 KCM	# 4 - 3/0 AWG	250 - 500 KCM	# 4 - 3/0 AWG
YCRS0220SC		(2) #2 - 4/0 AWG	(2) # 6 - 1/0 AWG	(2) #3/0 - 250 KCM	# 4 - 3/0 AWG	(3) 2/0 - 400 KCM	(2) # 2 - 4/0 AWG
YCRS0240SC		(2) #2 - 4/0 AWG	(2) # 6 - 1/0 AWG	(2) #3/0 - 250 KCM	# 4 - 3/0 AWG	(3) 2/0 - 400 KCM	(2) # 2 - 4/0 AWG
YCRS0100SC	-28	#2 - 4/0 AWG	# 8 - 2 AWG	#4 - 300 KCM	# 6 - 1/0 AWG	#4 - 300 KCM	# 6 - 1/0 AWG
YCRS0120SC		#2 - 300 KCM	# 6 - 1/0 AWG	#4 - 300 KCM	# 6 - 1/0 AWG	#4 - 300 KCM	# 4 - 3/0 AWG
YCRS0140SC		#2 - 300 KCM	# 6 - 1/0 AWG	#4 - 300 KCM	# 6 - 1/0 AWG	#4 - 300 KCM	# 4 - 3/0 AWG
YCRS0180SC		#2/0 - 500 KCM	# 4 - 3/0 AWG	#6 - 350 KCM	# 6 - 1/0 AWG	250 - 500 KCM	# 4 - 3/0 AWG
YCRS0200SC		#2/0 - 500 KCM	# 4 - 3/0 AWG	#6 - 350 KCM	# 6 - 1/0 AWG	250 - 500 KCM	# 4 - 3/0 AWG
YCRS0220SC		#2/0 - 500 KCM	# 4 - 3/0 AWG	250 - 500 KCM	# 4 - 3/0 AWG	250 - 500 KCM	# 4 - 3/0 AWG
YCRS0240SC		#2/0 - 500 KCM	# 4 - 3/0 AWG	250 - 500 KCM	# 4 - 3/0 AWG	250 - 500 KCM	# 4 - 3/0 AWG
YCRS0100SC	-40	#6 - 1/0 AWG	# 8 - 2 AWG	#14 - 1/0 AWG	# 8 - 2 AWG	#4 - 300 KCM	# 8 - 2 AWG
YCRS0120SC		#2 - 4/0 AWG	# 8 - 2 AWG	#4 - 300 KCM	# 8 - 2 AWG	#4 - 300 KCM	# 6 - 1/0 AWG
YCRS0140SC		#2 - 4/0 AWG	# 8 - 2 AWG	#4 - 300 KCM	# 8 - 2 AWG	#4 - 300 KCM	# 6 - 1/0 AWG
YCRS0180SC		#2 - 4/0 AWG	# 8 - 2 AWG	#4 - 300 KCM	# 8 - 2 AWG	#4 - 300 KCM	# 6 - 1/0 AWG
YCRS0200SC		#2 - 4/0 AWG	# 8 - 2 AWG	#4 - 300 KCM	# 8 - 2 AWG	#4 - 300 KCM	# 6 - 1/0 AWG
YCRS0220SC		#2 - 4/0 AWG	# 8 - 2 AWG	#4 - 300 KCM	# 6 - 1/0 AWG	#6 - 350 KCM	# 6 - 1/0 AWG
YCRS0240SC		#2 - 4/0 AWG	# 8 - 2 AWG	#4 - 300 KCM	# 6 - 1/0 AWG	#6 - 350 KCM	# 6 - 1/0 AWG
YCRS0100SC	-46	#6 - 1/0 AWG	# 8 - 2 AWG	#14 - 1/0 AWG	# 8 - 2 AWG	#14 - 1/0 AWG	# 8 - 2 AWG
YCRS0120SC		#6 - 1/0 AWG	# 8 - 2 AWG	#4 - 300 KCM	# 8 - 2 AWG	#4 - 300 KCM	# 8 - 2 AWG
YCRS0140SC		#6 - 1/0 AWG	# 8 - 2 AWG	#4 - 300 KCM	# 8 - 2 AWG	#4 - 300 KCM	# 8 - 2 AWG
YCRS0180SC		#2 - 4/0 AWG	# 8 - 2 AWG	#4 - 300 KCM	# 8 - 2 AWG	#4 - 300 KCM	# 6 - 1/0 AWG
YCRS0200SC		#2 - 4/0 AWG	# 8 - 2 AWG	#4 - 300 KCM	# 8 - 2 AWG	#4 - 300 KCM	# 6 - 1/0 AWG
YCRS0220SC		#2 - 4/0 AWG	# 8 - 2 AWG	#4 - 300 KCM	# 8 - 2 AWG	#4 - 300 KCM	# 6 - 1/0 AWG
YCRS0240SC		#2 - 4/0 AWG	# 8 - 2 AWG	#4 - 300 KCM	# 8 - 2 AWG	#4 - 300 KCM	# 6 - 1/0 AWG
YCRS0100SC	-58	#18 - 2 AWG	# 8 - 2 AWG	#14 - 1/0 AWG	# 8 - 2 AWG	#14 - 1/0 AWG	# 8 - 2 AWG
YCRS0120SC		#6 - 1/0 AWG	# 8 - 2 AWG	#14 - 1/0 AWG	# 8 - 2 AWG	#2 - 4/0 AWG	# 8 - 2 AWG
YCRS0140SC		#6 - 1/0 AWG	# 8 - 2 AWG	#14 - 1/0 AWG	# 8 - 2 AWG	#2 - 4/0 AWG	# 8 - 2 AWG
YCRS0180SC		#6 - 1/0 AWG	# 8 - 2 AWG	#14 - 1/0 AWG	# 8 - 2 AWG	#4 - 300 KCM	# 8 - 2 AWG
YCRS0200SC		#6 - 1/0 AWG	# 8 - 2 AWG	#14 - 1/0 AWG	# 8 - 2 AWG	#4 - 300 KCM	# 8 - 2 AWG
YCRS0220SC		#6 - 1/0 AWG	# 8 - 2 AWG	#4 - 300 KCM	# 8 - 2 AWG	#6 - 350 KCM	# 6 - 1/0 AWG
YCRS0240SC		#2 - 4/0 AWG	# 8 - 2 AWG	#4 - 300 KCM	# 8 - 2 AWG	#6 - 350 KCM	# 6 - 1/0 AWG

5. Circuit breakers supplied by third party vendors must be certified by local electrical standards. Maximum size is based on 225% of the rated load amps for the largest motor plus 100% of the rated load amps for all other loads included in the circuit.
6. The "INCOMING WIRE RANGE" is the minimum and maximum wire size that can be accommodated by the unit wiring lugs. The (2) preceding the wire range indicates the number of termination points available per phase of the wire range specified. Actual wire size and number of wires per phase must be determined based on the National Electrical Code, using copper connectors only. Field wiring must also comply with local codes.
7. A ground lug is provided for each compressor system to accommodate a field grounding conductor per N.E.C. Table 250.122. A control circuit grounding lug is also supplied.
8. The supplied disconnect is a "Disconnecting Means" as defined in the N.E.C. 100.I, and is intended for isolating the unit for the available power supply to perform maintenance and troubleshooting. This disconnect is not intended to be a Load Break Device.
9. Field Wiring by others which complies to the National Electrical Code & Local Codes.

Electrical Data - Cont.

SINGLE POINT POWER SUPPLY (SEE FIG 10 & 11 , PAGE 36 & 37)

(One field provided power supply circuit to the control panel. Field connections to factory provided Terminal Blocks(opt) or Non-Fused Disconnect(opt). Individual system Circuit Breakers, Non-Fused Disconnects or Class 'J' Fuse/Fuse Blocks in each motor control center.)

CHILLER MODELS	VOLT CODE	MIN ⁽¹⁾ CIR MCA	MIN N/F DISC SW	MIN DUAL FUSE	MAX DUAL FUSE MAX CB	SYSTEM #1		SYSTEM #2	
						RLA	Y-D LRA	RLA	Y-D LRA
YCRS0100SC	200	387	400	450	500	172	404	172	404
	230	335	400	400	450	149	354	149	354
	380	203	250	250	250	90	219	90	219
	460	169	200	200	225	75	174	75	174
	575	135	150	175	175	60	138	60	138
YCRS0120SC	200	461	600	600	600	172	404	231	591
	230	400	600	500	600	149	354	201	481
	380	243	250	300	350	90	219	122	285
	460	201	250	250	300	75	174	101	228
	575	161	200	200	225	60	138	81	182
YCRS0140SC	200	520	600	600	700	231	591	231	591
	230	452	600	600	600	201	481	201	481
	380	275	400	350	350	122	285	122	285
	460	227	250	300	300	101	228	101	228
	575	182	200	225	250	81	182	81	182
YCRS0180SC	200	603	800	700	800	233	591	296	708
	230	526	600	600	700	203	481	258	642
	380	318	400	400	450	123	285	156	343
	460	262	400	300	350	101	228	129	280
	575	210	250	250	300	81	182	103	224
YCRS0200SC	200	666	800	800	800	296	708	296	708
	230	581	600	700	800	258	642	258	642
	380	351	400	400	500	156	343	156	343
	460	290	400	350	400	129	280	129	280
	575	232	250	300	300	103	224	103	224
YCRS0220SC	200	742	800	1000	1000	296	708	357	708
	230	646	800	800	800	258	642	310	642
	380	391	400	450	500	156	343	188	343
	460	323	400	400	450	129	280	155	280
	575	258	400	300	350	103	224	124	224
YCRS0240SC	200	803	1000	1000	1000	357	708	357	708
	230	698	800	800	1000	310	642	310	642
	380	423	600	500	600	188	343	188	343
	460	349	400	400	500	155	280	155	280
	575	279	400	350	400	124	224	124	224

Incoming Wire Range (Single Point)

SINGLE POINT POWER SUPPLY

MODEL NUMBER	SYSTEM # 1 & #2				
	VOLT CODE	TERM BLK	TERM BLK CUST. GROUND	N-F DIS SW	N-F DIS SW CUST. GROUND
YCRS0100SC	-17	#2/0 - 500 KCM	# 4 - 3/0 AWG	250 - 500 KCM	# 4 - 3/0 AWG
YCRS0120SC		(2) #2 - 300 KCM	(2) # 4 - 3/0 AWG	(2) 250 - 500 KCM	(2) # 4 - 3/0 AWG
YCRS0140SC		(2) #2 - 300 KCM	(2) # 4 - 3/0 AWG	(2) 250 - 500 KCM	(2) # 4 - 3/0 AWG
YCRS0180SC		(2) #2/0 - 500 KCM	(2) # 4 - 3/0 AWG	(2) 250 - 500 KCM	(2) # 4 - 3/0 AWG
YCRS0200SC		(2) #2/0 - 500 KCM	(2) # 4 - 3/0 AWG	(2) 250 - 500 KCM	(2) # 4 - 3/0 AWG
YCRS0220SC		(2) #2/0 - 500 KCM	(2) # 4 - 3/0 AWG	(2) 250 - 500 KCM	(2) # 4 - 4/0 AWG
YCRS0240SC		(2) #2/0 - 500 KCM	(2) # 4 - 3/0 AWG	(2) 250 - 500 KCM	(2) # 4 - 4/0 AWG
YCRS0100SC	-28	#2/0 - 500 KCM	# 4 - 3/0 AWG	250 - 500 KCM	# 4 - 3/0 AWG
YCRS0120SC		#2/0 - 500 KCM	# 4 - 3/0 AWG	250 - 500 KCM	# 4 - 3/0 AWG
YCRS0140SC		(2) #2 - 4/0 AWG	(2) # 6 - 1/0 AWG	(2) 250 - 500 KCM	(2) # 4 - 3/0 AWG
YCRS0180SC		(2) #2 - 300 KCM	(2) # 4 - 3/0 AWG	(2) 250 - 500 KCM	(2) # 4 - 3/0 AWG
YCRS0200SC		(2) #2 - 300 KCM	(2) # 4 - 3/0 AWG	(2) 250 - 500 KCM	(2) # 4 - 3/0 AWG
YCRS0220SC		(2) #2/0 - 500 KCM	(2) # 4 - 3/0 AWG	(2) 250 - 500 KCM	(2) # 4 - 3/0 AWG
YCRS0240SC		(2) #2/0 - 500 KCM	(2) # 4 - 3/0 AWG	(2) 250 - 500 KCM	(2) # 4 - 3/0 AWG
YCRS0100SC	-40	#2 - 4/0 AWG	# 8 - 2 AWG	#4 - 300 KCM	# 6 - 1/0 AWG
YCRS0120SC		#2 - 300 KCM	# 6 - 1/0 AWG	#4 - 300 KCM	# 6 - 1/0 AWG
YCRS0140SC		#2 - 300 KCM	# 6 - 1/0 AWG	#6 - 350 KCM	# 6 - 1/0 AWG
YCRS0180SC		#2/0 - 500 KCM	# 4 - 3/0 AWG	250 - 500 KCM	# 4 - 3/0 AWG
YCRS0200SC		#2/0 - 500 KCM	# 4 - 3/0 AWG	250 - 500 KCM	# 4 - 3/0 AWG
YCRS0220SC		#2/0 - 500 KCM	# 4 - 3/0 AWG	250 - 500 KCM	# 4 - 3/0 AWG
YCRS0240SC		#2/0 - 500 KCM	# 4 - 3/0 AWG	250 - 500 KCM	# 4 - 3/0 AWG
YCRS0100SC	-46	#2 - 4/0 AWG	# 8 - 2 AWG	#4 - 300 KCM	# 6 - 1/0 AWG
YCRS0120SC		#2 - 4/0 AWG	# 8 - 2 AWG	#4 - 300 KCM	# 6 - 1/0 AWG
YCRS0140SC		#2 - 4/0 AWG	# 8 - 2 AWG	#4 - 300 KCM	# 6 - 1/0 AWG
YCRS0180SC		#2 - 300 KCM	# 6 - 1/0 AWG	#6 - 350 KCM	# 6 - 1/0 AWG
YCRS0200SC		#2 - 300 KCM	# 6 - 1/0 AWG	250 - 500 KCM	# 4 - 3/0 AWG
YCRS0220SC		#2/0 - 500 KCM	# 4 - 3/0 AWG	250 - 500 KCM	# 4 - 3/0 AWG
YCRS0240SC		#2/0 - 500 KCM	# 4 - 3/0 AWG	250 - 500 KCM	# 4 - 3/0 AWG
YCRS0100SC	-58	# 2/0 - 500 KCM	# 8 - 2 AWG	#2 - 4/0 AWG	# 8 - 2 AWG
YCRS0120SC		(2) # 2 - 4/0 AWG	# 8 - 2 AWG	#2 - 4/0 AWG	# 8 - 2 AWG
YCRS0140SC		(2) # 2 - 300 KCM	# 8 - 2 AWG	#6 - 350 KCM	# 6 - 1/0 AWG
YCRS0180SC		(2) # 2/0 - 500 KCM	# 8 - 2 AWG	#6 - 350 KCM	# 6 - 1/0 AWG
YCRS0200SC		(2) 2/0 - 500 KCM	# 8 - 2 AWG	#6 - 350 KCM	# 6 - 1/0 AWG
YCRS0220SC		(2) 2/0 - 500 KCM	# 6 - 1/0 AWG	#6 - 350 KCM	# 6 - 1/0 AWG
YCRS0240SC		(2) 2/0 - 500 KCM	# 6 - 1/0 AWG	#6 - 350 KCM	# 6 - 1/0 AWG

Customer Wiring Data

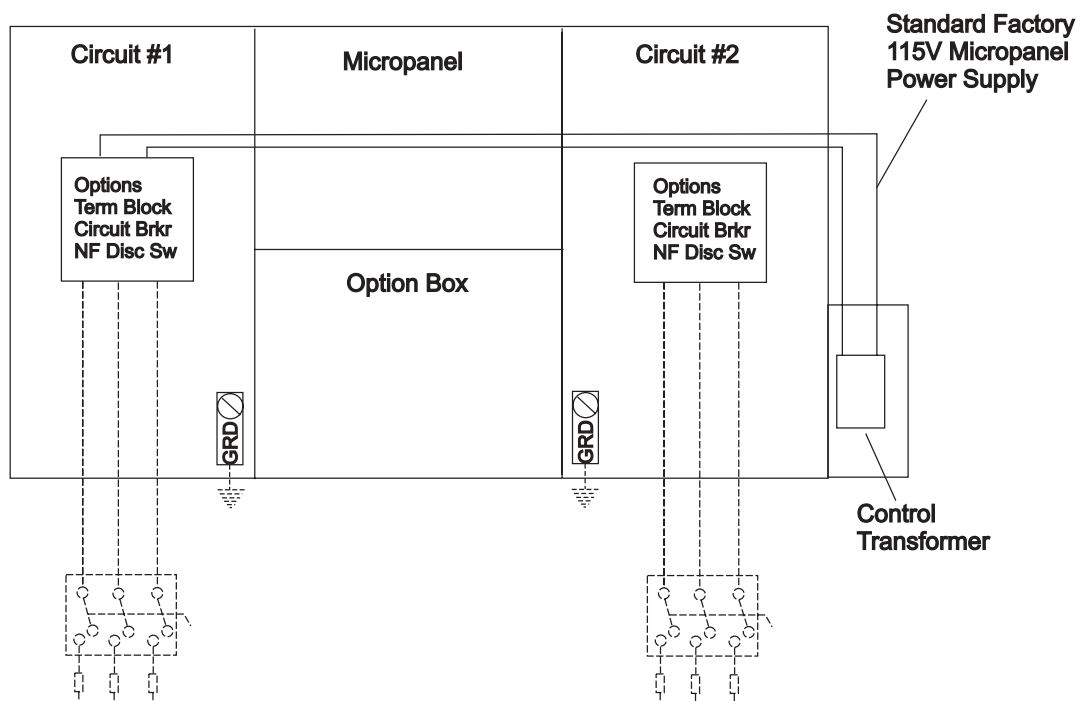

FIGURE 9 - MULTIPOINT POWER SUPPLY CONNECTION - STANDARD UNIT

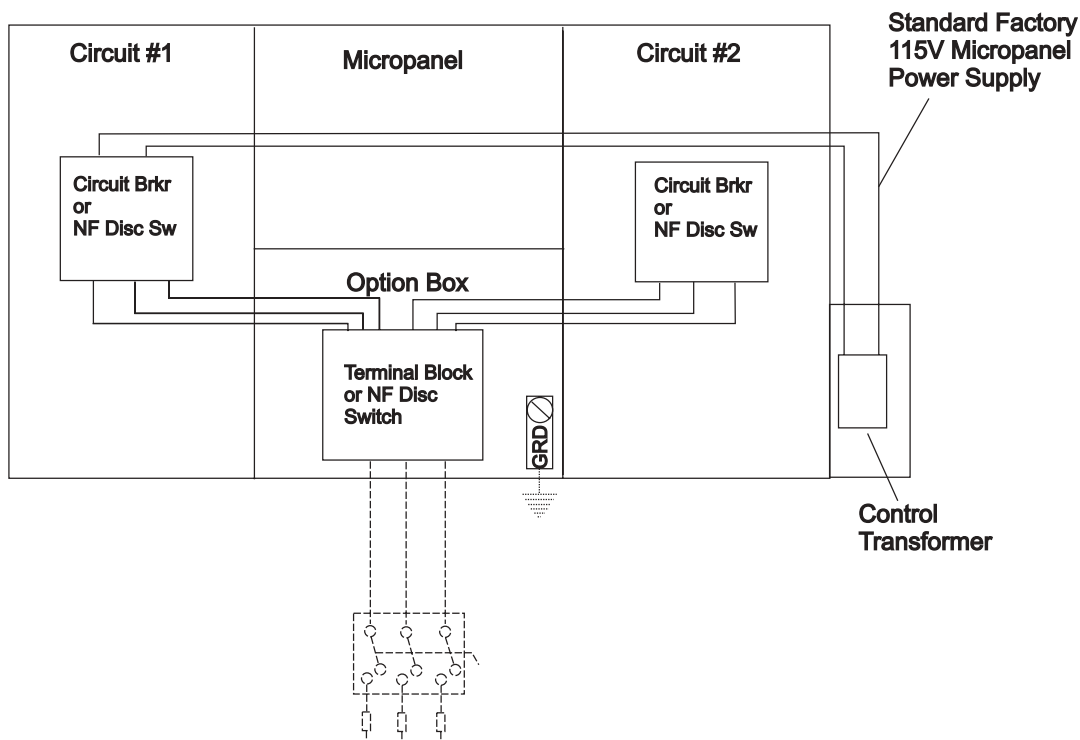

FIGURE 10 - SINGLE POINT POWER SUPPLY WITH INTERNAL CIRCUIT BREAKER OR NON-FUSED DISCONNECT SWITCH

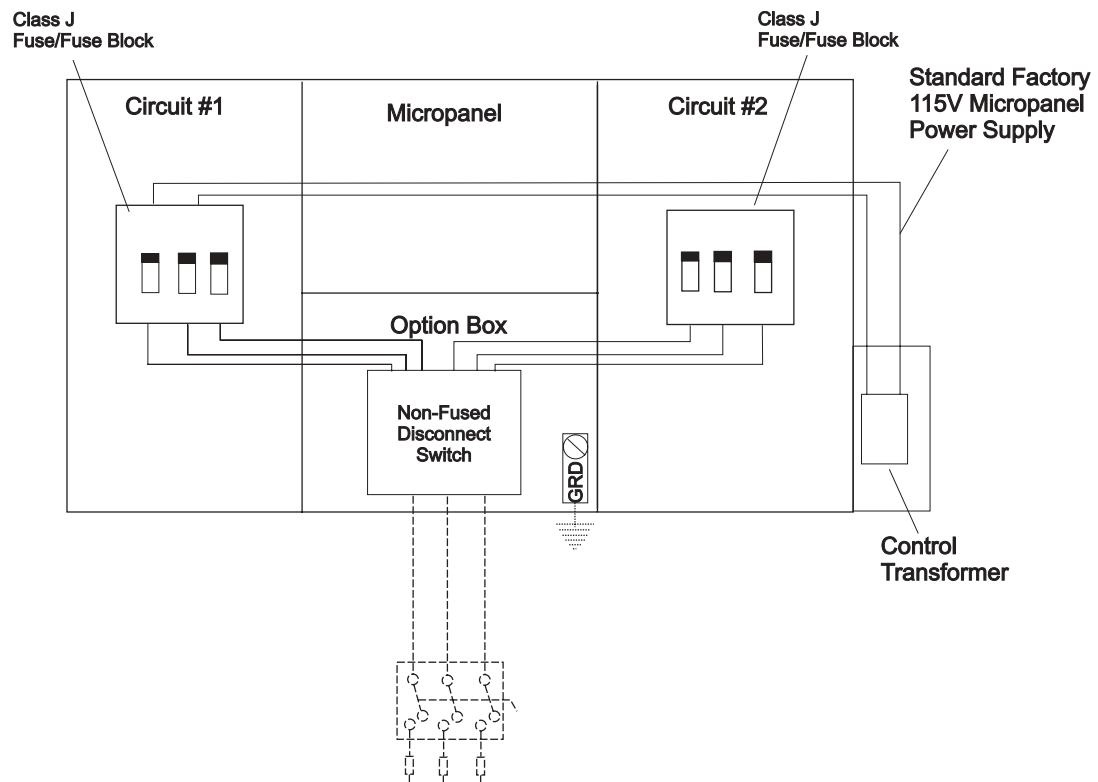

FIGURE 11 - OPTIONAL SINGLE POINT POWER SUPPLY WITH INTERNAL CLASS J FUSES/BLOCK

Notes:

1. Dashed line indicates field provided wiring
2. The above recommendations are based upon the National Electric Code and the use of copper connectors only. Field wiring must comply with local codes.
3. Single point Non-Fused Disconnect Switch is not offered with additional separate Non-Fused Disconnect Switches

VOLTAGE CODE

17 = 200-3-60

28 = 230-3-60

40 = 380-3-60

46 = 460-3-60

58 = 575-3-60

LEGEND

TERM BLOCK

C.B.

NF DISC SW

D.F.

DISC SW

HZ

MAX

MCA

MIN

MIN NF

RLA

Y-D LRA

TERMINAL BLOCK (FACTORY MOUNTED)

CIRCUIT BREAKER (FACTORY MOUNTED)

NON-FUSED DISCONNECT SWITCH (FACTORY MOUNTED)

DUAL FUSE

DISCONNECT SWITCH

HERTZ

MAXIMUM

MINIMUM CIRCUIT AMPACITY

MINIMUM



MINIMUM NON FUSED

RATED LOAD AMPS

WYE-DELTA INRUSH LOCKED ROTOR AMPS

Typical Control Panel Wiring

LEGEND

- TS TRANSIENT VOLTAGE SUPPRESSION
-  TERMINAL BLOCK FOR CUSTOMER CONNECTIONS. -XCCTB
-  TERMINAL BLOCK FOR CUSTOMER LOW VOLTAGE (CLASS 2) CONNECTIONS. SEE NOTE 2. -XTBI
-  TERMINAL BLOCK FOR YORK CONNECTIONS ONLY
- WIRING AND COMPONENTS BY YORK
- - - - - OPTIONAL EQUIPMENT
- - - - - WIRING AND/OR COMPONENTS BY OTHERS

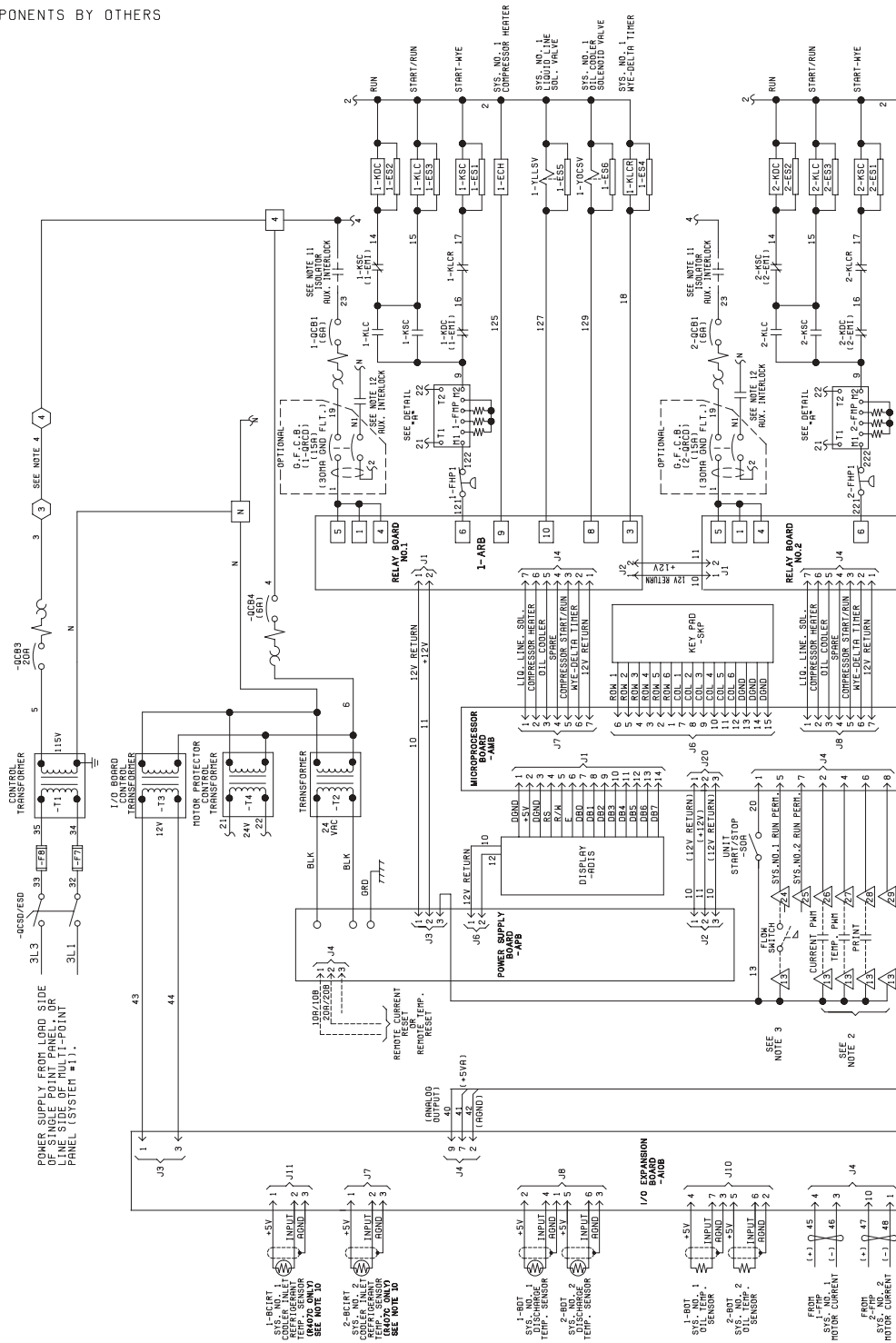

NOTES:

1. FIELD WIRING TO BE IN ACCORDANCE WITH THE CURRENT EDITION OF THE NATIONAL ELECTRICAL CODE AS WELL AS ALL OTHER APPLICABLE CODES AND SPECIFICATIONS.
2. CONTACTS MUST BE SUITABLE FOR SWITCHING 24VDC. (GOLD CONTACTS RECOMMENDED). WIRING SHALL NOT BE RUN IN THE SAME CONDUIT WITH ANY LINE VOLTAGE (CLASS 1) WIRING.
3. TO CYCLE UNIT ON AND OFF AUTOMATICALLY WITH CONTACT SHOWN, INSTALL A CYCLING DEVICE IN SERIES WITH THE FLOW SWITCH (TB 13 & 24 OF -XTBI) SEE NOTE 2 FOR CONTACT RATING AND WIRING SPECIFICATIONS.
4. TO STOP UNIT IMMEDIATELY (EMERGENCY STOP) REMOVE JUMPER WKI AND INSTALL AN E-STOP SWITCH OR CONTACTS BETWEEN TERMINALS 3 AND 4 OF -XCCTB.
5. ALARM CONTACTS - CUSTOMER SUPPLIED POWER SUPPLY TO COMMON TBI OF -ACRB. ALARM OUTPUTS ARE TB8 FOR SYSTEM 1 AND TB7 FOR SYSTEM 2 OF -ACRB.
6. SEE INSTALLATION, OPERATION AND MAINTENANCE MANUAL WHEN OPTIONAL EQUIPMENT IS USED.
7. CHILLER RUN CONTACTS - INDICATE WHEN ANY COMPRESSOR SYSTEM IS RUNNING. CHILLER RUN CONTACTS ARE TB3 AND TB4 OF -ACRB RELAY BOARD.
8. EVAPORATOR PUMP CONTACTS - MAY BE USED TO OPERATE CHILLER EVAPORATOR PUMP IN CONJUNCTION WITH OTHER CONTROLS. EVAPORATOR PUMP CONTACTS ARE TB5 & TB6 OF -ACRB.
9. CONTACTS ARE RATED FOR 115VAC, 100VA RESISTIVE LOAD ONLY. LOAD MUST BE SUPPRESSED AT SOURCE BY USER.
10. COOLER INLET REFRIGERANT SENSORS FITTED ONLY ON R-407C CHILLERS.
11. WHEN ISOLATOR IS NOT INSTALLED (OPTIONAL EQUIPMENT) A JUMPER IS INSTALLED TO COMPLETE THE CIRCUIT.

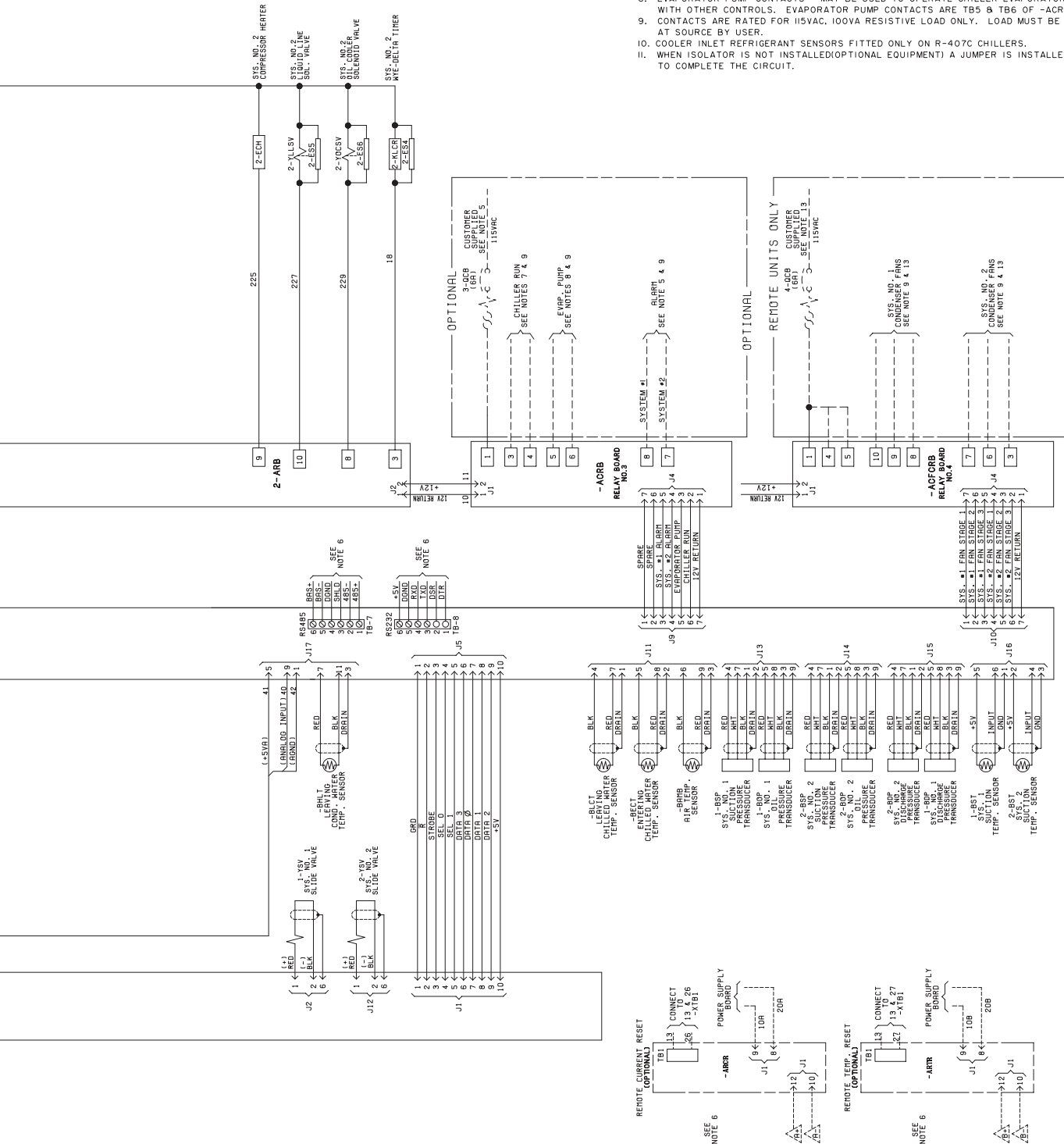

Application Data

UNIT LOCATION

Chillers may be placed on the ground floor or upper floor of the building. The floor must be level and capable of supporting 150% of the operating weight of the unit. Units should be located away from noise-critical areas. Service clearance must be allowed and include space for removing cooler or condenser tubes. A doorway or window can sometimes provide space for tube removal. Units should be installed indoors where they are not exposed to rain or water splash. Chillers should be located near a drain. The use of chillers in corrosive, dusty or explosive atmospheres should be avoided unless the unit is properly protected. A unit located in a clean room will run best, require least maintenance, and last longest. Heat or ventilation may be required to maintain the ambient between 40°F and 115°F (4.4°C and 46.1°C).

UNIT ISOLATION

The chiller foundation must be rigid to reduce vibration transmission to a minimum. All upper story installations should use vibration isolators under the unit base. To maintain isolator efficiency, no mechanical ties should be made to the building. Properly selected flexible connectors and piping isolators are recommended. All the above recommendations will help to reduce vibration transmission and result in a quieter operation.

FIELD CONNECTED WATER PIPING

Piping must comply in all respects with applicable local plumbing codes and ordinances. In no case should the unit support the weight of connecting piping. Since elbows, tees, and valves increase pressure drop, all piping should be kept as simple as possible. Hand stop valves should be installed where required to facilitate servicing. Piping to the inlet and outlet connections of the cooler and condenser may include high-pressure rubber hose or piping loops to ensure against water pump transmission of vibration.

Facilities should be provided for measuring temperature and pressure in the cooler and condenser field water piping. Drain connections should be provided at all low points to permit complete drainage of the cooler(s), condenser(s), and system piping. This is especially important if the unit is located in an unheated room where freezing could prevail. Water lines subjected to ambient temperatures below freezing may require heater cables or antifreeze (by others).

Water loops should contain provisions for venting. A strainer, preferably 40 mesh, should be installed in the cooler and condenser inlet lines, and located where it will protect the circulating pump and the heat exchanger tube bundles. It should be determined that the maximum water pressure at the cooler or condenser does not ex-

ceed the maximum design working pressure of the cooler or condenser.

The water circulating pumps should be located on the inlet side of the heat exchangers. If, however, space does not permit this, the pumps may be located in the outlet water piping. The net positive suction head must be considered when applying pumps.

REMOTE AIR COOLED CONDENSERS

Where the chiller is used in conjunction with a remote air-cooled condenser, the condenser should be located as close to the chiller as possible. This will minimize refrigerant piping pressure drop. Adequate subcooling must be provided to assure liquid refrigerant at the thermal expansion valve in a subcooled state. Refer to ARI/ASHRAE piping information and QA Helpful Tools -

(<http://intranet.york.com/web0061/?bu=ESG&cid=28>).

PARALLEL CHILLER APPLICATION

Multiple chillers are often used to provide increased reliability, reserve capacity, or to divide the design capacity. The standard factory packaged chiller is most compatible with parallel chilled liquid flow. Series flow arrangements are less desirable for pre-engineered packaged units due to excessive chilled liquid flow rate and higher pressure drops. YORK recommends that standard package chillers be arranged for parallel chilled liquid flow.

FIELD WIRING

All field wiring must comply with the National Electric Code and all applicable local codes. YORK liquid chiller units are factory wired for optimum reliability. Therefore the unit controls must not be modified without expressed written consent by YORK. The use of a simple switch or timer from a remote point is permitted; but it must be connected to the YORK unit panel at points expressly indicated for that purpose.

Guide Specifications

YORK Model YCRS _____ Packaged Chiller(s). The (each) unit shall have a cooling capacity of _____ tons with Compressor kW when cooling GPM of water from _____ °F (°C) to _____ °F (°C) and with _____ GPM of condensing water entering at _____ °F (°C) and leaving at _____ °F (°C), and a cooler fouling factor of _____ and condenser water fouling factor of _____. The water pressure drop shall not exceed _____ feet (kPa) of water through the cooler. The unit overall dimensions shall not exceed _____ feet (mm) _____ ins. in length, _____ feet (mm) _____ ins. in width and _____ feet (mm) _____ in height. The unit operating weight shall not exceed _____ lbs. (Kg).

GENERAL

The (Each) Packaged Water Cooled Remote Chiller shall be completely factory assembled (in an ISO 9001 registered facility) including all interconnecting refrigerant piping and internal wiring of controls, mounted on a steel base which accommodates the compressor(s) and evaporator. Operating test shall include operation with water flowing through the evaporator.

Unit can be painted with an optional coat of Caribbean Blue enamel overspray. The unit will be pressure-tested, evacuated, and charged with dry Nitrogen (N₂) for shipment, and York 'L' (POE) synthetic oil. The discharge and liquid lines will be capped and plugged. They will be removed in the field when connecting this unit with a air-cooled condenser. There will be an operational test, with water flowing through the cooler, to check that each control device operates correctly.

All units shall be designed and constructed in accordance with the applicable sections of the following: American Society of Heating, Refrigeration and Air Conditioning Engineers ANSI/ASHRAE 15 Safety Code for Mechanical Refrigeration; American Society of Mechanical Engineers ASME Pressure Vessel Code; National Electrical Code/ National Fire Protection Association NFPA 70. The unit shall be produced at an ISO 9001 registered facility. All chillers are rated in accordance with ARI Standard 550/590.

COMPRESSORS

Compressors shall be direct drive, semi-hermetic, rotary twin-screw type, including: internal muffler, temperature actuated, off-cycle heater, terminal box, internal discharge check, discharge and suction shutoff service valves, and precision machined cast iron housing. Design working pressure of entire compressor, suction to discharge, shall be 31 bar (450psig).

Motors shall feature refrigerant suction-gas cooled two-

pole accessible hermetic compressor motor, full suction gas flow through a mesh screen, with inherent internal thermal overload protection and external current overload on all three phases. Motor stator shall employ APT2000 type magnet wire.

Lubrication shall feature external oil separators with no moving or fragile parts, 31 bar (450psig) design working pressure, and UL listing. Refrigerant system differential pressure shall provide oil flow through service replaceable, 0.5 micron, full flow, cartridge type oil filter internal to compressor. Filter bypass, less restrictive media, or oil pump not acceptable.

Compressors shall start at minimum load position. Capacity control range from 100% to 10% of chiller full load using continuous function slide valves, and without hot gas bypass. Step unloading unacceptable. Provide Microprocessor controlled, output pressure regulating capacity control valve to command compressor capacity independent of control valve input pressure and balance compressor capacity with cooling load.

CAPACITY CONTROL SYSTEM

Continuous function, microprocessor controlled, 3- way proportional Capacity Control Valve provides regulated output pressure independent of valve input pressure for a stable, smooth, and precise match of compressor capacity to cooling load to 10% of chiller capacity.

COOLER

The cooler shall be a direct expansion shell and tube type with refrigerant in the tubes and liquid to be chilled in the shell. The design working pressure of the cooler shell side (liquid) shall be 150 PSIG and for the tube side (refrigerant), the design working pressure shall be 300 PSIG. Refrigerant heads shall be removable. The cooler shall be covered with 3/4" flexible closed cell foam insulation (K = 0.25 maximum) to prevent sweating. The cooler shall be constructed and tested in accordance with ASME Code requirements. Vent and drain connections shall be included. The water connections shall be fully accessible and grooved to accept victaulic couplings if used (by others).

REFRIGERANT CIRCUIT

Two independent refrigerant circuits will be furnished on each unit. All piping will be copper with brazed joints. The liquid lines will be capped before the liquid dryer angle valve and will include: a shutoff valve with charging port; sightglass with moisture indicator; thermal expansion valve; solenoid valve; and high-absorption removable-core

Guide Specifications - Cont.

filter drier. The entire suction line and the liquid line between the expansion valve and the cooler will be insulated with flexible, closed-cell, foam insulation.**MICROCOMPUTER CONTROL CENTER**

Each unit shall contain a Microcomputer Control Center. All logic and controls shall be contained within a IP 32 (NEMA 1) cabinet with hinged outer door with positive acting latches. Inside shall be contained the “user friendly” and interactive inputs and outputs as follows: LCD display with light emitting diode back lighting for easy viewing of data and input buttons for DISPLAY (temperatures, pressure, etc.), ENTRY (enter/cancel inputs, advance day, change AM/PM), SETPOINTS (change), CLOCK (set time and schedule), PRINT (calling up operating and shutdown data), PROGRAM (change inputs from special conditions such as brine chilling) and UNIT ON/OFF.

The Microcomputer Control Center shall be capable of displaying the following: return and leaving liquid temperature; return and leaving condenser water temperature (optional); low leaving liquid temperature cutout setting; system 1 and 2 percent full-load motor current and suction, discharge (optional) and oil differential pressures; liquid pulldown control range (selectable for 0.6°C to 1.1°C [1°F to 2°F] in one-tenth increments above the setpoint); liquid pull-down rate sensitivity (0.3°C to 3.0°C [0.5°F to 5°F]/minute in 0.05°C [0.1°F] increments); anti-recycle timer status; compressor run status; no cooling load condition; day; date; time; out of range message; daily and

holiday scheduling of start/stop times; automatic or manual lead/lag status; lead compressor definition; number of compressor starts and running hours; status of hot gas bypass valves (option), liquid line solenoid valves, and water pump; last three fault shutdowns data; number of unloading steps; compressor load and unload timer status.

The operating program shall be stored in nonvolatile memory (EPROM) to eliminate chiller failure due to AC power failure/battery discharge. Programmed setpoints are retained in lithium battery – backed RTC memory for 5 years minimum.

Provisions shall be included for: pumpdown at shutdown and recycling pumpdown; a hard copy printout from a printer (by others) via an RS-232 electrical output; two steps of demand load limiting and remote chilled liquid reset from an external building automation system; unit alarm contacts; chilled water pump or remote air-cooled condenser control; or Remote Control with printout capability (up to 2000 feet) via an RS-485 electrical output.

POWER PANEL

The power panel shall contain the compressor power terminals. U.L. recognized compressor motor starting contactors which meet I.E.C. requirements, current transformer sensing for each compressor power source, for protection against under current, over current, imbalanced current, single phasing compressor stall and voltage spikes.



P.O. Box 1582, York, Pennsylvania USA 17405-1522
Copyright © by York International Corporation 2001

Form 201.25-EG1 (202)
New Release

Tel: 800-861-1001
www.york.com

Subject to change without notice. Printed in USA
ALL RIGHTS RESERVED

RPC 2M 202 4,16
Codes: DXS, ET