

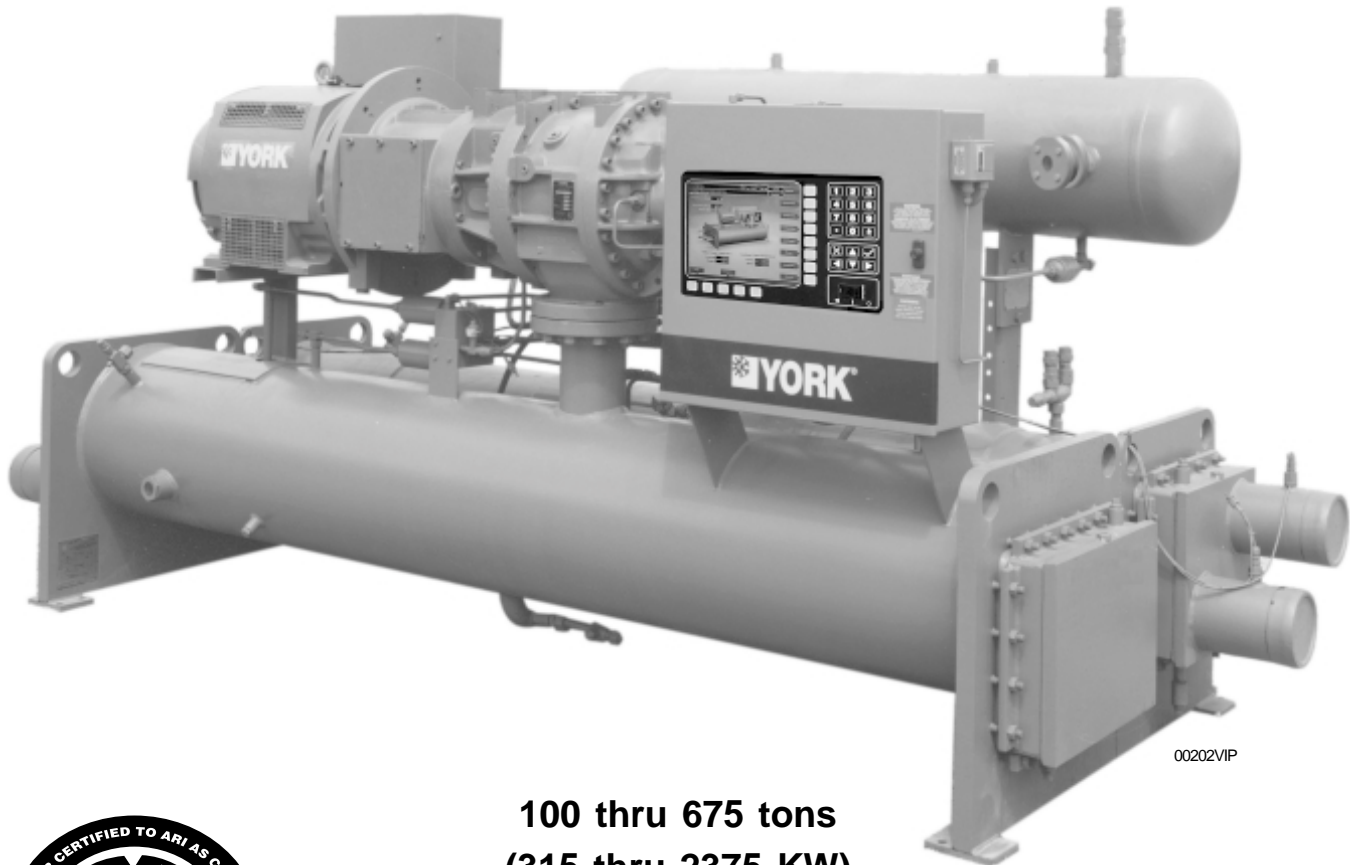

MILLENNIUM[®]
Model YS
Rotary Screw Liquid Chillers
Design Level E



00202VIP

100 thru 675 tons
(315 thru 2375 KW)

R-22 and R-134a



Rated in Accordance
with the latest edition of
ARI STANDARD 550/590

**NOTE: YS CHILLERS
ARE YEAR 2000 COMPLIANT**



Metric Conversions

TABLE OF CONTENTS

	<u>PAGE</u>
INTRODUCTION	3
RATINGS	4
OPTIVIEW CONTROL CENTER	5
MECHANICAL SPECIFICATIONS	13
ACCESSORIES & MODIFICATIONS	17
UNIT COMPONENTS	19
APPLICATION DATA	20
DIMENSIONS – STD	28
S0-S3 Compressor	28
S4 & S5 Compressor	29
Compact Water Box Nozzle Arrangements	30
Floor Layout	31
Cooler Nozzle Arrangements	32
Condenser Nozzle Arrangements	34
WEIGHTS – STD	36
DIMENSIONS – METRIC	38
S0-S3 Compressor	38
S4 & S5 Compressor	39
Compact Water Box Nozzle Arrangements	40
Floor Layout	41
Cooler Nozzle Arrangements	42
Condenser Nozzle Arrangements	44
WEIGHTS – METRIC	46
GUIDE SPECIFICATIONS	48
METRIC CONVERSION TABLES	53

LIST OF TABLES

<u>TABLE NO.</u>		<u>PAGE</u>
1	Water Flow Rate Limits	20
2	Motor Voltage Variations	23
3	60 Hz Electrical Data	25
4	Motor Starters	25
5	50 Hz Electrical Data	26
6	Available Compressor/Shell/ Motor Combinations (R-22 & R-134a)	26
7	Available Compressor/Shell/ Motor Combinations (50 Hz, R-134a Only)	27

NOMENCLATURE

The model number denotes the following characteristics of the unit:

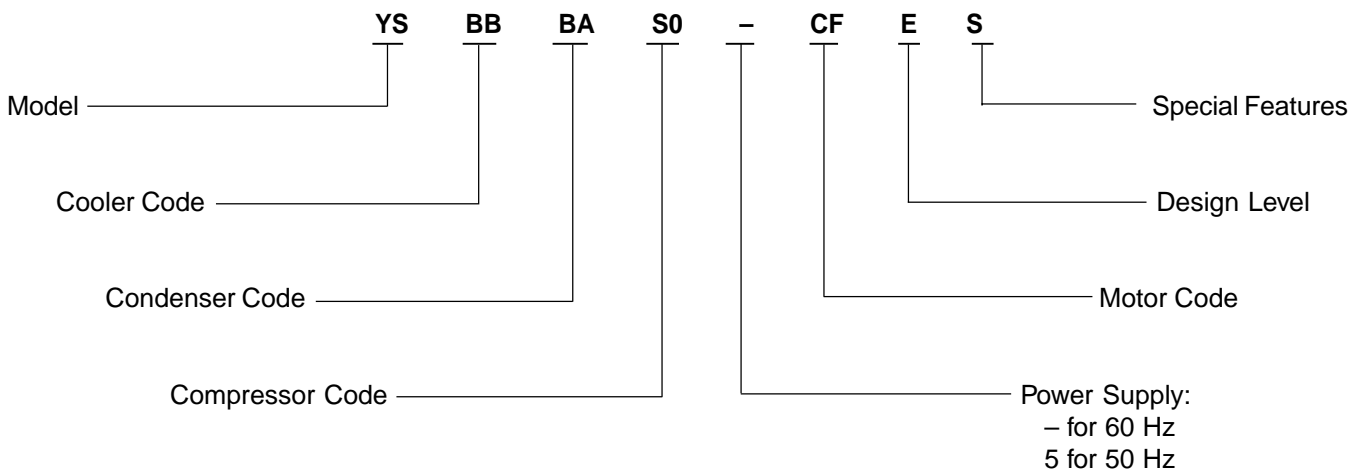

Introduction

The YORK *Millennium* YS Chiller offers a complete combination of features for total owner satisfaction.

MATCHED COMPONENTS MAXIMIZE EFFICIENCY

Actual chiller efficiency cannot be determined by analyzing the theoretical efficiency of any one chiller component. It requires a specific combination of heat exchanger, compressor, and motor performance to achieve the lowest system kW/Ton. YORK *Millennium* chiller technology matches chiller system components to provide maximum chiller efficiency under actual – not just theoretical – operating conditions.

REAL-WORLD ENERGY PERFORMANCE

YORK pioneered the term “Real-World Energy” to illustrate the energy-saving potential of focusing on chiller performance during off-design conditions. Off-design is not only part load, but full load operation as well, with reduced entering condenser water temperatures (ECWTs). This is where chillers operate 99% of the time, and where operating costs add up.

The YS *Millennium* chillers are the only chillers designed to operate on a continuous basis with cold ECWT and full condenser flow at all load points, taking full advantage of Real-World conditions. This type of operation benefits the cooling tower as well; reducing cycling of the fan motor and ensuring good coverage of the cooling fill.

YORK *Millennium* chillers offer the most efficient Real-World operation of any chiller, meaning lower operating costs and an excellent return on your chiller investment.

OPEN DRIVE DESIGN

Hermetic-motor burnout can cause catastrophic damage to a chiller. The entire chiller must be cleaned, and the refrigerant replaced. YORK *Millennium* screw chillers eliminate this risk by utilizing air-cooled motors. Refrigerant never comes in contact with the motor, preventing contamination of the rest of the chiller.

Insurance companies that offer policies on large air conditioning equipment often consider air-cooled motors a significant advantage over hermetic refrigerant cooled units.

HIGH-EFFICIENCY HEAT EXCHANGERS

Millennium chiller heat exchangers offer the latest technology in heat transfer surface design to give you maximum efficiency and compact design. Water-side and refrigerant-side design enhancements minimize both energy consumption and tube fouling.

FACTORY PACKAGING REDUCES FIELD LABOR COSTS

YORK *Millennium* screw chillers are designed to keep installation costs low. Where installation access is not a problem, the unit can be shipped completely packaged, requiring minimal piping and wiring to complete the installation.

For those units utilizing a factory installed Solid-State Starter, the three power leads provide all power to the chiller and its auxiliaries.

TAKE ADVANTAGE OF COLDER COOLING TOWER WATER TEMPERATURES

YORK *Millennium* screw chillers are designed to take full advantage of colder cooling tower water temperatures, which are naturally available during most operating hours. Considerable energy savings are available by letting tower water temperature drop, rather than artificially holding it above 75°F (23.9°C), especially at low load, as some chillers require.

U.L. ACCEPTANCE – YOUR ASSURANCE OF RELIABILITY

YORK *Millennium* screw chillers are approved for listing by Underwriter’s Laboratories for the United States and Canada. Recognition of safety and reliability is your assurance of trouble-free performance in day-to-day building operation.

Ratings



Rated in accordance with the latest issue of ARI Standard 550/590.

ARI CERTIFICATION PROGRAM

The performance of YORK *Millennium* chillers is certified to the Air Conditioning and Refrigeration Institute (ARI) complying with the certification sections of the latest issue of ARI Standard 550/590. Under this Certification Program, chillers are regularly tested in strict compliance with this Standard. This provides an independent, third-party verification of chiller performance.

COMPUTERIZED PERFORMANCE RATINGS

Each chiller is custom-matched to meet the individual building load and energy requirements. A large number of standard heat exchangers and pass arrangements are available to provide the best possible match.

It is not practical to provide tabulated performance for each combination, as the energy requirements at both full and part-load vary significantly with each heat exchanger and pass arrangement. Computerized ratings are available through each YORK sales office. These

ratings can be tailored to specific job requirements, and are part of the ARI Certification Program.

OFF-DESIGN PERFORMANCE

Since the vast majority of its operating hours are spent at off-design conditions, a chiller should be chosen not only to meet the full-load design, but also for its ability to perform efficiently at lower loads and lower tower water temperatures. It is not uncommon for chillers with the same full-load KW/TON to have an operating cost difference of over 10% due to part-load operation.

Part-load information can be easily and accurately generated by computer. And because it is so important to an owner's operating budget, this information is now standard within the ARI Certification Program in the form of an Integrated Part-Load Value (IPLV), and Non-Standard Part-Load Value (NPLV).

The IPLV / NPLV formulas from ARI Standard 550/590 closely track chiller operations, and provide a more accurate indication of chiller performance than the previous IPLV / APLV formula. A more detailed analysis must take into account actual building load profiles, and local weather data. Part-load performance data should be obtained for each job using its own design criteria.

OptiView Control Center



OPTIVIEW CONTROL CENTER

The YORK OptiView Control Center, furnished as standard on each chiller, provides the ultimate in efficiency, monitoring, data recording, chiller protection and operating ease. The control center is a factory mounted, wired and tested state-of-the-art microprocessor based control system for R-134a or R-22 screw chillers. The panel is configured with a 10.4 inch diagonal color Liquid Crystal Display (LCD) surrounded by "soft" keys, which are redefined with one keystroke based on the screen display at that time. This revolutionary development makes chiller operation quicker and easier than ever before. Instead of requiring keystroke after keystroke to hunt for information on a small monochrome LCD screen, a single button reveals a wide array of information on a large, full-color illustration of the appropriate component, which makes information easier to interpret. This is all mounted in the middle of a keypad interface and installed in a locked enclosure.

The LCD display allows graphic animated display of the chiller, chiller sub-systems and system parameters; this allows the presentation of several operating parameters at once. In addition, the operator may view a graphical representation of the historical operation of the chiller as well as the present operation. A Status Bar is displayed at all times on all screens. It contains the System - Status Line and Details Line, the Control Source, Access Level, Date and Time. All date representations and calculations use four digits for the year to provide Year 2000 compliance.

During the Start Sequence and System Lockout Delay, the system status will include a countdown timer indicating the time remaining. The control panel is compatible with the YORK Solid State Starter (optional), Electro-mechanical (E-M) starter, or any customer supplied E-M starter that complies with the YORK R-1051 standard. The locations of various chiller parameters are clearly marked and instructions for specific operations are provided. The panel verbiage is available in other languages as an option, with English always available. Data can be displayed in either English or Metric units, plus keypad entry setpoints of 0.1 increments.

Security access is provided to prevent unauthorized change of setpoints. This is accomplished with three different levels of access and passwords for each level. There are screens, displayed values, programmable setpoints and manual controls not shown available to service the chiller. They are only displayed when logged in at the service access level. The Advanced Diagnostics and troubleshooting information for the chiller and the panel is also included.

The panel is fused through a 1-1/2 or 2 KVA transformer in the compressor motor starter to provide individual over-current protected power for all controls. Numbered terminal strips for wiring such as Remote Start/Stop, Flow Switch, Chilled Water Pump and Local or Remote Cycling Device are provided. The Panel also provides field interlocks that indicate the chiller status. These contacts include a Remote Mode Ready To Start, a Cycling Shut-

OptiView Control Center (continued)

down, a Safety Shutdown and a chiller Run Contact. Pressure transducers sense system pressures and thermistors sense system temperatures. The output of each transducer is a DC voltage that is analogous to the pressure input. The output of each thermistor is a DC voltage that is analogous to the temperature it is sensing.

Setpoints can be changed from a remote location via 0-10VDC, 4-20mA, contact closures or through serial communications. The adjustable remote reset range [up to 20°F (11.1°C)] provides flexible, efficient use of remote signal depending on reset needs. Serial data interface to the YORK ISN Building Automation System (BAS) is through the General Protocol Interface Card (GPIC), which can be mounted inside the Control Center.

This printed circuit board requests the required data from the Micro Board and makes it available for the YORK ISN network. This optional board is available through the YORK BAS group. The operating program is stored in non-volatile memory (EPROM) to eliminate chiller failure due to AC power failure/battery discharge. Programmed setpoints are retained in lithium battery-backed RTC memory for 11 years minimum.

Smart Freeze Point Protection can operate the chiller as low as 36°F (2.22°C) leaving chilled water temperature, without nuisance trips on Low Water Temperature. The sophisticated program and sensor monitors the chiller water temperature to prevent freeze-up. Each programmable point has a pop-up screen with the allowable ranges, so the chiller cannot be programmed to operate outside of its design limits.

Thermal ice storage systems are based on the concept of using off-peak, lower cost electricity to build ice for handling the cooling load during peak hours. The most efficient way to build ice is to maximize chiller load and minimize run time. Standard chiller control systems are not designed for this operating mode. In a typical application, chillers will load and unload to maintain a leaving chilled liquid setpoint. When the YORK YS chiller operates in the thermal storage control mode, the unit will remain at 100% load until the setpoint shutdown temperature is reached. To add greater operating flexibility and eliminate unnecessary chiller cycling, two different Low Water (Liquid) Temperature Restart Thresholds can be programmed, one for the ice mode and one for the standard cooling mode. This control enhancement is standard on all YS chillers. The chiller can also be left in the standard control mode for temperatures ranging between 20 and 70°F (-6.7 and 21.1°C), for applications involving a process cooling duty that requires leaving chilled liquid temperature setpoint control.

When power is applied to the chiller, the **HOME** screen is displayed. This screen displays a visual representation of the chiller and a collection of data detailing important operations and parameters. When the chiller is running, the flow of chilled liquid is animated by the alternating shades of color moving in and out of the pipe nozzles. The primary values that need to be monitored and controlled are shown on this screen. They are as follows:

Display Only:

- Chilled Liquid Temperature – Leaving
- Chilled Liquid Temperature – Return
- Condenser Liquid Temperature – Return
- Condenser Liquid Temperature – Leaving
- Motor Run (LED)
- % Full Load Amps
- Operating Hours

With the “soft” keys the operator is only one touch away from the 8 main screens that allow access to the major information and components of the chiller. The 8 screens are the **SYSTEM, EVAPORATOR, CONDENSER, COMPRESSOR, OIL SUMP, MOTOR, SETPOINTS**, and the **HISTORY**. Also on the Home Screen is the ability to **Log IN, Log OUT** and **Print**. Log In and Log Out is the means by which different security levels are accessed.

The **SYSTEM** screen gives a general overview of common chiller parameters for both shells. This is an end view of the chiller with a 3-D cutaway of both the shells. The following can be viewed from this screen:

Display Only:

- Discharge Temperature
- Chilled Liquid Temperature – Leaving
- Chilled Liquid Temperature – Return
- Chilled Liquid Temperature – Setpoint
- Evaporator Pressure
- Evaporator Saturation Temperature
- Condenser Liquid Temperature – Leaving
- Condenser Liquid Temperature – Return
- Condenser Pressure
- Condenser Saturation Temperature
- Oil Temperature
- Differential Oil Pressure
- % Full Load Amps
- Current Limit
- Slide Valve Position

The **EVAPORATOR** screen displays a cutaway view of the chiller evaporator. All setpoints relating to the evaporator side of the chiller are maintained on this screen. Animation of the evaporation process indicates whether the chiller is presently in RUN condition (bubbling) and liquid flow in the pipes is indicated by alternating shades of color moving in and out of the pipes. Adjustable limits on the low water temperature setpoints allow the chiller to cycle on and off for greater efficiency and less chiller cycling. The chiller cycles off when the leaving chilled water temperature is below setpoint and is adjustable from 1°F (0.55°C) below to a minimum of 36°F (2.22°C). Restart is adjustable from setpoint up to a max of 80°F (44.4°C). The Panel will check for flow to avoid freeze-up of the tubes. If flow is interrupted, shutdown will occur after a minimum of two seconds. The following can also be performed through this screen:

Display Only:

- Chilled Liquid Flow Switch (Open/Closed)
- Chilled Liquid Pump (Run/Stop)
- Evaporator Pressure
- Evaporator Saturation Temperature
- Return Chilled Liquid Temperature
- Leaving Chilled Liquid Temperature
- Evaporator Refrigerant Temperature
- Small Temperature Difference
- Leaving Chilled Liquid Temperature Setpoints – Setpoint
- Leaving Chilled Liquid Temperature Setpoints – Remote Range
- Leaving Chilled Liquid Temperature Setpoints – Shutdown
- Leaving Chilled Liquid Temperature Setpoints – Shutdown Offset
- Leaving Chilled Liquid Temperature Setpoints – Restart
- Leaving Chilled Liquid Temperature Setpoints – Restart Offset
- Ice Storage Active (LED)

Programmable:

- Local Leaving Chilled Liquid Temperature – Range
- Local Leaving Chilled Liquid Temperature – Setpoint
- Leaving Chilled Liquid Temperature Cycling Offset – Shutdown
- Leaving Chilled Liquid Temperature Cycling Offset – Restart

The **CONDENSER** screen displays a cutaway view of the chiller condenser. The liquid flow is animated to indicate flow through the condenser. All setpoints relating to the condenser side of the chiller are maintained on this screen. With the proper access level this screen also serves as a gateway to controlling the Refrigerant Level. The following can also be viewed through this screen:

Display Only:

- Leaving Condenser Liquid Temperature
- Return Condenser Liquid Temperature
- Condenser Pressure
- Condenser Saturation Temperature
- Small Temperature Difference
- High Pressure Switch (Open/Closed)
- Condenser Liquid Flow Switch
- Condenser Liquid Pump (Run/Stop)

Programmable:

- High Pressure Warning Threshold
- Freeze Warning (Enabled/Disabled)
- Freeze Time

The **VARIABLE ORIFICE CONTROL** screen, accessed from the CONDENSER screen in SERVICE access level, displays all of the applicable Variable Orifice control parameters and allows a Service Technician to program the Delta P setpoint. The Low Evaporator Pressure and Superheat Override LED's are located on this screen. A view of the liquid flow piping to the chiller condenser, along with the solenoid flow control valve, is shown. The following can also be performed through this screen:

Display Only:

- Condenser Pressure
- Evaporator Pressure
- Delta P (Condenser – Evaporator)
- Discharge Temperature
- Condenser Saturation Temperature
- Superheat Temperature
- Low Evaporator Override (LED)
- Superheat Override (LED)

Programmable:

- Delta P Setpoint

OptiView Control Center (continued)

The **COMPRESSOR** screen displays a cutaway view of the chiller compressor, revealing the rotary screw, and shows all conditions associated with the compressor. The slide valve positioning is animated and with the proper Access level, it can be manually controlled. Animation of the compressor rotors indicates whether the chiller is presently in a **RUN** condition. This screen also serves as a gateway to sub-screens for calibrating the slide valve or configuring the optional Hot Gas Bypass. From this screen you can view the following:

Display Only:

- Differential Oil Pressure
- Oil Temperature
- Discharge Temperature
- Discharge Superheat
- Slide Valve Position
- Oil Return Solenoid (LED)
- Full Load Amps (E.M. Starter Only)
- Phase A, B, C Current (SSS Only)

Programmable:

- Slide Valve Load (Manual)
- Slide Valve Hold (Manual)
- Slide Valve Unload (Manual)
- Slide Valve Auto
- Max. Load Temperature
- Minimum Load FLA
- Minimum Load Control Source

The **HOT GAS BYPASS** screen, accessed from the **COMPRESSOR** screen, displays a pictorial of the bypass line and solenoid valve location on the chiller. The Hot Gas ON and OFF Setpoints are programmed on this screen and system parameters pertinent to Hot Gas Bypass operation are displayed. An LED illuminates when the Hot Gas solenoid is ON. If the chiller is equipped with the Hot Gas Bypass option, operation must be enabled on the **OPERATIONS** screen. From this screen you can perform the following:

Display Only:

- Slide Valve Position
- Return Chilled Liquid Temperature
- Leaving Chilled Liquid Temperature
- Hot Gas Solenoid (LED)

Programmable:

- On Setpoint
- Off Setpoint

The **SLIDE VALVE CALIBRATION** screen displays a cutaway view of the chiller compressor, revealing the rotary screw and slide valve and provides the capability of calibrating the slide valve. From this screen, you can perform the following:

Display Only:

- Slide Valve Loading (LED)
- Slide Valve Unloading (LED)
- Calibration Message

Programmable:

- Start Calibration
- Cancel Calibration

The **OIL SEPARATOR** screen displays a close-up view of the chiller oil separator/sump and provides all the necessary setpoints for maintaining the Variable Speed Oil Pump (VSOP). This screen also allows manual control of the Frequency Command sent to the VSOP. From this screen you can perform the following:

Display Only:

- Discharge Temperature
- Oil Sump Temperature
- Discharge Superheat
- Oil Pressure
- Filter Pressure
- Seal Pressure
- Differential Oil Pressure
- Differential Filter Pressure
- Differential Seal Pressure
- Offset Pressure
- Oil Return Solenoid (LED)
- Low Separator Oil Level (LED)

1. The **MOTOR** “soft” key on the **HOME** screen, when pressed, shows a picture of either a YORK Electro-Mechanical Starter or a Solid State Starter, depending on chiller configuration. The Programmable pulldown demand to automatically limit motor loading can be used to minimize building demand charges.

Pulldown time period control over four hours, and verification of time remaining in pulldown cycle from display readout. Separate digital setpoint for current limiting between 30 and 100%.

The **ELECTRO-MECHANICAL STARTER (E-M)** screen displays a picture of the starter and the following values. The ones below are common among both offerings and the values will be displayed on both types of starter screens. From this screen you can perform the following:

Display Only:

- Motor Run (LED)
- Motor Current % Full Load Amps
- Current Limit Setpoints
- Pulldown Demand Time Left

Programmable:

- Local Motor Current Limit
- Pulldown Demand Limit
- Pulldown Demand Time

The **SOLID STATE STARTER (SSS)** screen displays a picture of the starter and the following values, which are displayed in addition to the common ones listed above. From this screen, you can perform the following:

Display Only:

- Input Power
- kW Hours
- Starter Model
- Voltage – Phase A, B, C
- Current – Phase A, B, C
- Temperature – Phase A, B, C

Programmable:

- Full Load Amps
- Voltage Range
- Starting Current
- Open SCR
- Shorted SCR
- kWh Reset

The **SETPOINTS** screen provides a convenient location for programming the most common setpoints involved in the chiller control. The Setpoints are shown on other individual screens, but to cut down on needless searching, they can all be found on this screen. This screen also serves as a gateway to a sub-screen for defining the setup of general system parameters. From this screen you can perform the following:

Display Only:

- Leaving Chilled Liquid Temperature – Setpoint
- Leaving Chilled Liquid Temperature Cycling – Shutdown
- Leaving Chilled Liquid Temperature Cycling – Restart
- Current Limit Setpoint

Programmable:

- Local Leaving Chilled Liquid Temperature – Range
- Local Leaving Chilled Liquid Temperature – Setpoint
- Leaving Chilled Liquid Temperature Cycling Offset – Shutdown
- Leaving Chilled Liquid Temperature Cycling Offset – Restart
- Remote Analog Input Range
- Local Motor Current Limit
- Pulldown Demand Limit
- Pulldown Demand Time
- Print

The **SETUP** is the top level of the general configuration parameters. It allows programming of the time and date, along with specifications as to how the time will be displayed. In addition, the chiller configuration as determined by the micro board program jumpers and program switches is displayed. From this screen you can perform the following:

Display Only:

- Chilled Liquid Pump Operation (Displays *Standard* or *Enhanced*)
- Refrigerant Selection (Displays *R-22* or *R-134a*)
- Anti-Recycle (Displays *Disabled* or *Enabled*)
- Power Failure Restart (Displays *Manual* or *Automatic*)
- Liquid Type (Displays *Water* or *Brine*)

OptiView Control Center (continued)

Programmable:

- Set Date
- Set Time
- Clock (Enabled/Disabled)
- 12/24 Hour

The following six subscreens can be accessed from the **SETUP** screen:

The **SCHEDULE** screen contains more programmable values than a normal display screen. Each programmable value is not linked to a specific button; instead, the select key is used to enable the cursor arrows and check key to program the Start/Stop times for any day of the week up to **6 weeks** in advance. The user has the ability to define a standard set of Start/Stop times that are utilized every week or specify exceptions to create a special week.

Programmable:

- Exception Start/Stop Times
- Schedule (Enable/Disable)
- Repeat Sunday Schedule
- Standard Week Start/Stop Times
- Reset All Exception Days
- Select
- Print

The **USER** screen allows definition of the language for the chiller to display and defines the unit of measure.

Programmable:

- System Language
- English/Metric Units

The **COMMS** screen allows the user to define communications parameters.

Programmable:

- Chiller ID
- COM 2 Baud Rate
- COM 2 Data Bit(s)
- COM 2 Parity Bit(s)
- COM 2 Stop Bit(s)
- Printer Baud Rate
- Printer Data Bit(s)
- Printer Parity Bit(s)

- Printer Stop Bit(s)

The **PRINTER** screen permits the user to define communications Parameters for the Printer.

Display Only

- Time Remaining Until Next Print

Programmable

- Log Start Time
- Output Interval
- Automatic Printer Logging (Enabled/Disabled)
- Print Type
- Print Report
- Print All Histories

The **SALES ORDER** screen allows definition of the order parameters. *Note: This information is loaded at the factory or by the installation service technician.*

Display Only

- Model Number
- Panel Serial Number
- Chiller Serial Number
- YORK Order Number
- System Information
- Condenser and Evaporator Design Load Information
- Nameplate Information

The **OPERATIONS** screen permits definition of parameters pertaining to operation of the chiller. What is defined is whether the control of the chiller will be Local, Digital Remote, Analog Remote, Modem Remote or ISN Remote.

Programmable

- Control Source

The **HISTORY** screen allows the user to browse through the last ten faults; either safety or cycling shutdowns with the conditions, while the chiller is running or stopped. The faults are color coded for ease in determining the severity at a glance, recording the date, time and description. (See Display Messages for Color Code meanings.)

Display Only

- Last Normal Shutdown
- Last Fault While Running
- Last Ten Faults

Programmable:

- Print History
- Print All Histories

By pressing the **VIEW DETAILS** key you will move to the **HISTORY DETAILS** screen. From these screens you are able to see an on-screen printout of all the system parameters at the time of the selected shutdown.

Display Only:

- History Printout

Programmable:

- Page Up
- Page Down
- Print History

Also under the **HISTORY** screen is the **TRENDING** screen, accessible by the key marked the same. On this screen, up to six operator-selected parameters, selected from a list of over 140, can be plotted in an X/Y graph format. The graph can be customized to record points once every second up to once every hour. There are two types of charts that can be created: single screen, or continuous screen. The single screen collects data for one screen width (450 data points across the X-axis), then stops. The continuous screen keeps collecting the data, but the oldest data drops off the graph from left to right at the next data collection interval. For ease of identification, each plotted parameter, title and associated Y-axis labeling is color coordinated.

Display Only:

- This screen allows the user to view the graphical trending of the selected parameters and is a gateway to the graph setup screens.

Programmable:

- Start
- Stop
- y-axis
- x-axis

The **TREND SETUP** screen is used to configure the trending screen. The parameters to be trended are selected from the Trend Common Slots screen, accessed from the Slot Numbers button or the Master Slot Numbers List found in the Operating Manual. The interval at which all the parameters are sampled is selected under the Collection Interval button. The data point minimum and maximum values may be adjusted closer to increase viewing resolution.

Programmable:

- Chart Type (select *continuous* or *one screen*)
- Collection Interval
- Select
- Data Point Slot Number (1 - 6)
- Data Point Min (1 - 6)
- Data Point Max (1 - 6)

The **TREND COMMON SLOTS** screen displays the Master Slot Numbers List of the monitored parameters.

Display Only:

- Slot Numbers

Programmable:

- Page Up
- Page Down
- Print

DISPLAY MESSAGES

The Control Center continuously monitors the operating system, displaying and recording the cause of any shutdowns (Safety, Cycling or Normal). The condition of the chiller is displayed at the System Status line that contains a message describing the operating state of the chiller; whether it is stopped, running, starting or shutting down. A System Details Line displays Warning, Cycling, Safety, Start Inhibit and other messages that provide further details of the Status Bar messages. Messages are color-coded: Green – Normal Operations; Yellow – Warnings; Orange – Cycling Shutdowns; and Red – Safety Shutdowns to aid in identifying problems quickly.

Status messages include:

- System Ready To Start
- Cycling Shutdown – Auto Restart
- Safety Shutdown – Manual Restart
- Start Sequence Initiated

- System Run (with countdown timers)
- Start Inhibit
- Slide Valve Closing Before Shutdown
- System Lockout Delay

Run Messages include:

- Leaving Chilled Liquid Control
- Motor Pulldown Limit
- Motor – High Current Limit

Start Inhibit Messages include:

- Anti-Recycle XX min/sec.
- Slide Valve – Position >30%
- Motor Current >15% FLA
- LCSSS – High-Temperature Phase X - Stopped

Warning Messages include:

- Real Time Clock Failure
- Setpoint Override
- Condenser – High Pressure Limit
- Evaporator – Low Pressure Limit
- Freeze Threat From Operating Chiller
- Freeze Threat, Condenser Flow Switch Open
- Low Discharge Superheat Limit
- Low Discharge Superheat Detected
- Maximum Load – Load Limit
- Minimum Load – Load Limit
- Oil – Dirty Filter
- Oil – High Temperature
- Slide Valve Uncalibrated

Routine Shutdown Messages Include:

- Remote Stop
- Local Stop
- Place Compressor Switch In Run Position

Cycling Shutdown Messages Include:

- Multiunit Cycling – Contacts Open
- System Cycling – Contacts Open
- Control Panel – Power Failure
- Leaving Chilled Liquid – Low Temperature
- Leaving Chilled Liquid – Flow Switch Open
- Condenser – Flow Switch Open
- Motor Controller – Contacts Open
- Motor Controller – Loss of Current

- Power Fault
- Control Panel – Schedule

Solid State Starter Only (LCSSS)

- Initialization Failed
- Serial Communications
- Requesting Fault Data
- Stop Contacts Open
- Power Fault
- Low Phase (X) Temperature Sensor
- Run Signal
- Invalid Current Scale Selection
- Phase Locked Loop
- Low Supply Line Voltage
- High Supply Line Voltage
- Logic Board Processor
- Logic Board Power Supply
- Phase Loss

Safety Shutdown Messages include:

- Evaporator – Low Pressure
- Evaporator – Low Pressure – Smart Freeze
- Evaporator – Transducer or Leaving Liquid Probe
- Evaporator – Transducer or Temperature Sensor
- Condenser – High Pressure Contacts Open
- Condenser – High Pressure
- Condenser – Pressure Transducer Out of Range
- Auxiliary Safety – Contacts Closed
- Discharge – High Temperature
- Discharge – Low Temperature
- Oil – High Temperature
- Oil – Low Differential Pressure
- Oil – Low Differential Seal Pressure
- Oil or Condenser Transducer Error
- Oil – Clogged Filter
- Oil – High Pressure
- Oil – Separator – Low Level
- Control Panel – Power Failure
- Watchdog – Software Reboot

Solid State Starter Only (LCSSS)

- Shutdown – Requesting Fault Data . . .
- High Instantaneous Current
- High Phase (X) Heatsink Temperature – Running
- 105% Motor Current Overload
- Motor or Starter – Current Imbalance
- Open SCR
- Phase Rotation

Mechanical Specifications

STANDARD UNIT

General

The YORK Millennium YS Rotary Screw Chiller is completely factory-packaged, including evaporator (cooler), condenser, sub-cooler, oil separator, compressor, motor, lubrication system, control center and refrigerant isolation valves. The factory package consists of a "leaktight" design. All units ship as standard with a full charge of refrigerant and oil. Units can also be shipped in sections (optional) to accommodate job site requirements.

The services of a YORK factory-trained, field service representative are incurred to supervise or perform the final leak testing, charging, the initial start-up, and concurrent operator instructions.

Compressor

The Frick Rotary Twin Screw Compressor is engineered and constructed to meet the exact requirements of the industrial refrigeration market. It utilizes state-of-the-art technology to provide the most reliable and energy-efficient compressor available at all operating conditions. The compressor operates at 3750 RPM for 60 Hertz and 2975 RPM for 50 Hertz. The compressor housing is made of cast iron, precision-machined to provide minimal clearance for the rotors. Compressor housing has a design working pressure (DWP) of 300 PSIG (2068 kPa) minimum, and hydro-tested at 544 PSIG (3751 kPa).

The rotors are manufactured from forged steel and use asymmetric profiles. The compressor incorporates a complete anti-friction bearing design for reduced power and increased reliability. Four separate cylindrical roller bearings handle radial loads. Two 4-point angular contact ball bearings handle axial loads. Together, they maintain accurate rotor positioning at all pressure ratios, thereby minimizing blow-by and maintaining efficiency.

A check valve is installed in the compressor discharge housing (suction housing for S4 and S5 compressor) to prevent compressor rotor back spin because of system refrigerant pressure gradients during shutdown.

The open-drive compressor shaft seal consists of precision ceramic seal faces, metallic bellows, rotating member, PTFE 'C'-Ring static seal, and multi-port oil injection ring. The seal cavity is maintained at intermediate pressure with its oil discharged to the oil drain from the compressor. Combining intermediate pressure with direct oil injection provides cool, non-foaming lubricant to the seal assuring a longer lifespan.

Capacity Control

Capacity control is achieved by use of a slide valve which provides fully modulating capacity control from 100% to 10% of full load. The slide valve is actuated by oil pressure, controlled by external solenoid valves via the OptiView Control Center.

Oil Separator

The oil separator is a horizontal design without moving parts. Effective oil separation is achieved by gravity drop-out of oil from the refrigerant gas as velocity decreases upon entering the separator, and by mesh pads to provide final gas/oil separation before gas enters the condenser. The oil separator is designed for 345 PSIG (2378 kPa) design working pressure, tested at 517 PSIG (3565 kPa), and stamped in accordance with ASME Boiler and Pressure Vessel Code, Section VIII - Division 1. Each vessel has a refrigerant relief device(s) set at 300 PSIG (2068 kPa). In addition to the spring-loaded, re-seating-type relief valves sized for pressure vessel volume, each unit is equipped with a rupture disk. This rupture disk is able to relieve the entire pumping capacity of the compressor if electronic safeties fail, providing protection for property and personnel. This device is set for 345 PSIG (2378 kPa). Alternatively, the shell side may be designed to European Pressure Vessel Codes and stamped in accordance with A.D. Merkblätter or other European Pressure Vessel design code. When required by the refrigeration safety code, each vessel has a dual refrigerant relief device(s).

Lubrication

The main unit oil reservoir is located in the oil separator. The compressor also has an oil reservoir located at the rotor bearings to provide lubrication during start-up, coatdown, and in the event of a power failure. During operation, system pressure differential provides proper oil flow without the need of an auxiliary oil pump. This minimizes energy consumption.

The chiller is shipped with a 3 Micron absolute oil filter, ensuring a clean oil system and superior compressor life. An external, replaceable cartridge oil filter is supplied with manual isolation stop valves for ease of servicing. An optional dual oil filter housing with isolation valves is available on all units. This allows immediate switching from one filter to the other, eliminating downtime during filter changes. The off-line oil filter can be changed during chiller operation.

Mechanical Specifications (continued)

A 500 watt (115 volt - 1-phase - 60/50Hz) immersion oil heater is located in the oil separator reservoir, temperature actuated to efficiently remove refrigerant from the oil. Oil heater power supply is factory wired from the control panel. A factory-piped refrigerant-cooled oil cooler is provided as standard. No auxiliary water piping is required. An oil eductor automatically removes oil which may have migrated to the evaporator and returns it to the compressor.

MOTOR DRIVELINE

The compressor motor is an open drip-proof, squirrel cage, induction type constructed to YORK design specifications. 60 Hertz motors operate at 3750 RPM; 50 Hertz motors operate at 2975 RPM. The open motor is provided with a D-Flange and is factory-mounted to a cast-iron adaptor mounted on the compressor. This unique design allows the motor to be rigidly coupled to the compressor to provide factory alignment of motor and compressor shafts.

Motor drive shaft is directly connected to the compressor shaft with a flexible disc coupling. Coupling has all metal construction with no wearing parts to assure long life. Additionally, no lubrication is required – providing low maintenance.

For units utilizing remote electro-mechanical starters, a large steel terminal box with gasketed front access cover is provided for field connected conduit. There are six terminals (three for medium voltage) brought through the motor casing into the terminal box. Jumpers are furnished for three-lead type of starting. Motor terminal lugs are not furnished. Overload/overcurrent transformers are furnished with all units. For units furnished with factory-packaged Solid State Starters, refer to the Accessories and Modifications section (page 17).

HEAT EXCHANGERS

Shells

Evaporator and condenser shells are fabricated from rolled carbon steel plates with fusion welded seams. Carbon steel tube sheets, drilled and reamed to accommodate the tubes, are welded to the end of each shell. Intermediate tube supports are fabricated from carbon steel plates, drilled and reamed to eliminate sharp edges, and spaced no more than four feet apart. The refrigerant side of each shell is designed, tested, and stamped in accordance with ASME Boiler and Pressure Vessel Code, Section VIII – Division I, or other pressure vessel code as appropriate.

Tubes

Heat exchanger tubes are state-of-the-art, high efficiency,

externally and internally enhanced type to provide optimum performance. Tubes in both the evaporator and condenser are 3/4" O.D. copper alloy and utilize the "skip-fin" design, providing a smooth internal and external surface at each intermediate tube support. This provides extra wall thickness (up to twice as thick) and non-work hardened copper at the support location, extending the life of the heat exchangers. Each tube is roller expanded into the tube sheets providing a leak-proof seal, and is individually replaceable.

Evaporator

The evaporator is a shell and tube, flooded type heat exchanger. A distributor trough provides uniform distribution of refrigerant over the entire shell length to yield optimum heat transfer. A suction baffle or aluminum mesh eliminators are located above the tube bundle to prevent liquid refrigerant carryover into the compressor. A 1-1/2" liquid level sight glass is conveniently located on the side of the shell to aid in determining proper refrigerant charge. The evaporator shell contains a dual refrigerant relief valve arrangement set at 180 PSIG (1241 kPa); or single-relief valve arrangement, if the chiller is supplied with the optional refrigerant isolation valves. A 1" refrigerant charging valve is provided.

Condenser

The condenser is a shell and tube type, with a discharge gas baffle to prevent direct high velocity impingement on the tubes. The baffle is also used to distribute the refrigerant gas flow properly for most efficient heat transfer. An integral sub-cooler is located at the bottom of the condenser shell providing highly effective liquid refrigerant subcooling to provide the highest cycle efficiency. The condenser contains dual refrigerant relief valves set at 235 PSIG (1620 kPa).

Water Boxes

The removable water boxes are fabricated of steel. The design working pressure is 150 PSIG (1034 kPa) and the boxes are tested at 225 PSIG (1551 kPa). Integral steel water baffles are located and welded within the water box to provide the required pass arrangements. Stub-out water nozzle connections with Victaulic grooves are welded to the water boxes. These nozzle connections are suitable for Victaulic couplings, welding or flanges, and are capped for shipment. Plugged 3/4" drain and vent connections are provided in each water box.

REFRIGERANT FLOW CONTROL

The YS Chiller is equipped with a refrigerant metering device consisting of a fixed orifice and bypass solenoid valve, which automatically adjusts to all real-world operating conditions. This control ensures proper refrigerant

flow to the evaporator over a wide range of operating conditions, including thermal storage applications and chilled water reset. Valve operation is programmable and can be customized for a specific application via the control panel keyboard.

REFRIGERANT ISOLATION

The condenser shell serves as a refrigerant receiver to store the system charge during servicing. Manually operated isolation valves are located at the inlet and outlet of the condenser. Valves are also provided to facilitate removal of the refrigerant from the system when necessary.

OPTIVIEW CONTROL CENTER

General

The chiller is controlled by a stand-alone microprocessor-based control center. The chiller control panel provides control of chiller operation and monitoring of chiller sensors, actuators, relays and switches.

Control Panel

The control panel includes a 10.4 inch diagonal color liquid crystal display (LCD) surrounded by "soft" keys, which are redefined based on the screen displayed at that time, mounted in the middle of a keypad interface and installed in a locked enclosure. The screen details all operations and parameters, using a graphical representation of the chiller and its major components. Panel verbiage is available in other languages as an option with English always available. Data can be displayed in either English or Metric units. Smart Freeze Point Protection will run the chiller at 36°F (2.22°C) leaving chilled water temperature and not experience nuisance trips on low water temperature. The sophisticated program and sensor monitors the chiller water temperature to prevent freeze-up. When needed, Hot Gas Bypass is available as an option. The panel displays countdown timer messages so the operator knows when functions are starting and stopping. Every programmable point has a pop-up screen with the ranges included, so the chiller can not be programmed to operate outside of its design limits.

The control panel includes a thermal ice storage control mode which enhances system performance during ice building operation when compared to standard cooling logic. In thermal storage control mode, the chiller will operate at 100% load until the setpoint shutdown temperature is reached. To add greater operating flexibility and eliminate unnecessary chiller cycling, two different Low Water (Liquid) Temperature Restart Thresholds are programmable, one for the ice mode and one for the standard cooling mode. The chiller has the capability to re-

main in the standard control mode for temperatures between 20°F to 70°F (-6.7°C to 21.1°C) for applications involving a process cooling duty that requires leaving chilled liquid temperature setpoint control.

The chiller control panel also provides:

1. System operating information including:
 - Return and Leaving Chilled Water Temperature
 - Return and Leaving Condenser Water Temperature
 - Evaporator and Condenser Saturation Temperature
 - Oil Pressure at Compressor and Oil Filter Differential
 - Percent Motor Current
 - Evaporator and Condenser Saturation Temperature
 - Compressor Discharge Temperature
 - Oil Temperature
 - Percent Slide Valve Position
 - Operating Hours
 - Number of Unit Starts
2. Digital Programming of Setpoints Through The Universal Keypad Including:
 - Leaving Chilled Water Temperature
 - Percent Current Limit
 - Pull-Down Demand Limiting
 - Six-Week Schedule For Starting and Stopping The Chiller, Pumps and Tower
 - Remote Reset Temperature Range
3. Status Messages Indicating:
 - System Ready To Start
 - System Running
 - System Coastdown
 - System Safety Shutdown – Manual Restart
 - System Cycling Shutdown – Auto Restart
 - System Prelube
 - Start Inhibit
4. The text displayed within the system status and system details field is displayed as a color-coded message to indicate severity: red for safety fault; orange for cycling faults; yellow for warnings; and green for normal messages.
5. Safety shutdowns are enunciated through the display and the status bar, and consist of system status, system details, day, time, cause of shutdown, and type of restart required. Safety shutdowns with a fixed speed drive include:
 - Evaporator – Low Pressure
 - Evaporator – Low Pressure - Smart Freeze
 - Evaporator – Transducer or Leaving Liquid Probe

Mechanical Specifications (continued)

- Evaporator – Transducer or Temperature Sensor
 - Condenser – High Pressure Contacts Open
 - Condenser – High Pressure
 - Condenser – Pressure Transducer Out Of Range
 - Auxiliary Safety – Contacts Closed
 - Discharge – High Temperature
 - Discharge – Low Temperature
 - Oil – High Temperature
 - Oil – Low Differential Pressure
 - Oil – Low Differential Seal Pressure
 - Oil Or Condenser Transducer Error
 - Oil – Clogged Filter
 - Oil – High Pressure
 - Oil – Separator – Low Level
 - Control Panel – Power Failure
 - Watchdog – Software Reboot
- 5.1 Safety shutdowns with a Solid State Starter (LCSSS) include:
- Shutdown - Requesting Fault Data...
 - High Instantaneous Current
 - High Phase (X) Heatsink Temperature - Running
 - 105% Motor Current Overload
 - Motor Or Starter – Current Imbalance
 - Phase (X) Shorted SCR
 - Open SCR
 - Phase Rotation
6. Cycling shutdowns enunciated through the display and the status bar, and consists of system status, system details, day, time, cause of shutdown, and type of restart required.
- Cycling shutdowns with a fixed speed drive include:
- Multiunit Cycling - Contacts Open
 - System Cycling - Contacts Open
 - Control Panel - Power Failure
 - Leaving Chilled Liquid – Low Temperature
 - Leaving Chilled Liquid – Flow Switch Open
 - Condenser - Flow Switch Open
 - Motor Controller – Contacts Open
 - Motor Controller – Loss Of Current
 - Power Fault
 - Control Panel – Schedule
- 6.1 Cycling shutdowns with a Solid State Starter (LCSSS) include:
- Initialization Failed
 - Serial Communications
 - Requesting Fault Data
 - Stop Contacts Open
 - Power Fault
 - Low Phase (X) Temperature Sensor
 - Run Signal
 - Invalid Current Scale Selection
 - Phase Locked Loop
 - Low Supply Line Voltage
 - High Supply Line Voltage
 - Logic Board Processor
 - Logic Board Power Supply
 - Phase Loss
7. Security access to prevent unauthorized change of setpoints, to permit local or remote control of the chiller, and to allow manual operation of the prerotation vanes and oil pump. Access is through ID and password recognition, which is defined by three different levels of user competence: view, operator, and service.
8. Trending data with the ability to customize points of once every second to once every hour. The panel will trend up to 6 different parameters from a list of over 140, without the need of an external monitoring system.
9. The operating program is stored in non-volatile memory (EPROM) to eliminate reprogramming the chiller due to AC power failure or battery discharge. Programmed setpoints are retained in lithium battery-backed RTC memory for a minimum of 11 years with power removed from the system.
10. A fused connection through a transformer in the compressor motor starter to provide individual over-current protected power for all controls.
11. A numbered terminal strip for all required field interlock wiring.
12. An RS-232 port to output all system operating data, shutdown/cycling message, and a record of the last 10 cycling or safety shutdowns to a field-supplied printer. Data logs to a printer at a set programmable interval. This data can be preprogrammed to print from 1 minute to 1 day.
13. The capability to interface with a building automation system to provide:
- remote chiller start and stop
 - remote leaving chilled liquid temperature adjust
 - remote current limit setpoint adjust
 - remote ready to start contacts
 - safety shutdown contacts
 - cycling shutdown contacts
 - run contacts

CODES AND STANDARDS

- ASME Boiler and Pressure Vessel Code – Section VIII Division 1.
- ARI Standard 550/590
- c/U.L. – Underwriters Laboratory
- ASHRAE 15 – Safety Code for Mechanical Refrigeration
- ASHRAE Guideline 3 – Reducing Emission of Halogenated Refrigerants in Refrigeration and Air-Conditioning Equipment and Systems
- NEC – National Electrical Code
- OSHA – Occupational Safety and Health Act
- A.D. Merkblatter

ISOLATION MOUNTING

The unit is provided with four vibration isolation mounts consisting of 1" (25.4 mm) thick neoprene isolation pads for field mounting under the steel mounting pads located on the tube sheets.

REFRIGERANT CONTAINMENT

The standard unit has been designed as a complete and compact factory packaged chiller. As such, it has minimum joints from which refrigerant can leak. The entire assembly has been thoroughly leak tested at the factory prior to shipment. The YORK chiller includes service valves conveniently located to facilitate transfer of refrigerant to a remote refrigerant storage/recycling system. Optional condenser isolation valves permit storage of the charge in the condenser.

PAINT

Exterior surfaces are protected with one coat of Caribbean blue, durable alkyd-modified, vinyl enamel, machinery paint.

SHIPMENT

Protective covering is furnished on the motor, Control Center and unit-mounted controls. Water nozzles are capped with fitted plastic enclosures.

Accessories and Modifications

SOLID STATE STARTER

The Solid State Starter is a reduced voltage starter that controls and maintains a constant current flow to the motor during startup. It is compact and mounted on the chiller at the motor terminals. Power and control wiring is factory supplied. Available for 200-600 volts, the starter enclosure is NEMA-1 with a hinged access door with lock and key. Electrical lugs for incoming power wiring are provided.

Standard features include: digital readout at the OptiView Control Center of the following:

Display Only:

- 3-phase voltage A, B, C
- 3-phase current A, B, C
- Input power (kW)
- kW Hours
- Starter Model
- Motor Run (LED)
- Motor Current % Full Load Amps

- Current Limit Setpoints
- Pulldown Demand Time Left

Programmable:

- Local Motor Current Limit
- Pulldown Demand Limit
- Pulldown Demand Time

Other features include: low line voltage; 115-volt control transformer; three-leg sensing overloads; phase rotation and single-phase failure protection; high temperature safety protection; motor current imbalance and undervoltage safeties; open and close SCR protection; momentary power interruption protection. The LCSSS is cooled by a closed-loop, fresh water circuit consisting of a water-to-water heat exchanger and 1/25 HP circulating pump. All interconnecting water piping is factory installed and rated for 150 PSIG working pressure. **Optional** unit-mounted circuit breaker includes ground fault protection and provides 65,000 amp short-circuit withstand rating in accordance with UL Standard 508. A non-fused disconnect switch is also available. Both options are padlockable.

Accessories and Modifications (continued)

BAS REMOTE CONTROL

A communication interface permitting complete exchange of chiller data with any BAS system is available with optional ISN translator. ISN translator also allows BAS system to issue commands to the chiller to control its operation. ISN translators come in two models, controlling up to four chillers and eight chillers respectively.

FACTORY INSULATION OF COOLER

Factory-applied thermal insulation of the flexible, closed-cell plastic type, 3/4" (19mm) thick is attached with vapor-proof cement to the cooler shell, flow chamber, cooler tube sheets, suction connection, and (as necessary) to the auxiliary tubing. Not included is the insulation of water boxes and nozzles. This insulation will normally prevent condensation in environments with relative humidities up to 75% and dry bulb temperatures ranging from 50° to 90°F (10° to 32°C). 1-1/2" (38mm) thick insulation is also available for relative humidities up to 90% and dry bulb temperatures ranging from 50° to 90°F (10° to 32°C).

WATER FLANGES

Four 150 lb. ANSI raised-face flanges, for condenser and cooler water connections, are factory welded to water nozzles. Companion flanges, bolts, nuts and gaskets are not included.

SPRING ISOLATION MOUNTING

Spring Isolation mounting is available instead of standard isolation mounting pads when desired. Four level-adjusting/spring-type vibration isolator assemblies with non-skid pads are provided with mounting brackets for field installation. Isolators are designed for one-inch (25.4 mm) deflection.

WATER FLOW SWITCHES

Paddle-type, vapor-proof water flow switches suitable for 150 psig (1034 KPa) DWP for chilled and condenser water circuits. Switch for 115V-1-50/60 Hz service. A chilled water flow switch is required. Condenser water flow switch is optional.

SEQUENCE CONTROL KIT

For two, three or four units with chilled water circuits connected in series or parallel, the kit consists of return water thermostat, lead-lag selector switch for sequence starting, and time delay relay, with NEMA-1 enclosures, designed for 115V-1-50/60 Hz.

STARTER – FIELD INSTALLED

A field installed, electro-mechanical compressor motor starter is available, selected for proper size and type for job requirements and in accordance with YORK Engineering Standard R-1079 for Starters.

MARINE WATER BOXES

Marine water boxes allow service access for cleaning of the heat exchanger tubes without the need to break the water piping. Bolted-on covers are arranged for convenient access. Victaulic nozzle connections are standard; flanges are optional. Marine water boxes are available for condenser and/or evaporator.

KNOCK-DOWN SHIPMENT

The chiller can be shipped knocked-down into major assemblies (cooler, condenser, driveline, etc.) as required to rig into tight spaces. This is particularly convenient for existing buildings where equipment room access does not allow rigging a factory packaged chiller.

REFRIGERANT STORAGE/RECYCLING SYSTEM

A refrigerant storage/recycling system is a self-contained package consisting of a refrigerant compressor with oil separator, storage receiver, water-cooled condenser, filter drier and necessary valves and hoses to remove, replace and distill refrigerant. All necessary controls and safety devices are a permanent part of the system. Typically not required if unit isolation valves are provided.

Unit Components

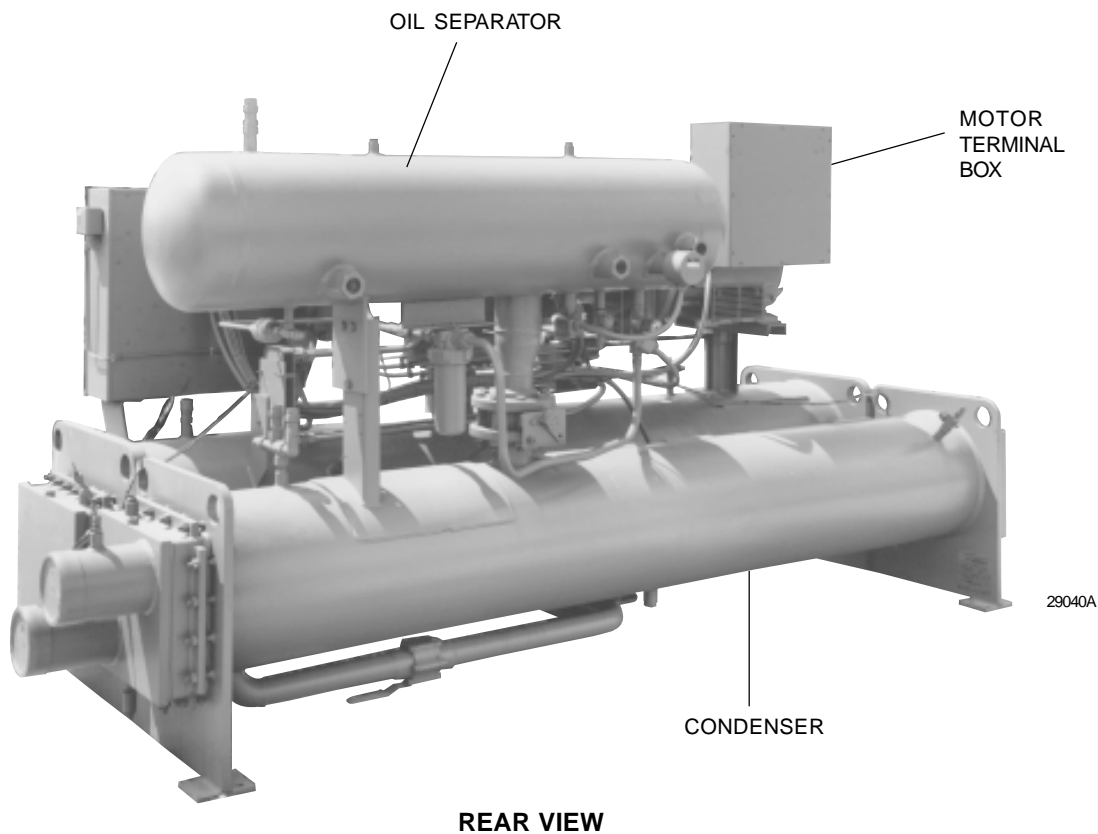
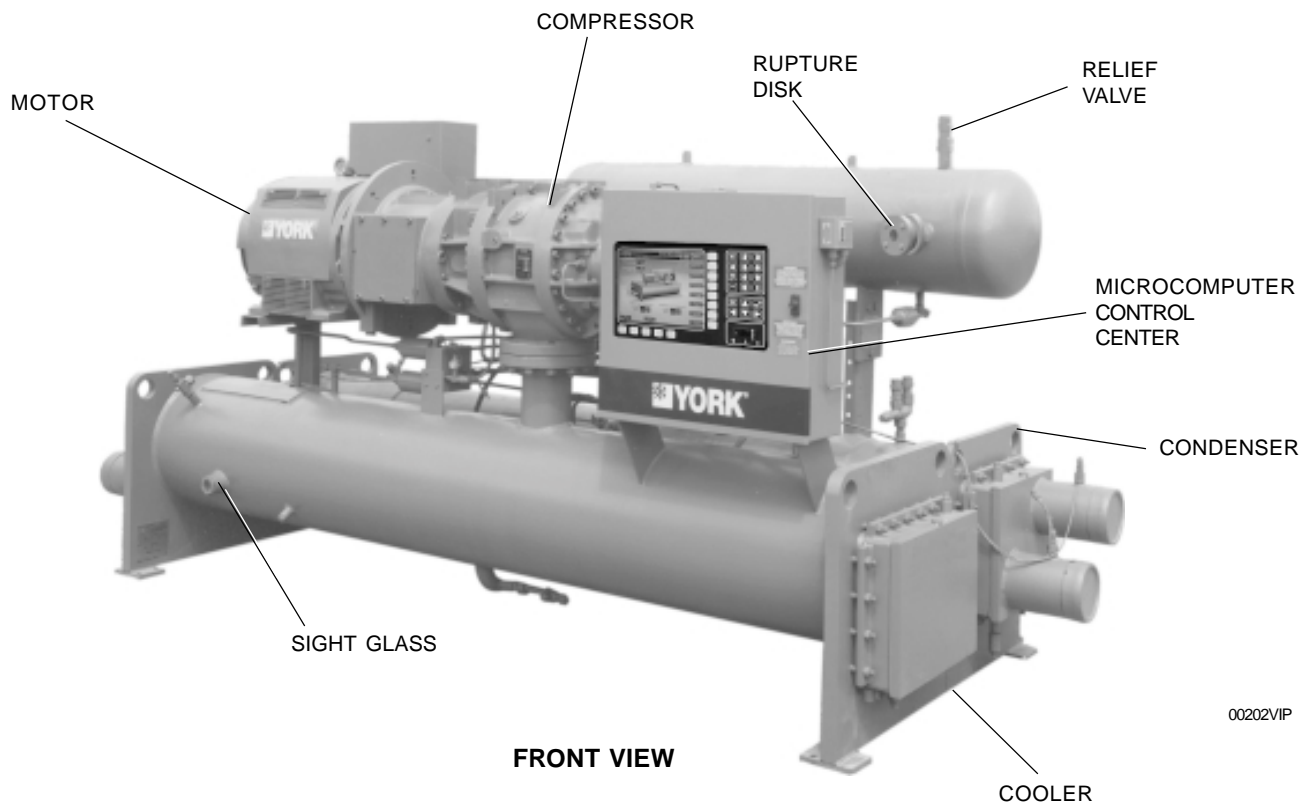

Application Data

The following is a user's guide in the application and installation of *Millennium Chillers*, and will ensure the reliability and trouble-free life for which this equipment was designed. While this guide is directed towards normal, water-chilling applications, the YORK sales representatives can provide complete recommendations on other types of applications.

Location

Millennium Chillers are virtually vibration-free and generally can be located at any level in a building where the construction will support the total system operating weight.

The unit site must be a floor, mounting pad or foundation which is level within 1/4" (6.4 mm) and capable of supporting the operating weight of the chiller.

Sufficient clearance to permit normal service and maintenance work should be provided all around and above the unit. Additional space should be provided at one end of the unit to permit cleaning of cooler and condenser tubes as required. A doorway or other properly located opening may be used.

The chiller should be installed in an indoor location where temperatures range from 40°F to 110°F (4.4°C to 43.3°C).

Water Circuits

Flow Rate – For normal water chilling duty, cooler flow rates are permitted at water velocity levels in the heat exchangers tubes of between 3 ft./second and 12 ft./second (0.91 m/s and 3.66 m/s). Condenser flow rates are permitted between 3.33 ft./sec. and 12 ft./sec. (1.01 m/s and 3.66 m/s). Variable flow applications are possible, and initial chiller selections should be made accordingly

TABLE 1 – WATER FLOW RATE LIMITS – GPM (L/s)

SHELL CODE	PASS	COOLER		CONDENSER	
		MINIMUM	MAXIMUM	MINIMUM	MAXIMUM
BA	1	308 (19.4)	1173 (74.0)	399 (25.2)	1435 (90.5)
	2	147 (9.3)	586 (37.0)	209 (13.2)	751 (47.4)
	3	97 (6.1)	387 (24.4)	—	—
BB	1	412 (25.9)	1572 (99.2)	510 (32.2)	1830 (115.5)
	2	197 (12.4)	786 (49.6)	264 (16.7)	948 (59.8)
	3	130 (8.2)	516 (32.6)	—	—
CA	1	535 (33.8)	2041 (128.8)	677 (42.7)	2438 (153.8)
	2	256 (16.2)	1020 (64.4)	355 (22.4)	1277 (80.6)
	3	171 (10.8)	680 (42.9)	—	—
CB	1	700 (44.2)	2675 (168.8)	880 (55.5)	3164 (80.6)
	2	335 (21.1)	1337 (84.4)	455 (28.7)	1639 (103.4)
	3	223 (14.1)	891 (56.2)	—	—
DA	1	664 (41.9)	2534 (159.9)	1215 (76.7)	4376 (276.1)
	2	317 (20.0)	1267 (79.9)	630 (39.8)	2269 (143.2)
	3	212 (13.4)	844 (53.3)	—	—
DB	1	943 (59.5)	3602 (227.3)	1595 (100.6)	5740 (362.2)
	2	451 (28.5)	1793 (113.1)	820 (51.7)	2950 (186.1)
	3	301 (19.0)	1195 (75.4)	—	—
DC	1	1257 (79.3)	4810 (303.5)	—	—
	2	602 (38.0)	2405 (151.8)	—	—
	3	399 (25.2)	1595 (100.6)	—	—
EA	1	637 (40.2)	2546 (160.6)	1223 (77.2)	4406 (270.8)
	2	317 (20.0)	1267 (79.7)	639 (40.3)	2300 (145.1)
	3	212 (13.4)	844 (53.3)	—	—
EB	1	904 (57.0)	3613 (228.0)	1602 (101.1)	5770 (364.1)
	2	452 (28.5)	1805 (113.9)	828 (55.2)	2982 (188.2)
	3	301 (19.0)	1196 (75.5)	—	—
EC	1	1203 (75.9)	4810 (303.5)	—	—
	2	602 (38.0)	2405 (151.8)	—	—
	3	399 (25.2)	1595 (100.6)	—	—
FA	1	1203 (75.9)	4810 (303.5)	2019 (127.4)	7267 (458.5)
	2	602 (38.0)	2405 (151.8)	1043 (65.8)	3755 (236.9)
	3	399 (25.2)	1595 (100.6)	—	—
FB	1	1605 (101.3)	6418 (405.0)	2726 (172)	9822 (619.8)
	2	802 (50.6)	3202 (202.0)	1397 (88.2)	5030 (317.4)
	3	534 (33.7)	2135 (134.7)	—	—
FC	1	2136 (134.8)	8541 (538.9)	—	—
	2	1068 (67.4)	4270 (269.4)	—	—
	3	710 (44.8)	2839 (179.1)	—	—

to permit proper range of flow while maintaining the minimum velocity noted above. Variable flow in the condenser is not recommended, as it generally raises the energy consumption of the system by keeping the condenser pressure high in the chiller. Additionally, the rate of fouling in the condenser will increase at lower water velocities associated with variable flow, raising system maintenance costs. Cooling towers typically have narrow ranges of operation with respect to flow rates, and will be more effective with full design flow. Ref. Table 1 for flow limits.

Temperature Ranges – For normal water chilling duty, leaving chilled water temperatures may be selected between 38°F (3.3°C) [36°F (2.2°C) with Smart Freeze enabled) and 70°F (21.1°C) for water temperature ranges between 3°F and 30°F (1.7°C and 16.7°C).

Water Quality – The practical and economical application of liquid chillers requires that the quality of the water supply for the condenser and cooler be analyzed by a water treatment specialist. Water quality may affect the performance of any chiller through corrosion, deposition of heat-resistant scale, or sedimentation or organic growth. These will degrade chiller performance and increase operating and maintenance costs. Normally, performance may be maintained by corrective water treatment and periodic cleaning of tubes. If water conditions exist which cannot be corrected by proper water treatment, it may be necessary to provide a larger allowance for fouling, and/or to specify special materials of construction.

General Piping – All chilled water and condenser water piping should be designed and installed in accordance with accepted piping practice. Chilled water and condenser water pumps should be located to discharge through the chiller to assure positive pressure and flow through the unit. Piping should include offsets to provide flexibility and should be arranged to prevent drainage of water from the cooler and condenser when the pumps are shut off. Piping should be adequately supported and braced independently of the chiller to avoid the imposition of strain on chiller components. Hangers must allow for alignment of the pipe. Isolators in the piping and in the hangers are highly desirable in achieving sound and vibration control.

Convenience Considerations – To facilitate the performance of routine maintenance work, some or all of the following steps may be taken by the purchaser. Cooler and condenser water boxes are equipped with plugged vent and drain connections. If desired, vent and drain valves may be installed with or without piping to an open drain. Pressure gauges with stop cocks, and stop valves, may be installed in the inlets and outlets of the condenser and chilled water line as close as possible to the chiller. An overhead mono-rail or beam may be used to facilitate servicing.

Connections – The standard chiller is designed for 150 psig (1034 kPa) design working pressure in both the chilled water and condenser water circuits. The connections (water nozzles) to these circuits are furnished with grooves for Victaulic couplings. Piping should be arranged for ease of disassembly at the unit for tube cleaning. All water piping should be thoroughly cleaned of all dirt and debris before final connections are made to the chiller.

Chilled Water – A flow switch must be installed in the chilled water line of every unit. The switch must be located in the horizontal piping close to the unit, where the straight horizontal runs on each side of the flow switch are at least five pipe diameters in length. The switch must be electrically connected to the chilled water interlock position in the unit control center. A water strainer of maximum 1/8" (3.2 mm) perforated holes must be field-installed in the chilled water inlet line as close as possible to the chiller. If located close enough to the chiller, the chilled water pump may be protected by the same strainer. The flow switch and strainer assure chilled water flow during unit operation. The loss or severe reduction of water flow could seriously impair the chiller performance or even result in tube freezeup.

Condenser Water – The chiller is engineered for maximum efficiency at both design and part-load operation by taking advantage of the colder cooling tower water temperatures which naturally occur during the winter months. Appreciable power savings are realized from these reduced heads.

The minimum entering condenser water temperature for other full and part load conditions is provided by the following equation:

$$\text{For R-22; } \text{Min ECWT} = \text{LCHWT} + 11 + [(\% \text{ load}/100) \times (15 - \text{full load condenser water } \Delta T)]$$

$$\text{For R-134a; } \text{Min ECWT} = \text{LCHWT} + 16 + [(\% \text{ load}/100) \times (10 - \text{full load condenser water } \Delta T)]$$

Where: ECWT = entering condenser water temperature
LCHWT = leaving chilled water temperature

MULTIPLE UNITS

Selection – Many applications require multiple units to meet the total capacity requirements as well as to provide flexibility and some degree of protection against equipment shutdown. There are several common unit arrangements for this type of application. The *Millennium* Chiller has been designed to be readily adapted to the requirements of these various arrangements.

Parallel Arrangement (Refer to Fig. 1) – Chillers may be applied in multiples with chilled and condenser water circuits connected in parallel between the units. Fig. 1

Application Data

represents a parallel arrangement with two chillers. Parallel chiller arrangements may consist of equally or unequally sized units. When multiple units are in operation, they will load and unload at equal percentages of design full load for the chiller.

Depending on the number of units and operating characteristics of the units, loading and unloading schemes should be designed to optimize the overall efficiency of the chiller plant. It is recommended to use an evaporator by-pass piping arrangement to bypass fluid around evaporator of any unit which has cycled off at reduced load conditions. It is also recommended to alternate the chiller cycling order to equalize chiller starts and run hours.

Series Arrangement (Refer to Fig. 2) – The chillers may be applied in pairs with chilled water circuits connected in series and condenser water circuits connected in parallel. All of the chilled water flows through both coolers with each unit handling approximately one-half of the total load. When the load decreases to a customer selected load value, one of the units will be shut down by a sequence control. Since all water is flowing through the operating unit, that unit will cool the water to the desired temperature.

BRINE APPLICATIONS

The YS Screw Chiller, utilizing the Frick Refrigeration compressor, is a good match for the high head requirements of low temperature brine applications. This is particularly true of thermal ice storage systems, typically requiring 22°F (–5.6°C) to 24°F (–4.4°C) leaving brine temperatures. This performance is enhanced with the standard thermal storage control mode described on page 6. Particular attention must be paid to the application of two or more chillers with evaporators in parallel or series when

the brine temperature is below 32°F (0°C). The brine **MUST NOT** flow through the evaporator of the idle chiller, because it can cause the condenser water to freeze. A bypass or other type of arrangement is required that shuts off flow to the idle evaporator. When units are applied in series with lead/lag capability, the units should be identical.

REFRIGERANT RELIEF PIPING

Each chiller is equipped with pressure relief devices. The purpose of the relief devices is to quickly relieve excess pressure of the refrigerant charge to atmosphere, as a safety precaution in the event of an emergency such as a fire. They are set to relieve at an internal pressure of 300 psig (2069 KPa) and are located on the condenser, cooler and oil separator; and are provided in accordance with ASHRAE 15 Safety Code and ASME or applicable pressure vessel code. When required and designated on the order form, the relief devices will satisfy the European requirements: (example VBG20). Under these circumstances the relief devices may be relief valves, overflow valves or type tested Safety Pressure switches or a combination of these devices.

In addition to the spring-loaded, re-seating-type relief valves that are sized for pressure vessel volume, each unit is equipped with a rupture disk. This rupture disk is able to relieve the entire pumping capacity of the compressor if electronic safeties fail, providing protection for property and personnel. This device is set for 345 psig (2379 KPa) [45 psig above the re-seating relief valves set at 300 psig (2069 KPa)].

Sized to the requirements of applicable codes, a vent line must run from the relief device to the outside of the building. This refrigerant relief piping must include a cleanable, vertical-leg dirt trap to catch vent-stack condensation. Vent piping must be arranged to avoid imposing a strain on the relief connections and should include one flexible connection.

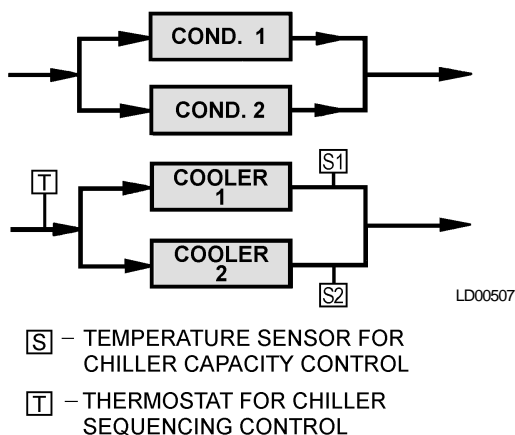

**FIG. 1 – PARALLEL COOLERS
PARALLEL CONDENSERS**

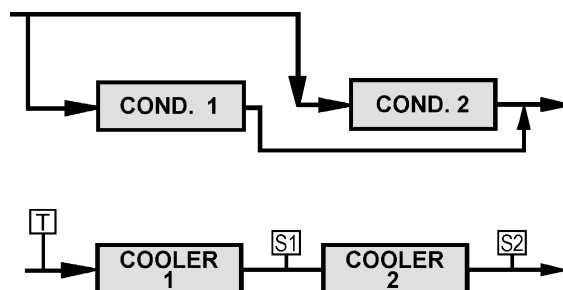

**FIG. 2 – SERIES COOLERS
PARALLEL CONDENSERS**

SOUND AND VIBRATION CONSIDERATIONS

A *Millennium* chiller is not a source of objectionable sound and vibration in normal air conditioning applications. Neoprene isolation mounts are furnished as standard with each unit. Optional level-adjusting spring isolator assemblies designed for 1" static deflection are available.

Millennium chiller sound pressure level ratings will be furnished upon request.

Control of sound and vibration transmission must be taken into account in the equipment room construction as well as in the selection and installation of the equipment.

THERMAL INSULATION

No appreciable operating economy can be achieved by thermally insulating the chiller. However, the chiller's cold surfaces should be insulated with a vapor barrier insulation sufficient to prevent condensation. A chiller can be factory insulated with 3/4" (19mm) or 1-1/2" (38mm) thick insulation, as an option. This insulation will normally prevent condensation in environments with dry bulb temperatures of 50°F to 90°F (10°C to 32°C) and relative humidities up to 75% [3/4" (19mm) thickness] or 90% [1-1/2" (38mm) thickness]. The insulation is painted and the surface is flexible and reasonably resistant to wear. It is intended for a chiller installed indoors and, therefore, no protective covering of the insulation is usually required. If insulation is applied to the water boxes at the job site, it must be removable to permit access to the tubes for routine maintenance.

TABLE 2 – MOTOR VOLTAGE VARIATIONS

FREQ.	RATED VOLTAGE	NAMEPLATE VOLTAGE	OPERATING VOLTAGE	
			MIN.	MAX.
60 HZ	200	200/208	180	220
	230	220/240	208	254
	380	380	342	415
	416	416	375	457
	460	440/460/480	414	508
	575	575/600	520	635
	2300	2300	2070	2530
	3300	3300	2970	3630
	4000	4000/4160	3600	4576
50 HZ	346	346	311	381
	380	380/400	342	423
	415	415	374	440
	3300	3300	2970	3630

VENTILATION

The ASHRAE Standard 15 Safety Code for Mechanical Refrigeration requires that all machinery rooms be vented to the outdoors utilizing mechanical ventilation by one or more power-driven fans. This standard, plus National Fire Protection Association Standard 90A, state, local and other related codes should be reviewed for specific requirements. Since the *Millennium* chiller motor is air-cooled, ventilation should allow for the removal of heat from the motor.

In addition, the ASHRAE Standard 15 requires a refrigerant vapor detector to be employed for all refrigerants. It is to be located in area where refrigerant from a leak would be likely to concentrate. An alarm is to be activated and the mechanical ventilation started at a value no greater than the TLV (Threshold Limit Value) of the refrigerant.

ELECTRICAL CONSIDERATIONS

Motor Voltage – Low voltage motors (200 - 600 volts) are furnished with six leads. Medium voltage (2300 - 4160 volts) motors have three leads. Motor circuit conductor size must be in accordance with the National Electrical Code (NEC), or other applicable codes, for the motor full-load amperes (FLA). Flexible conduit should be used for the last several feet to the chiller in order to provide vibration isolation. Table 2 lists the allowable variation in voltage supplied to the chiller motor. The unit nameplate is stamped with the specific motor voltage and frequency for the appropriate motor.

Starters – The chiller is available with a factory-mounted and wired YORK Solid State Starter for 200 - 600 volt applications. Other types of remote mounted starters are available. These electro-mechanical starters must be furnished in accordance with YORK Standard R-1079 Specification. This will ensure that starter components, controls, circuits, and terminal markings will be suitable for required overall system performance.

Controls – A 115 volt, single phase, 60 or 50 Hertz (4.5 kVa) power supply must be furnished to the chiller from a separate, fused disconnect or from a control transformer included as an option with electro-mechanical starters. No field control wiring is required, when the YORK SSS is supplied.

Copper Conductors – *Only copper conductors should be connected to compressor motors and starters.* Aluminum conductors have proven to be unsatisfactory when connected to copper lugs. Aluminum oxide and the difference in thermal conductivity between copper and aluminum cannot guarantee the required tight connection over a long period of time.

Power Factor Correction Capacitors – Capacitors can be applied to a chiller for the purpose of power factor

Application Data

correction. For remote-Mounted Electro-Mechanical Starters, the capacitors should be located on the load side of the starter. For YORK SSS, the capacitors must be located on the line side of the starter. The capacitors must be sized and installed to meet the National Electrical Code (NEC) and be verified by YORK.

Ampacity on Load Side of Starter – Electrical power wire size to the chiller is based on the minimum unit ampacity. For YORK SSS, this wiring is done at the factory. For remote starters, the National Electrical Code defines the calculation of ampacity, as summarized below. More specific information on actual amperage ratings will be supplied with the submittal drawings.

- Six-lead type of starting (Star-Delta)

Minimum circuit ampacity per conductor (1 of 6):
Ampacity = .721 x compressor motor amps.

- Three-lead type of starting
(Across-the-Line, Autotransformer and Primary Reactor)

Minimum circuit ampacity per conductor (1 of 3):
Ampacity = 1.25 x compressor motor amps.

Ampacity on Line Side of Starter –

The only additional load on the circuit for the chiller would be the control transformer, unless it is supplied by a separate source.

$$\text{Min. Circuit Ampacity} = \frac{125\% \text{ of compr. motor amps}}{\quad} + \frac{\text{FLA of all other loads on the circuit}}{\quad}$$

Branch Circuit Overcurrent Protection – The branch circuit overcurrent protection device(s) should be a time-delay type, with a minimum rating equal to the next standard fuse/breaker rating above the calculated value. It is calculated taking into account the compressor motor amps and may also include control transformer. Refer to submittal drawings for the specific calculations for each application.

MOTOR ELECTRICAL DATA

The smallest motor available which equals or exceeds the Input power (kW) from the chiller rating program is selected from Tables 3 and 4. The full load amperes (FLA) listed in the tables are maximum values and correspond to the maximum motor kW listed. When the Input power (kW) is less than maximum motor kW, the FLA should be reduced using the following equation:

$$\text{FLA} = \frac{\text{Motor kW}}{\text{Max. Motor kW}} \times \text{Max. Motor FLA}$$

The benefit from the FLA correction is the possible use of smaller power wiring and/or starter size.

The locked rotor amperes (LRA) are read directly from Tables 3 and 4 for specific Motor Code and voltage. This is because the LRA is dependent only on motor size and voltage and is independent of input power (kW).

Inrush amperes (IRA) depend on LRA and the type of starter applied. The inrush can be calculated using a percentage of LRA shown in Table 5.

TABLE 3 – 60 HZ ELECTRICAL DATA

MOTOR CODE	CF	CG	CH	CJ	CK	CL	CM	CN	CP	CR	CS	CT	CU	CV	CW	CX	CY	CZ	
KW (MAX.)	125	144	161	190	214	240	257	276	302	333	368	395	435	478	514	542	578	617	
SHAFT HP	154	177	201	237	270	302	327	351	385	424	468	503	554	608	655	690	740	790	
FL EFF. – %	92	92	93	93	94	94	95	95	95	95	95	95	95	95	95	95	95.5	95.5	
FL PF	.86	.86	.86	.86	.86	.86	.86	.86	.86	.87	.87	.87	.87	.87	.87	.87	.88	.88	
VOLTS	AMPERES (MAX.)																		
200	FLA LRA	405 2598	465 3111	527 3810	618 4550	707 4900	787 5470	831 5780	921 5780	1014 7350	1085 7794	1208 —	— —	— —	— —	— —	— —	— —	
208	FLA LRA	389 2702	447 3235	507 3235	594 3962	680 4732	757 5096	799 5689	886 6011	975 6011	1043 7644	1162 8106	— —	— —	— —	— —	— —	— —	
230	FLA LRA	352 2598	404 2598	464 2865	540 3460	610 3788	685 4260	749 4755	804 5162	882 5780	944 6900	1050 7400	1130 7724	1250 —	— —	— —	— —	— —	
240	FLA LRA	337 2711	387 2711	445 3120	518 3610	585 3953	656 4445	718 4962	771 5386	845 6031	905 6031	1006 7200	1083 7722	1198 8060	— —	— —	— —	— —	
380	FLA LRA	217 1385	249 1385	285 1730	336 2153	378 2500	421 2577	453 2955	487 3254	534 3637	571 3810	636 4179	684 4480	756 4671	817 5326	879 5780	942 6782	997 5780	1065 6644
416	FLA LRA	199 1385	228 1385	260 1638	307 1967	346 2190	385 2356	412 2700	445 2976	488 3536	522 3637	581 3810	625 3810	691 4270	747 4869	810 5640	860 5780	911 5694	973 6069
440	FLA LRA	184 1177	211 1301	238 1320	281 1655	319 1865	358 2037	392 2485	397 2485	461 2976	493 2976	549 3300	591 3644	646 3644	706 4209	759 4783	813 5357	861 4783	920 5249
460	FLA LRA	176 1230	202 1360	228 1380	269 1730	305 1950	342 2130	375 2598	380 2598	441 3111	472 3111	525 3450	565 3810	618 3810	675 4400	726 5000	778 5600	824 5000	880 5488
480	FLA LRA	169 1283	194 1419	219 1440	258 1805	292 2035	328 2223	359 2711	364 2711	423 3246	452 3246	503 3600	541 3976	592 3976	647 4591	696 5217	746 5843	790 5217	843 5727
575	FLA LRA	141 909	162 909	185 1100	216 1384	250 1556	274 1700	300 1900	318 2066	353 2078	377 2413	420 2760	452 2960	500 3089	540 3550	581 4039	622 4440	659 4300	704 4200
600	FLA LRA	135 949	155 949	177 1148	207 1444	240 1624	263 1774	288 1983	305 2156	338 2168	361 2518	403 2880	433 3089	479 3223	518 3704	557 4215	596 4633	632 4484	675 4383
2300	FLA LRA	36 240	41 267	46 298	54 340	61 397	68 435	74 480	79 520	87 530	95 570	105 669	113 719	124 791	135 867	146 935	154 960	165 1008	176 1100
3300	FLA LRA	25 160	29 175	32 210	38 240	43 280	48 310	52 310	55 343	61 382	66 383	73 466	79 501	86 551	94 576	102 652	108 682	115 719	123 744
4000	FLA LRA	21 135	24 154	27 166	31 195	36 230	40 240	43 260	46 283	50 315	54 315	60 384	65 413	71 455	78 499	84 538	89 540	95 554	101 631
4160	FLA LRA	20 140	23 160	26 173	30 203	34 239	38 250	41 270	44 294	48 328	52 328	58 399	63 430	68 473	75 519	81 560	85 562	91 576	97 656

NOTE: FLA = Full Load Amps; LRA = Locked Rotor Amps

TABLE 4 – MOTOR STARTERS

TYPE STARTER	SOLID STATE STARTER	STAR DELTA		AUTO TRANSFORMER			ACROSS THE LINE	PRIMARY REACTOR		
VOLTAGE 60HZ 50 HZ	LOW 200-600 380-415	LOW 200-600 346-415	LOW 200-600 346-415	LOW 200-600 346-415	LOW 200-600 346-415	LOW/HIGH 200-4160 346-3300	LOW/HIGH 200-4160 346-3300	LOW/HIGH 200-4160 346-3300	HIGH 2300-4160 2300-3300	HIGH 2300-4160 2300-3300
TRANSITION % TAP INRUSH AS A % OF LRA	NONE — 45	CLOSED — 33	OPEN — 33	CLOSED 57.7 33	CLOSED 65 42.3	CLOSED 80 64	— — 100	CLOSED 65 65	CLOSED 80 80	

Application Data

TABLE 5 – 50 HZ ELECTRICAL DATA

MOTOR CODE	5CC	5CD	5CE	5CF	5CG	5CH	5CI	5CJ	5CK	5CL	5CM	5CN	5CO	5CP	5CQ	5CR	5CS	
KW (MAX.)	121	136	160	180	201	215	231	254	280	309	332	366	402	432	455	481	518	
SHAFT HP	148	168	198	225	252	272	292	321	353	390	419	462	507	546	575	608	658	
FL EFF. – %	91.1	92.4	92.4	93.4	93.4	94.2	94.2	94.2	94.2	94.2	94.2	94.2	94.2	94.2	94.2	94.2	94.7	
FL PF	.86	.86	.86	.86	.86	.86	.86	.86	.87	.87	.87	.87	.87	.87	.87	.87	.88	
VOLTS	AMPERES (MAX.)																	
346	FLA	224	258	302	340	380	417	437	481	528	584	630	692	578	816	860	909	982
	LRA	1385	1721	1790	2208	2467	2598	2840	3081	3350	3706	3810	4177	4830	4944	5373	5780	5780
380	FLA	204	235	275	309	346	379	398	438	481	532	572	630	690	743	783	841	895
	LRA	1385	1385	1640	1890	2144	2464	2590	2806	3050	3375	3700	3810	4400	4500	4892	5600	5491
400	FLA	194	223	261	294	329	360	378	416	457	505	543	599	656	706	744	799	850
	LRA	1458	1458	1726	1990	2257	2594	2726	2954	3211	3553	3895	4011	4632	4737	5150	5895	5780
415	FLA	187	215	252	284	317	347	364	401	441	487	526	577	632	680	717	764	819
	LRA	1283	1385	1490	1700	2031	2175	2366	2569	2794	3088	3402	3478	3810	4117	4480	5130	5108
3300	FLA	24	27	32	36	41	44	47	50	56	62	66	73	80	87	91	96	103
	LRA	159	162	209	236	241	274	294	318	317	388	423	455	499	516	572	614	644

NOTE: 1. Chiller performance for 50 Hertz applications is outside the scope of the ARI Certification Program.
 2. FLA = Full Load Amps; LRA = Locked Rotor Amps

TABLE 6 – AVAILABLE COMPRESSOR/SHELL/MOTOR COMBINATIONS (R-22 & R-134a)

COMPRESSOR CODE	COOLER SHELL	CONDENSER SHELL	MOTOR CODE		
			R-22, 60 HZ	R-134a, 60 HZ	R-22, 50 HZ
S0	BA, BB	BA, BB, CA, CB	CF, CG, CH	CF, CG, CH	5 CC, 5 CD
	CA, CB	BA, BB, CA, CB			
S1	BA, BB	BA, BB, CA, CB	CF, CG, CH, CJ, CK	CF, CG, CH, CJ, CK	5 CC, 5 CD, 5 CE, 5 CF
	CA, CB	BA, BB, CA, CB			
S2	CA, CB	CA, CB, DA, DB	CG, CH, CJ, CK, CL, CM	CF, CG, CH, CJ, CK, CL, CM	5 CD, 5 CE, 5 CF, 5 CG, 5 CH
	DA, DB, DC	CA, CB, DA, DB			
S3	DA, DB, DC	CA, CB, DA, DB	CJ, CK, CL, CM, CN, CP, CR	CG, CH, CJ, CK, CL, CM, CN, CP, CR	5 CF, 5 CG, 5 CH, 5 CI, 5 CJ, 5 CK
S4	EA, EB, EC	EA, EB, FA, FB	CK, CL, CM, CN, CP, CR, CS, CT, CU, CV	CJ, CK, CL, CM, CN, CP, CR, CS, CT, CU, CV	5 CF, 5 CG, 5 CH, 5 CI, 5 CJ, 5 CK, 5 CL, 5 CM, 5 CN, 5 CO
	FA, FB, FC	FA, FB			
S5	FA, FB, FC	FA, FB	CK, CL, CM, CN, CP, CR, CS, CT, CU, CV	CK, CL, CM, CN, CP, CR, CS, CT, CU, CV	

TABLE 7 – AVAILABLE COMPRESSOR/SHELL/MOTOR COMBINATIONS (50 HZ, R-134a ONLY)

COMPRESSOR CODE	COOLER SHELL	CONDENSER SHELL	MOTOR CODE
S0	BA, BB	BA, BB, CA, CB	5 CC, 5 CD
	CA, CB	BA, BB, CA, CB	
S1	BA, BB	BA, BB, CA, CB	5 CC, 5 CD, 5 CE, 5 CF
	CA, CB	BA, BB, CA, CB	
S2	BA, BB	BA, BB, CA, CB	5 CC, 5 CD, 5 CE, 5 CF, 5 CG, 5 CH
	CA, CB	BA, BB, CA, CB, DA, DB	
	DA, DB, DC	CA, CB, DA, DB	
S3	CA, CB	CA, CB, DA, DB	5 CC, 5 CD, 5 CE, 5 CF, 5 CG, 5 CH, 5 CI, 5 CJ, 5 CK
	DA, DB, DC	CA, CB, DA, DB	
S4	DA, DB, DC	CA, CB, DA, DB	5 CE, 5 CF, 5 CG, 5 CH, 5 CI, 5 CJ, 5 CK, 5 CL, 5 CM, 5 CN, 5 CO
	EA, EB, EC	EA, EB, FA, FB	
	FA, FB, FC	EA, EB, FA, FB	
S5	EA, EB, EC	EA, EB, FA, FB	5 CF, 5 CG, 5 CH, 5 CI, 5 CJ, 5 CK, 5 CL, 5 CM, 5 CN, 5 CO
	FA, FB, FC	EA, EB, FA, FB	

Dimensions – Std

S0 - S3 COMPRESSOR R-22 & R-134a UNITS (50 and 60 Hz)

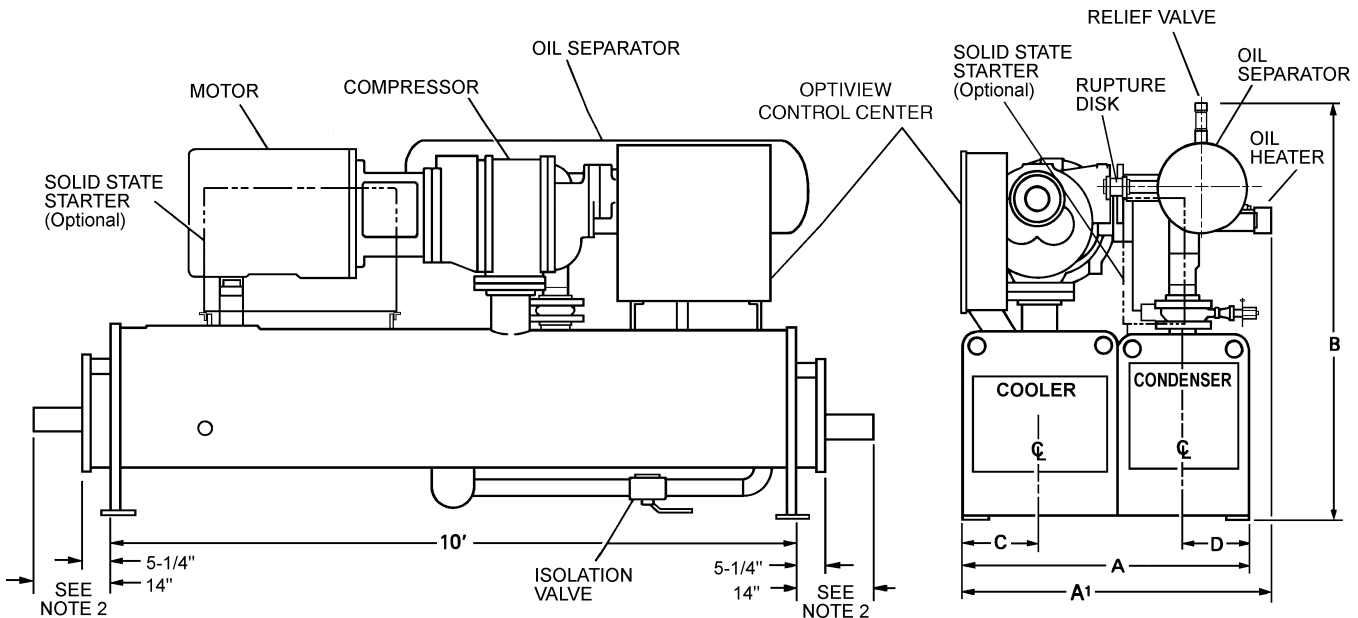

LD05888

	S0 and S1 COMPRESSOR				S2 COMPRESSOR			S2 and S3 COMPRESSOR			
	SHELL CODES (Cooler – Condenser)										
	B-B	B-C	C-B	C-C	B-B	B-C	C-B	C-C	C-D	D-C	D-D
A	4'-2-7/8"				5'-2-1/2"			5'-2-1/2"			
A'	4'-6-3/4"	4'-6-1/4"	4'-6-3/4"	4'-6-1/4"	5'-3-3/4"			5'-3-3/4"			
B – OVERALL HEIGHT³	5'-8-5/8"	5'-11-1/2"	5'-10-1/4"	5'-11-1/2"	5'-11-1/4"	6'-3-1/4"	6'-3-1/4"	6'-3-1/4"	6'-7-5/8"	6'-8-3/4"	6'-9-3/8"
C – COOLER C/L	1'-1-7/8"				1'-5"			1'-5"			
D – CONDENSER C/L	0'-11-5/8"				1'-2-1/4"			1'-2-1/4"			

Refer to Tables 6 and 7 on pages 26 & 27 for valid compressor/shell/motor combinations.

REFRIGERANT RELIEF VALVE CONNECTIONS

SHELL CODE	COOLER SIZE	CONDENSER SIZE
B, C	3/4" FPT SINGLE	3/4" FPT DUAL
D	1" FPT SINGLE	3/4" FPT DUAL

COMPRESSOR CODE	OIL SEPARATOR SIZE
S0, S1	2" RUPTURE DISK & 3/4" FPT SINGLE
S2, S3	2" RUPTURE DISK & 3/4" FPT DUAL

NOTES:

- All dimensions are approximate. Certified dimensions are available on request.
- Determine overall unit length by adding water box dimension to tube sheet length:
5-1/4" for compact return box
14" for compact water box with Victaulic water nozzles
Add 1/2" to each compact water box with optional flanged water nozzles
- Unit height includes steel mounting plates under tube sheets. To determine overall height, add 7/8" for neoprene isolators (1" for optional spring isolators).

S4 - S5 COMPRESSOR R-22 & R-134a UNITS (50 and 60 Hz)

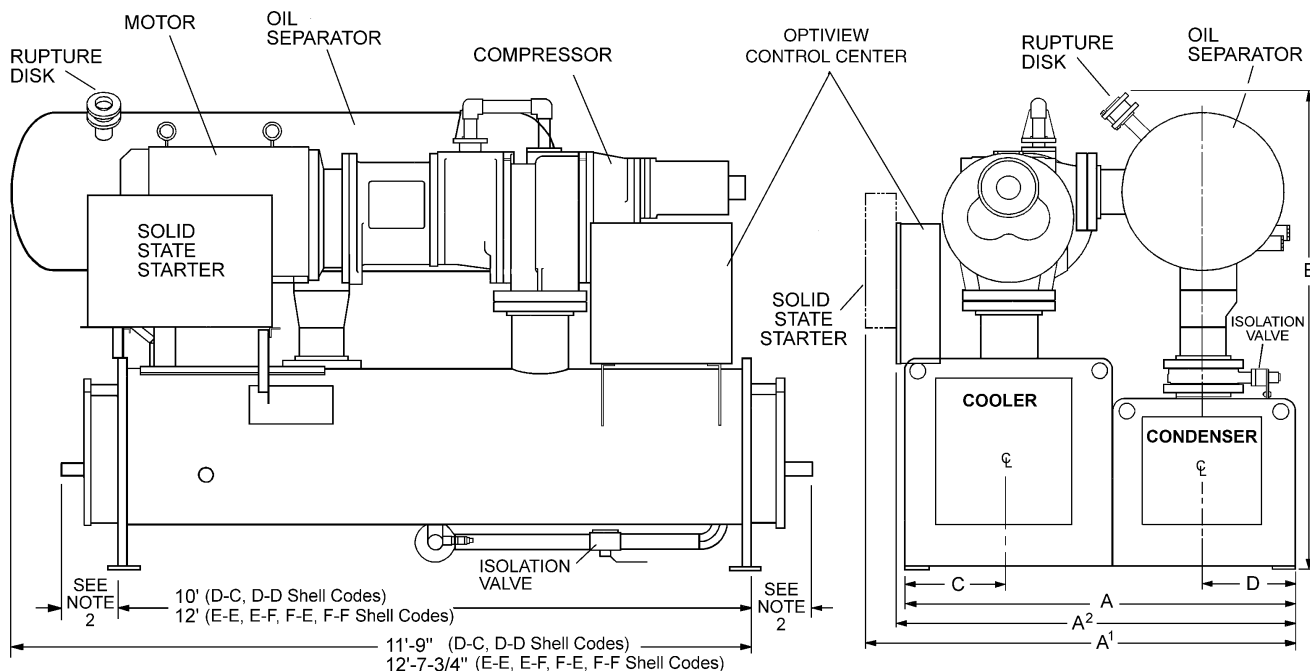

LD05889

DIMENSION	S4 COMPRESSOR		S4 and S5 COMPRESSOR			
	SHELL CODES (Cooler - Condenser)					
	D-C	D-D	E-E	E-F	F-E	F-F
A	6'-2"	6'-2"	6'-2"	6'-4-1/2"	6'-6-1/2"	6'-9"
A ¹	6'-9-7/8"	6'-9-7/8"	6'-9-7/8"	7'-0-3/8"	7'-3-5/8"	7'-2-5/8"
A ²	6'-3-3/8"	6'-3-3/8"	—	—	—	—
B - OVERALL HEIGHT ³	7'-9-1/8"	7'-9-1/8"	7'-9-1/8"	8'-2-1/4"	8'-2-1/4"	8'-2-1/4"
C - COOLER C/L	1'-7-3/4"	1'-7-3/4"	1'-7-3/4"	1'-7-3/4"	1'-10"	1'-10"
D - CONDENSER C/L	1'-5-1/4"	1'-5-1/4"	1'-5-1/4"	1'-6-1/2"	1'-5-1/4"	1'-6-1/2"

Refer to Tables 6 and 7 on pages 26 & 27 for valid compressor/shell/motor combinations.

REFRIGERANT RELIEF VALVE CONNECTIONS	
VESSEL	SIZE
COOLER	1" FPT SINGLE
CONDENSER	1" FPT DUAL
OIL SEPARATOR	1" FPT DUAL & 2" NOM RUPTURE DISK

- NOTES:** 1. All dimensions are approximate. Certified dimensions are available on request.
 2. Determine overall unit length by adding water box depth from table below to tube sheet length:

TYPE COMPACT WATER BOX	COOLER CODE			CONDENSER CODE		
	D	E	F	D	E	F
RETURN BOX	0'-5-1/2"	0'-5-1/2"	0'-7-3/4"	0'-5-1/4"	0'-5-1/4"	0'-7-5/8"
WITH VICTAULIC CONNECTION	1'-1-7/8"	1'-1-7/8"	1'-3-1/8"	1'-1-7/8"	1'-1-7/8"	1'-3-1/8"
WITH FLANGED CONNECTION	1'-2-3/8"	1'-2-3/8"	1'-3-5/8"	1'-2-3/8"	1'-2-3/8"	1'-3-5/8"

3. Unit height includes steel mounting plates under tube sheets. To determine overall installed height, add 7/8" for neoprene isolators (1" for optional spring isolators).

Dimensions – Std

COMPACT WATER BOX NOZZLE ARRANGEMENTS R-22 & R-134a UNITS

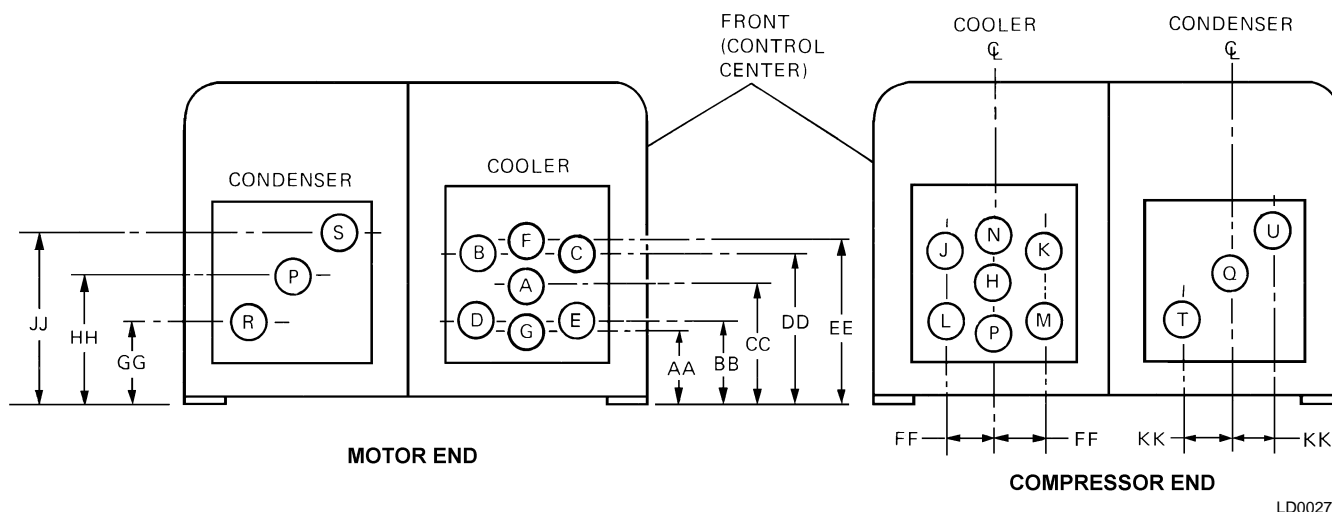

LD00274

NOZZLE ARRANGEMENTS

NO. OF PASSES	COOLER IN-OUT	COND. IN-OUT
1	A-H H-A	P-Q Q-P
2	E-B D-C M-J L-K	R-S T-U
3	P-F G-N	

COOLER NOZZLE DIMENSIONS

COOLER CODE	NOZZLE SIZE (in.)			DIMENSIONS (in.)					
	No. of Passes			AA	BB	CC	DD	EE	FF
	1	2	3						
B	8	6	4	10	11-3/4	14-3/4	17-3/4	19-1/2	5
C	10	6	6	12-3/4	13-7/8	16-3/4	19-5/8	20-3/4	5-7/8
D	12	8	6	12-7/8	15-1/4	19-1/4	23-1/4	25-7/8	6-5/8
E	12	8	6	12-7/8	15-3/8	19-3/8	23-3/8	25-7/8	7-1/2
F	14	10	8	14-5/8	17-1/2	22-1/4	27	29-7/8	9-1/4

CONDENSER NOZZLE DIMENSIONS

CONDENSER CODE	NOZZLE SIZE (in.)		DIMENSIONS (in.)			
	No. of Passes		GG	HH	JJ	KK
	1	2				
B	8	6	13	16-3/4	20-1/4	4-1/2
C	10	8	11-1/2	16-3/4	22-1/8	4-3/8
D, E	12	10	14-1/4	20	25-7/8	6
F	14	12	17	24-1/2	32	7-3/4

NOTES:

- All dimensions are approximate (shown for 150 psig DWP water side). Certified dimensions are available on request.
- Standard water nozzles are furnished as welding stub-outs with Victaulic grooves, allowing the option of welding, flanges, or use of Victaulic couplings. Factory installed, class 150 (ANSI B16.5, round slip-on, forged carbon steel with 1/16" raised face), water flanged nozzles are optional. Companion flanges, nuts, bolts and gaskets are not furnished.
- Add 7/8" to all height dimensions to obtain installed height when using neoprene mounts or 1" for optional spring vibration isolator mounts.
- One, two and three pass nozzle arrangements are available only in pairs shown and for all shell codes. Any pair of cooler nozzles may be used in combination with any pair of condenser nozzles.
- Condenser water must enter the water box through the bottom connection for proper operation of the subcooler to achieve rated performance.
- Cooler water must enter the water box through the bottom connection to achieve rated performance.
- Connected piping should allow for removal of compact water box for tube access and cleaning.

FLOOR LAYOUT – NEOPRENE ISOLATORS R-22 & R-134a UNITS

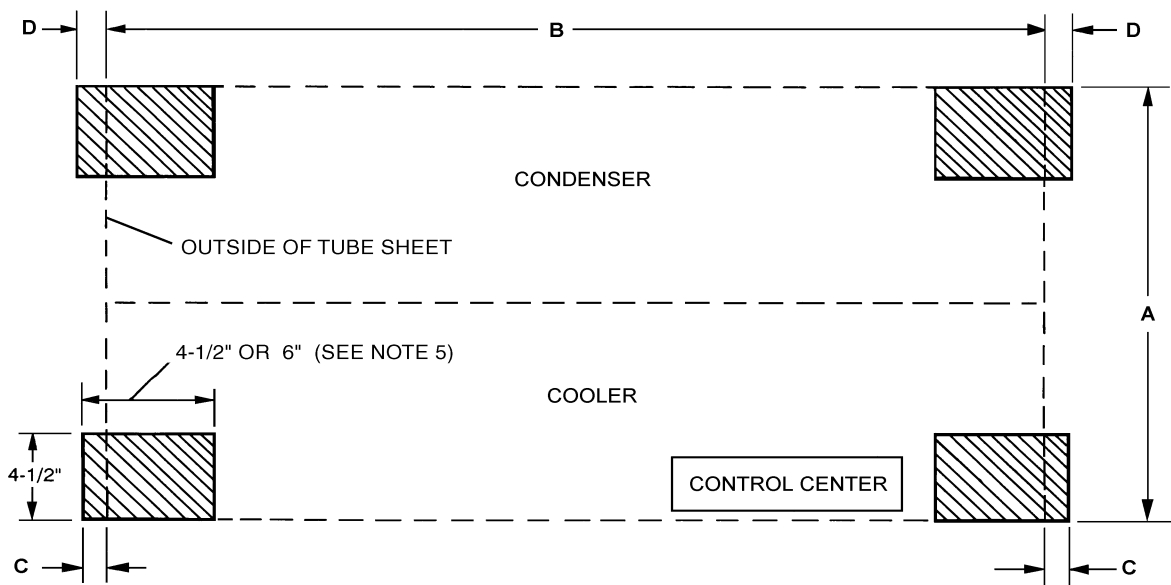

LD00271

COMPRESSOR	SHELL CODES COOLER-COND.	A TUBE SHEET WIDTH	B SHELL LENGTH (To Outside Of Tube Sheets)	C COOLER SIDE	D CONDENSER SIDE
S0, S1	B-B B-C C-B C-C	4'-2-7/8"	10'	1-7/8"	2-1/2"
S2	B-B B-C C-B	5'-2-1/2"	10'	1-7/8"	2-1/2"
S2, S3	C-C, C-D D-C, D-D	5'-2-1/2"	10'	1-7/8"	2-1/2"
S4	D-C D-D	6'-2"	10'	1-7/8"	2-1/2"
S4, S5	E-E	6'-2"	12'	1-7/8"	2-1/2"
	E-F	6'-4-1/2"			
	F-E F-F	6'-6-1/2" 6'-9"	12'	1-7/8"	2-1/2"

NOTES:

1. All dimensions are approximate. Certified dimensions are available on request.
2. Service clearance must be allowed as follows:
 - 2' at rear (condenser side) of unit and overhead.
 - 3' at front (cooler/control center side) of unit.
 - 10' (12' on S4/S5 compressor) on either end of unit for tube cleaning or replacement. A doorway or properly located opening may be used.
 - 2' on either end to allow for removal of water boxes for tube access and cleaning.
3. No special foundation required. Floor must be flat and level within 1/4", capable of carrying the operating weight of the unit.
4. Millennium unit has four steel plate foot supports located under the tube sheets at each corner of shell package. Neoprene isolator pads are field installed between foot support and floor.
5. All four neoprene isolator pads are identical. Pads are 1" thick with nominal 0.15" static deflection. Unit operating weights under 16,365 lbs. use 4-1/2" x 4-1/2" isolators; weights above 16,365 lbs use 4-1/2" x 6" isolators.
6. Loading per isolator pad equals operating weight divided by four.

Dimensions – Std

COOLER NOZZLE ARRANGEMENTS – MARINE WATER BOXES R-22 & R-134a UNITS

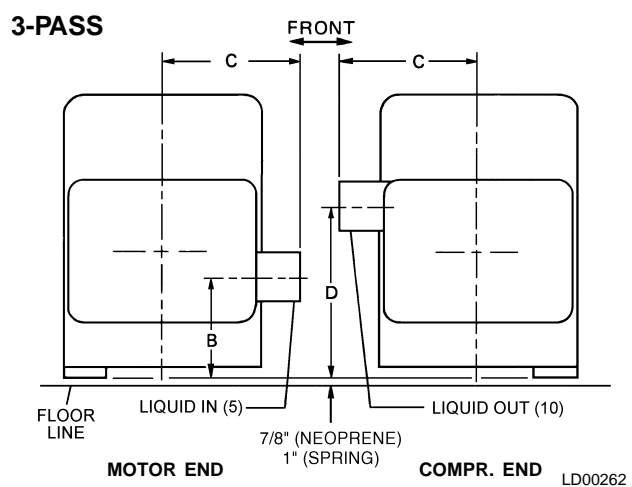
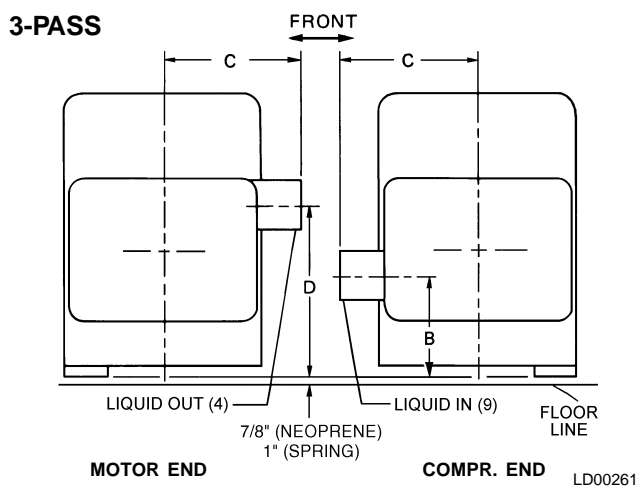
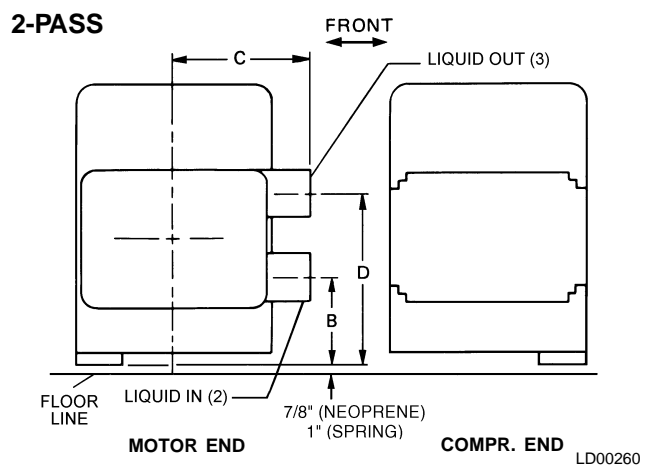
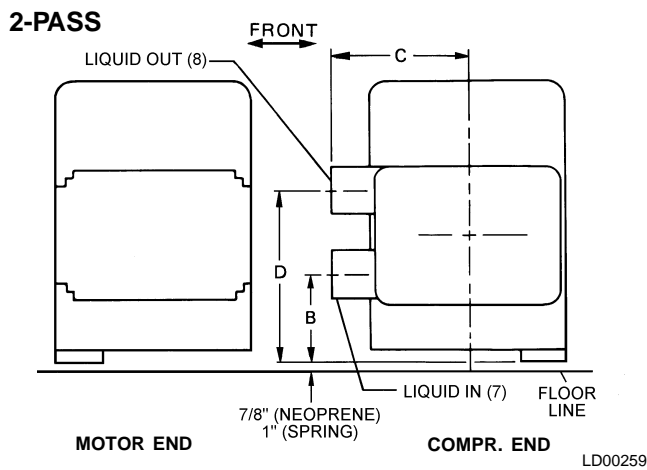
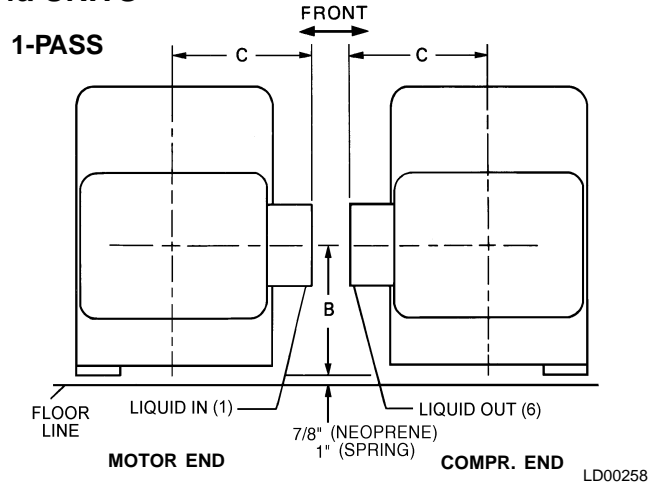
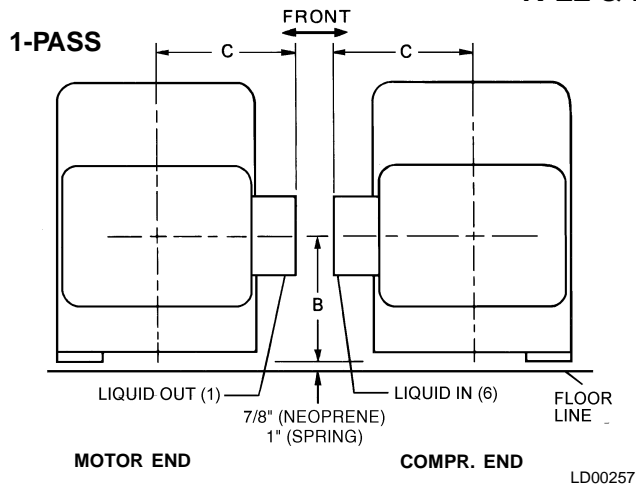

Cooler Size	DIMENSIONS (In.)														
	1-Pass					2-Pass					3-Pass				
	A	B	C	D	E	A	B	C	D	E	A	B	C	D	E
B	15-1/2	15-1/4	19	—	7-3/4	13-1/2	9-1/2	19	21	6-3/4	13-1/2	11	19	19-1/2	6-3/4
C	17-1/2	16-3/4	20-3/4	—	8-3/4	13-1/2	11-1/4	20-3/4	22-1/4	6-3/4	13-1/2	13-1/4	20-3/4	22-7/8	6-3/4
D	20	19-1/4	23-3/4	—	10	15-1/2	14-1/2	23-3/4	29-1/2	7-3/4	15-1/2	13-3/4	23-3/4	25-1/4	7-3/4
E	20	19-3/8	24-5/8	—	10	16	15-1/8	24-5/8	29-1/8	8	16	13-7/8	24-3/8	25-3/8	8
F	21	22-3/8	28-1/4	—	10-1/2	19	16-1/4	28-1/4	33	9-1/2	17	15-1/4	28-1/4	29-1/4	8-1/2

COOLER NOZZLE ARRANGEMENTS – MARINE WATER BOXES R-22 & R-134a UNITS

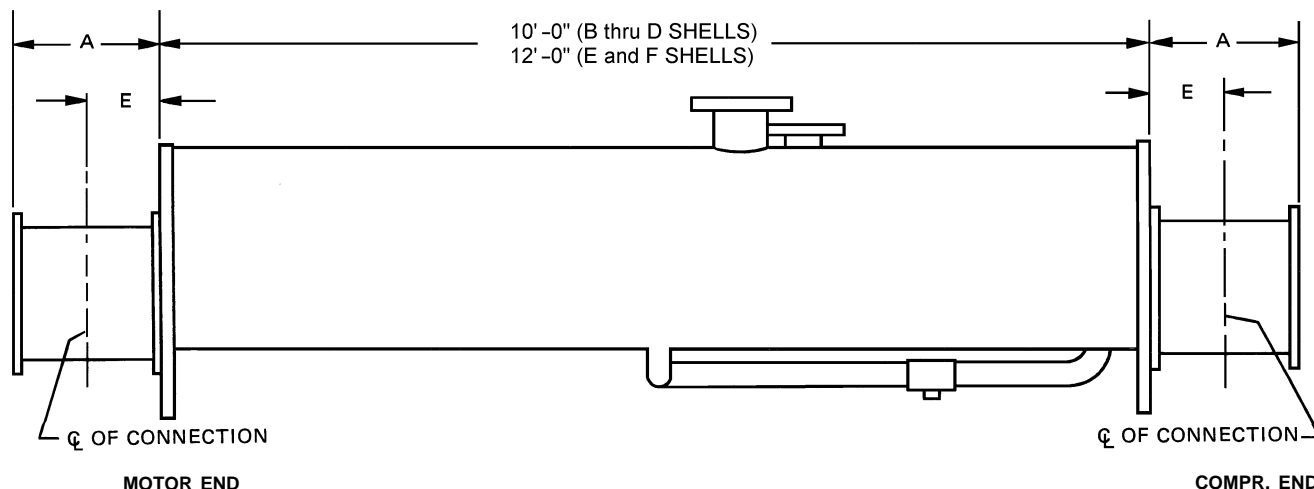

LD00263

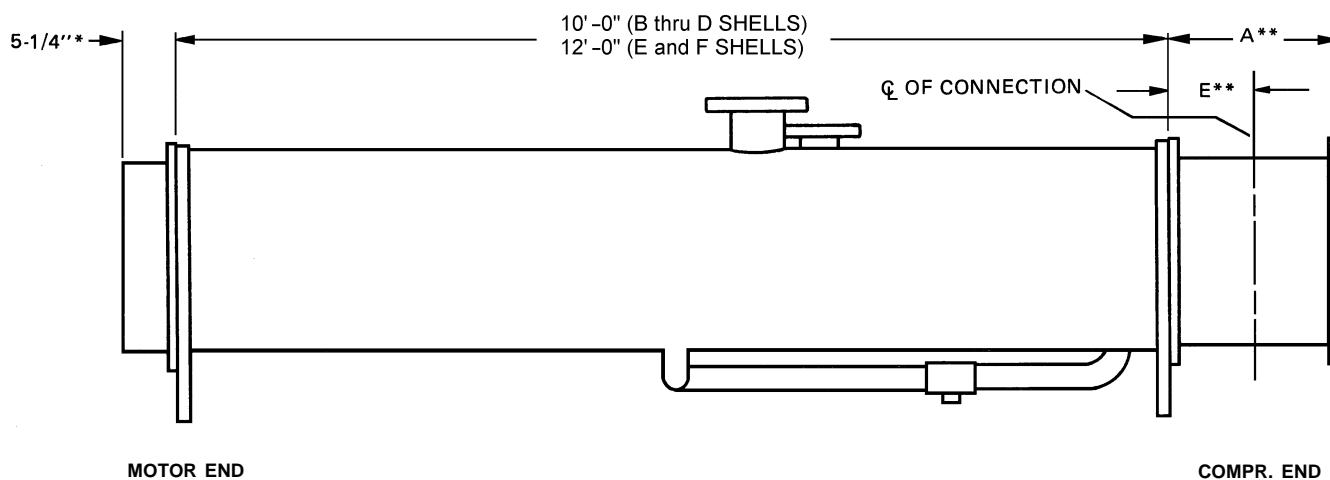

LD00264

* Applies to compressor end if connections are on motor end.
 ** Applies to motor end if connections are on motor end.

COOLER NOZZLE SIZES

Cooler Code	Nozzle Size (In.) No. of Passes		
	1	2	3
B	8	6	4
C	10	6	6
D	12	8	6
E	12	8	6
F	12	10	8

WEIGHTS

(To be added to Standard Unit Weights on pages 36-37)

Cooler Code	Shipping Weight Increase – Lbs			Operating Weight Increase – Lbs		
	1-Pass	2-Pass	3-Pass	1-Pass	2-Pass	3-Pass
B	554	295	562	788	391	755
C	810	417	668	1207	592	955
D	872	439	768	1316	600	1090
E	1040	607	996	1674	924	1535
F	1280	875	1130	1900	1025	1685

Dimensions – Std

CONDENSER NOZZLE ARRANGEMENTS – MARINE WATER BOXES R-22 & R-134a UNITS

1-PASS

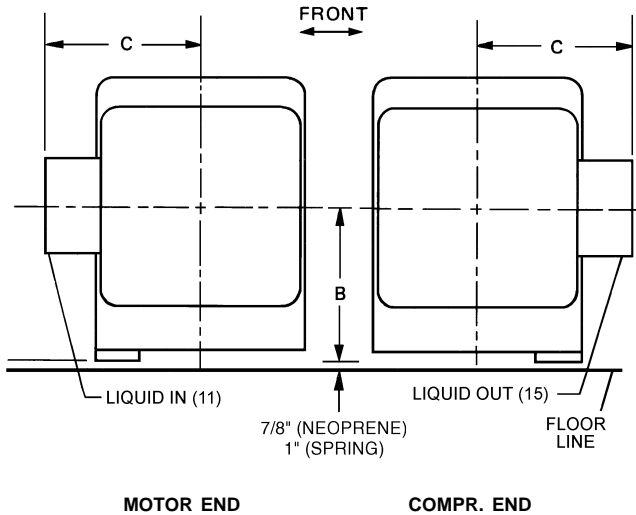

LD00265

1-PASS

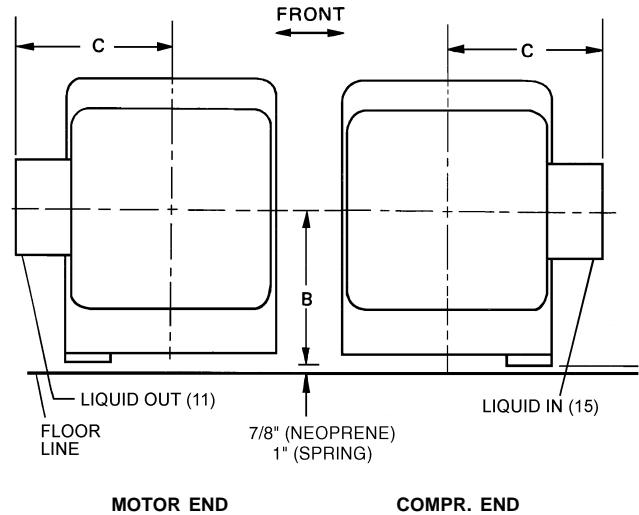

LD00266

2-PASS

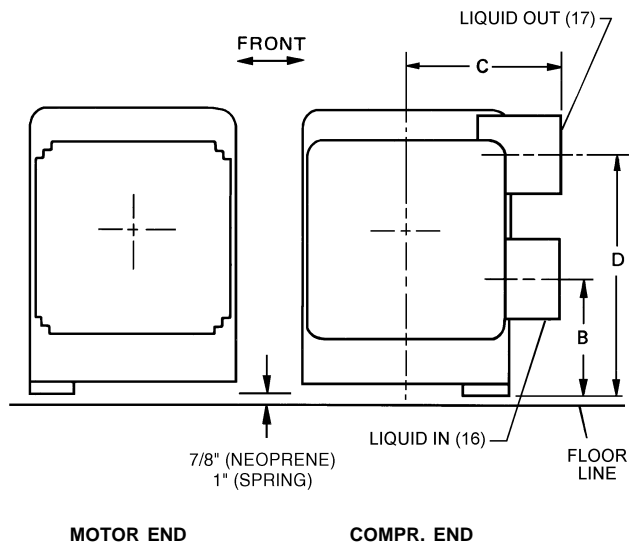

LD00267

2-PASS

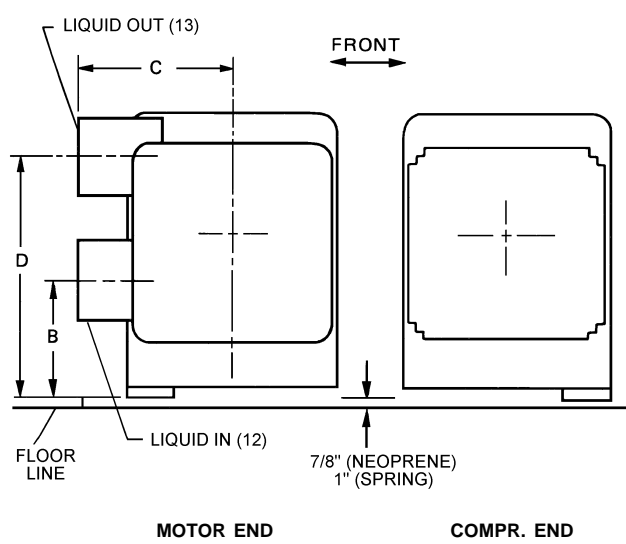

LD00268

Condenser Size	DIMENSIONS (In.)									
	1-Pass					2-Pass				
	A	B	C	D	E	A	B	C	D	E
B	15-1/2	16-7/8	17-5/8	—	7-3/4	13-1/2	11-1/8	17-5/8	22-5/8	6-3/4
C	17-1/2	16-3/4	18-1/2	—	8-3/4	15-1/2	12	18-1/2	26	7-3/4
D	20	20	21-1/8	—	10	17-1/2	15	21-1/8	31-3/4	8-3/4
E	20	20	21-1/8	—	10	17-1/2	15	21-1/8	31-3/4	8-3/4
F	21	24-1/2	25-1/8	—	10-1/2	21	18-1/2	25-1/8	38-1/4	10-1/2

CONDENSER NOZZLE ARRANGEMENTS – MARINE WATER BOXES R-22 & R-134a UNITS

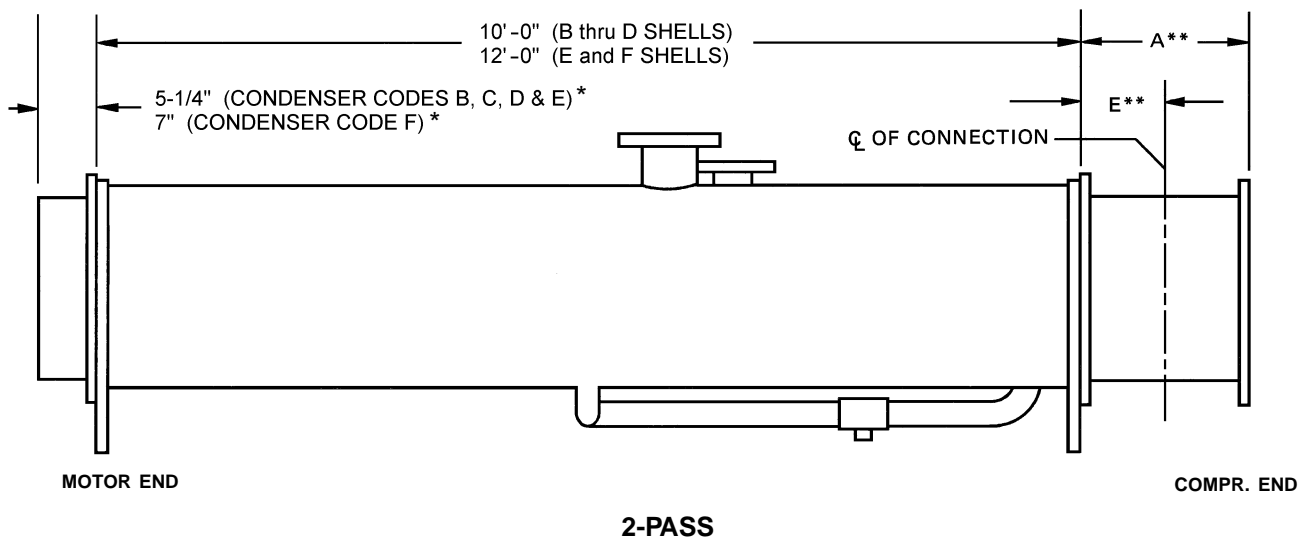
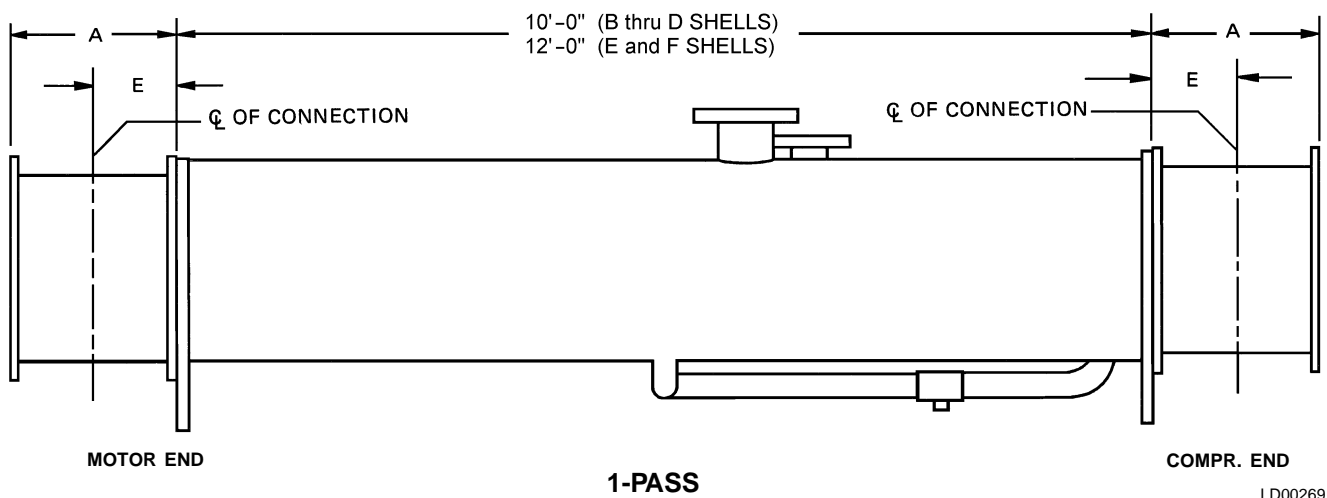

* Applies to compressor end if connections are on motor end.

** Applies to motor end if connections are on motor end.

CONDENSER NOZZLE SIZES

Condenser Code	Nozzle Size (In.) No. of Passes	
	1	2
B	8	6
C	10	8
D	12	10
E	12	10
F	14	12

WEIGHTS

(To be added to Standard Unit Weights on pages 36-37)

Condenser Code	Shipping Weight Increase – Lbs		Operating Weight Increase – Lbs	
	1-Pass	2-Pass	1-Pass	2-Pass
B	542	241	744	327
C	686	328	1018	475
D	818	317	1235	466
E	818	317	1235	466
F	1004	459	1586	704

Weights – Std

R-22 & R-134a UNITS 50 AND 60 HZ

SHELL CODE COOLER – COND.	COM-PRES-SOR	SHIP-PING WT. (Lbs.)	OPER-ATING WT. (Lbs.)	REFRIG-ERANT CHARGE (Lbs. R-22)	REFRIG-ERANT CHARGE (Lbs. R-134a)	SHELL CODE COOLER – COND.	COM-PRES-SOR	SHIP-PING WT. (Lbs.)	OPER-ATING WT. (Lbs.)	REFRIG-ERANT CHARGE (Lbs. R-22)	REFRIG-ERANT CHARGE (Lbs. R-134a)
BA-BA	S0	8,388	9,019	490	441	CA-DA	S2	13,357	14,765	750	675
BA-BB	S0	8,538	9,235	490	441	CA-DB	S2	13,874	15,506	750	675
BB-BA	S0	8,494	9,187	460	414	CB-DA	S2	13,588	15,093	750	675
BB-BB	S0	8,644	9,403	460	414	CB-DB	S2	14,105	15,833	750	675
BA-CA	S0	9,142	9,996	520	468	DA-CA	S2	13,293	14,480	840	756
BA-CB	S0	9,416	10,388	520	468	DA-CB	S2	13,577	14,872	840	756
BB-CA	S0	9,271	10,186	480	432	DB-CA	S2	13,668	15,008	840	756
BB-CB	S0	9,545	10,579	480	432	DB-CB	S2	13,941	15,400	840	756
CA-BA	S0	9,297	10,084	620	558	DC-CA	S2	14,026	15,552	840	756
CA-BB	S0	9,448	10,299	620	558	DC-CB	S2	14,299	15,943	840	756
CB-BA	S0	9,528	10,412	620	558	DA-DA	S2	14,549	16,124	950	855
CB-BB	S0	9,679	10,627	620	558	DA-DB	S2	15,066	16,864	950	855
CA-CA	S0	10,011	11,020	650	585	DB-DA	S2	14,869	16,608	910	819
CA-CB	S0	10,285	11,413	650	585	DB-DB	S2	15,386	17,348	910	819
CB-CA	S0	10,242	11,348	650	585	DC-DA	S2	15,215	17,437	840	756
CB-CB	S0	10,516	11,740	650	585	DC-DB	S2	15,732	16,781	840	756
BA-BA	S1	8,454	9,085	490	441	CA-CA	S3	12,360	13,372	—	612
BA-BB	S1	8,608	9,301	490	441	CA-CB	S3	12,633	13,764	—	612
BB-BA	S1	8,560	9,253	460	414	CB-CA	S3	12,591	13,698	—	612
BB-BB	S1	8,711	9,469	460	414	CB-CB	S3	12,865	14,090	—	612
BA-CA	S1	9,208	9,974	520	468	CA-DA	S3	13,574	14,983	—	675
BA-CB	S1	9,482	10,454	520	468	CA-DB	S3	14,090	15,726	—	675
BB-CA	S1	9,337	10,252	480	432	CB-DA	S3	13,804	15,313	—	675
BB-CB	S1	9,611	10,645	480	432	CB-DB	S3	14,324	16,054	—	675
CA-BA	S1	9,363	10,150	620	558	DA-CA	S3	13,497	14,673	840	756
CA-BB	S1	9,513	10,365	620	558	DA-CB	S3	13,770	15,065	840	756
CB-BA	S1	9,594	10,478	620	558	DB-CA	S3	13,861	15,201	840	756
CB-BB	S1	9,745	10,693	620	558	DB-CB	S3	14,134	15,593	840	756
CA-CA	S1	10,077	11,086	650	585	DC-CA	S3	14,219	15,744	840	756
CA-CB	S1	10,351	11,479	650	585	DC-CB	S3	14,491	16,135	840	756
CB-CA	S1	10,308	11,414	650	585	DA-DA	S3	14,741	16,316	950	855
CB-CB	S1	10,582	11,806	650	585	DA-DB	S3	15,258	17,057	950	855
BA-BA	S2	10,542	11,174	—	441	DB-DA	S3	15,061	16,800	910	819
BA-BB	S2	10,693	11,390	—	441	DB-DB	S3	15,578	17,541	910	819
BB-BA	S2	10,648	11,342	—	414	DC-DA	S3	15,408	17,333	840	756
BB-BB	S2	10,797	11,558	—	414	DC-DB	S3	15,925	18,073	840	756
BA-CA	S2	11,298	12,065	—	468	DA-CA	S4	17,068	18,247	—	740
BA-CB	S2	11,571	12,547	—	468	DA-CB	S4	17,341	18,639	—	740
BB-CA	S2	11,426	12,342	—	432	DB-CA	S4	17,431	18,776	—	740
BB-CB	S2	11,701	12,735	—	432	DB-CB	S4	17,705	19,168	—	740
CA-BA	S2	11,452	12,241	—	558	DC-CA	S4	17,791	19,320	—	740
CA-BB	S2	11,604	12,457	—	558	DC-CB	S4	18,064	19,710	—	740
CB-BA	S2	11,683	12,567	—	558	DA-DA	S4	18,313	19,893	—	830
CB-BB	S2	11,833	12,783	—	558	DA-DB	S4	18,833	20,634	—	830
CA-CA	S2	12,146	13,155	680	612	DB-DA	S4	18,635	20,378	—	800
CA-CB	S2	12,419	13,547	680	612	DB-DB	S4	19,153	21,119	—	800
CB-CA	S2	12,377	13,483	680	612	DC-DA	S4	18,983	20,912	—	740
CB-CB	S2	12,650	13,874	680	612	DC-DB	S4	19,426	21,652	—	740

R-22 & R-134a UNITS 50 AND 60 HZ

SHELL CODE COOLER - COND.	COMPRESSOR	SHIPPING WT. (Lbs.)	OPERATING WT. (Lbs.)	REFRIGERANT CHARGE (Lbs. R-22)	REFRIGERANT CHARGE (Lbs. R-134a)	SHELL CODE COOLER - COND.	COMPRESSOR	SHIPPING WT. (Lbs.)	OPERATING WT. (Lbs.)	REFRIGERANT CHARGE (Lbs. R-22)	REFRIGERANT CHARGE (Lbs. R-134a)
EA-EA	S4	20,460	21,890	1,400	1,260	EA-EA	S5	20,777	22,210	—	1,260
EA-EB	S4	21,104	22,743	1,400	1,260	EA-EB	S5	21,423	23,065	—	1,260
EB-EA	S4	20,955	22,484	1,350	1,215	EB-EA	S5	21,275	22,807	—	1,215
EB-EB	S4	21,533	23,337	1,350	1,215	EB-EB	S5	21,853	23,682	—	1,215
EC-EA	S4	21,362	23,139	1,300	1,170	EC-EA	S5	21,681	23,462	—	1,170
EC-EB	S4	22,000	23,991	1,300	1,170	EC-EB	S5	22,322	24,317	—	1,170
EA-FA	S4	23,485	25,592	1,520	1,368	EA-FA	S5	23,808	25,919	—	1,368
EA-FB	S4	24,695	27,192	1,520	1,368	EA-FB	S5	25,020	27,521	—	1,368
EB-FA	S4	23,914	26,180	1,520	1,368	EB-FA	S5	24,240	26,508	—	1,368
EB-FB	S4	25,119	27,781	1,450	1,305	EB-FB	S5	25,445	28,112	—	1,305
EC-FA	S4	24,382	26,840	1,450	1,305	EC-FA	S5	24,707	27,171	—	1,305
EC-FB	S4	25,592	28,435	1,450	1,305	EC-FB	S5	25,919	28,769	—	1,305
FA-EA	S4	22,922	24,998	—	1,690	FA-EA	S5	23,274	25,280	—	1,690
FA-EB	S4	23,638	25,853	—	1,690	FA-EB	S5	23,920	26,135	—	1,690
FB-EA	S4	23,711	25,902	—	1,690	FB-EA	S5	23,991	26,184	—	1,690
FB-EB	S4	24,288	26,757	—	1,690	FB-EB	S5	24,568	27,036	—	1,620
FC-EA	S4	24,171	27,076	—	1,620	FC-EA	S5	24,453	27,356	—	1,620
FC-EB	S4	25,141	27,929	—	1,620	FC-EB	S5	25,423	28,211	—	1,620
FA-FA	S4	25,977	28,655	2,000	1,800	FA-FA	S5	26,257	28,936	2,000	1,800
FA-FB	S4	27,187	30,256	2,000	1,800	FA-FB	S5	27,467	30,536	2,000	1,800
FB-FA	S4	26,626	29,552	2,000	1,800	FB-FA	S5	26,906	29,832	2,000	1,800
FB-FB	S4	27,830	31,152	1,900	1,710	FB-FB	S5	28,111	31,433	1,900	1,710
FC-FA	S4	27,148	30,729	1,900	1,710	FC-FA	S5	27,759	31,009	1,900	1,710
FC-FB	S4	28,688	32,324	1,900	1,710	FC-FB	S5	28,969	32,604	1,900	1,710

- NOTE:**
1. Calculate total chiller weight by adding motor weight, solid state starter weight, and marine water box weights, if applicable.
 2. Shipping weight includes refrigerant and oil charge. Operating weight includes water in tubes and water boxes.
 3. Weights based on standard tubes in coolers and condensers.
 4. Operating weight based on R-22. Subtract difference in refrigerant charge if using R-134a.

MOTOR WEIGHTS

MOTOR CODE		WEIGHT (Lbs)
60 Hz	50 Hz	
CF	5 CC	1,080
CG	5 CC	1,080
CH	5 CD	1,120
CJ	5 CE	1,120
CK	5 CF	1,460
CL	5 CG	1,520
CM	5 CH	1,930
CN	5 CI	1,930
CP	5 CJ	1,980
CR	5 CK	1,980
CS	5 CL	2,370
CT	5 CM	2,480
CU	5 CN	2,480
CV	5 CO	2,635

SOLID STATE STARTER WEIGHT

SIZE	LBS
7L, 14L	200
26L, 33L	300

Dimensions – Metric

S0 - S3 COMPRESSOR R-22 & R-134a UNITS (50 and 60 Hz)

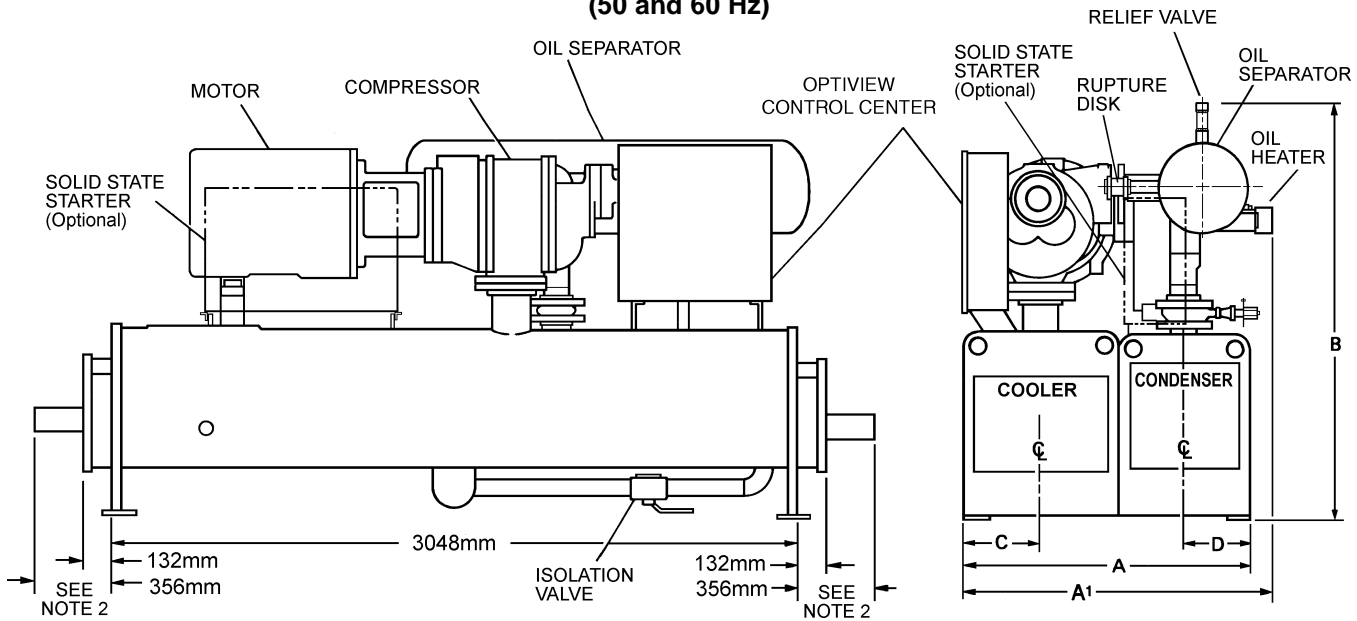

LD05890

DIMENSIONS (mm)

	S0 and S1 COMPRESSOR				S2 COMPRESSOR				S2 and S3 COMPRESSOR			
	SHELL CODES (Cooler – Condenser)											
	B-B	B-C	C-B	C-C	B-B	B-C	C-B	C-C	C-D	D-C	D-D	
A – TUBE SHEET WIDTH	1,292	1,292	1,292	1,292	1,588	1,588	1,588	1,588	1,588	1,588	1,588	
A' – OVERALL WIDTH	1,349	1,349	1,349	1,349	1,591	1,591	1,591	1,591	1,591	1,591	1,591	
B – OVERALL HEIGHT ³	1,816	1,895	1,857	1,899	1,848	1,946	1,946	1,946	2,054	2,102	2,102	
C – COOLER C/L	351	351	351	351	432	432	432	432	432	432	432	
D – CONDENSER C/L	295	295	295	295	362	362	362	362	362	362	362	

Refer to Tables 6 and 7 on pages 26 & 27 for valid compressor/shell/motor combinations.

REFRIGERANT RELIEF VALVE CONNECTIONS

SHELL CODE	COOLER SIZE	CONDENSER SIZE
B, C	3/4" FPT SINGLE	3/4" FPT DUAL
D	1" FPT SINGLE	3/4" FPT DUAL

COMPRESSOR CODE	OIL SEPARATOR SIZE
S0, S1	2" RUPTURE DISK & 3/4" FPT SINGLE
S2, S3	2" RUPTURE DISK & 3/4" FPT DUAL

NOTES:

- All dimensions are approximate. Certified dimensions are available on request.
- Determine overall unit length by adding water box dimension to tube sheet length:
132mm for compact return box
356mm for compact water box with Victaulic water nozzles
Add 12.6mm to each compact water box with optional flanged water nozzles
- Unit height includes steel mounting plates under tube sheets. To determine overall installed height, add 22mm for neoprene isolators (25 mm for optional spring isolators).

S4 - S5 COMPRESSOR R-22 & R-134a UNITS (50 and 60 Hz)

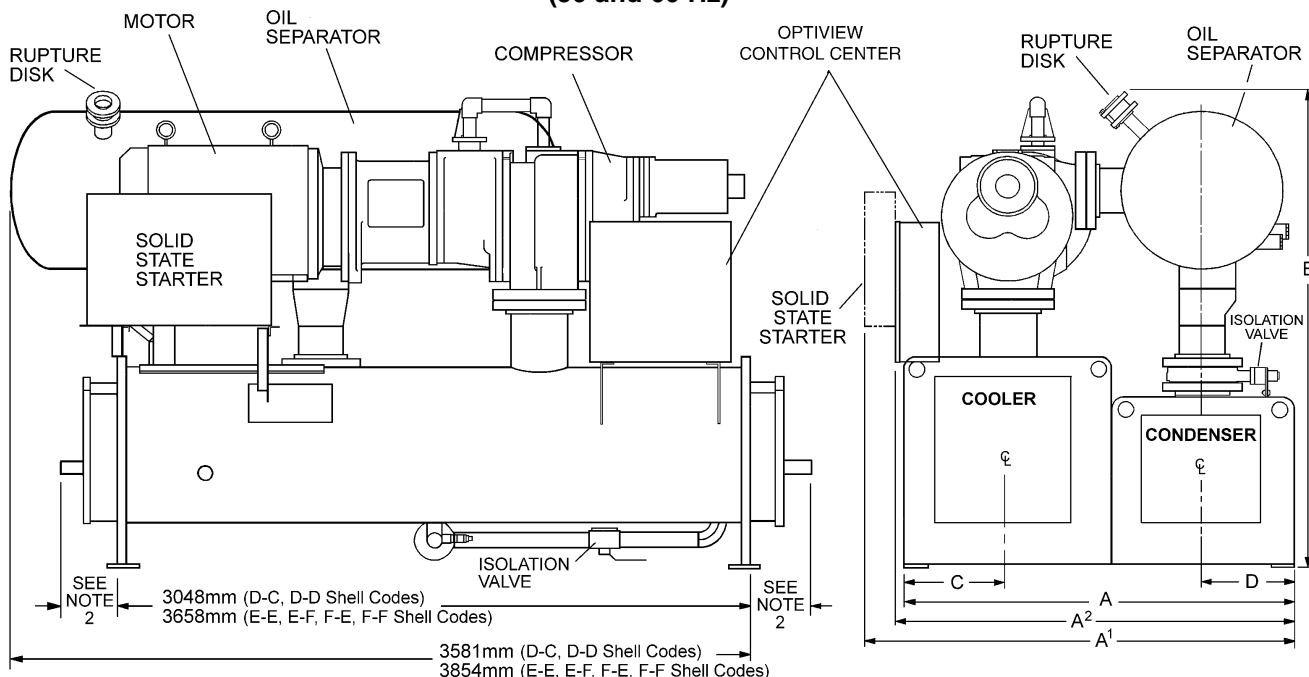

LD05891

DIMENSIONS (mm)

	S4 COMPRESSOR		S4 and S5 COMPRESSOR			
	SHELL CODES (Cooler – Condenser)					
	D-C	D-D	E-E	E-F	F-E	F-F
A – TUBE SHEET WIDTH	1,880	1,880	1,880	1,943	1,994	2,057
A¹ – WITH SOLID STATE STARTER	2,080	2,080	2,080	2,143	2,226	2,200
A² – OVERALL WIDTH (Less S.S.S)	1,915	1,915	—	—	—	—
B – OVERALL HEIGHT ³	2,365	2,365	2,365	2,496	2,496	2,496
C – COOLER C/L	502	502	502	502	559	559
D – CONDENSER C/L	438	438	438	470	438	470

Refer to Tables 6 and 7 on pages 26 & 27 for valid compressor/shell/motor combinations.

REFRIGERANT RELIEF VALVE CONNECTIONS

VESSEL	SIZE
COOLER	1" FPT SINGLE
CONDENSER	1" FPT DUAL
OIL SEPARATOR	1" FPT DUAL & 2" NOM RUPTURE DISK

- NOTES:** 1. All dimensions are approximate. Certified dimensions are available on request.
 2. Determine overall unit length by adding water box depth from table below to tube sheet length:

TYPE COMPACT WATER BOX	COOLER CODE			CONDENSER CODE		
	D	E	F	D	E	F
RETURN BOX	140	140	197	133	133	194
WITH VICTAULIC CONNECTION	352	352	384	352	352	384
WITH FLANGED CONNECTION	365	365	397	365	365	397

3. Unit height includes steel mounting plates under tube sheets. To determine overall installed height, add 22mm for neoprene isolators (25.4 for optional spring isolators).

Dimensions – Metric

COMPACT WATER BOX NOZZLE ARRANGEMENTS R-22 and R-134a UNITS

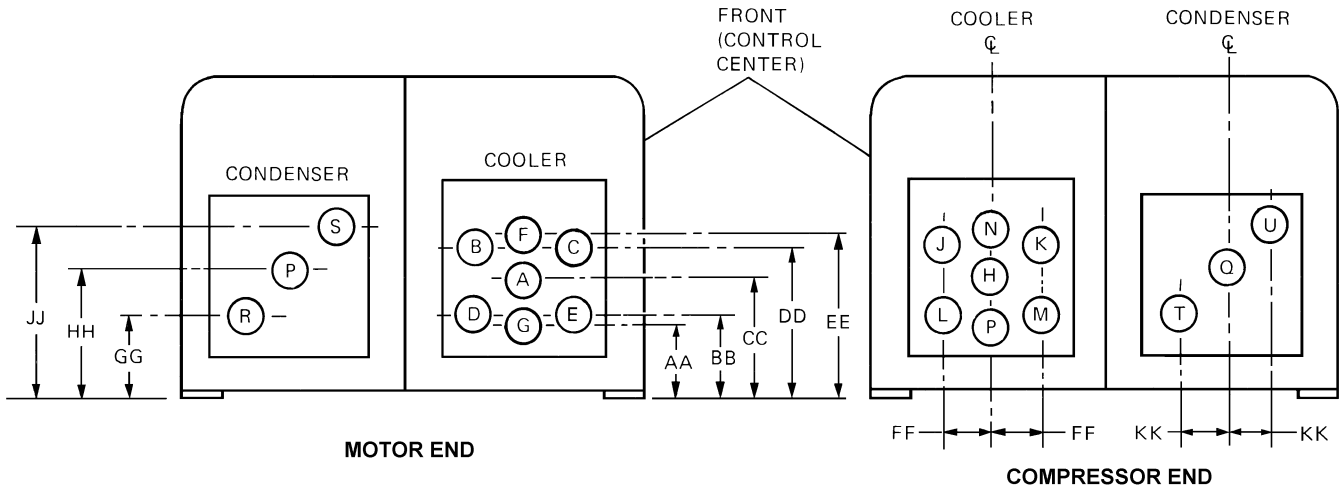

LD00274

NOZZLE ARRANGEMENTS

NO. OF PASSES	COOLER IN-OUT	COND. IN-OUT
1	A - H	P - Q
	H - A	Q - P
2	E - B	R - S
	D - C	T - U
	M - J	
	L - K	
3	P - F	
	G - N	

COOLER NOZZLE DIMENSIONS

COOLER CODE	NOZZLE SIZE (in.)			DIMENSIONS (mm)					
	No. of Passes			AA	BB	CC	DD	EE	FF
	1	2	3						
B	8	6	4	254	298	375	451	495	127
C	10	6	6	324	352	425	498	527	149
D	12	8	6	327	387	489	591	657	168
E	12	8	6	327	391	492	594	657	191
F	14	10	8	371	445	565	686	759	235

CONDENSER NOZZLE DIMENSIONS

COOLER CODE	NOZZLE SIZE (in.)		DIMENSIONS (mm)			
	No. of Passes		GG	HH	JJ	KK
	1	2				
B	8	6	330	425	514	114
C	10	8	292	425	562	111
D	12	10	368	514	660	152
E	12	10	375	521	667	152
F	14	12	432	622	813	197

NOTES:

- All dimensions are approximate (shown for 1031 KPa DWP water side). Certified dimensions are available on request.
- Standard water nozzles are furnished as welding stub-outs with Victaulic grooves, allowing the option of welding, flanges, or use of Victaulic couplings. Factory installed, class 150 (ANSI B16.5, round slip-on, forged carbon steel with 1/16" raised face), water flanged nozzles are optional. Companion flanges, nuts, bolts and gaskets are not furnished.
- Add 22mm to all height dimensions to obtain installed height when using neoprene mounts or 25mm for optional spring vibration isolator mounts.
- One, two and three-pass nozzle arrangements are available only in pairs shown and for all shell codes. Any pair of cooler nozzles may be used in combination with any pair of condenser nozzles.
- Condenser water must enter the water box through the bottom connection for proper operation of the subcooler to achieve rated performance.
- Cooler water must enter the water box through the bottom connection to achieve rated performance.
- Connected piping should allow for removal of compact water box for tube access and cleaning.

FLOOR LAYOUT – NEOPRENE ISOLATORS

R-22 & R-134a UNITS

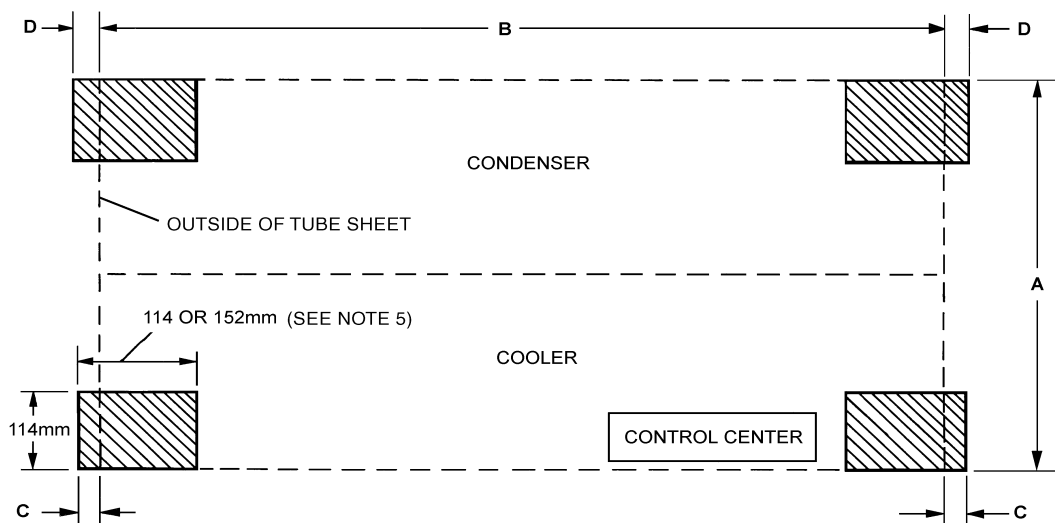

LD00289

COMPRESSOR	SHELL CODES COOLER - COND.	A TUBE SHEET WIDTH	B SHELL LENGTH (To Outside Of Tube Sheets)	C COOLER SIDE	D CONDENSER SIDE
S0, S1	B-B B-C C-B C-C	1292mm	3048mm	48mm	64mm
S2	B-B B-C C-B	1588mm	3048mm	48mm	64mm
S2, S3	C-C C-D	1588mm	3048mm	48mm	64mm
	D-C D-D	1588mm	3048mm	48mm	64mm
S4	D-C D-D	1880mm	3048mm	48mm	64mm
S4, S5	E-E E-F	1880mm 1943mm	3658mm	48mm	64mm
	F-E F-F	1994mm 2057mm	3658mm	48mm	64mm

NOTES:

- All dimensions are approximate. Certified dimensions are available on request.
- Service clearance must be allowed as follows:
 - 610mm at rear (condenser side) of unit and overhead.
 - 915mm at front (cooler/control center side) of unit.
 - 3050mm (3660mm on S4/S5 compressor) on either end of unit for tube cleaning or replacement. A doorway or properly located opening may be used.
 - 610mm on either end to allow for removal of water boxes for tube access and cleaning.
- No special foundation required. Floor must be flat and level within 6mm, capable of carrying the operating weight of the unit.
- Unit has four steel plate foot supports located under the tube sheets at each corner of shell package. Neoprene isolator pads are field installed between foot support and floor.
- All four neoprene isolator pads are identical. Pads are 25mm thick. Unit operating weights under 7423 kg. use 114mm x 114mm isolators; weights above 7423 kg. use 114mm x 152mm isolators.
- Loading per isolator pad equals operating weight divided by four.

Dimensions – Metric

COOLER NOZZLE ARRANGEMENTS – MARINE WATER BOXES

R-22 and R-134a UNITS

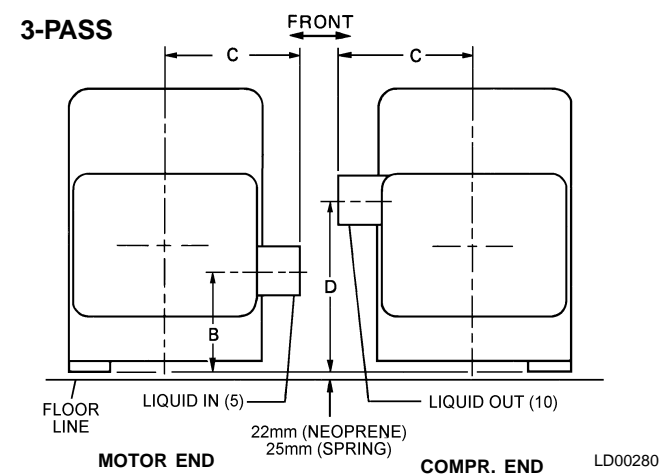
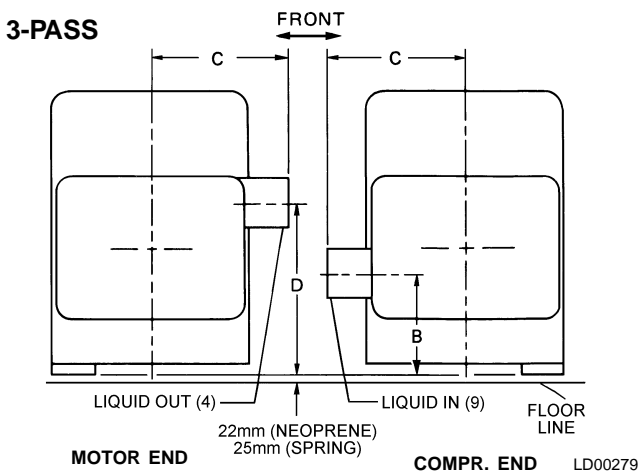
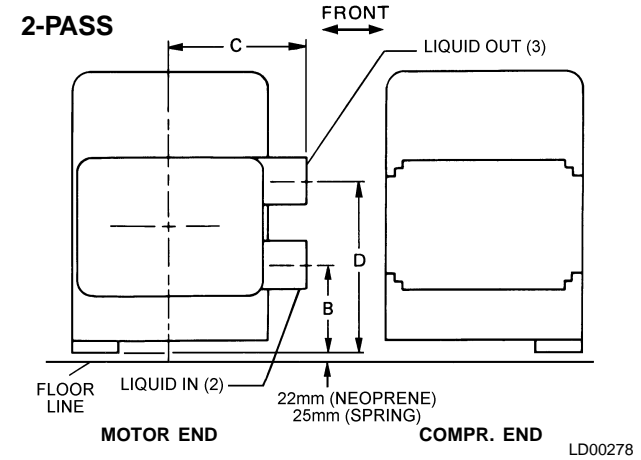
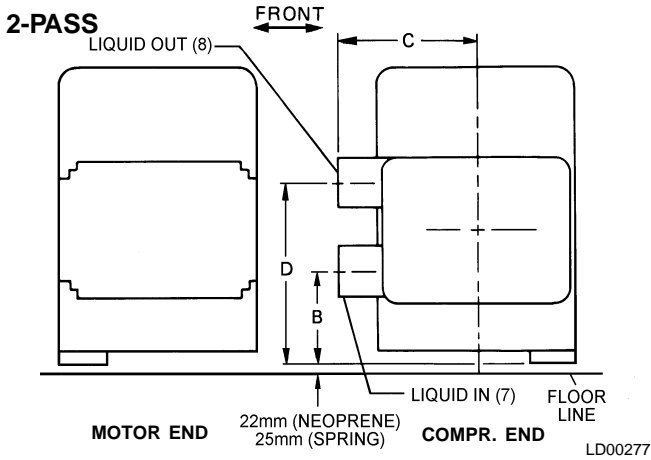
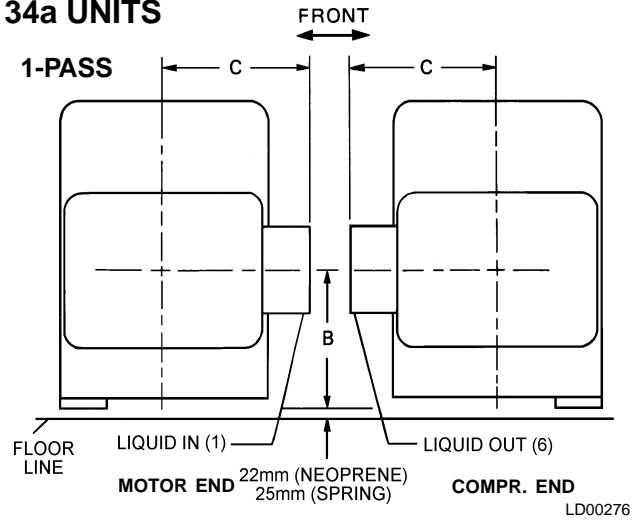
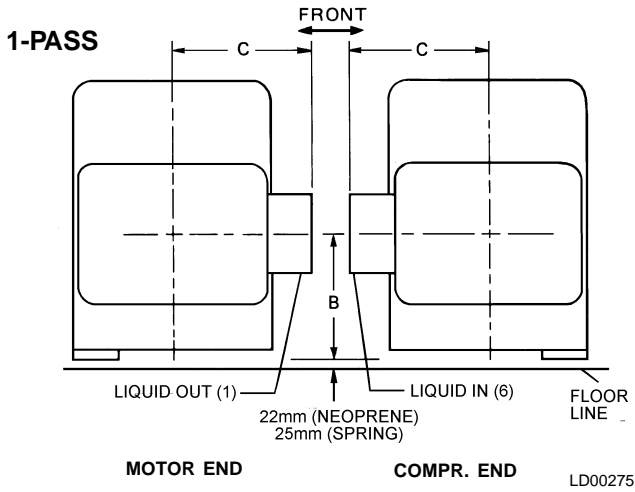

Cooler Size	DIMENSIONS (mm)														
	1-Pass					2-Pass					3-Pass				
	A	B	C	D	E	A	B	C	D	E	A	B	C	D	E
B	394	387	483	—	197	343	241	483	533	171	343	279	483	495	171
C	445	425	527	—	222	343	286	527	565	171	343	337	527	581	171
D	508	489	603	—	254	394	368	603	749	197	394	349	603	641	197
E	508	492	625	—	254	406	384	625	740	203	406	352	619	644	203
F	533	568	719	—	266	483	413	718	838	241	432	387	718	743	216

COOLER NOZZLE ARRANGEMENTS – MARINE WATER BOXES

R-22 & R-134a UNITS

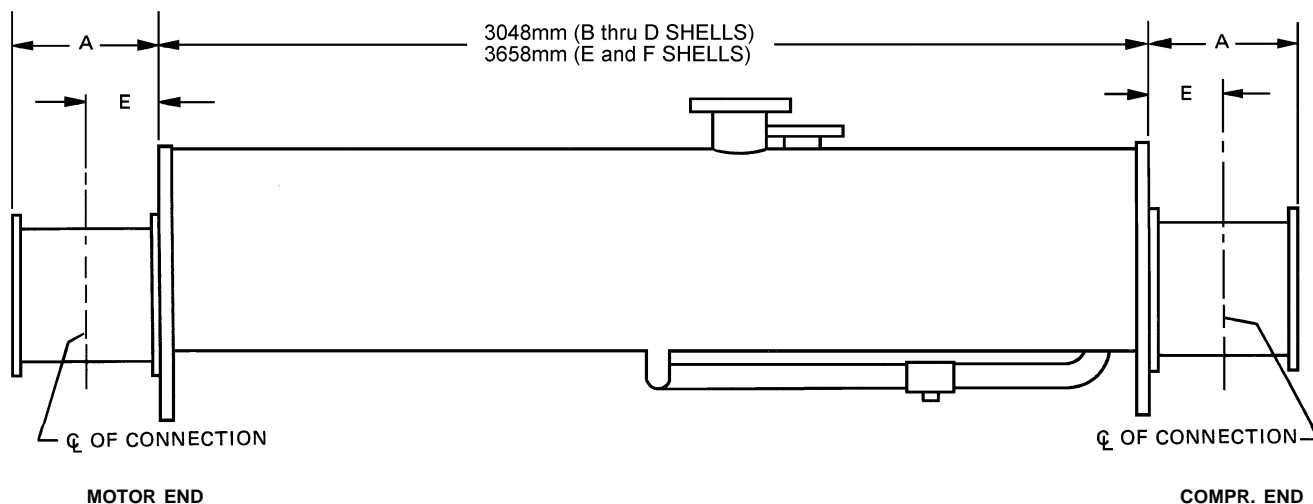

1-PASS & 3-PASS COOLERS

LD00281

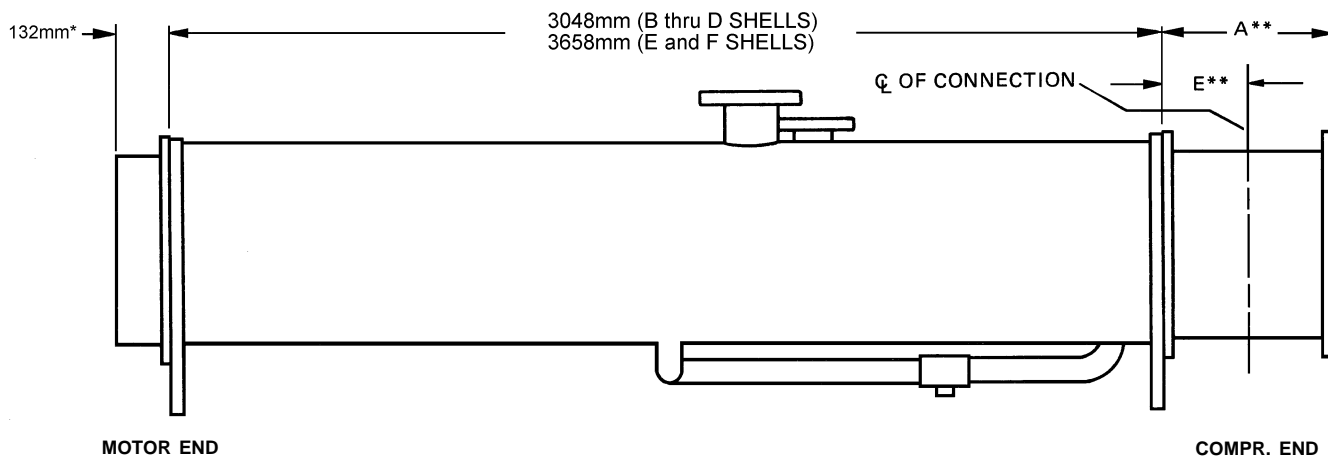

2-PASS COOLERS

LD00282

* Applies to compressor end if connections are on motor end.

** Applies to motor end if connections are on motor end.

COOLER NOZZLE SIZES

Cooler Code	Nozzle Size (In.) No. of Passes		
	1	2	3
B	8	6	4
C	10	6	6
D	12	8	6
E	12	8	6
F	12	10	8

WEIGHTS (To be added to Metric Unit Weights on pages 46-47)

Cooler Code	Shipping Weight Increase – Kg			Operating Weight Increase – Kg		
	1-Pass	2-Pass	3-Pass	1-Pass	2-Pass	3-Pass
B	252	134	255	358	178	343
C	368	190	304	549	269	434
D	396	200	349	598	273	495
E	473	276	453	761	420	698
F	582	398	514	864	466	764

Dimensions – Metric

CONDENSER NOZZLE ARRANGEMENTS – MARINE WATER BOXES R-22 & R-134a UNITS

1-PASS

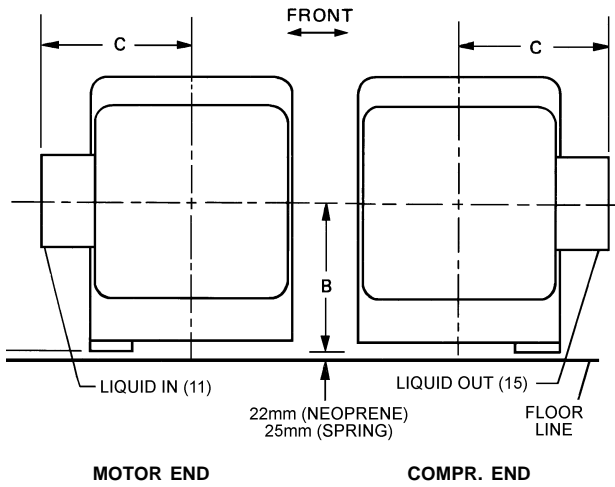

LD00283

1-PASS

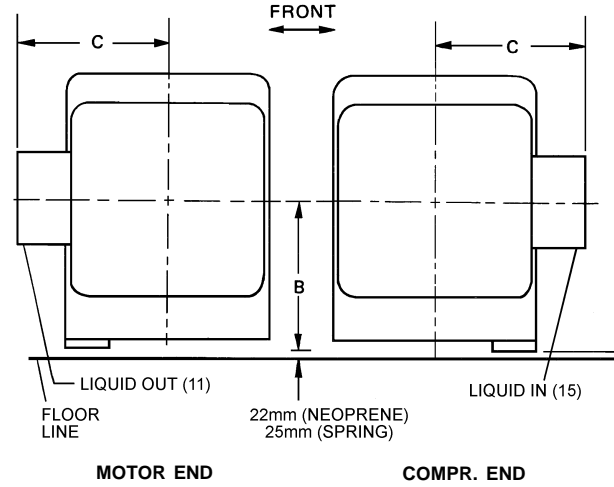

LD00284

2-PASS

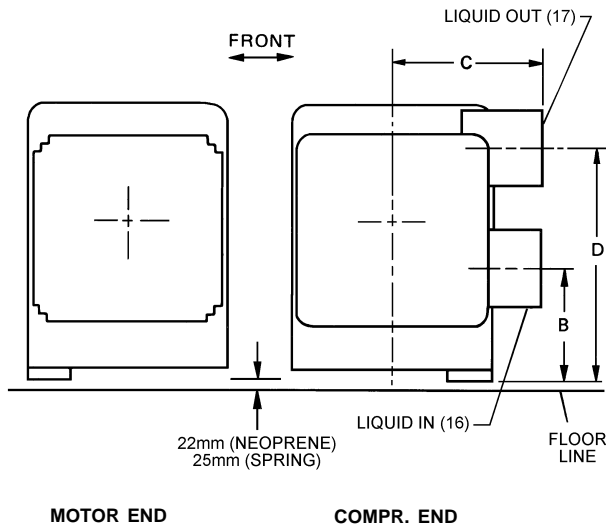

LD00285

2-PASS

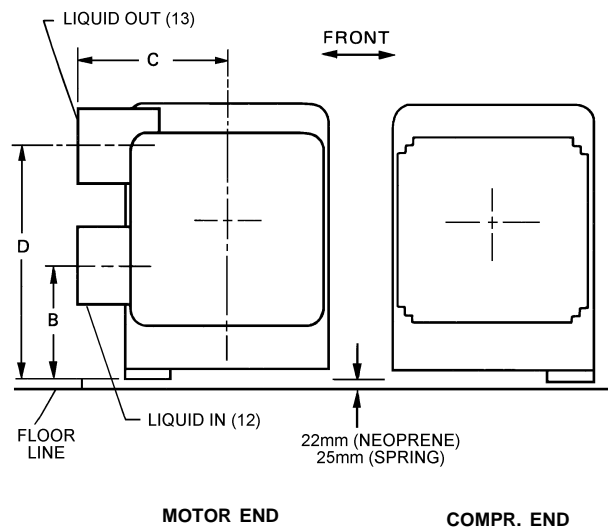

LD00286

Condenser Size	DIMENSIONS (mm)									
	1-Pass					2-Pass				
	A	B	C	D	E	A	B	C	D	E
B	394	429	448	—	197	343	283	448	575	171
C	445	425	470	—	222	394	305	470	660	197
D	508	508	537	—	254	445	381	537	806	222
E	508	508	537	—	254	445	381	537	806	222
F	533	622	638	—	267	533	470	638	972	267

CONDENSER NOZZLE ARRANGEMENTS – MARINE WATER BOXES R-22 & R-134a UNITS

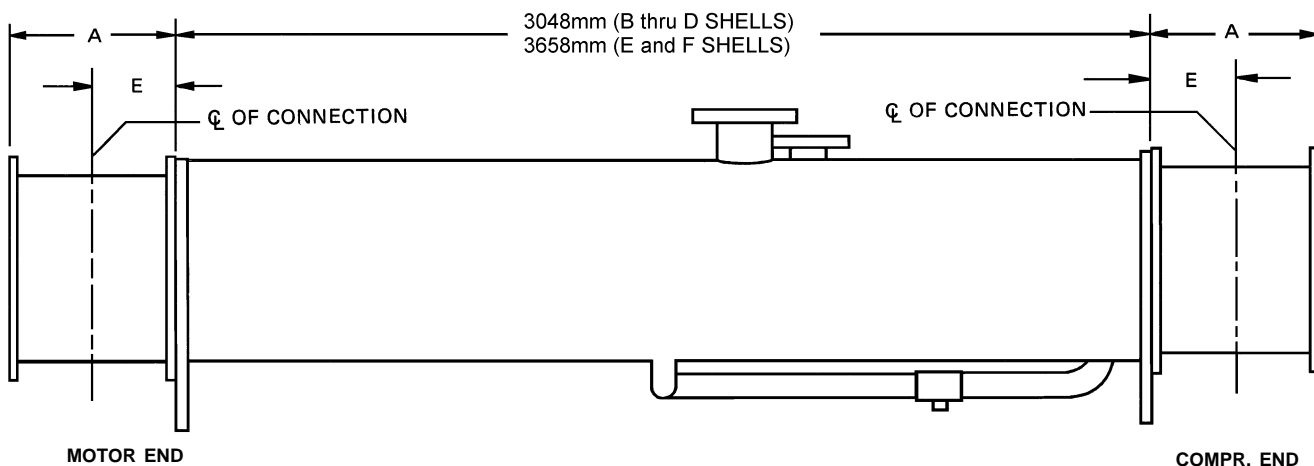

LD00287

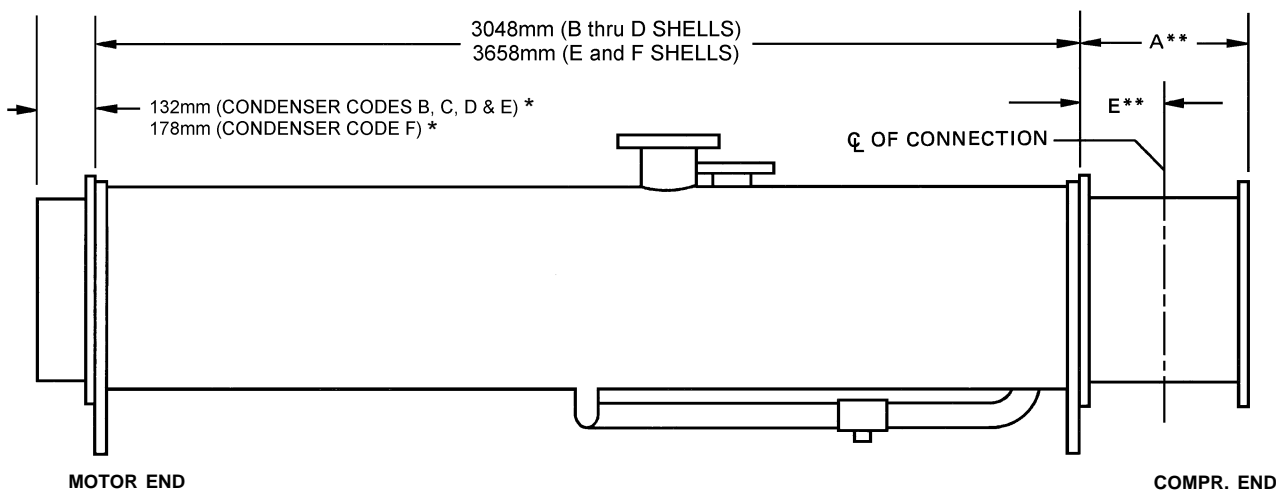

LD00288

* Applies to compressor end if connections are on motor end.

** Applies to motor end if connections are on motor end.

CONDENSER NOZZLE SIZES

Condenser Code	Nozzle Size (In.) No. of Passes	
	1	2
B	8	6
C	10	8
D	12	10
E	12	10
F	14	12

WEIGHTS (To be added to Metric Unit Weights on pages 46-47)

Condenser Code	Shipping Weight Increase – Kgs		Operating Weight Increase – Kgs	
	1-Pass	2-Pass	1-Pass	2-Pass
B	246	110	338	149
C	312	149	463	216
D	372	144	561	212
E	372	144	561	212
F	456	209	721	320

Weights – Metric

R-22 & R-134a UNITS 50 AND 60 HERTZ

SHELL CODE COOLER – COND.	COM- PRES- SOR	SHIP- PING WT. (Kgs.)	OPER- ATING WT. (Kgs.)	REFRIG- ERANT CHARGE (Kgs. R-22)	REFRIG- ERANT CHARGE (Kgs. R-134a)	SHELL CODE COOLER – COND.	COM- PRES- SOR	SHIP- PING WT. (Kgs.)	OPER- ATING WT. (Kgs.)	REFRIG- ERANT CHARGE (Kgs. R-22)	REFRIG- ERANT CHARGE (Kgs. R-134a)
BA-BA	S0	3,805	4,091	222	200	CA-DA	S2	6,059	6,697	340	306
BA-BB	S0	3,873	4,189	222	200	CA-DB	S2	6,293	7,034	340	306
BB-BA	S0	3,853	4,167	209	188	CB-DA	S2	6,164	6,846	340	306
BB-BB	S0	3,921	4,265	209	188	CB-DB	S2	6,398	7,182	340	306
BA-CA	S0	4,147	4,534	236	212	DA-CA	S2	6,030	6,568	381	343
BA-CB	S0	4,271	4,712	236	212	DA-CB	S2	6,159	6,746	381	343
BB-CA	S0	4,205	4,620	218	196	DB-CA	S2	6,200	6,808	381	343
BB-CB	S0	4,330	4,799	218	196	DB-CB	S2	6,324	6,985	381	343
CA-BA	S0	4,217	4,574	281	253	DC-CA	S2	6,362	7,054	381	343
CA-BB	S0	4,286	4,672	281	253	DC-CB	S2	6,486	7,232	381	343
CB-BA	S0	4,322	4,723	281	253	DA-DA	S2	6,599	7,314	431	388
CB-BB	S0	4,390	4,820	281	253	DA-DB	S2	6,834	7,650	431	388
CA-CA	S0	4,541	4,999	295	265	DB-DA	S2	6,745	7,533	413	371
CA-CB	S0	4,665	5,177	295	265	DB-DB	S2	6,979	7,869	413	371
CB-CA	S0	4,646	5,147	295	265	DC-DA	S2	6,902	7,909	381	343
CB-CB	S0	4,770	5,325	295	265	DC-DB	S2	7,136	7,612	381	343
BA-BA	S1	3,835	4,121	222	200	CA-CA	S3	5,606	6,066	—	278
BA-BB	S1	3,905	4,219	222	200	CA-CB	S3	5,730	6,243	—	278
BB-BA	S1	3,883	4,197	209	188	CB-CA	S3	5,711	6,213	—	278
BB-BB	S1	3,951	4,295	209	188	CB-CB	S3	5,836	6,391	—	278
BA-CA	S1	4,177	4,524	236	212	CA-DA	S3	6,157	6,796	—	306
BA-CB	S1	4,301	4,742	236	212	CA-DB	S3	6,391	7,133	—	306
BB-CA	S1	4,235	4,650	218	196	CB-DA	S3	6,261	6,946	—	306
BB-CB	S1	4,360	4,829	218	196	CB-DB	S3	6,497	7,282	—	306
CA-BA	S1	4,247	4,604	281	253	DA-CA	S3	6,122	6,656	381	343
CA-BB	S1	4,315	4,702	281	253	DA-CB	S3	6,246	6,833	381	343
CB-BA	S1	4,352	4,753	281	253	DB-CA	S3	6,287	6,895	381	343
CB-BB	S1	4,420	4,850	281	253	DB-CB	S3	6,411	7,073	381	343
CA-CA	S1	4,571	5,029	295	265	DC-CA	S3	6,450	7,141	381	343
CA-CB	S1	4,695	5,207	295	265	DC-CB	S3	6,573	7,319	381	343
CB-CA	S1	4,676	5,177	295	265	DA-DA	S3	6,687	7,401	431	388
CB-CB	S1	4,800	5,355	295	265	DA-DB	S3	6,921	7,737	431	388
BA-BA	S2	4,782	5,069	—	200	DB-DA	S3	6,832	7,620	413	371
BA-BB	S2	4,850	5,167	—	200	DB-DB	S3	7,066	7,957	413	371
BB-BA	S2	4,830	5,145	—	188	DC-DA	S3	6,989	7,862	381	343
BB-BB	S2	4,898	5,243	—	188	DC-DB	S3	7,224	8,198	381	343
BA-CA	S2	5,125	5,473	—	212	DA-CA	S4	7,742	8,277	—	336
BA-CB	S2	5,249	5,691	—	212	DA-CB	S4	7,866	8,455	—	336
BB-CA	S2	5,183	5,598	—	196	DB-CA	S4	7,907	8,517	—	336
BB-CB	S2	5,308	5,777	—	196	DB-CB	S4	8,031	8,695	—	336
CA-BA	S2	5,195	5,553	—	253	DC-CA	S4	8,070	8,764	—	336
CA-BB	S2	5,264	5,650	—	253	DC-CB	S4	8,194	8,940	—	336
CB-BA	S2	5,299	5,700	—	253	DA-DA	S4	8,307	9,023	—	376
CB-BB	S2	5,367	5,798	—	253	DA-DB	S4	8,543	9,360	—	376
CA-CA	S2	5,509	5,967	308	278	DB-DA	S4	8,453	9,243	—	363
CA-CB	S2	5,633	6,145	308	278	DB-DB	S4	8,688	9,580	—	363
CB-CA	S2	5,614	6,116	308	278	DC-DA	S4	8,611	9,486	—	336
CB-CB	S2	5,738	6,293	308	278	DC-DB	S4	8,812	9,821	—	336

R-22 & R-134a UNITS

50 AND 60 HERTZ

SHELL CODE COOLER – COND.	COM-PRES-SOR	SHIP-PING WT. (Kgs.)	OPER-ATING WT. (Kgs.)	REFRIG-ERANT CHARGE (Kgs. R-22)	REFRIG-ERANT CHARGE (Kgs. R-134a)	SHELL CODE COOLER – COND.	COM-PRES-SOR	SHIP-PING WT. (Kgs.)	OPER-ATING WT. (Kgs.)	REFRIG-ERANT CHARGE (Kgs. R-22)	REFRIG-ERANT CHARGE (Kgs. R-134a)
EA-EA	S4	9,281	9,929	635	572	EA-EA	S5	9,424	10,074	—	572
EA-EB	S4	9,573	10,316	635	572	EA-EB	S5	9,717	10,462	—	572
EB-EA	S4	9,505	10,199	612	551	EB-EA	S5	9,650	10,345	—	551
EB-EB	S4	9,767	10,586	612	551	EB-EB	S5	9,913	10,742	—	551
EC-EA	S4	9,690	10,496	590	531	EC-EA	S5	9,835	10,642	—	531
EC-EB	S4	9,979	10,882	590	531	EC-EB	S5	10,125	11,030	—	531
EA-FA	S4	10,653	11,609	689	621	EA-FA	S5	10,799	11,757	—	621
EA-FB	S4	11,202	12,334	689	621	EA-FB	S5	11,349	12,484	—	621
EB-FA	S4	10,847	11,875	689	621	EB-FA	S5	10,995	12,024	—	621
EB-FB	S4	11,394	12,601	658	592	EB-FB	S5	11,542	12,752	—	592
EC-FA	S4	11,060	12,175	658	592	EC-FA	S5	11,207	12,325	—	592
EC-FB	S4	11,609	12,898	658	592	EC-FB	S5	11,757	13,050	—	592
FA-EA	S4	10,397	11,339	—	767	FA-EA	S5	10,557	11,467	—	767
FA-EB	S4	10,722	11,727	—	767	FA-EB	S5	10,850	11,855	—	767
FB-EA	S4	10,755	11,749	—	767	FB-EA	S5	10,882	11,877	—	767
FB-EB	S4	11,017	12,137	—	767	FB-EB	S5	11,144	12,264	—	735
FC-EA	S4	10,964	12,282	—	735	FC-EA	S5	11,092	12,409	—	735
FC-EB	S4	11,404	12,669	—	735	FC-EB	S5	11,532	12,797	—	735
FA-FA	S4	11,783	12,998	907	816	FA-FA	S5	11,910	13,125	907	816
FA-FB	S4	12,332	13,724	907	816	FA-FB	S5	12,459	13,851	907	816
FB-FA	S4	12,078	13,405	907	816	FB-FA	S5	12,205	13,532	907	816
FB-FB	S4	12,624	14,131	862	776	FB-FB	S5	12,751	14,258	862	776
FC-FA	S4	12,314	13,939	862	776	FC-FA	S5	12,591	14,066	862	776
FC-FB	S4	13,013	14,662	862	776	FC-FB	S5	13,140	14,789	862	776

- NOTE:**
1. Calculate total chiller weight by adding motor weight, solid state starter weight, and marine water box weights, if applicable.
 2. Shipping weight includes refrigerant and oil charge. Operating weight includes water in tubes and water boxes.
 3. Weights based on standard tubes in coolers and condensers.

MOTOR WEIGHTS

MOTOR CODE		WEIGHT (Kgs)
60 Hz	50 Hz	
CF	5 CC	490
CG	5 CC	490
CH	5 CD	508
CJ	5 CE	508
CK	5 CF	662
CL	5 CG	689
CM	5 CH	875
CN	5 CI	875
CP	5 CJ	898
CR	5 CK	898
CS	5 CL	1,075
CT	5 CM	1,125
CU	5 CN	1,125
CV	5 CO	1,195

SOLID STATE STARTER WEIGHT

SIZE	Kgs
7L, 14L	91
26L, 33L	136

Guide Specifications

GENERAL

Furnish and install where indicated on the drawings YORK *Millennium* Rotary Screw Liquid Chilling Units(s). Each unit shall produce a capacity of _____ tons, cooling _____ GPM of _____ from _____ °F to _____ °F when supplied with _____ GPM of condenser water at _____ °F. Power input shall not exceed _____ kW with an IPLV (APLV) of _____. The cooler shall be selected for ft² °F hr/BTU fouling factor and a maximum liquid pressure drop of _____ ft. Water side shall be designed for 150 psig working pressure. The condenser shall be selected for _____ fouling factor and maximum liquid pressure drop of _____ ft. Water side shall be designed for 150 psig working pressure. Power shall be supplied to the compressor motor at _____ volts – 3-phase – (60)(50) Hertz and controls at 115 volts – 1-phase – (60)(50) Hertz.

– (or) –

Furnish and install where indicated on the drawings YORK *Millennium* Rotary Screw Liquid Chilling Units(s). Each unit shall produce a capacity of _____ kW, cooling L/S of _____ from _____ °C to _____ °C when supplied with L/S of condenser water at _____ °C. Power input shall not exceed _____ kW with an IPLV (APLV) of _____. The cooler shall be selected for _____ M² °C/W fouling factor and a maximum liquid pressure drop of _____ kPa. Water side shall be designed for 1034 kPa working pressure. The condenser shall be selected for _____ M² °C/W fouling factor and maximum liquid pressure drop of _____ kPa. Water side shall be designed for 1034 kPa working pressure. Power shall be supplied to the compressor motor at _____ volts – 3-phase – 50 Hertz and controls at 115 volts – 1-phase – 50 Hertz.

Performance shall be certified or rated in accordance with the latest edition of ARI Standard 550/590-98 as applicable. Only chillers that are listed in the ARI Certification Program for Water Chilling Packages using the vapor compression cycle are acceptable.

Each unit shall be completely factory packaged including evaporator, condenser, subcooler, oil separator, compressor, open motor, lubrication system, OptiView Control Center, Solid State Starter, refrigerant isolation valves and all interconnecting piping and wiring. The factory package shall consist of a “Leaktight” design, with no pipe thread connections that can loosen and leak over time.

All units shall ship with a full charge of refrigerant (HCFC-22 or HFC-134a) and oil. (Alternatively, the chiller shall be shipped with the compressor, control panel and oil separator removed (Form 3) or also with the shells separated (Form 7) to allow rigging into the equipment room. All units that ship disassembled shall be assembled and factory run tested prior to disassembly and shipment).

Compressor

The compressor shall be an open-drive, rotary-screw type. The compressor housing shall be of cast iron, precision machined to provide minimal clearance for the rotors. The rotors shall be manufactured from forged steel and use asymmetric profiles operating at a maximum speed of (3570 RPM/60 Hz) (2975 RPM/50 Hz). The compressor shall incorporate a complete anti-friction bearing design to reduce power and increase reliability; four separate cylindrical roller bearings to handle radial loads; and two 4-point angular contact ball bearings to handle axial loads. A spring actuated positive seating check valve shall be incorporated in the compressor housing to prevent rotor backspin during shutdown. The open-drive compressor shaft seal consists of a bellows-type spring loaded precision lapped ceramic ring, Teflon[®] static seal, and a precision lapped ceramic rotating collar. The seal cavity is maintained at intermediate pressure with its oil discharged to the oil drain from the compressor. Combining intermediate pressure with direct oil injection provides cool, non-foaming lubricant to the seal which assures a long life.

Capacity control shall be achieved by use of a slide valve to provide fully modulating control from 100% to 10% of full load. The slide valve shall be actuated by oil pressure, controlled by external solenoid valves through the OptiView Control Center. The unit shall be capable of operating with lower temperature cooling tower water during part-load operation in accordance with ARI Standard 550/590. If the unit can not operate at the minimum load, the manufacturer shall provide a hot-gas-bypass system to allow operation at 10% load, and advise the minimum load and power input of the unit at the point hot-gas-bypass is actuated.

Lubrication System

An adequate supply of oil shall be available to the compressor at all times. During start-up and coastdown, this shall be achieved by oil reservoirs in the compressor. During operation, oil shall be delivered by positive system pressure differential.

All chillers shall be provided with a single oil filter housing with isolation valves. An optional dual filter is available which allows immediate switching from one filter to the other, eliminating downtime during filter changes. The off-line oil filter must be capable of being changed during chiller operation. The chiller shall ship with a 3 micron absolute oil filter, (two filters for dual filter option) maintaining a clean oil system and ensuring superior compressor life.

A 1500W immersion oil heater shall be provided and temperature actuated to effectively remove refrigerant from the oil. Power wiring to the Control Center shall be factory installed. The oil cooler shall be refrigerant cooled and factory piped, requiring no auxiliary water or refrigerant piping in the field. An oil eductor shall be provided to automatically remove oil which may have migrated to the evaporator and return it to the compressor. The oil separator shall be of a horizontal design with no moving parts, and shall provide effective oil separation before the refrigerant enters the heat exchangers. The oil separator shall be designed, tested and stamped in accordance with ASME Boiler and Pressure Vessel Code, Section VIII – Division 1 (A.D. Merkblatter or other European Pressure Vessel Code).

Motor Driveline

The compressor motor shall be an open drip-proof, squirrel-cage, induction type operating at 3570 RPM (2975 RPM for 50 Hz operation).

The open motor shall be provided with a D-flange, bolted to a cast-iron adaptor mounted on the compressor to allow the motor to be rigidly coupled to the compressor to provide factory alignment of motor and compressor shafts.

Motor drive shaft shall be directly connected to the compressor shaft with a flexible disc coupling. Coupling shall have all metal construction with no wearing parts to assure long life, and no lubrication requirements to provide low maintenance. For units utilizing remote electromechanical starters, a large steel terminal box with gasketed front access cover shall be provided for field connected conduit. Overload/overcurrent transformers shall be furnished with all units. (For units furnished with factory packaged Solid State Starters, refer to the “Options” section.)

Evaporator

Evaporator shall be of the shell-and-tube, flooded type designed for 300 psig (2069 KPa) working pressure on the refrigerant side. Shell shall be fabricated from rolled carbon steel plate with fusion welded seams; have carbon steel tube sheets, drilled and reamed to accommodate the tubes; and intermediate tube supports spaced no more than four feet apart. The refrigerant side shall be designed, tested and stamped in accordance with ASME Boiler and Pressure Vessel Code, Section VIII – Division 1 (A.D. Merkblatter or other European Pressure Vessel Code). When required by the refrigeration safety code, the vessel shall have a refrigerant relief device(s) set at 300 psig (2069 KPa). Tubes shall be high-efficiency, internally enhanced type. Each tube shall be roller expanded into the tube sheets providing a leak-proof seal, and be individually replaceable. Water velocity through the tubes shall not exceed 12 FPS (3.6 m/s). Liquid level sight glass shall be located on the side of the shell to aid in determining proper refrigerant charge.

Water boxes shall be removable to permit tube cleaning and replacement. Stubout water connections having Victaulic grooves shall be provided. Water boxes shall be designed for 150 psig (1034 KPa) design working pressure and be tested at 225 psig (1551 KPa). Vent and drain connections with plugs shall be provided on each water box.

Condenser

Condenser shall be of the shell-and-tube type, designed for 300 psig (2069 KPa) working pressure on the refrigerant side. Shell shall be fabricated from rolled carbon steel plate with fusion welded seams; have carbon steel tube sheets, drilled and reamed to accommodate the tubes; and intermediate tube supports spaced no more than four feet apart. A refrigerant subcooler shall be provided for improved cycle efficiency. The refrigerant side shall be designed, tested and stamped in accordance with ASME Boiler and Pressure Vessel Code, Section VIII – Division 1 (A.D. Merkblatter or other European Pressure Vessel Code). When required by the refrigeration safety code, the vessel shall have a refrigerant relief device(s) set at 300 psig (2069 KPa). Tubes shall be high-efficiency, internally enhanced type. Each tube shall be roller expanded into the tube sheets providing a leak-proof seal, and be individually replaceable. Water velocity through the tubes shall not exceed 12 FPS.

Guide Specifications

Water boxes shall be removable to permit tube cleaning and replacement. Stubout water connections having Victaulic grooves shall be provided. Water Boxes shall be designed for 150 psig (1034 KPa) design working pressure and be tested at 225 psig (1551 KPa). Vent and drain connections with plugs shall be provided on each water box.

Refrigerant System

The YS chiller is equipped with a refrigerant metering device consisting of a fixed orifice and solenoid valve controlled via the OptiView Control Center. This control ensures proper refrigerant flow to the evaporator over a wide range of operating conditions, including thermal storage applications and chilled water reset. Valve operation is programmable and can be customized for a specific application via the OptiView Control Center keypad.

The condenser shell shall be capable of storing the entire system refrigerant charge during servicing. Isolation from the rest of the system shall be by manually operated isolation valves located at the inlet and outlet of the condenser. Additional valves shall be provided to facilitate removal of refrigerant charge from the system.

OPTIVIEW CONTROL CENTER

General – The chiller shall be controlled by a stand-alone microprocessor based control center. The chiller control panel shall provide control of chiller operation and monitoring of chiller sensors, actuators, relays and switches.

Control Panel – The control panel shall include a 10.4-in. diagonal color liquid crystal display (LCD) surrounded by "soft" keys which are redefined based on the screen displayed at that time. This shall be mounted in the middle of a keypad interface and installed in a locked enclosure. The screen shall detail all operations and parameters, using a graphical representation of the chiller and its major components. Panel verbiage shall be available in other languages as an option with English always available. Data shall be displayed in either English or Metric units. Smart Freeze Point Protection shall run the chiller at 36°F (2.22°C) leaving chilled water temperature, and not have nuisance trips on low water temperature. The sophisticated program and sensor shall monitor the chiller water temperature to prevent freeze-up. When needed, Hot Gas Bypass is available as an option. The panel shall display countdown timer messages so the operator knows when functions are starting and stopping. Every programmable point shall have a pop-up screen with the allowable ranges, so that the chiller can not be programmed to operate outside of its design limits.

The control panel shall be provided with a thermal ice storage control mode to enhance system performance during ice building operation. In the thermal storage control mode, the chiller shall stay at 100% load until the setpoint shutdown temperature is reached. To add greater operating flexibility and eliminate unnecessary chiller cycling, two different Low Water (Liquid) Temperature Restart Thresholds shall be programmable, one for the ice mode and one for the standard cooling mode. The chiller shall have the capability to remain in the standard control mode for temperatures between 20 to 70°F (-6.7 to 21.1°C) for applications involving a process cooling duty that requires leaving chilled liquid temperature setpoint control.

The chiller control panel shall also provide:

1. System operating information including:
 - a. Return and leaving chilled water temperature
 - b. Return and leaving condenser water temp.
 - c. Evaporator and condenser saturation temp.
 - d. Oil pressure at compressor and oil filter differential
 - e. Percent motor current
 - f. Evaporator and condenser saturation temp.
 - g. Compressor discharge temperature
 - h. Oil temperature
 - i. Percent slide valve position
 - j. Operating hours
 - k. Number of unit starts
2. Digital programming of setpoints through the universal keypad including:
 - a. Leaving chilled water temperature
 - b. Percent current limit
 - c. Pull-down demand limiting
 - d. Six-week schedule for starting and stopping the chiller, pumps and tower
 - e. Remote reset temperature range
3. Status messages indicating:
 - a. System ready to start
 - b. System running
 - c. System coastdown
 - d. System safety shutdown-manual restart
 - e. System cycling shutdown-auto restart
 - f. System prelube
 - g. Start inhibit
4. The text displayed within the system status and system details field shall be displayed as a color coded message to indicate severity: red for safety fault,

- orange for cycling faults, yellow for warnings, and green for normal messages.
5. Safety shutdowns enunciated through the display and the status bar, and consist of system status, system details, day, time, cause of shutdown, and type of restart required. Safety shutdowns with a fixed speed drive shall include:
 - a. Evaporator - low pressure
 - b. Evaporator - low pressure - smart freeze
 - c. Evaporator - transducer or leaving liquid probe
 - d. Evaporator - transducer or temperature sensor
 - e. Condenser - high pressure contacts open
 - f. Condenser - high pressure
 - g. Condenser - pressure transducer out of range
 - h. Auxiliary safety - contacts closed
 - i. Discharge - high temperature
 - j. Discharge - low temperature
 - k. Oil - high temperature
 - l. Oil - low differential pressure
 - m. Oil - low differential seal pressure
 - n. Oil or condenser transducer error
 - o. Oil - clogged filter
 - p. Oil - high pressure
 - q. Oil - separator - low level
 - r. Control panel - power failure
 - s. Watchdog - software reboot
 - 5.1. Safety shutdowns with a Solid State Starter (LCSSS) shall include:
 - a. Shutdown - requesting fault data...
 - b. High instantaneous current
 - c. High phase (X) heatsink temperature - running
 - d. 105% motor current overload
 - e. Motor or starter - current imbalance
 - f. Phase (X) shorted SCR
 - g. Open SCR
 - h. Phase rotation
 6. Cycling shutdowns enunciated through the display and the status bar, and consisting of system status, system details, day, time, cause of shutdown, and type of restart required.

Cycling shutdowns with a fixed speed drive shall include:

 - a. Multiunit cycling - contacts open
 - b. System cycling - contacts open
 - c. Control panel - power failure
 - d. Leaving chilled liquid - low temperature
 - e. Leaving chilled liquid - flow switch open
 - f. Condenser - flow switch open
 - g. Motor controller - contacts open
 - h. Motor controller - loss of current
 - i. Power fault
 - j. Control panel - schedule
 - 6.1 Cycling shutdowns with a Solid State Starter (LCSSS) shall include:
 - a. Initialization failed
 - b. Serial communications
 - c. Requesting fault data
 - d. Stop contacts open
 - e. Power fault
 - f. Low phase (X) temperature sensor
 - g. Run signal
 - h. Invalid current scale selection
 - i. Phase locked loop
 - j. Low supply line voltage
 - k. High supply line voltage
 - l. Logic board processor
 - m. Logic board power supply
 - n. Phase loss
 7. Security access to prevent unauthorized change of setpoints, to allow local or remote control of the chiller, and to allow manual operation of the prerotation vanes and oil pump. Access shall be through ID and password recognition, which is defined by three different levels of user competence: view, operator, and service.
 8. Trending data with the ability to customize points of once every second to once every hour. The panel shall trend up to 6 different parameters from a list of over 140, without the need of an external monitoring system.
 9. The operating program stored in non-volatile memory (EPROM) to eliminate reprogramming the chiller due to AC power failure or battery discharge. Programmed setpoints shall be retained in lithium battery-backed RTC memory for a minimum of 11 years with power removed from the system.
 10. A fused connection through a transformer in the compressor motor starter to provide individual over-current protected power for all controls.
 11. A numbered terminal strip for all required field interlock wiring.
 12. An RS-232 port to output all system operating data, shutdown/cycling message, and a record of the last 10 cycling or safety shutdowns to a field-supplied

Guide Specifications

printer. Data logs to a printer at a set programmable interval. This data can be preprogrammed to print from 1 minute to 1 day.

13. The capability to interface with a building automation system to provide:
 - a. Remote chiller start and stop
 - b. Remote leaving chiller liquid temperature adjust
 - c. Remote current limit setpoint adjust
 - d. Remote ready to start contacts
 - e. Safety shutdown contacts
 - f. Cycling shutdown contacts
 - g. Run contacts

COMPRESSOR MOTOR STARTER (OPTION, 200 - 600V)

The chiller manufacturer shall furnish a reduced-voltage Solid State Starter for the compressor motor. Starter shall be factory-mounted and wired on the chiller. The starter shall provide, through the use of silicon controlled rectifiers, a smooth acceleration of the motor without current transitions or transients. The starter enclosure shall be NEMA 1, with a hinged access door with lock and key. Electrical lugs for incoming power wiring shall be provided.

Standard features include: digital readout at the OptiView Control Center of the following:

Display Only:

- 3-phase voltage A, B, C
- 3-phase current A, B, C
- Input power (kW)
- kW Hours
- Starter Model
- Motor Run (LED)
- Motor Current % Full Load Amps
- Current Limit Setpoints
- Pulldown Demand Time Left

Programmable:

- Local Motor Current Limit
- Pulldown Demand Limit
- Pulldown Demand Time

Other features include: low-line voltage, 115-volt control transformer; three-leg sensing overloads; phase rotation and single-phase failure protection; high temperature safety protection, motor current imbalance and undervoltage safeties; open and close SCR protection; momentary power interruption protection. The LCSSS is cooled by a closed loop, fresh water circuit consisting of a water-to-water heat exchanger and 1/25 HP circulating pump. All interconnecting water piping is factory installed and rated for 150 PSIG working pressure. **Optional** unit-mounted circuit breaker includes ground fault protection and provides 65,000 amp. Short circuit withstand rating in accordance with UL Standard 508. A non-fused disconnect switch is also available. Both options are padlockable.

REMOTE ELECTRO-MECHANICAL COMPRESSOR MOTOR STARTER (OPTIONAL)

A remote electro-mechanical starter of the R-1051 type shall be furnished for each compressor motor. The starter shall be furnished in accordance with the chiller manufacturer's starter specifications and as specified elsewhere in these specifications.

PORTABLE REFRIGERANT STORAGE/RECYCLING SYSTEM

A portable, self-contained refrigerant storage/recycling system shall be provided consisting of a refrigerant compressor with oil separator, storage receiver, water cooled condenser, filter drier and necessary valves and hoses to remove, replace and distill refrigerant. All necessary controls and safety devices shall be a permanent part of the system.

START-UP AND OPERATOR TRAINING

The chiller manufacturer shall include the services of a factory-trained, field service representative to supervise the final leak testing, charging and the initial start-up and concurrent operator instruction.

Metric Conversion Tables

MEASUREMENT	MULTIPLY THIS ENGLISH VALUE	BY	TO OBTAIN THIS METRIC VALUE
CAPACITY	TONS REFRIGERANT EFFECT (ton)	3.516	KILOWATTS (kW)
POWER	KILOWATTS (kW)	NO CHANGE	KILOWATTS (kW)
	HORSEPOWER (hp)	0.7457	KILOWATTS (kW)
FLOW RATE	GALLONS / MINUTE (gpm)	0.0631	LITERS / SECONDS (L/s)
LENGTH	FEET (ft)	304.8	MILLIMETERS (mm)
	INCHES (in)	25.4	MILLIMETERS (mm)
WEIGHT	POUNDS (lb)	0.4536	KILOGRAMS (kg)
VELOCITY	FEET / SECOND (fps)	0.3048	METERS / SECOND (m/s)
PRESSURE DROP	FEET OF WATER (ft)	2.989	KILOPASCALS (k Pa)
	POUNDS / SQ. INCH (psi)	6.895	KILOPASCALS (k Pa)

Temperature

To convert degrees Fahrenheit (°F) to degrees Celsius (°C), subtract 32° and multiply by 5/9 or 0.5556.

To convert a temperature range (i.e., 10°F or 12°F chilled water range) from Fahrenheit to Celsius, multiply by 5/9 or 0.5556.

Efficiency

In the English I-P system, chiller efficiency is measured in kW / ton:

$$\text{kW / ton} = \frac{\text{kW input}}{\text{tons refrigerant effect}}$$

In the SI Metric system, chiller efficiency is measured in Coefficient of Performance (COP).

$$\text{COP} = \frac{\text{kW refrigeration effect}}{\text{kW input}}$$

kW / ton and COP are related as follows:

$$\text{kW / ton} = \frac{3.516}{\text{COP}}$$

$$\text{COP} = \frac{3.516}{\text{kW / ton}}$$

Integrated Part Load Value (IPLV)

In the English I-P system, IPLV is calculated by the following formula. A full explanation is shown on page 4:

$$\text{IPLV}^* = \frac{1}{\frac{0.01}{A} + \frac{0.42}{B} + \frac{0.45}{C} + \frac{0.12}{D}}$$

Where: A = kW / ton at 100% Load @ 85°F ECFT
 B = kW / ton at 75% Load @ 75°F ECFT
 C = kW / ton at 50% Load @ 65°F ECFT
 D = kW / ton at 25% Load @ 65°F ECFT

In SI Metric, the formula is:

$$\text{IPLV}^* = 0.01A + 0.42B + 0.45C + 0.12D$$

Where: A = COP at 100% Load @ 29.4°C ECFT
 B = COP at 75% Load @ 23.9°C ECFT
 C = COP at 50% Load @ 18.3°C ECFT
 D = COP at 25% Load @ 18.3°C ECFT

* NOTE: The Non-Standard Part-Load Value (NPLV) uses the IPLV formula with the following exceptions: the ECFT for part-load points varies linearly from the selected EFT to 65°F (18.3°C) from 100% to 50% loads, and fixed at 65°F (18.3°C) for 50% to 0% loads.

FOULING FACTOR

ENGLISH I-P (ft ² °F hr/BTU)	EQUIVALENT SI METRIC (M ² K/kW)
0.0001	0.018
0.00025	0.044
0.0005	0.088
0.00075	0.132



Proud Sponsor
of the 2000
U.S. Olympic Team

36USC380