



Millennium[®] Air Cooled Screw Liquid Chillers (STYLE G)



28971AR



130 - 200 TONS



Metric Conversions

125 - 420 TONS
(439 - 1460 kW)
60 Hz



200, 230, 380,
460, & 575 Models

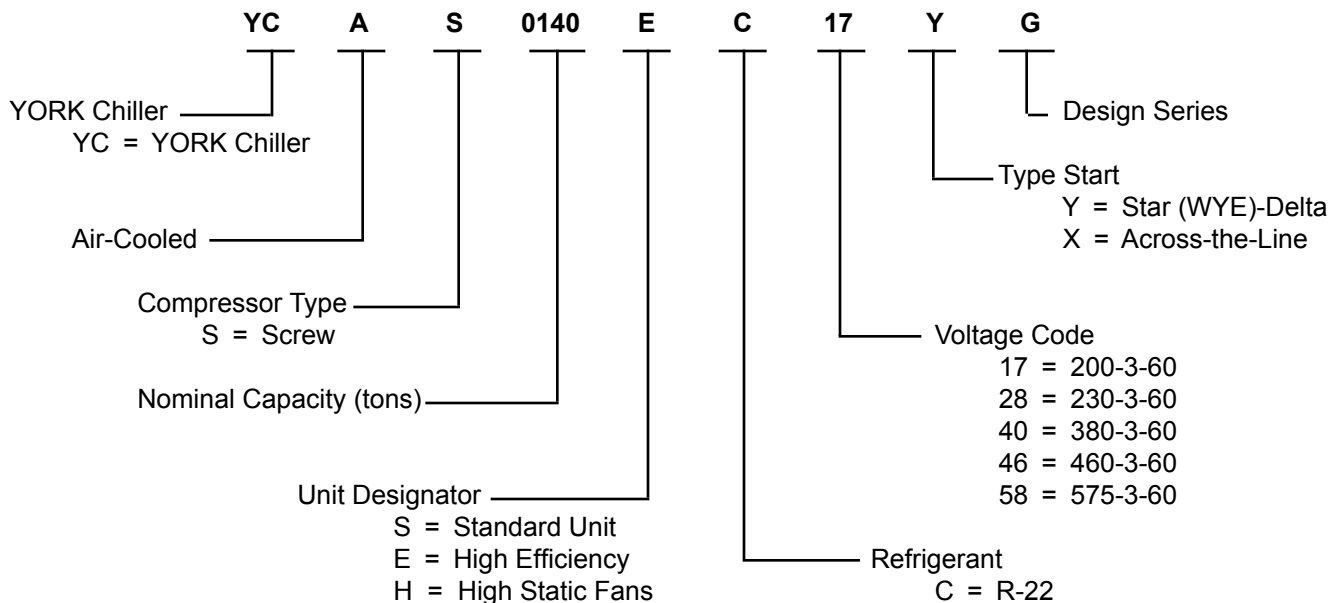

TABLE OF CONTENTS

<i>Introduction</i>	3
<i>Specifications</i>	4
<i>Accessories and Options</i>	7
<i>Temperatures and Flows</i>	10
<i>Water Pressure Drop</i>	12
<i>Ratings – English Units - R22</i>	14
<i>Ratings – SI Units - R22</i>	26
<i>Physical Data</i>	32
<i>Operating Weights – Aluminum Fin Coils</i>	60
<i>Isolator Selection – Aluminum Fin Coils</i>	61
<i>Operating Weights – Copper Fin Coils</i>	62
<i>Isolator Selection – Copper Fin Coils</i>	63
<i>Isolator Details</i>	64
<i>Electrical Data</i>	66
<i>Electrical Data</i>	68
<i>Electrical Notes</i>	74
<i>Electrical Notes (Continued)</i>	75
<i>Power Connection Options</i>	76
<i>Typical Control Wiring</i>	80
<i>Application Data</i>	82
<i>Guide Specifications</i>	83

NOMENCLATURE

The Model Number denotes the following characteristics of the unit:



YORK Millennium® Air Cooled Screw Liquid Chillers



YORK Millennium Air Cooled Screw Compressor machines are the state-of-the-art in air-cooled chillers, providing chilled fluids for all air conditioning applications. Completely self-contained and designed for outdoor installation, these chillers employ new, low noise, energy efficient, serviceable, semi-hermetic screw compressors designed and manufactured specifically for this new product line. These compressors, with reliable twin-screw technology, are ideally matched to evaporators and condensers optimally configured for superior heat transfer and unit efficiency. Condenser coils are arranged to maximize airflow using full airfoil, high efficiency, low noise fans driven by low energy motors. The screw compressors, high efficiency evaporator, enhanced heat transfer condensers, and weather tight power and microprocessor control centers are mounted on a bolted, fully galvanized and powder painted, all steel base, for unsurpassed reliability and performance.

Specifications

These YORK air cooled chillers are shipped as a complete factory package. Each unit is completely assembled with all interconnecting refrigerant piping and internal wiring, ready for field installation:

COMPLETE FACTORY PACKAGE

- Each compressor is installed on its own independent refrigerant circuit, which is factory pressure tested, evacuated, then fully charged with refrigerant and oil.
- After assembly, an operational test is performed with water flowing through the cooler to ensure each circuit operates correctly.
- Cabinet and base frame are constructed of formed heavy gauge, galvanized steel.
- All external structural parts are covered with architecturally neutral "Desert Sand" (Munsell #10YR6-2) baked-on enamel powder paint. This provides a finish which, when subjected to ASTM B117, 500 hour, 5% salt spray conditions, shows breakdown of less than $\frac{1}{8}$ " either side of a scribed line (equivalent to ASTM D1654 rating of "6").
- Design is in accordance with applicable sections of ASME Pressure Vessel Code, NFPA 70 (National Electrical Code), U.L. and cU.L. Standards, and ASHRAE/ANSI-15 Safety Code for Mechanical Refrigeration.
- Units are Rated and Certified in accordance with ARI Standard 550/590-98.
- All exposed power wiring routed through liquid-tight, non-metallic conduit.

SEMI-HERMETIC YORK SCREW COMPRESSORS

- An ideal synergy of expertise, sister division YORK Refrigeration Compressor Engineers as integral members on YORK Engineered Systems' Chiller Design Team, has resulted in a world class compressor with unequalled performance.
- Continuous function, microprocessor controlled, 3-way proportional Capacity Control Valve provides regulated output pressure independent of valve input pressure for a stable, smooth, and precise match of compressor capacity to cooling load to 10% of chiller capacity.
- Automatic spring return of capacity control valve to minimum load position ensures compressor starting at minimum motor load. Internal discharge check to prevent rotor backspin upon shut-down.
- Acoustically tuned, internal discharge gas muffler eliminates objectionable noise at the source, while optimizing flow for maximum performance.

- Reliable suction gas cooled, high efficiency, accessible hermetic motor with APT2000 type magnet wire and redundant overload protection using both thermistor and current overload protection.
- Suction gas screen and serviceable, 0.5 micron full flow oil filter within the compressor housing.
- Some models equipped with tuned port economizer as appropriate for enhanced capacity and superior efficiency.
- Cast iron compressor housing precisely machined for optimal clearances and superb efficiency. Entire compressor, from suction to discharge has a Design Working Pressure of 450 PSIG (31 bar).
- 350W compressor body cartridge heater.

CONDENSER SECTION

- Condenser Fans with low noise, full airfoil cross section for maximum efficiency, statically and dynamically balanced for low vibration operation, and positioned in extended, formed steel orifices for low sound and maximum efficiency.
- Condenser fan motors are high efficiency, direct drive, 6-pole, 3-phase, Class-"F", current overload protected, totally enclosed (TEAO) type with double sealed, permanently lubricated, ball bearings.
- Fin and tube condenser coils of seamless, internally enhanced, high condensing coefficient, corrosion resistant copper tubes arranged in staggered rows and mechanically bonded to corrosion resistant aluminum alloy fins with full height fin collars. Design working pressure is 450 PSIG (31 bar).

EVAPORATOR

- High efficiency, direct-expansion type cooler with refrigerant in tubes and chilled liquid through the baffled shell. Independent circuits provided for each compressor.
- Design working pressure of the shell waterside is 150 PSIG (10.3 bar), and 350 PSIG (24 bar) for the refrigerant side. Constructed and tested in accordance with applicable sections of ASME Pressure Vessel Code, Section VIII, Division (1). Water side exempt per paragraph U-1, (c), (6).
- Water baffles fabricated from galvanized steel to resist corrosion. Removable heads allow access to internally-enhanced, seamless, copper tubes. Water vent and drain connections included.
- Cooler equipped with thermostatically controlled heater for protection to -20°F (-29°C) ambient, and insulated with $\frac{3}{4}$ " (19mm) flexible, closed-cell foam ($k = 0.25$).

REFRIGERANT CIRCUIT

- Independent refrigerant circuits per compressor, each using copper refrigerant pipe formed on computer controlled bending machines. This eliminates over 60% of system piping brazed joints as compared to designs that use fittings, resulting in a highly reliable and leak resistant system.
- Liquid line components include: manual shut-off valve with charging port, high adsorption removable core filter-drier, solenoid valve, sight glass with moisture-indicator, and reliable electronic expansion valves for R22 and a thermostatic expansion valves for remote barrel units.
- Economizer is a refrigerant to refrigerant, compact plate-type heat exchanger to maximize chiller capacity and efficiency by subcooling liquid refrigerant delivered to the cooler expansion valve. Constructed of corrosion resistant stainless steel plates formed to induce turbulent flow and enhance heat transfer, then oven brazed and pressure tested for reliability. Designed and constructed in accordance with ASME and TÜV for 450 PSIG (31 bar). U.L./CSA listed.
- Suction and discharge lines provided with manual compressor shutoff service valves (Factory Option). Suction line equipped with closed-cell insulation.
- Oil separators with Design Working Pressure of 450 PSIG (31 bar) and U.L. listing are high efficiency, augmented aerosol impingement type to maximize oil extraction without fragile media to break down. An oil charging valve is included with each refrigerant circuit.
- Oil cooling provided by dedicated air cooled finned tube type heat exchanger located in the condenser section of the machine.

MICROPROCESSOR CONTROLS

- Controls housed in a powder painted steel cabinet enclosure, equivalent to NEMA 3R/12 (IP55), with hinged, latched, and gasket sealed, door.
- Liquid crystal 40 character display with text provided on two lines and light emitting diode backlighting for outdoor viewing.
- Color coded, 32 button, sealed keypad with sections for Display, Entry, Setpoints, Clock, Print, Program and Unit On/Off.
- Standard controls include: brine chilling or thermal storage, automatic pump down, run signal contacts, demand load limit from external building automation system input, remote liquid temperature reset input, unit alarm contacts, evaporator pump control, automatic reset after power failure, automatic system optimization to match operating conditions, software stored in non-volatile memory (EPROM) to eliminate chiller failure due to AC power failure. Programmed

setpoints retained in lithium battery backed RTC memory for a minimum 5 years.

- **Display** – In English (°F and PSIG) or Metric (°C and Bars) units, and for each circuit:
 - ◆ Return and leaving chilled liquid, and ambient temperature.
 - ◆ Day, date and time. Daily start/stop times. Holiday and Manual Override status.
 - ◆ Compressor operating hours and starts. Automatic or manual lead/lag. Lead compressor identification.
 - ◆ Run permissive status. No cooling load condition. Compressor run status.
 - ◆ Anti-recycle timer and anti-coincident start timer status per compressor.
 - ◆ Suction (and suction superheat), discharge, and oil pressures and temperatures per System.
 - ◆ Percent full load compressor motor current per phase and average per phase. Compressor capacity control valve input steps.
 - ◆ Cutout status and set-points for: supply fluid temperature, low suction pressure, high discharge pressure and temperature, high oil temperature, low and high ambient, phase rotation safety, and low leaving liquid temperature.
 - ◆ Unloading limit set-points for high discharge pressure and compressor motor current.
 - ◆ Liquid pull-down rate sensitivity (0.5°F to 5°F/minute in 0.1°F increments).
 - ◆ Status of: evaporator heater, condenser fans, load and unload timers, chilled water pump.
 - ◆ “Out of range” message.
 - ◆ Up to 6 fault shut down conditions.
 - ◆ Standard Display Language is English, French, and Spanish.
- **Entry** – Enter set point changes, cancel inputs, advance day, change AM/PM.
- **Setpoints** – Chilled liquid temperature, chilled liquid range, remote reset temperature range.
- **Clock** – Time, daily or holiday start/stop schedule, manual override for servicing.
- **Print** – Operating data or system fault shutdown history for last six faults, and software version. Printouts through an RS-232 port via a separate printer (by others).
- **Program** –
 - ◆ Low leaving liquid temperature cutout, 300 to 600 second anti-recycle timer, lag compressor start time delay, and average motor current unload point. Liquid temperature setpoint reset signal from **YORK ISN** or building automation system

Specifications (Continued)

(by others) via:

- ❖ Pulse width modulated (PWM) input for up to 40°F (22°C) total reset as standard.
- ❖ *Optional* Building Automation System interface input card for up to 40°F (22°C) reset using a: 4 to 20 milliamp, 0 to 10 VDC input, or discrete reset input. [**NOTE:** The Standard MicroPanel can be directly connected to a YORK ISN Building Automation System via the standard onboard RS485 communication port. This Option also provides open system compatibility with other communications networks (BACNET™ & LONMARK™) via interface through standard onboard 485 or 232 port and an external **YorkTalk Translator.**]
- ◆ Additional functions (password protected) for programming by a qualified service technician:
 - ❖ Cut-outs for low and high ambient, low suction pressure, high discharge pressure, high oil temperature.
 - ❖ Refrigerant type.
 - ❖ High discharge pressure unload setpoint.
 - ❖ Fan control discharge pressure set point.
 - ❖ Fan ON/OFF pressure differential.
 - ❖ Compressor motor current percent limit.
- ◆ The Standard unit controls permit operation down to 0°F (-18°C) outdoor ambient temperature.

POWER PANEL

- Power panel housed in NEMA 3R/12 (IP55) rain/dust tight, powder painted steel cabinets with hinged, latched, and gasket sealed outer doors equipped with wind struts for safer servicing. Two motor control center cabinets are provided, with independent doors and separated by a steel barrier panel.
- Current transformers sense each phase, as an input to the microprocessor, to protect compressor motors from damage due to: low input current, high input current, unbalanced current, single phasing, phase reversal, and compressor locked rotor.
- Control Current Terminal Strip provides power input terminals to field provided power input (models 0130 - 0230). Control circuit transformer provides 115V60/1Ø power to the unit control system for models 0250 - 0440. Includes factory primary wiring from Circuit #2 Motor Control Center via lockable disconnect on panel door separate from the motor control centers, and secondary wiring supply to the 24V, fused Microprocessor panel transformer.
- Individual fan motor contactors & external overloads per condenser fan motor.
- Exposed compressor and fan motor power wiring routed through liquid tight conduit.

Accessories and Options

- **CONTROL CIRCUIT TERMINAL STRIP – (Models 0250 - 0440)** – Provides power input terminals for field provided power input in lieu of factory mounted control circuit transformer. 115V, 1Ø Control Circuit Power Terminal Strip located in the Microprocessor Panel to accept a field provided control power circuit with appropriate branch circuit protection in accordance with applicable Local and National codes. Provides unit control circuit power, including supply to the 24V, fused Microprocessor panel transformer.
- **CONTROL CIRCUIT TRANSFORMER (Models 0130 - 0230)** - Control circuit transformer provides 115V60/1Ø power to the unit control system.
- **BUILDING AUTOMATION SYSTEM (BAS) INTERFACE** – Provides means to reset the leaving chilled liquid temperature or percent full load amps (current limiting) from the BAS (Factory Mounted):
 - ◆ Printed circuit board to accept 4 to 20 milliamp, 0 to 10 VDC, or dry contact closure input from the BAS.
 - ◆ A YORK ISN Building Automation System can provide a Pulse Width Modulated (PWM) signal direct to the standard control panel via the standard on-board RS485 port.
- **PRIMARY CHILLER POWER CONNECTIONS** – See Electrical Data on pages 66 through 74 for specific voltage and options availability. Separate external branch circuit protection and disconnecting means must be supplied by others in accordance with applicable Local and National codes. (Factory Mounted)
 - ① **Multiple Point Supply – Standard** field power wiring connection on all models is Multiple Point Power Connection to factory provided Terminal Blocks. Two field supplied electrical power circuits with appropriate branch circuit protection provide power to each of two motor control center cabinets, located adjacent to each other at one end of the chiller. Each cabinet contains starter elements for one or two compressors and their associated fan motor starters.

Optional to the Terminal Blocks for field power connection are Non-Fused Disconnects with external lockable handles, or (on two compressor machines only) Circuit Breakers with external lockable handles. Also *Optional* (on 3 & 4 compressor machines equipped with multiple point power supply) are individual system circuit breakers per each compressor with external lockable handles.
 - ② **Single-Point Supply – Optional** to the Multiple Point power connection configurations are Single-Point Supply arrangements. A wide variety of these single-point *Options* are offered to satisfy most any customer connection requirement:
 - ◆ **Single-Point with Individual System Breakers** –These options consist of field connection to either a unit mounted Terminal Block, or a Non-Fused Disconnect Switch with external, lockable handle (in compliance with Article 440-14 of N.E.C., to isolate unit power supply for service). Factory wiring is provided from the Terminal Block or Disconnect Switch to factory supplied Individual System Circuit Breakers with external, lockable handles in each of the two compressor motor control centers.
 - ◆ **Single-Point Supply** – Also optional (on two compressor machines only) are Single-Point Supply configurations for field connection of a single electrical circuit to: Terminal Block, Non-Fused Disconnect Switch with lockable external handle (in compliance with Article 440-14 of N.E.C., to isolate unit power supply for service), or Circuit Breaker with lockable external handle. Factory wiring is provided from the Terminal Block, Disconnect Switch, or Breaker directly to the starter components in each of the two compressor motor control centers.
- **STAR (WYE)-DELTA COMPRESSOR MOTOR STARTER** – Provides smooth starting and approximately 65% reduced inrush current compared to across-the-line type start. Two compressor units equipped with any of the Single-Point Power connection options and Star-Delta starters must also be equipped with Individual System Circuit Breakers option. Three and four compressor units with Star-Delta starters must also include Individual System Circuit Breakers option. (Factory Mounted) See Electrical Data (pages 79 - 89) for availability and coordination with individual system short circuit protection.
- **BUY AMERICAN ACT COMPLIANCE** - In keeping with the “Buy America Act”, products will be comprised of 50% U.S. content and manufactured (final assembly) in the U.S.A.
- **CONTAINERIZATION SHIPPING KIT** - Additional factory fitted components for added unit strength. For container shipping (Factory Installed).
- **CONDENSER COIL PROTECTION** – Standard condenser coil construction materials include aluminum fins, copper tubes, and galvanized tube supports for generally good corrosion resistance. However, these materials are not adequate for all environments. The system designer can take steps to inhibit coil corrosion in harsh applications and enhance equipment life by choosing from these options based on project design parameters and related environmental factors. For additional application recommendations refer to Form 150.12-ES1. (Factory Mounted)
 - ◆ **PRE-COATED FIN CONDENSER COILS** – The air-cooled condenser coils are constructed of black ep.

Accessories and Options (Continued)

epoxy-coated aluminum fins. This can provide corrosion resistance comparable to copper-fin coils in typical seashore locations. Either these or the post-coated coils (below), are recommended for units being installed at the seashore or where salt spray may hit the unit

- ◆ **POST-COATED EPOXY DIPPED CONDENSER COILS** – The unit is built with dipped-cured epoxy condenser coils. This is another choice for seashore and other corrosive applications (with the exception of strong alkalis, oxidizers and wet bromine, chlorine and fluorine in concentrations greater than 100 ppm).
- ◆ **COPPER FIN CONDENSER COILS** – The unit constructed with condenser coils which have copper fins. (This is not recommended for units in areas where they may be exposed to acid rain.)
- **SERVICE ISOLATION VALVE:** Service suction isolation valve added to unit per system (Factory Mounted)
- **DX COOLER OPTIONS**
 - ◆ **300 PSIG (21 bar) Waterside Design Working Pressure** – The DX Cooler Waterside is designed and constructed for 300 PSIG (21 bar) working pressure. (Factory Mounted)
 - ◆ **1-½" Insulation** – Double thickness insulation provided for enhanced efficiency.
 - ◆ **Flange Accessory** – Consists of raised face flanges to convert grooved water nozzles to flanged cooler connections. Includes companion flanges. (Field mounted).
- **REMOTE DX COOLER** – Includes: ① Main condensing unit less cooler, refrigerant, and liquid line mechanical devices; ② Separate, insulated cooler; and ③ Field Accessory Kit (per refrigerant circuit: filter-drier shell and cores, liquid line solenoid valve, sight glass with moisture indicator, and Thermostatic Expansion Valve; also entering and leaving water temperature transducers) for use in the interconnecting system piping and wiring as designed and installed by others. Field connections made at the condensing unit liquid stub (after the sub-cooler, or the economizer if the system is so equipped) and at the compressor suction stub. Condensing Unit ships with a nitrogen holding charge. System erection, leak testing, refrigerant, and charging are by others. See Engineering Supplement 201.10-ES2 for additional information. Remote cooler configuration available with R-22 only. **NOTE:** *Remote DX cooler applications are outside the scope of ARI Standard – 550/590.*
- **FLOW SWITCH ACCESSORY** – Vapor-proof SPDT, NEMA 4X switch, 150 PSIG (10.3 bar) DWP, -20°F to 250°F (-29°C to 121°C), with 1" NPT (IPS) connection for upright mounting in horizontal pipe. (This flow switch or equivalent must be furnished with each unit). (Field mounted)
- **VIBRATION ISOLATION**
 - ◆ **Neoprene Isolation** – Recommended for normal installations. Provides very good performance in most applications for the least cost. (Field mounted)
 - ◆ **1" Spring Isolators** – Level adjustable, spring and cage type isolators for mounting under the unit base rails. 1" nominal deflection may vary slightly by application. (Field mounted)
 - ◆ **2" Seismic Spring Isolators** – Restrained Spring-Flex Mountings incorporate a rugged welded steel housing with vertical and horizontal limit stops. Housings designed to withstand a minimum 1.0g accelerated force in all directions to 2". Level adjustable, deflection may vary slightly by application. (Field mounted)
- **ALTERNATIVE CHILLED FLUID APPLICATIONS**

Standard water chilling application range is 40°F to 55°F (4°C to 13°C) Leaving Chilled Water Temperature. To protect against nuisance safety trips below 40°F (4°C) and reduce the possibility of cooler damage due to freezing during chiller operation, the unit Micro-Processor will automatically unload the compressors at abnormally low suction temperature (pressure) conditions, prior to a safety shut down.

 - ◆ **Process Brine Option** – Process or other applications requiring chilled fluid below 40°F (4°C) risk water freezing in the evaporator, which is typically overcome with antifreeze. For these applications, the chiller performance rating incorporates 'brine' (typically ethylene or propylene glycol solution), and the system design Leaving Chilled Fluid Temperature must be provided on the order form to ensure proper factory configuration. Liquid injection included with this option.
 - ◆ **Thermal Storage Option** – Thermal Storage requires special capabilities from a chiller, including the ability to 'charge' an ice storage tank, then possibly automatically reset for operation at elevated Leaving Chilled Fluid Temperatures as required by automatic building controls. The Thermal Storage Option provides Ice Storage duty Leaving Chilled Fluid setpoints to 15°F minimum (-10°C minimum) during charge cycle, with a Reset range to normal supply fluid temperature. Liquid injection included

with this option.

- **REMOTE CONTROL PANEL AND WALL ADAPTER** – See Form 201.00-SG11 for more information. *(Only one of the following options can be offered on a unit at one time: BAS, Remote Control Panel or Multi-Unit Sequence Control). (Factory mounted).*
- **MULTI-UNIT SEQUENCING** – A separate Sequencing Control Center is provided to handle sequencing control of up to eight chillers in parallel based on mixed liquid temperature (interconnecting wiring by others). *See Form 150.00-SG2 for more information. (Only one of the following options can be offered on a unit at a time: BAS, Remote Control Panel or Multi-unit Sequence Control). (Factory mounted).*
- **UNIT ENCLOSURES** –
 - ◆ **Wire Panel Enclosure (Full Unit)** – UV stabilized black polyvinylchloride coated, heavy gauge, welded wire mesh guards mounted on the exterior of the unit. Protects condenser coil faces and prevents unauthorized access to refrigerant components (compressors, pipes, cooler, etc.), yet provides free air flow. This can cut installation cost by eliminating the need for separate, expensive fencing. (Factory mounted)
 - ◆ **Louvered Panel Enclosure (Full Unit)** – Heavy gauge louver panels, galvanized and painted just as the main unit cabinet, provide liberal free air flow area. Cover coils and around the bottom of the unit to protect condenser coils, visually screen mechanical elements, and prevent unauthorized access to refrigerant components. (Factory mounted)
 - ◆ **Louvered Panels (Condenser Coil Only)** – Louvered panels are mounted over the exterior condenser coil faces on the sides of the unit to visually screen and protect coils. (Factory mounted.)
 - ◆ **Louvered (Condensers) / Wire (Mechanicals)** – Louvered panels mounted over the exterior condenser coil faces, and heavy gauge welded wire mesh guards mounted around the bottom of the unit. Visually screens and protects coils, and prevents unauthorized access to refrigerant components. (Factory mounted.)
- **HIGH STATIC FANS** – Fans and motors suitable for High External Static conditions to 0.4 inches of water (100Pa). Since these require higher power motors and therefore slightly reduce chiller efficiency, select only if the installation conditions will impose additional air flow resistance resulting from such things as field installed: ducts, filters, sound enclosures, or similar obstructions to airflow. Contact the factory for performance or electrical implications.
- **SOUND REDUCTION OPTIONS** – One or both options may be employed by the system designer as normally generated machine noise is considered in the overall project design. See Form 201.18-ES1 for additional information.
 - ◆ **Low Speed Fans** – With this option, the basic chiller is equipped with 8-pole condenser fan motors in lieu of the standard 6-pole motors, plus special fans matched to these optional slower motors to retain appropriate airflow. The net result is reduced fan generated noise with no adverse effect on the chiller capacity or efficiency performance.
 - ◆ **Compressor Sound Blanket** - Black, high-strength, rip-resistant, two-piece acoustic compressor sound blanket, offering 1dBa overall “A” weighted unit sound power reduction when fitted with the Low Noise fan option and the Condenser Perimeter Panel Enclosure. Material is both UV and mildew protected, waterproof and fire resistant (meeting California fire marshal flame specification)(Factory Fit Option).
 - ◆ **Compressor Perimeter Panel Enclosures** – Compressor acoustically treated to attenuate noise. NOTE: May ship separately from unit (Field Mounted).

Temperatures and Flows

TEMPERATURE AND FLOWS (English Units)

MODEL NUMBER YCAS	LEAVING WATER TEMPERATURE (°F)		COOLER FLOW (GPM ³)		AIR ON CONDENSER (°F)	
	MIN. ¹	MAX. ²	MIN.	MAX.	MIN.	MAX
0130EC	40	55	138	525	0	125
0140EC	40	55	138	525	0	125
0150EC	40	55	200	600	0	125
0160EC	40	55	200	600	0	125
0170EC	40	55	200	600	0	125
0180EC	40	55	200	600	0	125
0200EC	40	55	250	750	0	125
0210EC	40	55	250	750	0	125
0230EC	40	55	250	750	0	125
0250EC	40	55	225	800	0	125
0270EC	40	55	225	800	0	125
0300EC	40	55	255	800	0	125
0330EC	40	55	255	800	0	125
0360EC	40	55	300	1060	0	125
0400EC	40	55	330	1060	0	125
0440EC	40	55	330	1060	0	125

NOTES:

1. For leaving brine temperature below 40°F (4.4°C), contact your nearest YORK office for application requirements.
2. For leaving water temperature higher than 55°F (12.8°C), contact the nearest YORK office for application guidelines.
3. The evaporator is protected against freezing to -20°F (-28.8°C) with an electric heater as standard.

TEMPERATURE AND FLOWS (SI Units)

MODEL NUMBER YCAS	LEAVING WATER TEMPERATURE (°C)		COOLER FLOW (l/s ³)		AIR ON CONDENSER (°C)	
	MIN. ¹	MAX. ²	MIN.	MAX.	MIN.	MAX
0130EC	4.4	12.8	8.7	33.1	-17.7	51.7
0140EC	4.4	12.8	8.7	33.1	-17.7	51.7
0150EC	4.4	12.8	12.6	37.9	-17.7	51.7
0160EC	4.4	12.8	12.6	37.9	-17.7	51.7
0170EC	4.4	12.8	12.6	37.9	-17.7	51.7
0180EC	4.4	12.8	12.6	37.9	-17.7	51.7
0200EC	4.4	12.8	15.8	47.3	-17.7	51.7
0210EC	4.4	12.8	15.8	47.3	-17.7	51.7
0230EC	4.4	12.8	15.8	47.3	-17.7	51.7
0250EC	4.4	12.8	14.0	50.0	-17.7	51.7
0270EC	4.4	12.8	14.0	50.0	-17.7	51.7
0300EC	4.4	12.8	16.0	50.0	-17.7	51.7
0330EC	4.4	12.8	16.0	50.0	-17.7	51.7
0360EC	4.4	12.8	19.0	67.0	-17.7	51.7
0400EC	4.4	12.8	21.0	67.0	-17.7	51.7
0440EC	4.4	12.8	21.0	67.0	-17.7	51.7

NOTES:

1. For leaving brine temperature below 40°F (4.4°C), contact your nearest YORK office for application requirements.
2. For leaving water temperature higher than 55°F (12.8°C), contact the nearest YORK office for application guidelines.
3. The evaporator is protected against freezing to -20°F (-28.8°C) with an electric heater as standard.

Water Pressure Drop

ENGLISH UNITS

YCAS 130 - 440

Cooler Water Pressure Drop English Units

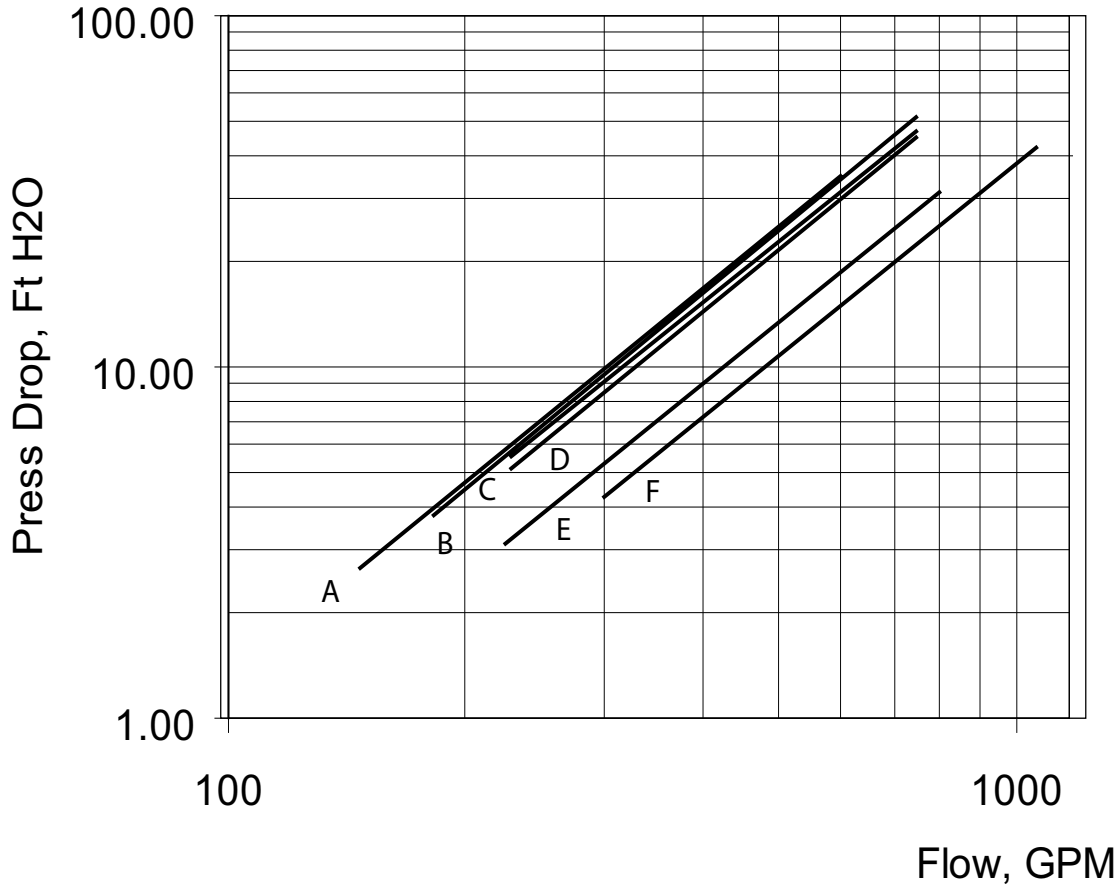

MODEL NUMBER YCAS	COOLER
0130, 0140	A
0150, 0160, 0170, 0180,	B
0200, 0210,	C
230	D
0250, 0270, 0300, 0330	E
0360, 0400, 0440	F

LD04481

SI UNITS

YCAS 130 - 440 Water Press Drop, SI Units

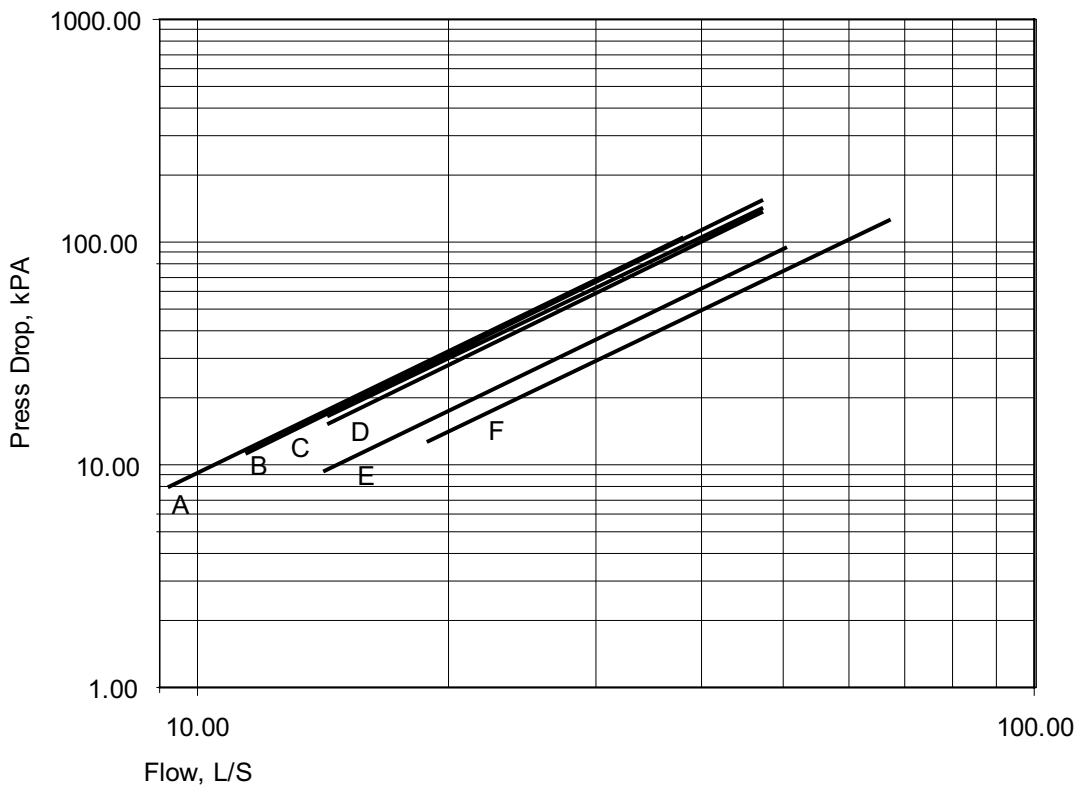

MODEL NUMBER YCAS	COOLER
0130, 0140	A
0150, 0160, 0170, 0180,	B
0200, 0210,	C
230	D
0250, 0270, 0300, 0330	E
0360, 0400, 0440	F

LD04482

Ratings – English Units - R22

MODEL: YCAS0130EC

IPLV= 13.0

AIR TEMPERATURE ON - CONDENSER (F)

LCWT (F)	75.0			80.0			85.0			90.0			95.0			100.0		
	TONS	KW	EER	TONS	KW	EER	TONS	KW	EER	TONS	KW	EER	TONS	KW	EER	TONS	KW	EER
40.0	133.2	98.3	14.2	128.7	104.8	13.0	124.4	111.7	11.8	120.4	119.1	10.8	116.5	127.1	9.9	112.8	135.7	9.0
42.0	137.8	99.8	14.5	133.2	106.2	13.3	128.8	113.3	12.1	124.6	120.8	11.1	120.6	129.0	10.1	116.7	137.8	9.2
44.0	142.5	101.1	14.8	137.7	107.7	13.5	133.2	114.8	12.4	128.8	122.5	11.3	124.7	130.8	10.3	120.8	139.7	9.4
45.0	144.8	101.7	15.0	140.0	108.4	13.7	135.4	115.6	12.5	131.0	123.4	11.4	126.8	131.8	10.4	122.8	140.7	9.5
46.0	147.2	102.4	15.1	142.3	109.1	13.8	137.6	116.4	12.6	133.2	124.2	11.5	128.9	132.7	10.5	124.9	141.7	9.6
48.0	152.0	103.6	15.5	146.9	110.5	14.1	142.1	117.9	12.9	137.5	125.9	11.8	133.2	134.5	10.7	129.0	143.7	9.8
50.0	156.9	104.7	15.8	151.7	111.7	14.4	146.7	119.3	13.2	142.0	127.5	12.0	137.5	136.3	11.0	133.3	145.7	10.0
52.0	161.8	105.9	16.1	156.5	112.9	14.7	151.4	120.7	13.5	146.6	129.0	12.3	142.0	138.0	11.2	137.6	147.5	10.2
55.0	169.4	107.4	16.7	163.7	114.6	15.2	158.6	122.6	13.9	153.6	131.2	12.7	148.7	140.4	11.5	144.2	150.3	10.5

MODEL: YCAS0140EC

IPLV= 13.5

AIR TEMPERATURE ON - CONDENSER (F)

LCWT (F)	75.0			80.0			85.0			90.0			95.0			100.0		
	TONS	KW	EER	TONS	KW	EER	TONS	KW	EER	TONS	KW	EER	TONS	KW	EER	TONS	KW	EER
40.0	136.9	100.6	14.3	133.5	108.3	13.1	130.5	116.8	11.9	127.8	126.1	10.9	125.4	136.1	10.0	123.3	147.0	9.2
42.0	141.6	101.5	14.7	138.0	109.2	13.4	134.8	117.8	12.2	132.0	127.1	11.2	129.4	137.2	10.2	127.2	148.2	9.4
44.0	146.3	102.4	15.0	142.6	110.1	13.7	139.2	118.7	12.6	136.2	128.0	11.5	133.6	138.3	10.5	131.2	149.3	9.6
45.0	148.7	102.8	15.2	144.9	110.5	13.9	141.5	119.1	12.7	138.4	128.5	11.6	135.7	138.8	10.6	133.3	149.9	9.7
46.0	151.1	103.2	15.4	147.2	111.0	14.1	143.7	119.5	12.9	140.6	129.0	11.8	137.8	139.2	10.8	135.3	150.4	9.9
48.0	156.1	103.9	15.8	152.1	111.7	14.5	148.4	120.3	13.2	145.1	129.8	12.1	142.2	140.1	11.0	139.6	151.4	10.1
50.0	161.2	104.6	16.3	156.9	112.4	14.9	153.2	121.0	13.6	149.7	130.5	12.4	146.6	140.9	11.3	144.0	152.3	10.4
52.0	166.4	105.3	16.7	162.1	113.0	15.3	158.1	121.7	13.9	154.5	131.3	12.7	151.2	141.8	11.6	148.3	153.2	10.6
55.0	174.4	106.1	17.4	169.8	114.0	15.9	165.6	122.6	14.5	161.7	132.3	13.2	158.4	143.0	12.1	155.3	154.6	11.0

MODEL: YCAS0150EC

IPLV= 12.3

AIR TEMPERATURE ON - CONDENSER (F)

LCWT (F)	75.0			80.0			85.0			90.0			95.0			100.0		
	TONS	KW	EER	TONS	KW	EER	TONS	KW	EER	TONS	KW	EER	TONS	KW	EER	TONS	KW	EER
40.0	152.2	118.2	13.8	147.8	126.4	12.6	143.7	135.4	11.5	139.9	145.2	10.5	136.4	155.7	9.6	133.1	167.0	8.8
42.0	157.3	119.7	14.1	152.8	128.0	12.9	148.6	137.1	11.8	144.6	147.0	10.7	140.9	157.7	9.8	137.5	169.2	9.0
44.0	162.6	121.2	14.4	157.9	129.7	13.1	153.5	138.8	12.0	149.4	148.8	11.0	145.6	159.7	10.0	142.0	171.3	9.2
45.0	165.2	121.9	14.5	160.4	130.5	13.3	156.0	139.7	12.1	151.8	149.7	11.1	147.9	160.6	10.1	144.4	172.3	9.3
46.0	167.9	122.7	14.7	163.0	131.2	13.4	158.5	140.6	12.3	154.3	150.6	11.2	150.3	161.6	10.3	146.7	173.3	9.4
48.0	173.4	124.0	15.0	168.3	132.7	13.7	163.6	142.2	12.5	159.2	152.4	11.5	155.2	163.4	10.5	151.4	175.3	9.6
50.0	178.9	125.4	15.4	173.7	134.1	14.0	168.8	143.7	12.8	164.3	154.1	11.7	160.1	165.3	10.7	156.2	177.4	9.8
52.0	184.5	126.7	15.7	179.2	135.5	14.3	174.1	145.2	13.1	169.4	155.8	11.9	165.1	167.2	10.9	161.1	179.4	10.0
55.0	193.1	128.6	16.2	187.5	137.7	14.8	182.2	147.5	13.5	177.3	158.3	12.3	172.7	170.0	11.2	168.5	182.6	10.3

NOTES:

1. KW = Compressor Input Power
2. EER = Chiller EER (includes power from compressors, fans, and control panels 0.8 KW)
3. LCWT = Leaving Chilled Water Temperature
4. Ratings based on 2.4 GPM cooler water per ton
5. Rated in accordance with ARI Standard 550/590-98
6. Certified in accordance with the ARI Water-Chilling Packages Using the Vapor Compression Cycle Certification Program, which is based on ARI Standard 550/590.

MODEL: YCAS0130EC

IPLV= 13.0

AIR TEMPERATURE ON - CONDENSER (°F)															
LCWT (°F)	105.0			110.0			115.0			120.0			125.0		
	TONS	KW	EER	TONS	KW	EER	TONS	KW	EER	TONS	KW	EER	TONS	KW	EER
40.0	109.3	144.9	8.2	106.0	154.6	7.5	102.8	165.0	6.9	99.8	175.9	6.3	97.1	187.5	5.8
42.0	113.1	147.1	8.4	109.7	157.0	7.7	106.5	167.5	7.0	103.5	178.7	6.4	100.6	190.5	5.9
44.0	117.1	149.2	8.6	113.6	159.3	7.8	110.3	170.1	7.2	107.0	181.3	6.6	102.6	190.7	6.0
45.0	119.1	150.3	8.7	115.5	160.5	7.9	112.1	171.4	7.2	109.0	182.9	6.6	102.9	189.8	6.0
46.0	121.1	151.4	8.8	117.5	161.7	8.0	114.1	172.7	7.3	110.9	184.2	6.7	103.3	189.0	6.1
48.0	125.1	153.6	8.9	121.4	164.1	8.2	117.9	175.2	7.5	114.7	186.9	6.8	104.4	188.2	6.2
50.0	129.2	155.7	9.1	125.5	166.4	8.3	121.9	177.7	7.6	118.6	189.6	7.0	105.2	186.9	6.3
52.0	133.5	157.7	9.3	129.6	168.6	8.5	125.9	180.1	7.8	122.5	192.3	7.1	105.9	185.7	6.4
55.0	139.9	160.8	9.6	135.9	172.0	8.7	132.1	183.9	8.0	128.6	196.4	7.3	107.0	184.0	6.5

MODEL: YCAS0140EC

IPLV= 13.5

AIR TEMPERATURE ON - CONDENSER (°F)															
LCWT (°F)	105.0			110.0			115.0			120.0			125.0		
	TONS	KW	EER	TONS	KW	EER	TONS	KW	EER	TONS	KW	EER	TONS	KW	EER
40.0	121.4	158.6	8.4	119.8	171.1	7.7	118.3	184.2	7.1	116.9	197.9	6.6	103.2	193.5	6.0
42.0	125.2	160.0	8.6	123.5	172.5	7.9	121.9	185.7	7.3	120.5	199.7	6.8	104.0	191.8	6.1
44.0	129.1	161.2	8.8	127.3	173.8	8.1	125.7	187.2	7.5	124.2	201.4	6.9	104.8	190.2	6.2
45.0	131.1	161.8	8.9	129.3	174.5	8.2	127.6	188.0	7.6	126.1	202.3	7.0	105.1	189.2	6.2
46.0	133.2	162.3	9.0	131.2	175.1	8.3	129.5	188.7	7.7	128.0	203.1	7.1	105.5	188.3	6.2
48.0	137.3	163.4	9.3	135.3	176.3	8.5	133.5	190.2	7.8	131.8	204.8	7.2	106.3	186.6	6.3
50.0	141.5	164.5	9.5	139.4	177.6	8.7	137.5	191.6	8.0	135.8	206.5	7.4	107.1	184.9	6.4
52.0	145.9	165.5	9.7	143.6	178.8	8.9	141.6	193.0	8.2	139.8	208.1	7.5	107.9	183.2	6.6
55.0	152.5	167.1	10.1	150.1	180.7	9.2	148.0	195.2	8.5	141.7	204.5	7.8	109.1	180.6	6.7

MODEL: YCAS0150EC

IPLV= 12.3

AIR TEMPERATURE ON - CONDENSER (°F)															
LCWT (°F)	105.0			110.0			115.0			120.0			125.0		
	TONS	KW	EER	TONS	KW	EER	TONS	KW	EER	TONS	KW	EER	TONS	KW	EER
40.0	130.0	179.1	8.1	127.2	191.9	7.4	124.6	205.5	6.8	122.1	219.7	6.3	100.7	203.7	5.5
42.0	134.4	181.4	8.2	131.5	194.4	7.6	128.8	208.1	6.9	125.5	221.3	6.4	101.5	202.4	5.6
44.0	138.8	183.7	8.4	135.8	196.9	7.7	133.0	210.8	7.1	127.8	221.1	6.5	102.2	201.1	5.7
45.0	141.0	184.8	8.5	138.0	198.1	7.8	135.1	212.2	7.2	129.0	221.3	6.6	102.5	200.4	5.7
46.0	143.3	185.9	8.6	140.2	199.3	7.9	137.3	213.5	7.2	130.2	221.2	6.6	102.9	199.8	5.8
48.0	147.9	188.1	8.8	144.7	201.8	8.0	141.7	216.2	7.4	132.6	221.2	6.8	103.6	198.6	5.8
50.0	152.6	190.4	8.9	149.3	204.2	8.2	146.2	219.0	7.5	135.0	221.2	6.9	104.2	197.4	5.9
52.0	157.3	192.6	9.1	153.9	206.7	8.4	150.8	221.7	7.7	137.4	221.3	7.0	104.9	196.2	6.0
55.0	164.6	196.2	9.4	161.0	210.5	8.6	157.7	226.0	7.9	138.8	218.2	7.2	105.9	194.5	6.1

NOTES:

1. KW = Compressor Input Power
2. EER = Chiller EER (includes power from compressors, fans, and control panels 0.8 KW)
3. LCWT = Leaving Chilled Water Temperature
4. Ratings based on 2.4 GPM cooler water per ton
5. Rated in accordance with ARI Standard 550/590-98
6. Certified in accordance with the ARI Water-Chilling Packages Using the Vapor Compression Cycle Certification Program, which is based on ARI Standard 550/590.

Ratings – English Units - R22

MODEL: YCAS0160EC

IPLV= 12.3

AIR TEMPERATURE ON - CONDENSER (°F)																		
LCWT (°F)	75.0			80.0			85.0			90.0			95.0			100.0		
	TONS	KW	EER	TONS	KW	EER	TONS	KW	EER	TONS	KW	EER	TONS	KW	EER	TONS	KW	EER
40.0	166.9	135.7	13.3	161.6	144.5	12.2	156.5	154.0	11.1	151.6	164.3	10.2	146.9	175.3	9.3	142.5	187.0	8.5
42.0	172.6	137.9	13.6	167.1	146.9	12.4	161.8	156.5	11.4	156.8	167.0	10.4	152.0	178.2	9.5	147.4	190.1	8.7
44.0	178.3	140.0	13.9	172.6	149.2	12.7	167.3	159.0	11.6	162.1	169.6	10.6	157.1	181.0	9.6	152.4	193.2	8.8
45.0	181.2	141.1	14.0	175.4	150.4	12.8	170.0	160.3	11.7	164.8	170.9	10.7	159.7	182.4	9.7	155.0	194.7	8.9
46.0	184.1	142.1	14.1	178.3	151.5	12.9	172.7	161.6	11.8	167.4	172.2	10.8	162.4	183.9	9.8	157.5	196.3	9.0
48.0	190.0	144.2	14.4	184.0	153.7	13.1	178.3	164.0	12.0	172.8	175.1	10.9	167.7	186.7	10.0	162.7	199.4	9.1
50.0	196.0	146.2	14.6	189.8	155.9	13.4	183.9	166.4	12.2	178.3	177.7	11.1	173.0	189.6	10.2	167.9	202.5	9.3
52.0	202.0	148.1	14.9	195.7	158.1	13.6	189.6	168.8	12.4	183.8	180.4	11.3	178.4	192.7	10.3	173.2	205.7	9.4
55.0	211.1	151.1	15.3	204.6	161.4	14.0	198.3	172.5	12.7	192.3	184.4	11.6	186.6	197.1	10.6	181.2	210.7	9.7

MODEL: YCAS0170EC

IPLV= 12.4

AIR TEMPERATURE ON - CONDENSER (°F)																		
LCWT (°F)	75.0			80.0			85.0			90.0			95.0			100.0		
	TONS	KW	EER	TONS	KW	EER	TONS	KW	EER	TONS	KW	EER	TONS	KW	EER	TONS	KW	EER
40.0	170.2	138.6	13.3	165.7	148.5	12.2	161.5	159.2	11.2	157.5	170.9	10.2	153.9	183.5	9.3	150.5	196.9	8.5
42.0	175.8	140.4	13.6	171.1	150.5	12.5	166.8	161.3	11.4	162.7	173.1	10.4	158.9	185.8	9.5	155.4	199.5	8.7
44.0	181.6	142.2	13.9	176.7	152.4	12.7	172.2	163.4	11.6	168.0	175.3	10.6	164.1	188.2	9.7	160.5	202.1	8.9
45.0	184.5	143.1	14.1	179.5	153.3	12.8	175.0	164.4	11.7	170.7	176.5	10.7	166.7	189.4	9.8	163.0	203.3	9.0
46.0	187.5	143.9	14.2	182.4	154.2	13.0	177.7	165.5	11.9	173.4	177.6	10.8	169.3	190.5	9.9	165.6	204.6	9.1
48.0	193.5	145.6	14.5	188.2	156.0	13.3	183.3	167.4	12.1	178.8	179.8	11.0	174.7	193.0	10.1	170.8	207.3	9.2
50.0	199.5	147.2	14.8	194.1	157.8	13.5	189.1	169.4	12.3	184.4	181.9	11.3	180.1	195.4	10.3	176.1	209.9	9.4
52.0	205.7	148.8	15.1	200.1	159.6	13.8	194.9	171.3	12.6	190.0	184.1	11.5	185.6	197.9	10.5	181.5	212.6	9.6
55.0	215.1	151.2	15.6	209.3	162.2	14.2	203.8	174.3	13.0	198.7	187.3	11.8	194.0	201.5	10.8	189.7	216.7	9.8

MODEL: YCAS0180EC

IPLV= 12.5

AIR TEMPERATURE ON - CONDENSER (°F)																		
LCWT (°F)	75.0			80.0			85.0			90.0			95.0			100.0		
	TONS	KW	EER	TONS	KW	EER	TONS	KW	EER	TONS	KW	EER	TONS	KW	EER	TONS	KW	EER
40.0	173.4	141.5	13.4	169.7	152.5	12.2	166.4	164.4	11.2	163.5	177.5	10.2	160.9	191.6	9.4	158.6	206.8	8.6
42.0	179.1	142.9	13.7	175.2	154.1	12.5	171.8	166.1	11.4	168.7	179.2	10.5	165.9	193.5	9.6	163.5	208.9	8.8
44.0	184.9	144.3	14.0	180.8	155.5	12.8	177.2	167.8	11.7	173.9	181.0	10.7	171.1	195.3	9.8	168.5	210.9	9.0
45.0	187.9	145.0	14.1	183.7	156.2	12.9	179.9	168.6	11.8	176.6	182.0	10.8	173.7	196.3	9.9	171.1	211.9	9.1
46.0	190.9	145.7	14.3	186.6	157.0	13.1	182.7	169.3	11.9	179.3	182.8	10.9	176.3	197.2	10.0	173.6	212.9	9.2
48.0	196.9	147.0	14.6	192.4	158.3	13.4	188.4	170.8	12.2	184.8	184.5	11.2	181.7	199.3	10.2	178.8	215.3	9.3
50.0	203.1	148.3	15.0	198.4	159.7	13.7	194.3	172.3	12.5	190.5	186.1	11.4	187.1	201.1	10.4	184.2	217.3	9.5
52.0	209.4	149.5	15.3	204.6	161.1	14.0	200.2	173.8	12.8	196.3	187.8	11.7	192.8	203.0	10.6	189.7	219.4	9.7
55.0	219.1	151.4	15.9	214.0	163.1	14.5	209.3	176.0	13.2	205.2	190.3	12.0	201.4	205.8	11.0	198.1	222.6	10.0

NOTES:

1. KW = Compressor Input Power
2. EER = Chiller EER (includes power from compressors, fans, and control panels 0.8 KW)
3. LCWT = Leaving Chilled Water Temperature
4. Ratings based on 2.4 GPM cooler water per ton
5. Rated in accordance with ARI Standard 550/590-98
6. Certified in accordance with the ARI Water-Chilling Packages Using the Vapor Compression Cycle Certification Program, which is based on ARI Standard 550/590.

MODEL: YCAS0160EC

IPLV= 12.3

AIR TEMPERATURE ON - CONDENSER (°F)															
LCWT (°F)	105.0			110.0			115.0			120.0			125.0		
	TONS	KW	EER	TONS	KW	EER	TONS	KW	EER	TONS	KW	EER	TONS	KW	EER
40.0	138.2	199.5	7.8	134.3	212.7	7.1	130.5	226.6	6.5	126.9	241.4	6.0	98.2	214.1	5.2
42.0	143.1	202.8	7.9	139.0	216.2	7.2	135.2	230.4	6.6	129.9	242.7	6.1	98.9	213.2	5.2
44.0	148.0	206.1	8.1	143.8	219.8	7.4	139.9	234.3	6.7	130.8	240.4	6.2	99.5	212.2	5.3
45.0	150.5	207.8	8.1	146.2	221.6	7.4	142.3	236.3	6.8	131.5	240.0	6.2	99.9	211.8	5.3
46.0	153.0	209.5	8.2	148.7	223.4	7.5	144.7	238.3	6.9	132.0	239.1	6.2	100.2	211.4	5.3
48.0	158.0	212.8	8.3	153.6	227.1	7.6	149.5	242.2	7.0	132.9	237.4	6.3	100.8	210.7	5.4
50.0	163.2	216.2	8.5	158.7	230.8	7.8	154.4	246.3	7.1	133.8	235.8	6.4	101.3	210.0	5.4
52.0	168.3	219.7	8.6	163.7	234.6	7.9	159.4	250.4	7.2	134.6	234.3	6.5	101.8	209.4	5.5
55.0	176.1	225.2	8.8	171.5	240.4	8.1	167.0	256.6	7.4	135.8	232.1	6.6	102.6	208.5	5.5

MODEL: YCAS0170EC

IPLV= 12.4

AIR TEMPERATURE ON - CONDENSER (°F)															
LCWT (°F)	105.0			110.0			115.0			120.0			125.0		
	TONS	KW	EER	TONS	KW	EER	TONS	KW	EER	TONS	KW	EER	TONS	KW	EER
40.0	147.4	211.2	7.8	144.5	226.5	7.2	141.7	242.4	6.6	129.0	242.8	6.0	98.6	215.8	5.1
42.0	152.2	214.0	8.0	149.2	229.5	7.3	146.3	245.8	6.7	130.9	242.4	6.1	99.3	214.7	5.2
44.0	157.1	216.8	8.2	154.0	232.6	7.5	151.1	249.2	6.9	131.9	240.2	6.2	99.9	213.6	5.3
45.0	159.6	218.2	8.2	156.4	234.2	7.6	153.5	250.9	6.9	132.4	239.5	6.3	100.2	213.1	5.3
46.0	162.1	219.7	8.3	158.9	235.7	7.6	155.6	252.1	7.0	132.9	238.5	6.3	100.6	212.5	5.3
48.0	167.2	222.5	8.5	163.9	238.9	7.8	158.5	252.3	7.1	133.8	236.6	6.4	101.2	211.5	5.4
50.0	172.4	225.5	8.6	168.9	242.0	7.9	161.6	253.0	7.3	134.7	234.7	6.5	101.8	210.4	5.4
52.0	177.6	228.4	8.8	174.1	245.4	8.0	164.4	253.4	7.4	135.6	232.9	6.6	102.4	209.4	5.5
55.0	185.6	233.0	9.0	182.0	250.3	8.2	169.1	254.3	7.6	136.7	230.1	6.7	103.3	208.0	5.6

MODEL: YCAS0180EC

IPLV= 12.5

AIR TEMPERATURE ON - CONDENSER (°F)															
LCWT (°F)	105.0			110.0			115.0			120.0			125.0		
	TONS	KW	EER	TONS	KW	EER	TONS	KW	EER	TONS	KW	EER	TONS	KW	EER
40.0	156.5	222.9	7.9	154.7	240.2	7.3	152.9	258.1	6.7	131.0	244.2	6.1	99.0	217.4	5.1
42.0	161.3	225.2	8.1	159.3	242.8	7.4	157.5	261.1	6.9	132.0	242.1	6.2	99.6	216.2	5.2
44.0	166.2	227.5	8.2	164.1	245.4	7.6	162.3	264.0	7.0	132.9	240.0	6.3	100.3	214.9	5.2
45.0	168.7	228.7	8.3	166.6	246.7	7.7	164.7	265.5	7.1	133.3	238.9	6.3	100.6	214.3	5.3
46.0	171.2	229.8	8.4	169.1	248.0	7.7	166.3	265.5	7.1	133.8	237.9	6.4	100.9	213.6	5.3
48.0	176.4	232.1	8.6	174.1	250.6	7.9	167.2	262.1	7.3	134.7	235.7	6.5	101.6	212.3	5.4
50.0	181.6	234.8	8.7	179.2	253.2	8.0	168.6	259.5	7.4	135.7	233.6	6.6	102.3	210.9	5.4
52.0	186.9	237.1	8.9	184.5	256.1	8.2	169.4	256.2	7.5	136.5	231.5	6.7	102.9	209.5	5.5
55.0	195.2	240.8	9.2	192.6	260.2	8.4	171.2	251.8	7.7	137.6	228.1	6.8	103.9	207.4	5.6

NOTES:

1. kW = Compressor Input Power
2. EER = Chiller EER (includes power from compressors, fans, and control panels 0.8 KW)
3. LCWT = Leaving Chilled Water Temperature
4. Ratings based on 2.4 GPM cooler water per ton
5. Rated in accordance with ARI Standard 550/590-98
6. Certified in accordance with the ARI Water-Chilling Packages Using the Vapor Compression Cycle Certification Program, which is based on ARI Standard 550/590.

Ratings – English Units - R22

MODEL: YCAS0200EC

IPLV= 12.1

AIR TEMPERATURE ON - CONDENSER (°F)

LCWT (°F)	75.0			80.0			85.0			90.0			95.0			100.0		
	TONS	KW	EER	TONS	KW	EER	TONS	KW	EER	TONS	KW	EER	TONS	KW	EER	TONS	KW	EER
40.0	199.6	159.6	13.5	193.2	170.0	12.3	187.1	181.1	11.3	181.2	193.1	10.3	175.6	205.9	9.4	170.2	219.5	8.6
42.0	206.3	162.1	13.7	199.8	172.7	12.6	193.5	184.0	11.5	187.5	196.2	10.5	181.7	209.2	9.6	176.2	223.1	8.8
44.0	213.2	164.6	14.0	206.5	175.3	12.8	200.0	186.8	11.7	193.8	199.2	10.7	187.9	212.5	9.8	182.3	226.7	8.9
45.0	216.7	165.8	14.1	209.8	176.6	12.9	203.3	188.2	11.8	197.0	200.7	10.8	191.0	214.1	9.9	185.3	228.4	9.0
46.0	220.1	167.0	14.3	213.2	177.9	13.1	206.6	189.6	11.9	200.2	202.2	10.9	194.2	215.8	10.0	188.4	230.2	9.1
48.0	227.2	169.3	14.6	220.1	180.4	13.3	213.3	192.4	12.2	206.7	205.2	11.1	200.5	219.0	10.1	194.6	233.8	9.3
50.0	234.3	171.6	14.8	227.0	182.9	13.6	219.9	195.1	12.4	213.2	208.2	11.3	206.9	222.3	10.3	200.8	237.3	9.4
52.0	241.5	173.8	15.1	234.0	185.4	13.8	226.8	197.8	12.6	220.0	211.2	11.5	213.4	225.6	10.5	207.2	241.0	9.6
55.0	252.5	177.1	15.5	244.7	189.1	14.2	237.2	201.9	12.9	230.1	215.7	11.8	222.9	230.4	10.8	216.8	246.4	9.8

MODEL: YCAS0210EC

IPLV= 12.2

AIR TEMPERATURE ON - CONDENSER (°F)

LCWT (°F)	75.0			80.0			85.0			90.0			95.0			100.0		
	TONS	KW	EER	TONS	KW	EER	TONS	KW	EER	TONS	KW	EER	TONS	KW	EER	TONS	KW	EER
40.0	203.2	162.6	13.5	197.8	174.1	12.4	192.7	186.7	11.3	188.0	200.3	10.3	183.6	214.8	9.5	179.5	230.5	8.7
42.0	210.0	164.7	13.8	204.4	176.3	12.6	199.1	189.0	11.5	194.2	202.8	10.6	189.6	217.5	9.7	185.4	233.4	8.8
44.0	216.9	166.7	14.1	211.1	178.5	12.9	205.6	191.3	11.8	200.5	205.2	10.8	195.8	220.2	9.9	191.4	236.3	9.0
45.0	220.4	167.7	14.2	214.5	179.5	13.0	208.9	192.5	11.9	203.7	206.5	10.9	198.9	221.6	10.0	194.4	237.8	9.1
46.0	224.0	168.7	14.4	217.9	180.6	13.2	212.2	193.6	12.0	207.0	207.7	11.0	202.1	222.9	10.1	197.5	239.2	9.2
48.0	231.1	170.6	14.7	224.8	182.6	13.4	219.0	195.8	12.3	213.5	210.1	11.2	208.4	225.5	10.3	203.8	242.1	9.4
50.0	238.3	172.4	15.0	231.9	184.7	13.7	225.7	198.0	12.5	220.2	212.5	11.5	214.9	228.2	10.5	210.1	245.0	9.6
52.0	245.7	174.3	15.3	239.0	186.7	14.0	232.8	200.2	12.8	227.0	214.9	11.7	221.6	230.8	10.7	216.5	248.0	9.8
55.0	257.0	177.0	15.8	250.0	189.6	14.4	243.5	203.5	13.2	237.4	218.5	12.0	231.6	234.8	11.0	226.4	252.4	10.0

MODEL: YCAS0230EC

IPLV= 13.9

AIR TEMPERATURE ON - CONDENSER (°F)

LCWT (°F)	75.0			80.0			85.0			90.0			95.0			100.0		
	TONS	KW	EER	TONS	KW	EER	TONS	KW	EER	TONS	KW	EER	TONS	KW	EER	TONS	KW	EER
40.0	213.1	165.5	13.9	208.4	178.3	12.7	204.3	192.2	11.7	200.6	207.4	10.7	197.3	223.8	9.8	194.4	241.3	9.0
42.0	220.1	167.2	14.3	215.2	180.0	13.0	210.8	194.1	11.9	206.9	209.3	10.9	203.5	225.9	10.0	200.4	243.6	9.2
44.0	227.2	168.8	14.6	222.1	181.7	13.3	217.5	195.8	12.2	213.4	211.2	11.2	209.8	227.9	10.2	206.6	245.9	9.4
45.0	230.9	169.6	14.8	225.6	182.5	13.5	220.7	196.6	12.3	216.8	212.2	11.3	213.0	229.0	10.4	209.7	247.1	9.5
46.0	234.5	170.4	14.9	229.2	183.3	13.7	224.4	197.5	12.5	220.1	213.1	11.4	216.3	230.0	10.5	212.9	248.2	9.6
48.0	242.0	171.8	15.3	236.4	184.9	14.0	231.4	199.2	12.8	226.9	214.9	11.7	222.9	232.0	10.7	219.3	250.5	9.8
50.0	249.6	173.3	15.7	243.8	186.4	14.3	238.6	200.9	13.1	233.9	216.7	12.0	229.7	234.0	10.9	226.0	252.7	10.0
52.0	257.4	174.7	16.0	251.4	187.9	14.6	245.9	202.5	13.4	241.0	218.6	12.2	236.6	236.0	11.2	232.7	255.0	10.2
55.0	269.3	176.8	16.6	263.0	190.2	15.2	257.2	205.0	13.8	252.0	221.3	12.6	247.3	239.1	11.5	243.1	258.4	10.6

NOTES:

1. kW = Compressor Input Power
2. EER = Chiller EER (includes power from compressors, fans, and control panels 0.8 kW)
3. LCWT = Leaving Chilled Water Temperature
4. Ratings based on 2.4 GPM cooler water per ton
5. Rated in accordance with ARI Standard 550/590-98
6. Certified in accordance with the ARI Water-Chilling Packages Using the Vapor Compression Cycle Certification Program, which is based on ARI Standard 550/590.

MODEL: YCAS0200EC

IPLV= 12.1

AIR TEMPERATURE ON - CONDENSER (°F)

LCWT (°F)	105.0			110.0			115.0			120.0			125.0		
	TONS	KW	EER	TONS	KW	EER	TONS	KW	EER	TONS	KW	EER	TONS	KW	EER
40.0	165.3	234.1	7.9	160.5	249.5	7.2	156.0	265.5	6.6	151.7	282.8	6.1	129.6	270.2	5.4
42.0	171.0	237.9	8.0	166.1	253.6	7.3	161.5	270.2	6.7	157.2	287.5	6.2	130.3	268.4	5.5
44.0	176.9	241.7	8.2	171.9	257.8	7.5	167.1	274.7	6.9	162.7	292.5	6.3	131.2	266.9	5.5
45.0	179.9	243.7	8.3	174.8	259.8	7.5	170.0	276.9	6.9	165.5	295.0	6.3	131.7	266.1	5.6
46.0	182.9	245.6	8.3	177.7	261.9	7.6	172.9	279.2	7.0	168.3	297.4	6.4	132.1	265.4	5.6
48.0	188.9	249.4	8.5	183.6	266.1	7.8	178.7	283.7	7.1	172.0	298.9	6.5	132.9	264.1	5.7
50.0	195.1	253.4	8.6	189.7	270.4	7.9	184.6	288.3	7.2	172.8	295.9	6.6	133.7	262.9	5.7
52.0	201.3	257.3	8.8	195.7	274.7	8.0	190.5	293.0	7.4	174.2	294.2	6.7	134.5	261.8	5.8
55.0	210.7	263.3	9.0	205.0	281.2	8.2	199.5	300.0	7.5	175.6	290.8	6.8	135.5	260.2	5.8

MODEL: YCAS0210EC

IPLV= 12.2

AIR TEMPERATURE ON - CONDENSER (°F)

LCWT (°F)	105.0			110.0			115.0			120.0			125.0		
	TONS	KW	EER	TONS	KW	EER	TONS	KW	EER	TONS	KW	EER	TONS	KW	EER
40.0	175.7	247.1	8.0	172.2	264.7	7.3	168.6	282.9	6.7	158.7	291.5	6.2	130.3	271.1	5.4
42.0	181.5	250.3	8.1	177.8	268.2	7.5	173.1	285.2	6.9	162.9	293.8	6.3	131.1	269.3	5.5
44.0	187.3	253.5	8.3	183.6	271.8	7.6	177.7	287.4	7.0	167.2	296.3	6.4	132.0	267.6	5.5
45.0	190.3	255.1	8.4	186.5	273.5	7.7	180.0	288.5	7.0	169.2	297.3	6.4	132.4	266.7	5.6
46.0	193.3	256.7	8.4	189.4	275.3	7.8	182.4	289.7	7.1	170.9	297.7	6.5	132.8	265.9	5.6
48.0	199.4	259.9	8.6	195.4	278.8	7.9	187.2	291.9	7.2	173.1	296.8	6.6	133.6	264.2	5.7
50.0	205.6	263.1	8.8	201.5	282.4	8.0	191.9	294.2	7.4	174.1	293.8	6.7	134.5	262.6	5.7
52.0	211.8	266.3	8.9	207.6	286.0	8.2	196.8	296.6	7.5	175.4	291.5	6.8	135.3	261.1	5.8
55.0	221.6	271.3	9.2	216.5	290.7	8.4	204.2	300.0	7.7	177.0	287.6	6.9	136.0	258.5	5.9

MODEL: YCAS0230EC

IPLV= 13.9

AIR TEMPERATURE ON - CONDENSER (°F)

LCWT (°F)	105.0			110.0			115.0			120.0			125.0		
	TONS	KW	EER	TONS	KW	EER	TONS	KW	EER	TONS	KW	EER	TONS	KW	EER
40.0	191.8	260.0	8.3	189.5	279.9	7.6	186.5	300.0	7.0	170.6	300.0	6.4	134.9	272.0	5.6
42.0	197.7	262.6	8.5	195.2	282.8	7.8	190.1	300.0	7.2	173.6	300.0	6.6	135.8	270.1	5.7
44.0	203.7	265.2	8.6	201.1	285.7	7.9	193.8	300.0	7.3	176.8	300.0	6.7	136.6	268.2	5.7
45.0	206.8	266.5	8.7	204.1	287.2	8.0	195.7	300.0	7.4	178.1	299.5	6.7	137.1	267.3	5.8
46.0	209.9	267.8	8.8	207.2	288.6	8.1	197.6	300.0	7.5	178.7	298.0	6.8	137.5	266.3	5.8
48.0	216.2	270.3	9.0	213.3	291.5	8.3	201.5	300.0	7.6	179.5	294.7	6.9	138.4	264.4	5.9
50.0	222.6	272.8	9.2	219.7	294.4	8.4	205.1	300.0	7.7	180.7	291.8	7.0	139.2	262.4	6.0
52.0	228.9	275.3	9.4	226.1	297.3	8.6	209.1	300.0	7.9	181.9	288.8	7.1	140.1	260.4	6.0
55.0	239.4	279.3	9.7	234.8	300.0	8.9	215.1	300.0	8.1	183.7	284.4	7.3	140.6	256.9	6.1

NOTES:

1. kW = Compressor Input Power
2. EER = Chiller EER (includes power from compressors, fans, and control panels 0.8 KW)
3. LCWT = Leaving Chilled Water Temperature
4. Ratings based on 2.4 GPM cooler water per ton
5. Rated in accordance with ARI Standard 550/590-98
6. Certified in accordance with the ARI Water-Chilling Packages Using the Vapor Compression Cycle Certification Program, which is based on ARI Standard 550/590.

Ratings – English Units - R-22

MODEL: YCAS0250EC

IPLV= 14.2

AIR TEMPERATURE ON - CONDENSER (°F)

LCWT (°F)	75.0			80.0			85.0			90.0			95.0			100.0		
	TONS	KW	EER	TONS	KW	EER	TONS	KW	EER	TONS	KW	EER	TONS	KW	EER	TONS	KW	EER
40.0	259.1	203.2	13.8	250.6	216.2	12.6	242.4	230.4	11.5	234.5	245.6	10.5	227.0	261.9	9.6	219.9	279.3	8.8
42.0	268.1	206.6	14.1	259.3	219.7	12.9	250.8	234.2	11.8	242.7	249.7	10.7	235.0	266.3	9.8	227.7	284.0	8.9
44.0	277.0	209.8	14.4	267.9	223.5	13.1	259.3	237.9	12.0	251.0	253.7	10.9	243.1	270.6	10.0	235.6	288.6	9.1
45.0	281.7	211.4	14.5	272.3	225.2	13.2	263.6	239.8	12.1	255.2	255.7	11.0	247.2	272.8	10.1	239.6	291.0	9.2
46.0	286.2	212.9	14.6	276.8	226.9	13.4	267.8	241.9	12.2	259.5	257.7	11.1	251.3	274.9	10.2	243.7	293.3	9.3
48.0	295.4	216.0	14.9	285.8	230.3	13.6	276.6	245.6	12.4	267.9	261.9	11.3	259.7	279.3	10.4	251.8	298.0	9.5
50.0	304.8	219.1	15.2	294.9	233.6	13.9	285.5	249.2	12.6	276.5	266.0	11.5	268.1	283.6	10.5	260.0	302.8	9.6
52.0	314.3	222.1	15.5	303.6	236.7	14.1	294.5	252.9	12.9	285.2	270.0	11.7	276.5	288.3	10.7	268.4	307.6	9.8
55.0	328.7	226.5	15.9	318.1	241.9	14.5	308.1	258.4	13.2	298.5	276.1	12.0	289.5	295.0	11.0	280.9	315.2	10.0

MODEL: YCAS0270EC

IPLV= 14.2

AIR TEMPERATURE ON - CONDENSER (°F)

LCWT (°F)	75.0			80.0			85.0			90.0			95.0			100.0		
	TONS	KW	EER	TONS	KW	EER	TONS	KW	EER	TONS	KW	EER	TONS	KW	EER	TONS	KW	EER
40.0	276.1	226.1	13.4	268.3	241.9	12.2	261.0	259.2	11.2	254.1	277.8	10.2	247.7	297.8	9.3	241.7	319.1	8.5
42.0	285.3	229.4	13.6	277.3	245.4	12.5	269.8	263.0	11.4	262.6	281.9	10.4	256.0	302.2	9.5	249.8	323.9	8.7
44.0	294.7	232.6	13.9	286.3	249.0	12.7	278.6	266.7	11.6	271.3	285.9	10.6	264.4	306.6	9.7	258.0	328.7	8.8
45.0	299.5	234.2	14.0	291.0	250.8	12.8	283.1	268.6	11.7	275.7	287.9	10.7	268.7	308.7	9.8	262.2	331.1	8.9
46.0	304.3	235.8	14.2	295.7	252.5	12.9	287.6	270.6	11.8	280.1	289.9	10.8	273.0	310.9	9.9	266.4	333.5	9.0
48.0	314.0	238.9	14.5	305.1	255.9	13.2	296.7	274.3	12.0	288.9	294.1	11.0	281.7	315.3	10.0	274.9	338.3	9.2
50.0	323.8	241.9	14.7	314.7	259.2	13.4	306.1	277.9	12.3	298.0	298.2	11.2	290.6	319.8	10.2	283.5	343.1	9.3
52.0	333.8	245.0	15.0	324.4	262.5	13.7	315.5	281.6	12.5	307.2	302.2	11.4	299.5	324.4	10.4	292.3	348.1	9.5
55.0	349.0	249.5	15.5	339.2	267.5	14.1	329.9	287.1	12.8	321.2	308.4	11.7	313.1	331.2	10.6	305.7	355.9	9.7

MODEL: YCAS0300EC

IPLV= 14.2

AIR TEMPERATURE ON - CONDENSER (°F)

LCWT (°F)	75.0			80.0			85.0			90.0			95.0			100.0		
	TONS	KW	EER	TONS	KW	EER	TONS	KW	EER	TONS	KW	EER	TONS	KW	EER	TONS	KW	EER
40.0	309.2	246.0	13.7	299.0	261.8	12.5	289.2	278.9	11.4	279.9	297.2	10.4	271.0	316.6	9.5	262.6	337.5	8.7
42.0	319.5	249.9	13.9	309.3	266.2	12.7	299.2	283.6	11.6	289.6	302.2	10.6	280.5	322.0	9.7	271.9	343.3	8.9
44.0	330.2	254.0	14.2	319.7	270.5	13.0	309.4	288.2	11.8	299.5	307.2	10.8	290.2	327.6	9.9	281.3	349.3	9.0
45.0	335.7	256.0	14.3	324.8	272.6	13.1	314.5	290.5	12.0	304.5	309.7	10.9	295.0	330.3	10.0	286.0	352.2	9.1
46.0	340.8	257.8	14.5	330.2	274.7	13.2	319.7	292.9	12.1	309.5	312.2	11.0	299.9	333.0	10.0	290.8	355.1	9.2
48.0	352.4	261.9	14.7	340.5	278.8	13.4	330.0	297.4	12.3	319.8	317.3	11.2	309.8	338.4	10.2	300.4	361.0	9.3
50.0	363.6	265.8	15.0	351.8	283.2	13.7	340.6	302.0	12.5	330.0	322.3	11.4	319.8	343.9	10.4	310.2	367.0	9.5
52.0	374.8	269.6	15.3	362.8	287.4	13.9	351.3	306.6	12.7	340.3	327.3	11.6	329.9	349.4	10.6	320.1	373.0	9.6
55.0	391.9	275.2	15.7	379.4	293.6	14.3	367.0	313.4	13.0	355.8	334.7	11.9	345.3	357.8	10.8	335.2	382.2	9.9

NOTES:

1. kW = Compressor Input Power
2. EER = Chiller EER (includes power from compressors, fans, and control panel's 0.8 KW)
3. LCWT = Leaving Chilled Water Temperature
4. Ratings based on 2.4 GPM cooler water per ton
5. Rated in accordance with ARI Standard 550/590.

MODEL: YCAS0250EC

IPLV= 14.2

AIR TEMPERATURE ON - CONDENSER (°F)															
LCWT (°F)	105.0			110.0			115.0			120.0			125.0		
	TONS	KW	EER	TONS	KW	EER	TONS	KW	EER	TONS	KW	EER	TONS	KW	EER
40.0	213.0	297.6	8.0	206.9	317.3	7.3	200.9	338.0	6.7	195.3	359.9	6.1	157.0	306.3	5.7
42.0	220.8	302.8	8.2	214.3	322.7	7.5	208.2	343.8	6.8	201.9	365.0	6.3	158.6	302.8	5.9
44.0	228.6	307.8	8.3	221.7	328.0	7.6	215.6	349.6	7.0	204.3	359.3	6.4	160.2	299.4	6.0
45.0	232.5	310.4	8.4	225.7	330.9	7.7	219.4	352.6	7.0	205.4	356.5	6.5	161.0	297.8	6.0
46.0	236.4	312.9	8.5	229.6	333.7	7.8	223.2	355.6	7.1	206.6	355.0	6.6	161.8	296.3	6.1
48.0	244.3	318.0	8.6	237.4	339.2	7.9	230.8	361.6	7.2	208.8	350.0	6.7	163.2	293.2	6.2
50.0	252.4	323.2	8.8	245.2	344.8	8.0	238.6	367.7	7.4	210.8	345.3	6.9	164.7	290.3	6.3
52.0	260.6	328.4	8.9	253.2	350.5	8.2	246.4	373.9	7.5	212.8	340.8	7.0	166.1	287.6	6.4
55.0	272.9	336.6	9.1	265.4	359.2	8.4	258.3	383.4	7.7	215.5	334.3	7.3	168.0	283.8	6.6

MODEL: YCAS0270EC

IPLV= 14.2

AIR TEMPERATURE ON - CONDENSER (°F)															
LCWT (°F)	105.0			110.0			115.0			120.0			125.0		
	TONS	KW	EER	TONS	KW	EER	TONS	KW	EER	TONS	KW	EER	TONS	KW	EER
40.0	236.0	341.5	7.8	229.2	361.9	7.2	217.5	371.0	6.6	198.4	365.6	6.1	157.0	311.9	5.7
42.0	243.9	346.9	7.9	236.1	365.5	7.3	223.1	372.8	6.8	203.4	367.2	6.3	158.5	308.6	5.8
44.0	252.0	352.2	8.1	243.1	369.1	7.5	228.8	374.7	6.9	205.4	361.8	6.4	160.0	305.5	5.9
45.0	256.1	354.8	8.2	246.6	370.9	7.5	231.7	375.6	7.0	206.4	359.1	6.5	160.7	304.0	5.9
46.0	260.2	357.4	8.2	250.2	372.8	7.6	234.6	376.6	7.1	207.5	357.4	6.6	161.4	302.4	6.0
48.0	268.3	362.4	8.4	257.2	376.5	7.8	240.5	378.6	7.2	209.5	352.7	6.7	162.8	299.5	6.1
50.0	276.0	365.8	8.5	264.5	380.2	7.9	246.4	380.6	7.4	211.5	348.1	6.9	164.2	296.7	6.2
52.0	283.7	369.3	8.7	271.9	384.1	8.0	252.3	382.7	7.5	213.3	343.6	7.0	165.5	293.9	6.3
55.0	295.3	374.9	8.9	281.9	387.1	8.3	261.1	385.8	7.7	216.0	337.2	7.2	167.4	290.0	6.4

MODEL: YCAS0300EC

IPLV= 14.2

AIR TEMPERATURE ON - CONDENSER (°F)															
LCWT (°F)	105.0			110.0			115.0			120.0			125.0		
	TONS	KW	EER	TONS	KW	EER	TONS	KW	EER	TONS	KW	EER	TONS	KW	EER
40.0	254.6	359.7	7.9	247.1	383.2	7.3	240.1	407.9	6.7	224.1	410.8	6.2	188.9	371.3	5.7
42.0	263.7	366.0	8.1	255.9	389.9	7.4	248.7	415.3	6.8	230.6	413.8	6.3	190.8	367.0	5.8
44.0	272.9	372.2	8.2	264.9	396.7	7.5	256.8	420.8	6.9	237.1	417.3	6.4	192.7	362.8	6.0
45.0	277.5	375.4	8.3	269.5	400.1	7.6	260.2	421.8	7.0	240.4	419.0	6.5	193.7	360.8	6.0
46.0	282.2	378.5	8.4	274.1	403.5	7.7	263.7	422.9	7.1	243.7	420.7	6.6	194.5	358.8	6.1
48.0	291.6	385.1	8.5	283.3	410.5	7.8	270.7	425.7	7.2	249.1	421.3	6.7	196.3	355.1	6.2
50.0	301.1	391.6	8.7	292.6	417.7	7.9	277.7	428.3	7.3	251.2	414.7	6.9	197.9	351.5	6.3
52.0	310.8	398.1	8.8	302.0	424.6	8.1	284.8	431.1	7.5	253.6	410.0	7.0	199.6	348.1	6.4
55.0	325.6	408.2	9.0	314.7	431.3	8.3	295.2	435.3	7.7	256.6	401.9	7.2	201.8	343.3	6.6

NOTES:

1. kW = Compressor Input Power
2. EER = Chiller EER (includes power from compressors, fans, and control panel's 0.8 KW)
3. LCWT = Leaving Chilled Water Temperature
4. Ratings based on 2.4 GPM cooler water per ton
5. Rated in accordance with ARI Standard 550/590.

Ratings – English Units - R-22

MODEL: YCAS0330EC

IPLV= 14.6

AIR TEMPERATURE ON - CONDENSER (°F)

LCWT (°F)	75.0			80.0			85.0			90.0			95.0			100.0		
	TONS	KW	EER	TONS	KW	EER	TONS	KW	EER	TONS	KW	EER	TONS	KW	EER	TONS	KW	EER
40.0	320.4	256.8	13.6	313.3	276.7	12.5	307.1	298.5	11.4	301.5	322.2	10.4	296.6	347.6	9.5	292.2	375.0	8.8
42.0	331.0	259.6	13.9	323.2	279.6	12.7	316.7	301.5	11.6	311.1	325.5	10.6	305.9	351.3	9.8	301.3	379.0	8.9
44.0	341.8	262.3	14.3	334.1	282.5	13.0	326.9	304.6	11.9	321.0	328.8	10.9	315.5	354.9	10.0	310.6	383.0	9.1
45.0	347.3	263.6	14.4	339.4	283.9	13.2	331.9	306.0	12.0	325.8	330.3	11.0	320.4	356.7	10.1	315.4	385.0	9.2
46.0	352.9	264.9	14.6	344.8	285.3	13.3	337.5	307.6	12.2	330.5	331.8	11.1	325.3	358.5	10.2	320.2	387.0	9.3
48.0	364.2	267.5	14.9	355.7	288.0	13.6	348.2	310.6	12.4	341.4	335.2	11.4	335.0	361.9	10.4	329.9	391.0	9.5
50.0	375.7	270.0	15.3	366.9	290.7	13.9	359.0	313.5	12.7	351.9	338.5	11.6	345.6	365.6	10.6	339.9	395.0	9.7
52.0	387.5	272.5	15.6	378.3	293.4	14.3	370.1	316.4	13.0	362.8	341.8	11.9	356.1	369.2	10.8	350.2	399.1	9.9
55.0	405.5	276.2	16.1	395.8	297.4	14.7	387.1	320.9	13.4	379.2	346.6	12.2	372.2	374.8	11.2	365.7	405.2	10.2

MODEL: YCAS0360EC

IPLV= 16.0

AIR TEMPERATURE ON - CONDENSER (°F)

LCWT (°F)	75.0			80.0			85.0			90.0			95.0			100.0		
	TONS	KW	EER	TONS	KW	EER	TONS	KW	EER	TONS	KW	EER	TONS	KW	EER	TONS	KW	EER
40.0	374.8	307.2	13.4	362.5	327.0	12.2	350.8	348.5	11.2	339.7	371.4	10.2	329.0	395.9	9.3	318.8	422.1	8.5
42.0	387.4	312.4	13.6	374.9	332.8	12.4	362.9	354.6	11.4	351.3	378.1	10.4	340.5	402.9	9.5	330.0	429.6	8.6
44.0	400.5	317.8	13.9	387.5	338.5	12.7	375.1	360.7	11.6	363.3	384.6	10.5	352.0	410.2	9.6	341.4	437.1	8.8
45.0	407.0	320.3	14.0	393.8	341.3	12.8	381.2	363.8	11.6	369.2	387.8	10.6	357.9	413.7	9.7	347.0	441.2	8.9
46.0	413.5	322.9	14.1	400.2	344.1	12.9	387.4	366.8	11.7	375.3	391.1	10.7	363.7	417.2	9.8	352.8	445.0	8.9
48.0	426.8	328.0	14.4	413.0	349.6	13.1	399.9	372.8	11.9	387.4	397.8	10.9	375.7	424.3	9.9	364.4	452.7	9.1
50.0	440.1	333.0	14.6	426.0	355.1	13.3	412.6	378.9	12.1	399.8	404.4	11.1	387.7	431.4	10.1	376.3	460.5	9.2
52.0	453.7	338.0	14.8	439.2	360.6	13.5	425.4	384.9	12.3	412.3	411.0	11.3	399.8	438.8	10.3	388.0	468.2	9.4
55.0	474.2	345.5	15.2	459.2	368.8	13.9	444.9	394.0	12.6	431.3	421.0	11.5	418.4	449.8	10.5	406.3	480.7	9.6

MODEL: YCAS0400EC

IPLV= 15.8

AIR TEMPERATURE ON - CONDENSER (°F)

LCWT (°F)	75.0			80.0			85.0			90.0			95.0			100.0		
	TONS	KW	EER	TONS	KW	EER	TONS	KW	EER	TONS	KW	EER	TONS	KW	EER	TONS	KW	EER
40.0	414.1	332.0	13.6	400.5	353.4	12.5	387.0	376.3	11.4	374.9	401.2	10.4	363.3	427.5	9.5	352.0	455.7	8.7
42.0	428.3	337.7	13.9	414.2	359.5	12.7	400.8	383.0	11.6	388.0	408.2	10.6	375.5	435.0	9.6	364.4	463.6	8.8
44.0	442.6	343.3	14.1	428.2	365.5	12.9	414.3	389.5	11.8	401.2	415.2	10.8	388.7	442.6	9.8	376.9	472.0	9.0
45.0	449.8	346.0	14.3	435.1	368.5	13.0	421.2	392.7	11.9	407.8	418.6	10.9	395.2	446.4	9.9	383.0	475.9	9.0
46.0	457.1	348.7	14.4	442.2	371.4	13.1	428.1	395.9	12.0	414.5	422.1	10.9	401.7	450.2	10.0	389.6	480.1	9.1
48.0	471.7	354.1	14.6	456.5	377.3	13.4	441.9	402.3	12.2	428.1	429.1	11.1	414.9	457.7	10.2	402.5	488.3	9.3
50.0	486.5	359.5	14.9	470.9	383.2	13.6	455.9	408.6	12.4	441.8	436.0	11.3	428.3	465.3	10.3	415.5	496.6	9.4
52.0	501.5	364.8	15.2	485.5	389.0	13.8	470.2	415.1	12.6	455.6	443.1	11.5	441.8	473.0	10.5	428.7	505.0	9.6
55.0	524.2	372.7	15.5	507.6	397.7	14.2	491.8	424.7	12.9	476.7	453.7	11.8	462.4	484.7	10.7	448.9	517.7	9.8

NOTES:

1. kW = Compressor Input Power
2. EER = Chiller EER (includes power from compressors, fans, and control panel's 0.8 KW)
3. LCWT = Leaving Chilled Water Temperature
4. Ratings based on 2.4 GPM cooler water per ton
5. Rated in accordance with ARI Standard 550/590.

MODEL: YCAS0330EC

IPLV= 14.6

AIR TEMPERATURE ON - CONDENSER (°F)															
LCWT (°F)	105.0			110.0			115.0			120.0			125.0		
	TONS	KW	EER	TONS	KW	EER	TONS	KW	EER	TONS	KW	EER	TONS	KW	EER
40.0	288.3	403.9	8.1	282.9	430.1	7.5	271.7	444.5	6.9	244.0	424.8	6.5	193.1	362.6	6.0
42.0	297.2	408.5	8.2	290.7	433.0	7.6	276.7	442.4	7.1	247.9	422.4	6.6	194.7	358.6	6.1
44.0	306.3	413.0	8.4	298.6	435.9	7.8	281.8	440.4	7.3	250.1	416.4	6.8	196.4	354.6	6.2
45.0	311.0	415.3	8.5	302.7	437.4	7.9	284.4	439.3	7.3	251.3	413.4	6.9	197.2	352.6	6.3
46.0	315.7	417.5	8.6	306.7	438.9	7.9	287.0	438.3	7.4	252.3	410.4	7.0	198.0	350.6	6.3
48.0	324.7	420.7	8.7	315.0	441.8	8.1	292.3	436.3	7.6	254.2	404.1	7.1	199.6	346.6	6.4
50.0	333.3	423.2	8.9	323.6	444.7	8.3	297.6	434.3	7.8	256.4	398.3	7.3	201.2	342.7	6.6
52.0	342.6	425.8	9.1	332.1	447.5	8.4	302.7	432.3	7.9	258.6	392.6	7.4	202.5	338.4	6.7
55.0	356.2	429.8	9.4	342.4	445.9	8.7	310.6	429.0	8.2	261.8	383.9	7.7	204.6	332.4	6.9

MODEL: YCAS0360EC

IPLV= 16.0

AIR TEMPERATURE ON - CONDENSER (°F)															
LCWT (°F)	105.0			110.0			115.0			120.0			125.0		
	TONS	KW	EER	TONS	KW	EER	TONS	KW	EER	TONS	KW	EER	TONS	KW	EER
40.0	309.2	450.1	7.7	300.1	479.5	7.1	291.5	510.7	6.5	265.9	498.9	6.0	209.6	421.2	5.6
42.0	320.1	458.1	7.9	310.8	488.1	7.2	302.1	520.0	6.6	271.3	497.5	6.2	211.7	416.9	5.7
44.0	331.3	466.2	8.0	321.7	496.9	7.3	312.4	528.3	6.7	274.1	490.3	6.3	213.6	412.8	5.8
45.0	336.9	470.3	8.1	327.2	501.3	7.4	315.7	527.7	6.8	275.6	487.0	6.4	214.6	410.9	5.9
46.0	342.5	474.4	8.2	332.8	505.8	7.5	319.1	527.2	6.9	277.0	484.4	6.5	215.5	409.0	5.9
48.0	353.8	483.0	8.3	344.1	514.9	7.6	326.1	527.6	7.0	279.6	478.3	6.6	217.3	405.4	6.0
50.0	365.4	491.4	8.4	355.2	524.3	7.7	332.8	527.5	7.2	282.1	472.4	6.8	219.1	401.9	6.1
52.0	377.1	500.0	8.6	366.7	533.7	7.8	339.6	527.7	7.3	284.6	466.8	6.9	220.7	398.7	6.2
55.0	394.8	513.4	8.7	381.0	540.5	8.0	349.6	528.1	7.5	288.0	458.7	7.1	223.1	394.2	6.3

MODEL: YCAS0400EC

IPLV= 15.8

AIR TEMPERATURE ON - CONDENSER (°F)															
LCWT (°F)	105.0			110.0			115.0			120.0			125.0		
	TONS	KW	EER	TONS	KW	EER	TONS	KW	EER	TONS	KW	EER	TONS	KW	EER
40.0	341.2	485.6	7.9	331.4	517.3	7.2	321.9	550.8	6.6	293.5	538.0	6.2	243.5	480.3	5.7
42.0	353.1	494.1	8.0	343.1	526.6	7.4	333.4	560.9	6.7	300.8	539.4	6.3	246.0	475.1	5.8
44.0	365.3	502.6	8.2	355.2	536.0	7.5	343.1	565.5	6.9	307.9	541.2	6.4	248.4	469.9	5.9
45.0	371.9	507.3	8.3	360.8	540.3	7.6	346.9	565.2	7.0	311.6	542.2	6.5	249.6	467.4	6.0
46.0	378.1	512.0	8.3	366.7	544.9	7.6	350.9	565.1	7.0	315.2	543.1	6.6	250.7	465.0	6.0
48.0	390.6	520.8	8.5	379.6	555.3	7.8	358.8	566.3	7.2	322.2	544.5	6.7	252.9	460.5	6.2
50.0	403.5	529.8	8.6	392.2	565.3	7.9	366.6	566.8	7.3	325.1	536.8	6.9	254.9	456.1	6.3
52.0	416.4	539.0	8.7	404.2	573.6	8.0	374.4	567.6	7.5	328.0	530.4	7.0	257.0	452.0	6.4
55.0	436.1	553.0	8.9	419.8	580.2	8.2	385.9	568.9	7.7	331.8	520.4	7.2	259.8	446.2	6.5

NOTES:

1. kW = Compressor Input Power
2. EER = Chiller EER (includes power from compressors, fans, and control panel's 0.8 KW)
3. LCWT = Leaving Chilled Water Temperature
4. Ratings based on 2.4 GPM cooler water per ton
5. Rated in accordance with ARI Standard 550/590.

Ratings – English Units - R-22

MODEL: YCAS0440EC

IPLV= 15.8

AIR TEMPERATURE ON - CONDENSER (°F)

LCWT (°F)	75.0			80.0			85.0			90.0			95.0			100.0		
	TONS	KW	EER	TONS	KW	EER	TONS	KW	EER	TONS	KW	EER	TONS	KW	EER	TONS	KW	EER
40.0	426.4	347.8	13.5	417.2	375.0	12.3	409.0	404.6	11.2	401.7	436.8	10.3	395.4	471.4	9.4	389.6	508.6	8.6
42.0	440.4	351.7	13.8	430.7	379.1	12.6	422.1	409.0	11.5	414.5	441.5	10.5	407.7	476.6	9.6	401.7	514.3	8.8
44.0	454.7	355.5	14.1	444.6	383.1	12.8	435.6	413.3	11.7	427.5	446.2	10.7	420.4	481.7	9.8	414.1	520.1	9.0
45.0	462.0	357.4	14.2	451.7	385.1	13.0	442.4	415.4	11.9	434.2	448.5	10.8	426.9	484.2	9.9	420.4	522.9	9.1
46.0	469.3	359.2	14.4	458.8	387.0	13.1	449.3	417.5	12.0	440.9	450.8	10.9	433.4	486.8	10.0	427.0	525.7	9.2
48.0	484.2	362.8	14.7	473.2	390.9	13.4	463.3	421.7	12.2	454.5	455.4	11.2	446.7	491.9	10.2	439.7	531.4	9.4
50.0	499.5	366.4	15.0	488.0	394.7	13.7	477.7	425.9	12.5	468.5	460.0	11.4	460.3	497.0	10.4	453.0	537.1	9.5
52.0	515.0	369.9	15.4	503.1	398.5	14.0	492.3	430.1	12.8	482.7	464.6	11.7	474.1	502.2	10.6	466.5	542.9	9.7
55.0	538.8	375.2	15.9	526.2	404.3	14.5	514.8	436.4	13.2	504.6	471.7	12.0	495.5	510.1	11.0	487.3	551.9	10.0

NOTES:

1. kW = Compressor Input Power
2. EER = Chiller EER (includes power from compressors, fans, and control panel's 0.8 KW)
3. LCWT = Leaving Chilled Water Temperature
4. Ratings based on 2.4 GPM cooler water per ton
5. Rated in accordance with ARI Standard 550/590.

MODEL: YCAS0440EC

IPLV= 15.8

AIR TEMPERATURE ON - CONDENSER (°F)

LCWT (°F)	105.0			110.0			115.0			120.0			125.0		
	TONS	KW	EER	TONS	KW	EER	TONS	KW	EER	TONS	KW	EER	TONS	KW	EER
40.0	383.6	547.0	7.9	375.6	579.4	7.4	355.8	588.5	6.9	312.8	549.3	6.5	246.4	470.6	5.9
42.0	396.4	554.4	8.1	385.1	582.3	7.5	361.6	584.3	7.0	317.8	546.4	6.6	248.4	465.7	6.0
44.0	408.6	560.8	8.3	394.8	585.3	7.7	367.4	580.3	7.2	320.6	539.0	6.7	250.4	461.0	6.1
45.0	414.6	564.0	8.3	400.3	586.7	7.8	370.4	578.2	7.3	322.0	535.2	6.8	251.5	458.3	6.2
46.0	420.9	567.2	8.4	405.1	588.1	7.8	373.3	576.2	7.4	323.4	531.5	6.9	252.5	455.8	6.2
48.0	431.9	570.0	8.6	415.5	591.1	8.0	379.3	572.1	7.5	325.8	523.8	7.0	254.5	450.9	6.3
50.0	443.0	572.5	8.8	426.1	594.0	8.2	385.5	567.8	7.7	328.6	516.5	7.2	256.6	446.0	6.4
52.0	454.4	575.1	9.0	436.1	595.3	8.3	391.6	563.8	7.9	331.3	509.3	7.3	258.6	441.1	6.6
55.0	471.8	579.1	9.3	448.1	590.7	8.6	399.9	557.3	8.1	335.5	498.7	7.6	261.3	433.5	6.7

NOTES:

1. kW = Compressor Input Power
2. EER = Chiller EER (includes power from compressors, fans, and control panel's 0.8 KW)
3. LCWT = Leaving Chilled Water Temperature
4. Ratings based on 2.4 GPM cooler water per ton
5. Rated in accordance with ARI Standard 550/590.

Ratings – SI Units - R22

MODEL YCAS0130EC

AIR TEMPERATURE ON - CONDENSER (C)																		
LCWT (°C)	25.0			30.0			35.0			40.0			45.0			50.0		
	KW	KW	COP	KW	KW	COP	KW	KW	COP	KW	KW	COP	KW	KW	COP	KW	KW	COP
5.0	469.8	101.6	4.1	442.2	113.9	3.5	416.7	128.1	2.9	393.5	144.1	2.5	372.4	162.0	2.1	353.4	181.9	1.8
6.0	484.4	102.8	4.1	455.9	115.4	3.5	429.7	129.7	3.0	405.9	146.0	2.5	384.2	164.2	2.2	364.9	184.4	1.8
7.0	499.0	104.0	4.2	469.8	116.8	3.6	442.9	131.4	3.0	418.4	147.9	2.6	396.3	166.4	2.2	376.5	187.0	1.9
8.0	513.9	105.2	4.3	483.9	118.2	3.7	456.3	133.0	3.1	431.1	149.8	2.6	408.5	168.7	2.2	388.5	189.6	1.9
9.0	528.9	106.4	4.4	498.1	119.6	3.7	469.8	134.7	3.2	444.0	151.8	2.7	420.9	170.9	2.3	400.4	192.0	1.9
10.0	544.2	107.5	4.5	512.6	120.9	3.8	483.6	136.3	3.2	457.2	153.6	2.7	433.5	173.0	2.3	412.6	194.5	2.0
11.0	559.8	108.5	4.6	527.2	122.1	3.9	497.6	137.8	3.3	470.6	155.4	2.8	446.4	175.2	2.4	425.0	197.0	2.0
12.0	574.5	109.5	4.6	542.3	123.4	3.9	510.6	139.1	3.3	484.2	157.2	2.8	459.4	177.3	2.4	437.5	199.6	2.0
13.0	591.2	110.5	4.7	557.5	124.5	4.0	525.8	140.7	3.4	497.9	159.0	2.9	472.5	179.5	2.4	443.5	199.4	2.1

MODEL YCAS0140EC

AIR TEMPERATURE ON - CONDENSER (C)																		
LCWT (°C)	25.0			30.0			35.0			40.0			45.0			50.0		
	KW	KW	COP	KW	KW	COP	KW	KW	COP	KW	KW	COP	KW	KW	COP	KW	KW	COP
5.0	484.5	104.1	4.1	464.3	119.1	3.5	448.0	136.7	3.0	434.9	156.9	2.5	424.4	179.6	2.2	415.6	204.4	1.9
6.0	499.1	104.9	4.2	478.0	119.9	3.6	460.9	137.6	3.0	447.1	158.0	2.6	436.2	180.9	2.2	427.1	206.2	1.9
7.0	514.0	105.6	4.3	492.0	120.7	3.6	474.1	138.6	3.1	459.7	159.1	2.7	448.2	182.2	2.3	434.7	206.1	2.0
8.0	529.2	106.3	4.4	506.3	121.5	3.7	487.6	139.4	3.2	472.6	160.1	2.7	460.5	183.4	2.3	437.4	203.9	2.0
9.0	544.8	107.0	4.5	521.0	122.2	3.8	501.5	140.2	3.2	485.8	161.0	2.8	473.2	184.7	2.4	440.6	202.1	2.0
10.0	560.7	107.6	4.6	536.1	122.8	3.9	515.7	140.9	3.3	499.2	162.0	2.8	486.0	185.9	2.4	444.5	200.3	2.1
11.0	576.8	108.2	4.7	550.9	123.4	4.0	530.0	141.7	3.4	512.9	162.9	2.9	499.3	187.1	2.5	447.6	198.3	2.1
12.0	593.4	108.8	4.8	567.1	124.0	4.1	545.1	142.4	3.5	527.1	163.8	3.0	511.4	188.2	2.5	450.6	196.4	2.1
13.0	610.2	109.3	4.9	583.4	124.6	4.2	559.9	143.1	3.6	541.3	164.8	3.0	526.3	189.6	2.6	453.7	194.4	2.2

MODEL YCAS0150EC

AIR TEMPERATURE ON - CONDENSER (C)																		
LCWT (°C)	25.0			30.0			35.0			40.0			45.0			50.0		
	KW	KW	COP	KW	KW	COP	KW	KW	COP	KW	KW	COP	KW	KW	COP	KW	KW	COP
5.0	537.7	122.2	3.9	511.0	138.2	3.4	487.5	156.7	2.9	466.9	177.7	2.4	449.1	201.2	2.1	414.4	217.9	1.8
6.0	553.9	123.6	4.0	526.4	139.7	3.4	502.1	158.5	2.9	480.8	179.8	2.5	462.5	203.6	2.1	421.6	218.1	1.8
7.0	570.4	125.0	4.1	542.0	141.3	3.5	516.9	160.2	3.0	495.0	181.8	2.5	476.1	205.9	2.2	426.3	217.2	1.8
8.0	587.2	126.3	4.2	557.7	142.8	3.6	532.0	161.9	3.0	509.4	183.7	2.6	489.9	208.2	2.2	428.9	215.5	1.9
9.0	604.3	127.5	4.3	573.9	144.3	3.6	547.3	163.6	3.1	524.1	185.7	2.6	504.0	210.6	2.2	432.2	214.1	1.9
10.0	621.6	128.8	4.3	590.3	145.7	3.7	563.0	165.3	3.1	539.0	187.7	2.7	518.3	212.9	2.3	434.9	212.6	1.9
11.0	639.1	130.0	4.4	607.0	147.1	3.8	578.6	167.0	3.2	554.1	189.7	2.7	532.8	215.3	2.3	437.6	211.1	1.9
12.0	656.9	131.2	4.5	623.9	148.5	3.8	594.7	168.7	3.3	569.4	191.7	2.8	547.6	217.7	2.4	440.3	209.6	2.0
13.0	675.0	132.4	4.6	641.1	149.9	3.9	611.1	170.4	3.3	584.9	193.9	2.8	562.5	220.2	2.4	442.9	208.1	2.0

MODEL YCAS0160EC

AIR TEMPERATURE ON - CONDENSER (C)																		
LCWT (°C)	25.0			30.0			35.0			40.0			45.0			50.0		
	KW	KW	COP	KW	KW	COP	KW	KW	COP	KW	KW	COP	KW	KW	COP	KW	KW	COP
5.0	589.0	140.3	3.8	556.1	157.3	3.2	525.5	176.7	2.8	497.6	198.5	2.3	472.3	222.7	2.0	411.8	231.2	1.7
6.0	606.9	142.3	3.9	573.1	159.5	3.3	541.6	179.3	2.8	513.0	201.5	2.4	487.2	226.1	2.0	414.7	229.8	1.7
7.0	624.9	144.3	3.9	590.2	161.8	3.4	558.0	181.9	2.8	528.7	204.4	2.4	502.4	229.5	2.1	417.4	228.6	1.7
8.0	643.2	146.2	4.0	607.2	164.2	3.4	574.6	184.4	2.9	544.6	207.4	2.5	517.7	232.9	2.1	420.0	227.4	1.7
9.0	661.6	148.1	4.1	624.8	166.4	3.5	591.4	187.0	2.9	560.7	210.4	2.5	533.2	236.4	2.1	422.6	226.1	1.8
10.0	680.2	150.0	4.1	642.6	168.6	3.5	608.4	189.6	3.0	577.0	213.4	2.5	548.9	239.9	2.2	425.0	225.0	1.8
11.0	699.1	151.8	4.2	660.5	170.8	3.6	625.2	192.4	3.0	593.4	216.5	2.6	564.8	243.5	2.2	427.3	224.0	1.8
12.0	718.2	153.7	4.3	678.7	173.0	3.6	642.5	195.1	3.1	610.1	219.6	2.6	580.9	247.1	2.2	429.6	223.0	1.8
13.0	737.3	155.5	4.3	697.0	175.3	3.7	660.0	197.7	3.1	626.6	223.0	2.6	597.0	250.8	2.3	431.7	222.1	1.8

NOTES:

1. kW = Compressor Input Power
2. EER = Chiller EER (includes power from compressors, fans, and control panel's 0.8 KW)
3. LCWT = Leaving Chilled Water Temperature
4. Ratings based on 2.4 GPM cooler water per ton
5. Rated in accordance with ARI Standard 550/590.

MODEL YCAS0170EC**AIR TEMPERATURE ON - CONDENSER (C)**

LCWT (°C)	25.0			30.0			35.0			40.0			45.0			50.0		
	KW	KW	COP	KW	KW	COP	KW	KW	COP	KW	KW	COP	KW	KW	COP	KW	KW	COP
5.0	601.6	143.4	3.8	574.2	162.5	3.3	550.0	184.7	2.8	528.9	209.6	2.4	510.3	237.5	2.0	414.4	231.8	1.7
6.0	619.5	145.1	3.9	591.1	164.5	3.3	566.1	186.8	2.8	544.3	212.1	2.4	525.2	240.4	2.1	417.3	230.2	1.7
7.0	637.7	146.7	4.0	608.3	166.3	3.4	582.5	188.9	2.9	560.0	214.6	2.5	540.3	243.4	2.1	419.9	228.8	1.7
8.0	656.1	148.3	4.0	625.6	168.2	3.4	599.1	191.1	2.9	575.9	217.1	2.5	555.7	246.4	2.1	422.6	227.3	1.8
9.0	674.8	149.8	4.1	643.4	170.0	3.5	616.0	193.2	3.0	592.2	219.6	2.5	571.4	249.4	2.2	425.1	226.0	1.8
10.0	693.8	151.3	4.2	661.4	171.8	3.6	633.2	195.4	3.0	608.6	222.3	2.6	587.2	252.5	2.2	427.6	224.6	1.8
11.0	713.1	152.8	4.3	679.7	173.6	3.6	650.5	197.6	3.1	625.3	224.9	2.6	603.4	255.6	2.2	430.1	223.3	1.8
12.0	732.6	154.3	4.3	698.3	175.4	3.7	668.2	199.8	3.1	642.3	227.5	2.7	612.5	255.5	2.3	432.4	221.9	1.8
13.0	752.4	155.8	4.4	717.2	177.2	3.7	686.2	201.9	3.2	659.4	230.2	2.7	622.4	255.8	2.3	434.3	220.6	1.9

MODEL YCAS0180EC**AIR TEMPERATURE ON - CONDENSER (C)**

LCWT (°C)	25.0			30.0			35.0			40.0			45.0			50.0		
	KW	KW	COP	KW	KW	COP	KW	KW	COP	KW	KW	COP	KW	KW	COP	KW	KW	COP
5.0	614.2	146.5	3.8	592.4	167.7	3.3	574.5	192.6	2.8	560.2	220.7	2.4	548.3	252.2	2.1	417.3	232.1	1.7
6.0	632.1	147.8	3.9	609.1	169.4	3.3	590.6	194.2	2.8	575.6	222.7	2.4	563.2	254.6	2.1	419.8	230.5	1.7
7.0	650.4	149.1	4.0	626.4	170.9	3.4	607.0	195.9	2.9	591.3	224.8	2.5	578.3	257.2	2.1	422.4	229.0	1.7
8.0	669.1	150.3	4.1	643.9	172.2	3.5	623.6	197.8	2.9	607.3	226.8	2.5	593.8	259.7	2.2	425.0	227.4	1.8
9.0	688.0	151.5	4.2	661.9	173.6	3.5	640.7	199.4	3.0	623.7	228.8	2.6	609.6	262.3	2.2	427.6	225.8	1.8
10.0	707.4	152.7	4.2	680.3	175.0	3.6	658.0	201.1	3.1	640.2	231.2	2.6	625.6	265.1	2.2	430.2	224.1	1.8
11.0	727.1	153.9	4.3	698.9	176.3	3.7	675.8	202.8	3.1	657.2	233.2	2.7	641.4	267.3	2.3	432.9	222.5	1.8
12.0	747.1	155.0	4.4	718.0	177.7	3.7	694.0	204.4	3.2	674.5	235.4	2.7	643.5	263.7	2.3	435.3	220.8	1.9
13.0	767.5	156.2	4.5	737.3	179.1	3.8	712.4	206.1	3.2	692.2	237.5	2.8	647.3	260.5	2.4	436.9	219.0	1.9

MODEL YCAS0200EC**AIR TEMPERATURE ON - CONDENSER (C)**

LCWT (°C)	25.0			30.0			35.0			40.0			45.0			50.0		
	KW	KW	COP	KW	KW	COP	KW	KW	COP	KW	KW	COP	KW	KW	COP	KW	KW	COP
5.0	704.4	165.0	3.9	664.8	184.9	3.3	628.2	207.5	2.8	594.7	233.0	2.4	564.4	261.3	2.0	530.7	290.8	1.7
6.0	725.7	167.3	3.9	685.2	187.5	3.3	647.6	210.5	2.8	613.3	236.4	2.4	582.2	265.2	2.0	540.3	291.3	1.8
7.0	747.3	169.5	4.0	705.7	190.1	3.4	667.2	213.5	2.9	632.0	239.8	2.5	600.3	269.1	2.1	544.0	288.9	1.8
8.0	769.2	171.7	4.1	726.5	192.6	3.5	687.1	216.4	2.9	651.1	243.2	2.5	618.6	273.0	2.1	546.0	287.0	1.8
9.0	791.2	173.9	4.1	747.5	195.1	3.5	707.2	219.3	3.0	670.4	246.6	2.5	637.2	277.0	2.2	549.2	285.0	1.8
10.0	813.5	176.0	4.2	768.8	197.6	3.6	727.5	222.3	3.0	689.9	250.1	2.6	656.0	281.0	2.2	552.1	283.2	1.8
11.0	836.1	178.1	4.3	789.4	200.0	3.6	748.1	225.3	3.1	709.6	253.5	2.6	675.0	285.1	2.2	554.9	281.4	1.9
12.0	858.8	180.2	4.3	811.9	202.6	3.7	768.8	228.2	3.1	729.5	257.1	2.7	694.3	289.2	2.3	557.7	279.8	1.9
13.0	881.9	182.2	4.4	833.9	205.1	3.7	788.8	231.1	3.2	749.6	260.6	2.7	713.6	293.4	2.3	560.2	278.2	1.9

MODEL YCAS0210EC**AIR TEMPERATURE ON - CONDENSER (C)**

LCWT (°C)	25.0			30.0			35.0			40.0			45.0			50.0		
	KW	KW	COP	KW	KW	COP	KW	KW	COP	KW	KW	COP	KW	KW	COP	KW	KW	COP
5.0	718.5	168.2	3.9	685.2	190.5	3.3	656.1	216.2	2.8	630.6	245.2	2.4	608.1	277.7	2.1	541.6	291.9	1.8
6.0	739.9	170.0	3.9	705.6	192.6	3.4	675.4	218.6	2.9	649.0	248.1	2.4	625.9	281.0	2.1	544.9	289.6	1.8
7.0	761.6	171.9	4.0	726.2	194.7	3.4	695.0	221.0	2.9	667.8	250.9	2.5	644.0	284.3	2.1	548.4	287.6	1.8
8.0	783.7	173.7	4.1	747.1	196.8	3.5	714.9	223.4	3.0	686.9	253.7	2.5	659.9	286.6	2.2	550.7	285.2	1.8
9.0	806.0	175.5	4.2	768.4	198.8	3.5	735.2	225.8	3.0	706.3	256.5	2.6	675.3	288.6	2.2	553.9	283.1	1.8
10.0	828.8	177.2	4.3	789.9	200.8	3.6	755.8	228.2	3.1	726.0	259.4	2.6	691.0	290.6	2.2	556.3	280.9	1.9
11.0	851.8	178.9	4.3	811.9	202.8	3.7	776.7	230.5	3.1	746.0	262.3	2.7	707.0	292.6	2.3	559.4	278.9	1.9
12.0	875.2	180.6	4.4	834.1	204.8	3.7	797.9	233.0	3.2	766.3	265.2	2.7	723.1	294.7	2.3	562.4	277.0	1.9
13.0	898.9	182.3	4.5	856.7	206.8	3.8	818.7	235.3	3.2	786.9	268.1	2.8	738.9	296.7	2.4	565.3	275.1	1.9

NOTES:

1. kW = Compressor Input Power
2. EER = Chiller EER (includes power from compressors, fans, and control panel's 0.8 KW)
3. LCWT = Leaving Chilled Water Temperature
4. Ratings based on 2.4 GPM cooler water per ton
5. Rated in accordance with ARI Standard 550/590.

Ratings – SI Units - R22

MODEL: YCAS0230EC

AIR TEMPERATURE ON - CONDENSER (°C)																		
LCWT (°C)	25.0			30.0			35.0			40.0			45.0			50.0		
	KW	KW	COP	KW	KW	COP	KW	KW	COP	KW	KW	COP	KW	KW	COP	KW	KW	COP
5.0	754.5	171.3	4.0	726.9	196.1	3.4	704.5	224.8	2.9	686.5	257.5	2.5	671.5	294.0	2.2	562.4	291.4	1.8
6.0	776.6	172.8	4.1	747.7	197.7	3.5	724.3	226.7	3.0	705.5	259.7	2.5	689.8	296.8	2.2	564.4	288.9	1.8
7.0	799.2	174.3	4.2	769.0	199.3	3.5	744.4	228.5	3.0	724.7	262.0	2.6	708.5	299.6	2.2	567.7	286.6	1.9
8.0	822.1	175.7	4.2	790.8	200.9	3.6	765.1	230.4	3.1	744.4	264.2	2.6	722.0	300.0	2.3	570.7	284.1	1.9
9.0	845.5	177.0	4.3	812.9	202.4	3.7	786.2	232.2	3.1	764.5	266.4	2.7	734.7	300.0	2.3	573.9	281.8	1.9
10.0	869.3	178.4	4.4	835.5	203.9	3.8	807.6	234.0	3.2	785.0	268.7	2.7	747.7	300.0	2.4	576.1	279.3	1.9
11.0	893.6	179.7	4.5	858.5	205.5	3.8	829.5	235.8	3.3	805.4	270.9	2.8	761.1	300.0	2.4	579.6	277.0	2.0
12.0	918.3	181.0	4.6	882.0	207.0	3.9	851.9	237.6	3.3	827.3	273.2	2.8	774.3	300.0	2.4	583.0	274.8	2.0
13.0	943.4	182.3	4.7	905.9	208.5	4.0	874.6	239.5	3.4	849.1	275.5	2.9	787.1	300.0	2.5	586.5	272.5	2.0

MODEL: YCAS0250EC

AIR TEMPERATURE ON - CONDENSER (°C)																		
LCWT (°C)	25.0			30.0			35.0			40.0			45.0			50.0		
	KW	KW	COP	KW	KW	COP	KW	KW	COP	KW	KW	COP	KW	KW	COP	KW	KW	COP
5.0	914.2	210.1	4.0	861.3	235.3	3.4	812.4	264.1	2.8	767.8	296.4	2.4	727.7	332.3	2.1	646.2	341.7	1.8
6.0	942.2	213.1	4.0	888.0	238.7	3.4	837.8	268.0	2.9	792.2	300.9	2.5	751.2	337.4	2.1	652.8	337.6	1.8
7.0	970.6	216.1	4.1	915.1	242.1	3.5	863.6	271.9	2.9	816.9	305.4	2.5	775.0	342.6	2.1	659.2	333.5	1.9
8.0	999.5	219.0	4.2	941.8	245.8	3.5	889.7	275.8	3.0	841.9	309.9	2.5	799.1	347.8	2.2	665.3	329.7	1.9
9.0	1028.4	221.9	4.2	969.5	249.1	3.6	916.1	279.7	3.0	867.3	314.4	2.6	823.4	353.0	2.2	671.3	326.0	1.9
10.0	1057.8	224.7	4.3	997.4	252.5	3.6	942.8	283.6	3.1	892.8	319.0	2.6	848.1	358.3	2.2	677.0	322.4	2.0
11.0	1087.4	227.6	4.4	1025.7	255.8	3.7	969.3	287.9	3.1	918.7	323.6	2.7	873.1	363.7	2.3	682.5	319.0	2.0
12.0	1117.3	230.3	4.4	1054.2	259.2	3.8	997.1	292.0	3.2	944.9	328.3	2.7	898.3	369.2	2.3	687.8	315.8	2.0
13.0	1147.5	233.1	4.5	1083.0	262.5	3.8	1024.0	295.9	3.2	970.8	333.4	2.7	923.8	374.8	2.3	692.8	312.6	2.1

MODEL: YCAS0270EC

AIR TEMPERATURE ON - CONDENSER (°C)																		
LCWT (°C)	25.0			30.0			35.0			40.0			45.0			50.0		
	KW	KW	COP	KW	KW	COP	KW	KW	COP	KW	KW	COP	KW	KW	COP	KW	KW	COP
5.0	975.5	234.0	3.8	928.1	264.7	3.2	885.6	300.0	2.8	847.8	339.6	2.4	797.1	371.9	2.0	649.1	345.0	1.8
6.0	1004.7	237.0	3.9	955.8	268.2	3.3	912.0	303.9	2.8	873.2	344.2	2.4	818.6	375.3	2.1	655.1	341.2	1.8
7.0	1034.4	240.0	4.0	983.9	271.5	3.4	938.9	307.9	2.9	898.9	348.9	2.4	838.3	377.4	2.1	661.0	337.4	1.8
8.0	1064.4	242.9	4.0	1012.1	275.1	3.4	966.1	311.8	2.9	925.0	353.5	2.5	856.9	378.8	2.1	666.7	333.7	1.9
9.0	1094.9	245.8	4.1	1041.0	278.5	3.5	993.8	315.8	3.0	951.5	358.2	2.5	875.8	380.3	2.2	672.3	330.2	1.9
10.0	1125.5	248.7	4.2	1070.5	281.9	3.5	1021.7	319.7	3.0	978.4	362.9	2.5	893.8	381.4	2.2	677.7	326.7	2.0
11.0	1156.8	251.5	4.2	1100.1	285.2	3.6	1049.8	324.0	3.0	1003.2	366.1	2.6	912.9	383.0	2.3	682.9	323.3	2.0
12.0	1188.4	254.3	4.3	1130.2	288.6	3.6	1078.6	328.0	3.1	1027.9	369.2	2.6	932.2	384.6	2.3	688.0	320.0	2.0
13.0	1220.3	257.1	4.4	1160.6	292.0	3.7	1107.8	332.2	3.1	1052.7	372.6	2.7	951.7	386.3	2.3	692.9	316.8	2.1

NOTES:

1. kW = Compressor Input Power
2. EER = Chiller EER (includes power from compressors, fans, and control panel's 0.8 KW)
3. LCWT = Leaving Chilled Water Temperature
4. Ratings based on 2.4 GPM cooler water per ton
5. Rated in accordance with ARI Standard 550/590.

MODEL: YCAS0300EC

LCWT (°C)	AIR TEMPERATURE ON - CONDENSER (°C)																	
	25.0			30.0			35.0			40.0			45.0			50.0		
	KW	KW	COP	KW	KW	COP	KW	KW	COP	KW	KW	COP	KW	KW	COP	KW	KW	COP
5.0	1091.1	254.3	3.9	1027.7	284.8	3.3	969.8	319.3	2.8	916.8	358.2	2.4	869.0	401.5	2.0	772.1	411.1	1.8
6.0	1124.4	258.0	4.0	1059.5	289.1	3.4	999.9	324.3	2.9	945.8	363.8	2.4	896.9	407.8	2.1	783.4	408.1	1.8
7.0	1158.3	261.7	4.0	1091.6	293.3	3.4	1030.5	329.2	2.9	975.1	369.3	2.5	925.2	414.2	2.1	790.5	402.7	1.9
8.0	1191.1	265.2	4.1	1124.1	297.5	3.5	1061.4	334.0	3.0	1004.8	375.1	2.5	953.8	420.6	2.1	796.1	398.0	1.9
9.0	1227.0	269.0	4.2	1156.8	301.7	3.5	1092.8	338.9	3.0	1034.8	380.8	2.6	982.3	426.8	2.2	802.8	393.4	1.9
10.0	1261.7	272.6	4.2	1189.9	305.9	3.6	1124.5	343.9	3.1	1065.2	386.5	2.6	1005.5	429.0	2.2	809.0	388.8	2.0
11.0	1296.9	276.1	4.3	1223.0	310.1	3.7	1156.5	348.8	3.1	1095.9	392.3	2.6	1027.4	431.0	2.3	815.0	384.6	2.0
12.0	1332.4	279.6	4.4	1257.5	314.4	3.7	1188.9	353.8	3.1	1127.1	398.2	2.7	1050.2	433.3	2.3	820.9	380.5	2.0
13.0	1368.2	283.2	4.4	1291.7	318.6	3.8	1221.7	358.9	3.2	1158.4	404.1	2.7	1072.8	435.5	2.3	826.3	376.4	2.1

MODEL: YCAS0330EC

LCWT (°C)	AIR TEMPERATURE ON - CONDENSER (°C)																	
	25.0			30.0			35.0			40.0			45.0			50.0		
	KW	KW	COP	KW	KW	COP	KW	KW	COP	KW	KW	COP	KW	KW	COP	KW	KW	COP
5.0	1133.6	265.9	3.9	1092.9	304.7	3.3	1059.3	349.4	2.8	1032.2	400.3	2.4	990.7	444.2	2.1	795.8	399.1	1.9
6.0	1168.2	268.5	4.0	1123.1	307.3	3.4	1089.2	352.7	2.9	1060.7	404.2	2.5	1014.6	446.6	2.2	800.2	393.7	1.9
7.0	1203.0	271.0	4.1	1154.8	310.0	3.4	1119.9	356.0	2.9	1090.0	408.2	2.5	1036.3	447.4	2.2	806.4	389.1	2.0
8.0	1237.0	273.4	4.1	1189.5	312.9	3.5	1150.9	359.2	3.0	1119.8	412.1	2.6	1053.9	445.6	2.2	812.1	384.4	2.0
9.0	1272.4	275.7	4.2	1223.0	315.6	3.6	1182.8	362.4	3.1	1150.3	416.1	2.6	1070.3	443.1	2.3	817.3	379.4	2.0
10.0	1308.5	278.0	4.3	1257.2	318.3	3.7	1215.3	365.6	3.1	1179.5	419.1	2.7	1088.1	441.1	2.3	823.5	374.9	2.1
11.0	1345.2	280.3	4.4	1292.0	321.0	3.7	1248.4	368.8	3.2	1206.6	421.3	2.7	1105.7	439.1	2.4	829.7	370.4	2.1
12.0	1382.5	282.6	4.5	1327.5	323.7	3.8	1282.2	372.1	3.2	1236.2	423.7	2.8	1123.8	437.1	2.4	835.8	366.0	2.1
13.0	1420.4	284.9	4.6	1363.6	326.4	3.9	1316.5	375.5	3.3	1267.8	426.0	2.8	1142.0	435.1	2.5	842.0	361.5	2.2

MODEL: YCAS0360EC

LCWT (°C)	AIR TEMPERATURE ON - CONDENSER (°C)																	
	25.0			30.0			35.0			40.0			45.0			50.0		
	KW	KW	COP	KW	KW	COP	KW	KW	COP	KW	KW	COP	KW	KW	COP	KW	KW	COP
5.0	1322.5	317.8	3.8	1246.6	356.1	3.2	1176.9	399.4	2.8	1113.1	448.3	2.3	1055.8	502.5	2.0	866.2	466.9	1.8
6.0	1362.7	322.6	3.9	1284.8	361.6	3.3	1213.2	405.9	2.8	1148.2	455.4	2.4	1088.0	510.2	2.0	874.3	461.8	1.8
7.0	1403.0	327.4	3.9	1323.3	367.2	3.3	1250.0	412.2	2.8	1183.7	462.6	2.4	1123.8	518.9	2.1	882.3	456.7	1.8
8.0	1444.3	332.2	4.0	1362.2	372.8	3.4	1287.5	418.6	2.9	1219.3	470.2	2.4	1158.5	527.3	2.1	889.9	451.9	1.9
9.0	1485.7	336.9	4.1	1401.7	378.3	3.4	1325.2	425.0	2.9	1255.6	477.6	2.5	1193.7	535.8	2.1	897.2	447.4	1.9
10.0	1527.5	341.6	4.1	1441.6	383.8	3.5	1363.4	431.4	3.0	1292.3	485.0	2.5	1219.5	537.5	2.2	904.2	443.0	1.9
11.0	1569.9	346.3	4.2	1481.9	389.3	3.5	1401.6	438.1	3.0	1329.5	492.6	2.6	1240.3	536.1	2.2	911.0	438.9	2.0
12.0	1612.2	350.9	4.3	1522.7	394.9	3.6	1440.6	444.7	3.0	1366.9	500.3	2.6	1262.0	536.5	2.2	917.6	434.9	2.0
13.0	1655.5	355.6	4.3	1563.7	400.5	3.6	1480.0	451.3	3.1	1404.4	508.4	2.6	1283.4	536.2	2.3	923.7	431.0	2.0

NOTES:

1. kW = Compressor Input Power
2. EER = Chiller EER (includes power from compressors, fans, and control panel's 0.8 KW)
3. LCWT = Leaving Chilled Water Temperature
4. Ratings based on 2.4 GPM cooler water per ton
5. Rated in accordance with ARI Standard 550/590.

Ratings – SI Units - R22

MODEL: YCAS0400EC

LCWT (°C)	AIR TEMPERATURE ON - CONDENSER (°C)																	
	25.0			30.0			35.0			40.0			45.0			50.0		
	KW	KW	COP	KW	KW	COP	KW	KW	COP	KW	KW	COP	KW	KW	COP	KW	KW	COP
5.0	1461.3	343.3	3.9	1376.8	384.6	3.3	1299.8	431.2	2.8	1228.0	483.6	2.4	1165.6	541.9	2.0	995.9	529.4	1.8
6.0	1505.8	348.5	4.0	1419.1	390.5	3.4	1339.5	438.1	2.9	1265.9	491.0	2.4	1202.6	550.8	2.1	1011.9	527.1	1.8
7.0	1550.8	353.6	4.0	1462.6	396.5	3.4	1380.5	444.9	2.9	1306.9	499.0	2.5	1240.4	559.7	2.1	1021.3	520.7	1.9
8.0	1596.2	358.7	4.1	1505.3	402.3	3.5	1421.9	451.7	2.9	1346.3	507.1	2.5	1278.8	568.6	2.1	1028.7	514.7	1.9
9.0	1642.2	363.7	4.2	1549.1	408.1	3.5	1463.7	458.5	3.0	1386.3	515.0	2.5	1314.9	575.8	2.2	1037.1	509.0	1.9
10.0	1688.6	368.7	4.2	1593.1	413.9	3.6	1506.6	465.4	3.0	1427.1	523.0	2.6	1340.1	575.2	2.2	1045.0	503.4	2.0
11.0	1735.4	373.7	4.3	1637.6	419.8	3.6	1548.7	472.2	3.1	1468.2	531.1	2.6	1363.8	575.2	2.2	1053.1	498.3	2.0
12.0	1782.8	378.6	4.3	1683.1	425.7	3.7	1592.0	479.2	3.1	1509.6	539.2	2.6	1389.3	575.5	2.3	1060.3	493.2	2.0
13.0	1830.4	383.6	4.4	1728.7	431.7	3.7	1635.6	486.2	3.2	1551.6	547.6	2.7	1414.1	575.8	2.3	1067.1	488.3	2.1

MODEL: YCAS0440EC

LCWT (°C)	AIR TEMPERATURE ON - CONDENSER (°C)																	
	25.0			30.0			35.0			40.0			45.0			50.0		
	KW	KW	COP	KW	KW	COP	KW	KW	COP	KW	KW	COP	KW	KW	COP	KW	KW	COP
5.0	1510.2	360.4	3.8	1455.5	413.1	3.3	1412.0	474.0	2.8	1376.5	543.0	2.4	1305.6	593.4	2.1	1018.0	516.7	1.9
6.0	1554.4	363.9	3.9	1497.4	417.0	3.3	1451.6	478.6	2.8	1414.5	548.7	2.4	1335.1	594.7	2.1	1024.0	510.2	1.9
7.0	1599.4	367.4	4.0	1540.0	420.9	3.4	1492.4	483.2	2.9	1453.3	554.3	2.5	1359.2	593.4	2.2	1031.9	504.4	1.9
8.0	1645.3	370.8	4.1	1583.5	424.8	3.5	1533.2	487.8	3.0	1492.9	559.9	2.5	1380.7	590.2	2.2	1039.4	498.5	2.0
9.0	1692.1	374.1	4.2	1627.8	428.6	3.5	1575.6	492.4	3.0	1533.0	565.5	2.6	1398.5	585.5	2.3	1046.0	492.5	2.0
10.0	1739.7	377.4	4.3	1673.0	432.4	3.6	1618.5	497.0	3.1	1569.6	568.4	2.6	1418.4	581.4	2.3	1053.9	486.8	2.0
11.0	1788.2	380.6	4.3	1719.0	436.3	3.7	1662.4	501.6	3.1	1605.5	570.7	2.7	1438.6	577.4	2.4	1061.8	481.2	2.1
12.0	1837.5	383.9	4.4	1765.9	440.2	3.7	1707.0	506.4	3.2	1642.3	573.0	2.7	1459.1	573.4	2.4	1069.5	475.7	2.1
13.0	1887.6	387.2	4.5	1813.6	444.1	3.8	1752.5	511.2	3.2	1680.2	575.3	2.8	1479.7	569.5	2.5	1077.2	470.1	2.1

NOTES:

1. kW = Compressor Input Power
2. EER = Chiller EER (includes power from compressors, fans, and control panel's 0.8 KW)
3. LCWT = Leaving Chilled Water Temperature
4. Ratings based on 2.4 GPM cooler water per ton
5. Rated in accordance with ARI Standard 550/590.

INTENTIONALLY LEFT BLANK

Physical Data

ENGLISH UNITS

	MODEL NUMBER YCAS								
	0130EC	0140EC	0150EC	0160EC	0170EC	0180EC	0200EC	0210EC	0230EC
General Unit Data									
Unit Capacity at ARI Conditions, Tons	121.1	130.1	145.3	157.1	164.3	171.6	186.7	194.8	209.1
Number of Independent Refrigerant Circuits	2	2	2	2	2	2	2	2	2
Refrigerant Charge, R-22, Ckt.-1 / Ckt.-2, lbs.	180 / 180	180 / 180	180 / 190	190 / 190	190 / 190	190/190	220/220	220/220	220/220
Oil Charge, Ckt.-1 / Ckt.-2, gallons	5 / 5	5 / 5	5 / 5	5 / 5	5 / 5	5 / 5	5 / 5	5 / 5	5 / 5
Shipping Weight:									
Aluminum Fin Coils, lbs.	9,888	10,110	10,599	10,583	10,694	10,805	11,849	11,970	12,081
Copper Fin Coils, lbs.	11,154	11,376	11,865	11,849	11,960	12,071	13,441	13,552	13,663
Operating Weight:									
Aluminum Fin Coils, lbs.	10,315	10,537	11,263	11,247	11,358	11,469	12,513	12,634	12,745
Copper Fin Coils, lbs.	11,581	11,803	12,529	12,513	12,624	12,735	14,105	14,216	14,327
Compressors, DXS Semihermetic Twin Screw									
Quantity per Chiller	2	2	2	2	2	2	2	2	2
Nominal Ton Size, Ckt.-1 / Ckt.-2	62 / 62	68 / 68	78 / 68	78 / 78	85 / 78	85/85	95/95	105/95	105/105
Refrigerant Economizer, Ckt.-1 / Ckt.-2	No / No	Yes / Yes	No / Yes	No / No	Yes / No	Yes / Yes	No / No	Yes / No	Yes / Yes
Condensers, High Efficiency Fin / Tube with Integral Subcooler									
Total Chiller Coil Face Area, ft ²	256	256	256	256	256	256	320	320	320
Number of Rows	3	3	3	3	3	3	3	3	3
Fins per Inch	13	13	13	13	13	13	13	13	13
CONDENSER FANS									
Number, Ckt.-1 / Ckt.-2	4 / 4	4 / 4	4 / 4	4 / 4	4 / 4	4 / 4	5 / 5	5 / 5	5 / 5
Standard Fans									
Fan Motor, HP / kW	2 / 1.8	2 / 1.8	2 / 1.8	2 / 1.8	2 / 1.8	2 / 1.8	2 / 1.8	2 / 1.8	2 / 1.8
Fan & Motor RPM	1140	1140	1140	1140	1140	1140	1140	1140	1140
Fan Diameter, inches	35.4	35.4	35.4	35.4	35.4	35.4	35.4	35.4	35.4
Fan Tip Speed, feet/min.	10,575	10,575	10,575	10,575	10,575	10,575	10,575	10,575	10,575
Total Chiller Airflow, CFM	114,400	114,400	114,400	114,400	114,400	114,400	143,000	143,000	143,000
Low Noise Fans									
Fan Motor, HP / kW	2 / 1.53	2 / 1.53	2 / 1.53	2 / 1.53	2 / 1.53	2 / 1.8	2 / 1.8	2 / 1.8	2 / 1.8
Fan & Motor Speed, RPM	840	840	840	840	840	1140	1140	1140	1140
Fan Diameter, inches	35.4	35.4	35.4	35.4	35.4	35.4	35.4	35.4	35.4
Fan Tip Speed, feet/min.	7,792	7,792	7,792	7,792	7,792	10,575	10,575	10,575	10,575
Total Chiller Airflow, cfm	112,400	112,400	112,400	112,400	112,400	114,400	143,000	143,000	143,000
High Static Fans									
Fan Motor, HP / kW	5 / 3.79	5 / 3.79	5 / 3.79	5 / 3.79	5 / 3.79	5 / 3.79	5 / 3.79	5 / 3.79	5 / 3.79
Fan & Motor RPM	1140	1140	1140	1140	1140	1,140	1,140	1,140	1,140
Fan Diameter, inches	35.4	35.4	35.4	35.4	35.4	35.4	35.4	35.4	35.4
Fan Tip Speed, feet/min.	10,575	10,575	10,575	10,575	10,575	10,575	10,575	10,575	10,575
Total Chiller Airflow, CFM (@0.4" additional static)	114,400	114,400	114,400	114,400	114,400	114,400	143,000	143,000	143,000
Evaporator, Direct Expansion									
Water Volume, gallons	53	53	55	55	55	55	79	79	79
Maximum ¹ Water Side Pressure, PSIG	150	150	150	150	150	150	150	150	150
Maximum Refrigerant Side Pressure, PSIG	350	350	350	350	350	350	350	350	350
Minimum Chilled Water Flow Rate, GPM	138	138	200	200	200	200	250	250	250
Maximum Chilled Water Flow Rate, GPM	525	525	600	600	600	600	750	750	750
Water Connections, inches	8	8	8	8	8	8	8	8	8

¹ Optional 300 PSIG Waterside available

ENGLISH UNITS

	MODEL NUMBER YCAS						
	0250EC	0270EC	0300EC	0330EC	0360EC	0400EC	0440EC
General Unit Data							
Unit Capacity at ARI Conditions, Tons	243.3	264.5	287.7	314.1	352.2	386.3	419.1
Number of Independent Refrig. Circuits	3	3	3	3	4	4	4
Refrig. Charge, R-22, Ckt.-1 / Ckt.-2, lbs.	154/154	154/154	187/187	203/203	187/187	212/212	229/229
Ckt-3 / Ckt-4, lbs.	154 / -	172 / -	176 / -	190 / -	187/187	198/198	216/216
Oil Charge, Ckt.-1 / Ckt.-2, gallons	5 / 5	5 / 5	5 / 5	5 / 5	5 / 5	5 / 5	5 / 5
Ckt.-3, Ckt.-4, gallons	5 / -	5 / -	5 / -	5 / -	5 / 5	5 / 5	5 / 5
Shipping Weight:							
Aluminum Fin Coils, lbs.	15,022	15,190	16,570	16,748	21,164	22,476	22,926
Copper Fin Coils, lbs.	16,922	17,090	18,785	18,964	23,695	25,322	25,772
Operating Weight:							
Aluminum Fin Coils, lbs.	17,334	17,531	18,896	19,251	24,191	25,564	26,049
Copper Fin Coils, lbs.	19,235	19,431	21,111	21,466	26,722	28,411	28,896
Compressors, DXS Semihermetic Twin Screw							
Quantity per Chiller	3	3	3	3	4	4	4
Nominal Ton Size, Ckt.-1 / Ckt.-2	78/78	78/78	95/95	105/105	95/95	95/95	105/105
Ckt.-3 / Ckt.-4	78 / -	105 / -	95 / -	105 / -	78/78	95/95	105/105
Refrigerant Economizer, Ckt.-1 / Ckt.-2	No / No	No / No	No / No	Yes / Yes	No / No	No / No	Yes / Yes
Ckt.-3 / Ckt.-4	No / -	Yes / -	No / -	Yes / -	No / No	No / No	Yes / Yes
Condensers, High Efficiency Fin / Tube with Integral Subcooler							
Total Chiller Coil Face Area, ft ²	384	384	448	448	512	576	576
Number of Rows	3	3	3	3	3	3	3
Fins per Inch	13	13	13	13	13	13	13
Condenser Fans							
Number, Ckt.-1 / Ckt.-2	4 / 4	4 / 4	5 / 5	5 / 5	4 / 4	5 / 5	5 / 5
Number, Ckt.-3 / Ckt.-4	4 / -	4 / -	4 / -	4 / -	4 / 4	4 / 4	4 / 4
Standard Fans							
Fan Motor, HP / kW	2 / 1.8	2 / 1.8	2 / 1.8	2 / 1.8	2 / 1.8	2 / 1.8	2 / 1.8
Fan & Motor RPM	1140	1140	1140	1140	1140	1140	1140
Fan Diameter, inches	35.4	35.4	35.4	35.4	35.4	35.4	35.4
Fan Tip Speed, feet/min.	10,575	10,575	10,575	10,575	10,575	10,575	10,575
Total Chiller Airflow, CFM	171,600	171,600	200,200	200,200	228,800	257,400	257,400
Low Noise Fans							
Fan Motor, HP / kW	2 / 1.53	2 / 1.53	2 / 1.53	2 / 1.53	2 / 1.53	2 / 1.53	2 / 1.53
Fan & Motor RPM	840	840	840	840	840	840	840
Fan Diameter, inches	35.4	35.4	35.4	35.4	35.4	35.4	35.4
Fan Tip Speed, feet/min.	7,792	7,792	7,792	7,792	7,792	7,792	7,792
Total Chiller Airflow, CFM	168,600	168,600	196,700	196,700	224,800	252,900	252,900
High Static Fans							
Fan Motor, HP / kW	5 / 3.79	5 / 3.79	5 / 3.79	5 / 3.79	5 / 3.79	5 / 3.79	5 / 3.79
Fan & Motor RPM	1,140	1,140	1,140	1,140	1,140	1,140	1,140
Fan Diameter, inches	35.4	35.4	35.4	35.4	35.4	35.4	35.4
Fan Tip Speed, feet/min.	10,575	10,575	10,575	10,575	10,575	10,575	10,575
Total Chiller Airflow, CFM (@0.4" additional static)	171,600	171,600	200,200	200,200	228,800	257,400	257,400
Evaporator, Direct Expansion							
Water Volume, gallons	116	116	94	94	150	135	135
Maximum ¹ Water Side Pressure, PSIG	150	150	150	150	150	150	150
Maximum Refrigerant Side Pressure, PSIG	300	300	300	300	300	300	300
Minimum Chilled Water Flow Rate, GPM	225	225	255	255	300	330	330
Maximum Chilled Water Flow Rate, GPM	800	800	800	800	1060	1060	1060
Water Connections, inches	10	10	10	10	10	10	10

¹ Optional 300 PSIG Waterside available

Physical Data

SI UNITS

MODEL NUMBER YCAS									
	0130EC	0140EC	0150EC	0160EC	0170EC	0180EC	0200EC	0210EC	0230EC
General Unit Data									
Unit Capacity at 6.7°C water & 35°C ambient, kW	425.7	457.6	510.9	552.6	578.0	603.4	656.6	685.2	735.2
Number of Independent Refrigerant Circuits	2	2	2	2	2	2	2	2	2
Refrigerant Charge, R-22, Ckt.-1 / Ckt.-2, kg.	82 / 82	82 / 82	82 / 86	86 / 86	86 / 86	86 / 86	100 / 100	100 / 100	100 / 100
Oil Charge, Ckt.-1 / Ckt.-2, liters	19 / 19	19 / 19	19 / 19	19 / 19	19 / 19	19 / 19	19 / 19	19 / 19	19 / 19
Shipping Weight:									
Aluminum Fin Coils, kg.	4,484	4,585	4,807	4,800	4,850	4,900	5,374	5,429	5,479
Copper Fin Coils, kg.	5,059	5,159	5,381	5,374	5,424	5,474	6,096	6,146	6,196
Operating Weight:									
Aluminum Fin Coils, kg.	4,679	4,780	5,109	5,102	5,152	5,202	5,676	5,731	5,781
Copper Fin Coils, kg.	5,253	5,354	5,683	5,676	5,726	5,777	6,398	6,448	6,499
Compressors, DXS Semihermetic Twin Screw									
Quantity per Chiller	2	2	2	2	2	2	2	2	2
Nominal kW Size, Ckt.-1 / Ckt.-2	220 / 220	240 / 240	275 / 240	275 / 275	300 / 275	300/300	335/335	370/335	370/370
Refrigerant Economizer, Ckt.-1 / Ckt.-2	No / No	Yes / Yes	No / Yes	No / No	Yes / No	Yes / Yes	No / No	Yes / No	Yes / Yes
Condensers, High Efficiency Fin / Tube with Integral Subcooler									
Total Chiller Coil Face Area, m ²	23.78	23.78	23.78	23.78	23.78	23.78	29.73	29.73	29.73
Number of Rows	3	3	3	3	3	3	3	3	3
Fins per Meter	512	512	512	512	512	512	512	512	512
CONDENSER FANS									
Number, Ckt.-1 / Ckt.-2	4 / 4	4 / 4	4 / 4	4 / 4	4 / 4	4 / 4	5 / 5	5 / 5	5 / 5
Standard Fans									
Fan Motor, HP / kW	2 / 1.8	2 / 1.8	2 / 1.8	2 / 1.8	2 / 1.8	2 / 1.8	2 / 1.8	2 / 1.8	2 / 1.8
Fan & Motor Speed, rev./sec.	19.0	19.0	19.0	19.0	19.0	19.0	19.0	19.0	19.0
Fan Diameter, mm	900	900	900	900	900	900	900	900	900
Fan Tip Speed, m/sec.	40	40	40	40	40	54	54	54	54
Total Chiller Airflow, l/sec.	53,989	53,989	53,989	53,989	53,989	53,989	67,486	67,486	67,486
Low Noise Fans									
Fan Motor, HP / kW	2 / 1.53	2 / 1.53	2 / 1.53	2 / 1.53	2 / 1.53	2 / 1.53	2 / 1.53	2 / 1.53	2 / 1.53
Fan & Motor Speed, rev./sec.	14	14	14	14	14	14	14	14	14
Fan Diameter, mm	900	900	900	900	900	900	900	900	900
Fan Tip Speed, m/sec.	40	40	40	40	40	40	40	40	40
Total Chiller Airflow, l/sec.	53,045	53,045	53,045	53,045	53,045	53,045	66,307	66,307	66,307
High Static Fans									
Fan Motor, HP / kW	5 / 3.79	5 / 3.79	5 / 3.79	5 / 3.79	5 / 3.79	5 / 3.79	5 / 3.79	5 / 3.79	5 / 3.79
Fan Diameter, mm	900	900	900	900	900	19.0	19.0	19.0	19.0
Fan Tip Speed, m/sec.	54	54	54	54	54	900	900	900	900
Total Chiller Airflow, l/sec. (@0.4" additional static)	53,989	53,989	53,989	53,989	53,989	54	54	54	54
Fan & Motor Speed, rev./sec.	19.0	19.0	19.0	19.0	19.0	53,989	67,486	67,486	67,486
Evaporator, Direct Expansion									
Water Volume, liters	200	200	208	208	208	208	299	299	299
Maximum ¹ Water Side Pressure, Bar	10	10	10	10	10	10	10	10	10
Maximum Refrigerant Side Pressure, Bar	24	24	24	24	24	24	24	24	24
Minimum Chilled Water Flow Rate, l/sec.	8.7	8.7	12.6	12.6	12.6	12.6	15.8	15.8	15.8
Maximum Chilled Water Flow Rate, l/sec.	33.1	33.1	37.9	37.9	37.9	37.9	47.3	47.3	47.3
Water Connections, inches	8	8	8	8	8	8	8	8	8

¹ Optional 21 Bar Waterside available

SI UNITS

MODEL NUMBER YCAS							
	0250EC	0270EC	0300EC	0330EC	0360EC	0400EC	0440EC
General Unit Data							
Unit Capacity at 6.7°C water & 35°C ambient, kW	855.6	930.3	1011.3	1104.7	1238.5	1358.7	1474.1
Number of Independent Refrigerant Circuits	3	3	3	3	4	4	4
Refrig. Charge, R-22,Ckt.-1 / Ckt.-2, kg.	70 / 70	70 / 70	85 / 85	92 / 92	85 / 85	96 / 96	104 / 104
Ckt.-3 / Ckt.-4, kg.	70 / -	78 / -	80 / -	86 / -	85 / 85	90 / 90	98 / 98
Oil Charge, Ckt.-1 / Ckt.-2, liters	19 / 19	19 / 19	19 / 19	19 / 19	19 / 19	19 / 19	19 / 19
Ckt.-3, Ckt.-4, liters	19 / -	19 / -	19 / -	19 / -	19 / 19	19 / 19	19 / 19
Shipping Weight:							
Aluminum Fin Coils, kg.	6,814	6,890	7,516	7,597	9,600	10,195	10,399
Copper Fin Coils, kg.	7,676	7,752	8,521	8,602	10,748	11,486	11,690
Operating Weight:							
Aluminum Fin Coils, kg.	7,863	7,952	8,571	8,732	10,973	11,596	11,816
Copper Fin Coils, kg.	8,725	8,814	9,576	9,737	12,121	12,887	13,107
Compressors, DXS Semihermetic Twin Screw							
Quantity per Chiller	3	3	3	3	4	4	4
Nominal kW Size, Ckt.-1 / Ckt.-2	275/275	275/275	335/335	370/370	335/335	335/335	370/370
Ckt.-3 / Ckt.-4	275 / -	370 / -	335 / -	370 / -	275/275	335/335	370/370
Refrigerant Economizer, Ckt.-1 / Ckt.-2	No / No	No / No	No / No	Yes / Yes	No / No	No / No	Yes / Yes
Ckt.-3 / Ckt.-4	No / -	Yes / -	No / -	Yes / -	No / No	No / No	Yes / Yes
Condensers, High Efficiency Fin / Tube with Integral Subcooler							
Total Chiller Coil Face Area, m ²	35.67	35.67	41.62	41.62	47.57	53.51	53.51
Number of Rows	3	3	3	3	3	3	3
Fins per Meter	512	512	512	512	512	512	512
Condenser Fans							
Number, Ckt.-1 / Ckt.-2	4 / 4	4 / 4	5 / 5	5 / 5	4 / 4	5 / 5	5 / 5
Number, Ckt.-3 / Ckt.-4	4 / -	4 / -	4 / -	4 / -	4 / 4	4 / 4	4 / 4
Standard Fans							
Fan Motor, HP / kW	2 / 1.8	2 / 1.8	2 / 1.8	2 / 1.8	2 / 1.8	2 / 1.8	2 / 1.8
Fan & Motor speed, rev./sec.	19.0	19.0	19.0	19.0	19.0	19.0	19.0
Fan Diameter, mm	900	900	900	900	900	900	900
Fan Tip Speed, m/sec.	54	54	54	54	54	54	54
Total Chiller Airflow, l/sec.	80,983	80,983	94,481	94,481	107,978	121,475	121,475
Low Noise Fans							
Fan Motor, HP / kW	2 / 1.53	2 / 1.53	2 / 1.53	2 / 1.53	2 / 1.53	2 / 1.53	2 / 1.53
Fan & Motor Speed, rev./sec.	14	14	14	14	14	14	14
Fan Diameter, mm	900	900	900	900	900	900	900
Fan Tip Speed, m/sec.	40	40	40	40	40	40	40
Total Chiller Airflow, l/sec.	79,568	79,568	92,829	92,829	106,091	119,352	119,352
High Static Fans							
Fan Motor, HP / kW	5 / 3.79	5 / 3.79	5 / 3.79	5 / 3.79	5 / 3.79	5 / 3.79	5 / 3.79
Fan & Motor Speed, rev./sec.	19.0	19.0	19.0	19.0	19.0	19.0	19.0
Fan Diameter, mm	900	900	900	900	900	900	900
Fan Tip Speed, m/sec.	54	54	54	54	54	54	54
Total Chiller Airflow, l/sec. (@0.4" additional static)	80,983	80,983	94,481	94,481	107,978	121,475	121,475
Evaporator, Direct Expansion							
Water Volume, liters	439	439	355	355	567	511	511
Maximum ¹ Water Side Pressure, Bar	10	10	10	10	10	10	10
Maximum Refrigerant Side Pressure, Bar	20.7	20.7	20.7	20.7	20.7	20.7	20.7
Minimum Chilled Water Flow Rate, l/sec.	14	14	16	16	19	21	21
Maximum Chilled Water Flow Rate, l/sec.	50	50	50	50	67	67	67
Water Connections, inches	10	10	10	10	10	10	10

¹ Optional 21 Bar Waterside available

Dimensions – YCAS0130 - 0180 (English)

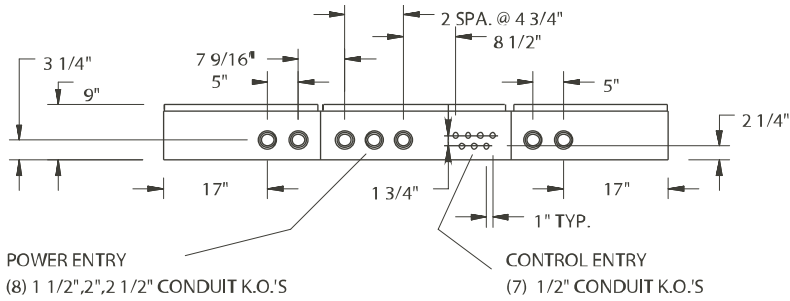

VIEW B-B

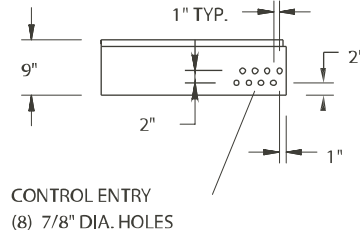

VIEW C-C

LD03742a

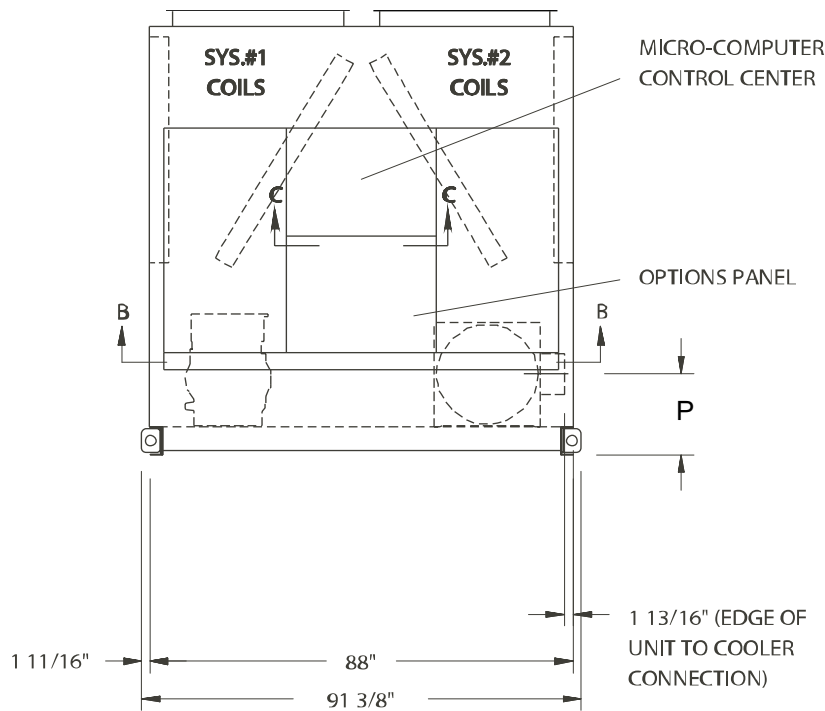

LD03742

VIEW A-A

DIMENSION	MODELS	MODELS
	130 - 140	150 - 180
P	17-1/4"	18"

NOTES:

1. Placement on a level surface free of obstructions (including snow, for winter operation) or air recirculation ensures rated performance, reliable operation and ease of maintenance. Site restrictions may compromise minimum clearances indicated below, resulting in unpredictable air flow patterns and possible diminished performance. YORK's unit controls will optimize operation without nuisance high pressure safety cutout; however, the system designer must consider potential performance degradation. Access to the unit control center assumes the unit is no higher than on spring isolators. Recommended minimum clearances: Side to wall - 6'; rear to wall - 6'; control panel end to wall - 4'; top - no obstructions allowed; distance between adjacent units - 10'. No more than one adjacent wall may be higher than the unit.

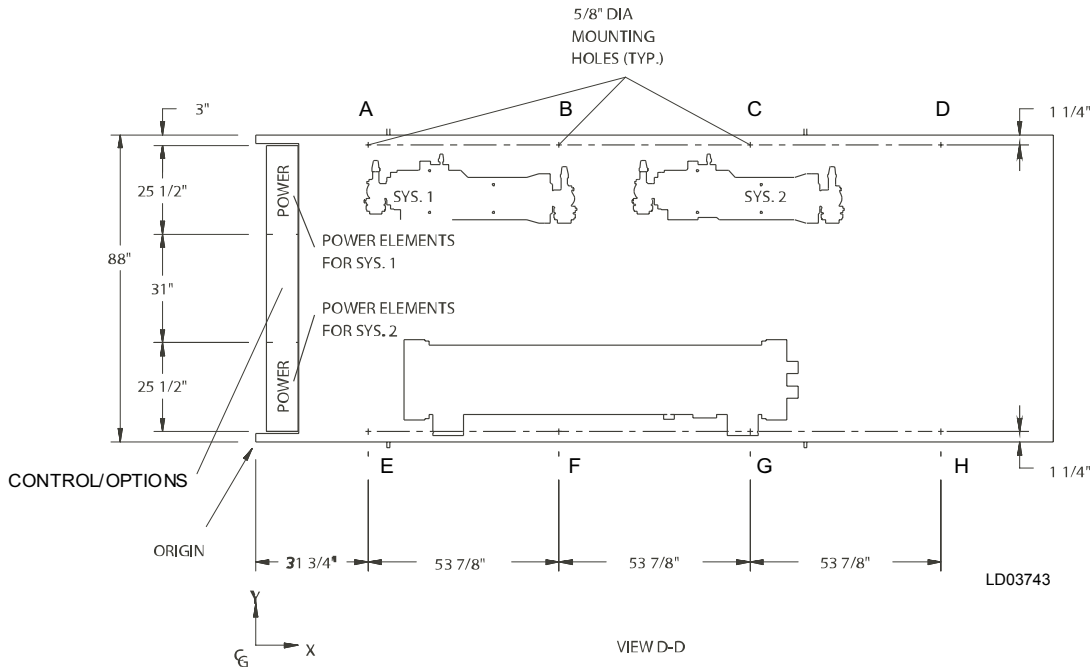

CENTER OF GRAVITY (Alum.)

YCAS	X	Y	Z
0130	101.3"	44.4"	37.8"
0140	101.3"	44.4"	37.8"
0150	106.7"	42.8"	36.2"
0160	107.0"	43.0"	36.2"
0170	107.0"	43.0"	36.2"
0180	107.0"	43.0"	36.2"

CENTER OF GRAVITY (Copper)

YCAS	X	Y	Z
0130	103.5"	44.4"	40.7"
0140	103.5"	44.4"	40.7"
0150	108.2"	43.0"	39.2"
0160	108.4"	43.1"	39.1"
0170	108.4"	43.1"	39.1"
0180	108.4"	43.1"	39.1"

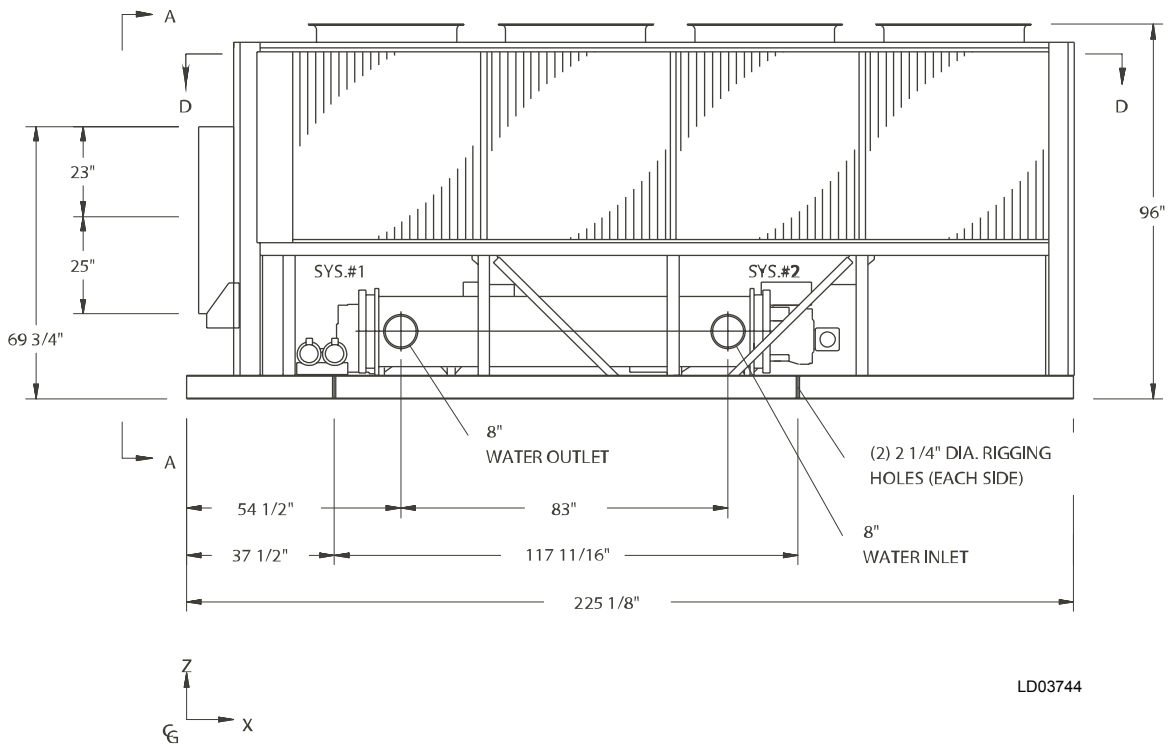

Dimensions – YCAS0130 - 0180 (SI)

All dimensions are in mm unless otherwise noted.

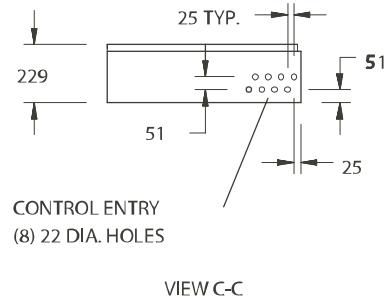
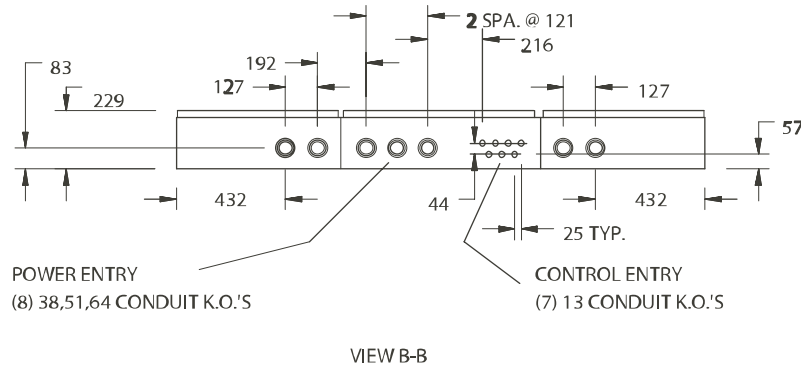

LD03745a

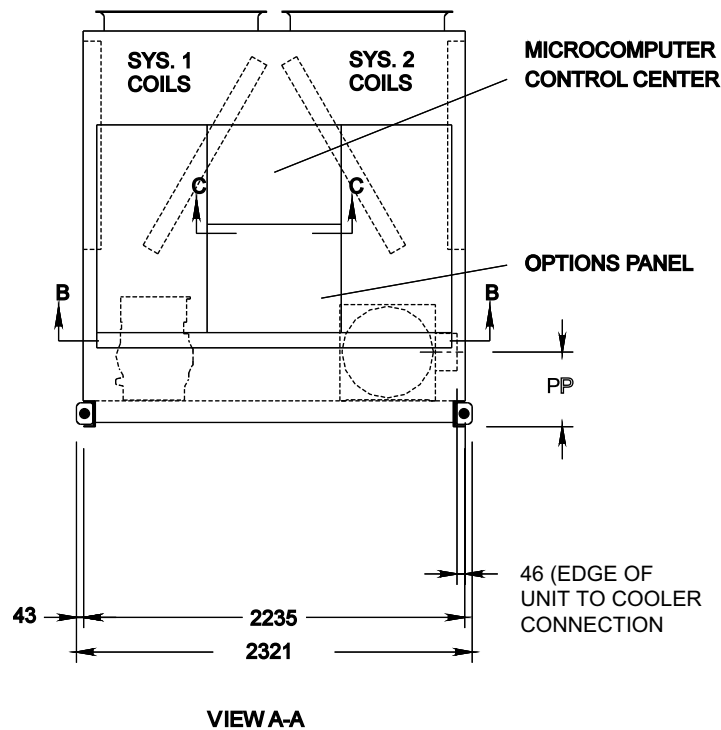

DIMENSION	MODELS 130 - 140	MODELS 150 - 180
P	438	457

NOTES:

1. Placement on a level surface free of obstructions (including snow, for winter operation) or air recirculation ensures rated performance, reliable operation and ease of maintenance. Site restrictions may compromise minimum clearances indicated below, resulting in unpredictable air flow patterns and possible diminished performance. YORK's unit controls will optimize operation without nuisance high pressure safety cutout; however, the system designer must consider potential performance degradation. Access to the unit control center assumes the unit is no higher than on spring isolators. Recommended minimum clearances: Side to wall - 2m; rear to wall - 2m; control panel end to wall - 1.2m; top - no obstructions allowed; distance between adjacent units - 3m. No more than one adjacent wall may be higher than the unit.

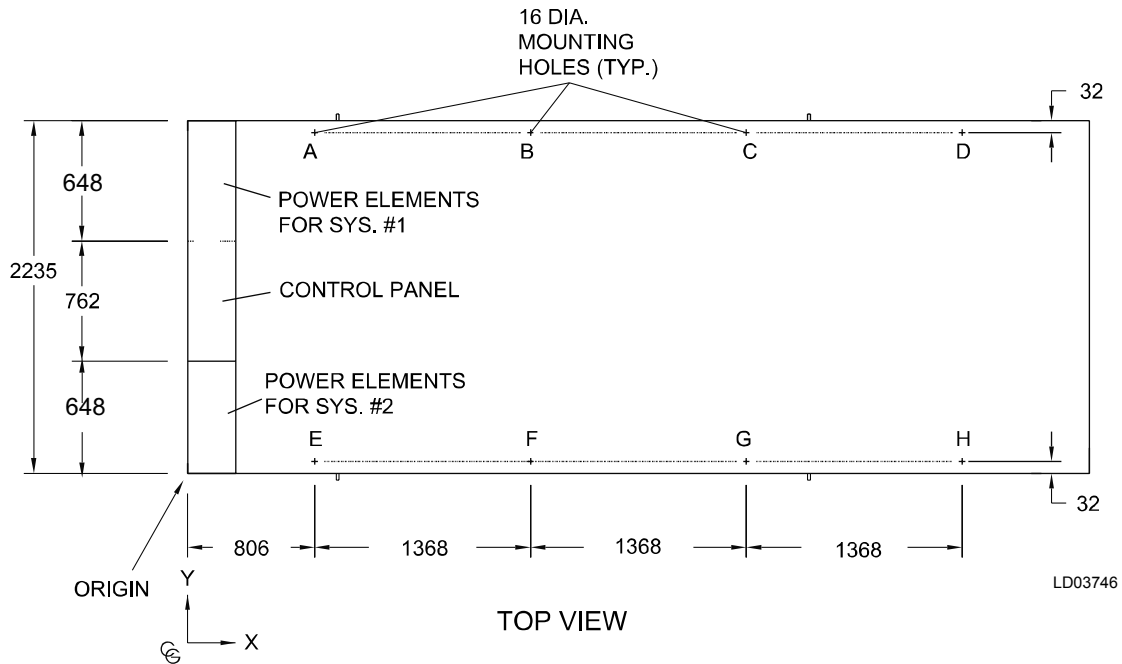

LD03746

CENTER OF GRAVITY (Alum.)

YCAS	X	Y	Z
0130	2573.0	1127.8	960.1
0140	2573.0	1127.8	960.1
0150	2710.2	1087.1	919.5
0160	2717.8	1092.2	919.5
0170	2717.8	1092.2	919.5
0180	2717.8	1092.2	919.5

CENTER OF GRAVITY (Copper)

YCAS	X	Y	Z
0130	2628.9	1127.8	1033.8
0140	2628.9	1127.8	1033.8
0150	2748.3	1092.2	995.7
0160	2573.4	1094.7	993.1
0170	2573.4	1094.7	993.1
0180	2573.4	1094.7	993.1

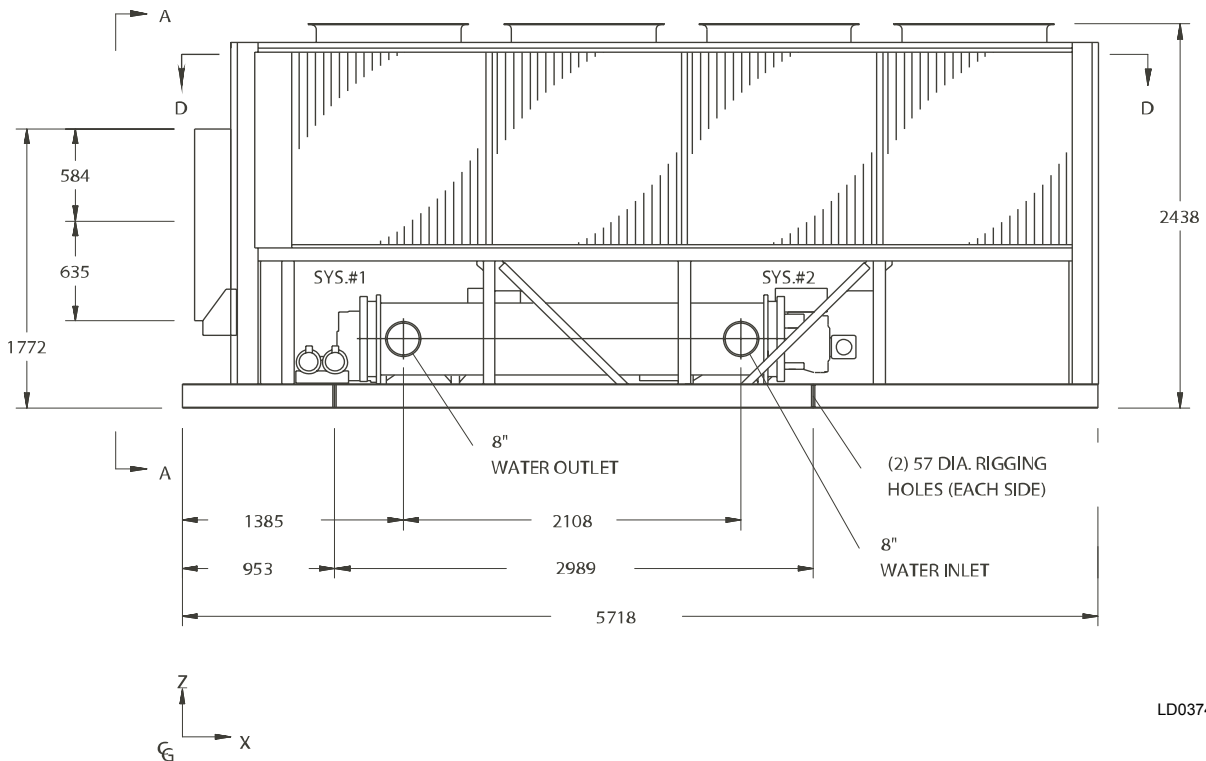

LD03747

Dimensions – YCAS0200 - 0230 (English)

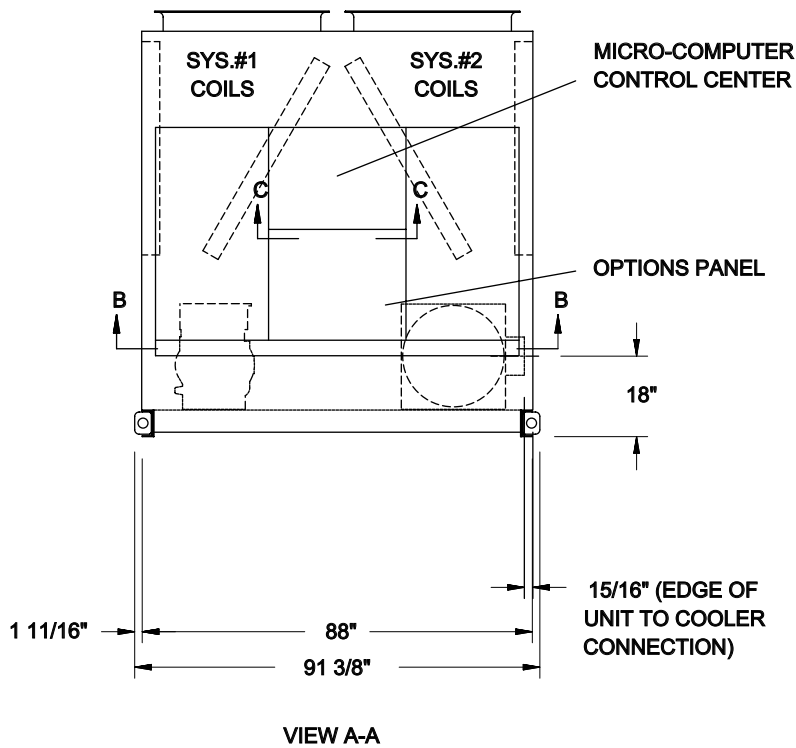
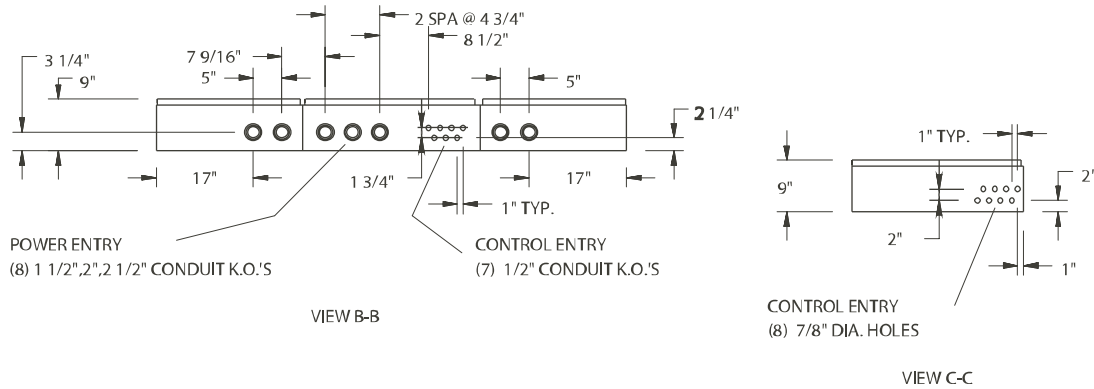

LD03748a

LD03748

NOTES:

1. Placement on a level surface free of obstructions (including snow, for winter operation) or air recirculation ensures rated performance, reliable operation and ease of maintenance. Site restrictions may compromise minimum clearances indicated below, resulting in unpredictable air flow patterns and possible diminished performance. YORK's unit controls will optimize operation without nuisance high pressure safety cutout; however, the system designer must consider potential performance degradation. Access to the unit control center assumes the unit is no higher than on spring isolators. Recommended minimum clearances: Side to wall - 6'; rear to wall - 6'; control panel end to wall - 4'; top - no obstructions allowed; distance between adjacent units - 10'. No more than one adjacent wall may be higher than the unit.

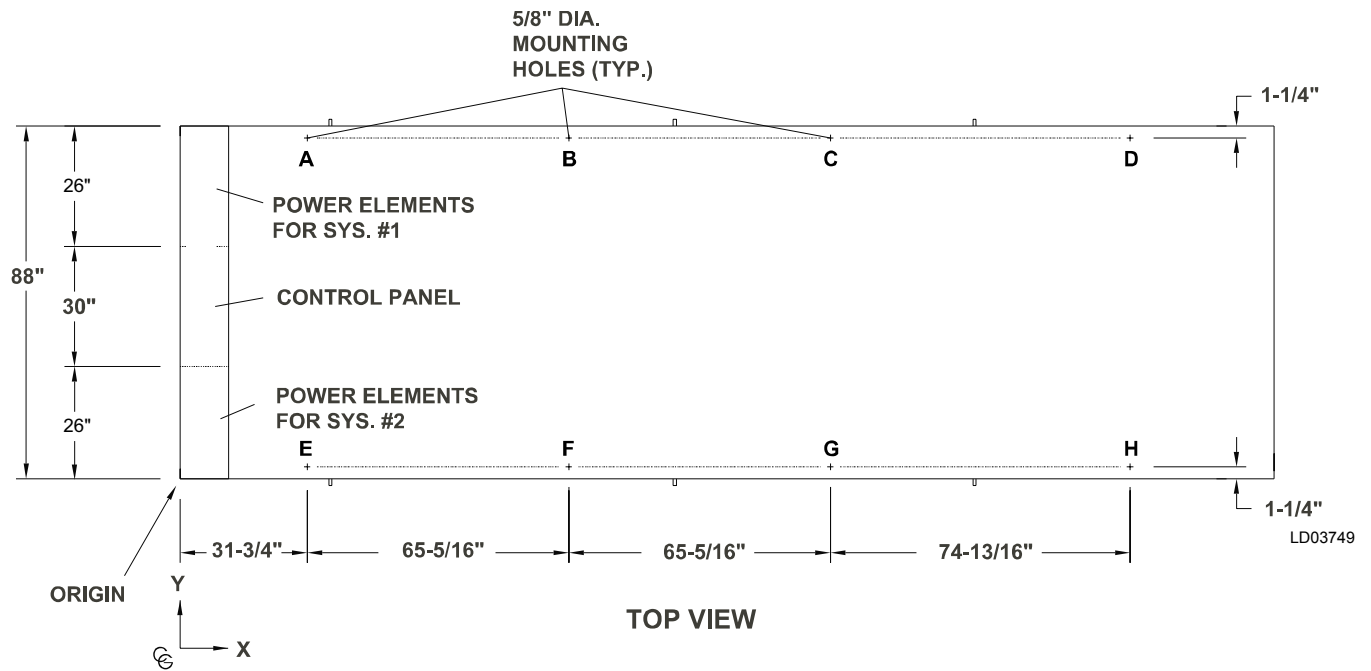

CENTER OF GRAVITY (Alum.)

YCAS	X	Y	Z
0200	119.4"	43.2"	38.0"
0210	119.4"	43.2"	38.0"
0230	119.4"	43.2"	38.0"

CENTER OF GRAVITY (Copper)

YCAS	X	Y	Z
0200	122.3"	43.3"	41.0"
0210	122.3"	43.3"	41.0"
0230	122.3"	43.3"	41.0"

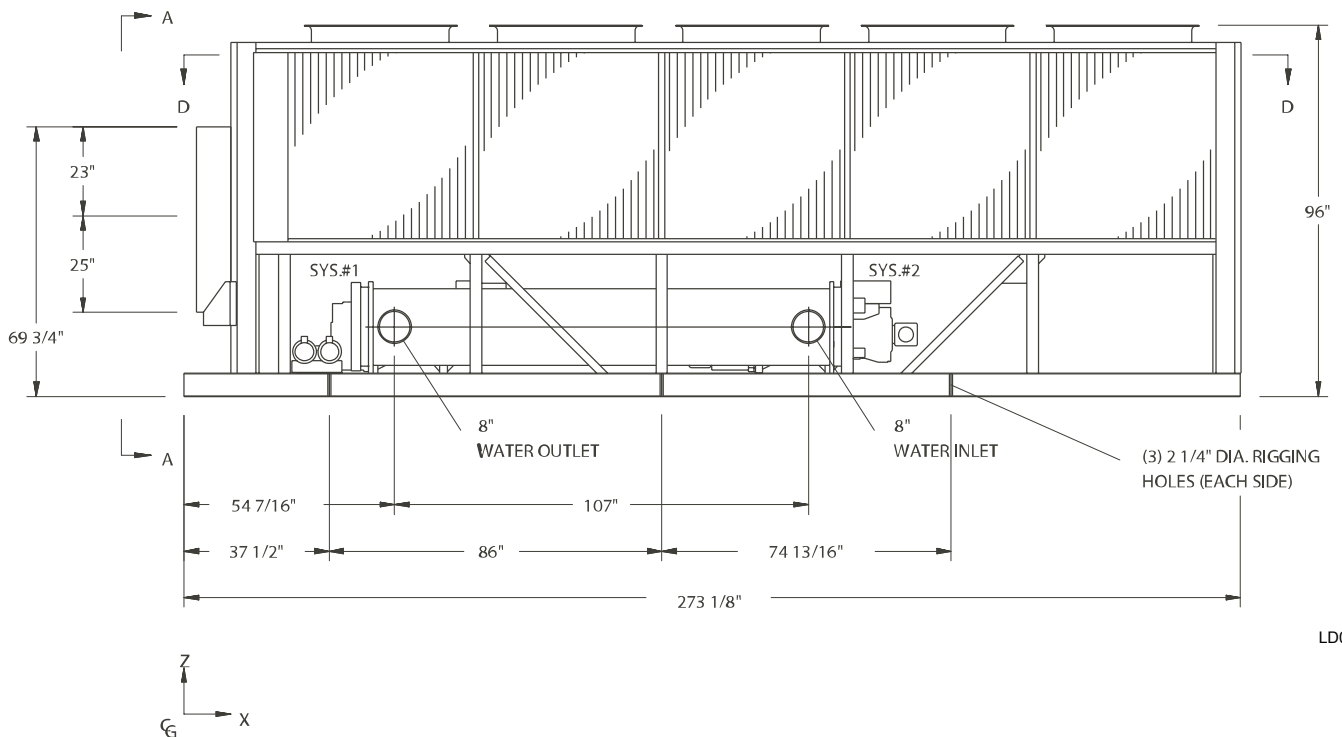

Dimensions – YCAS0200 - 0230 (SI)

All dimensions are in mm unless otherwise noted.

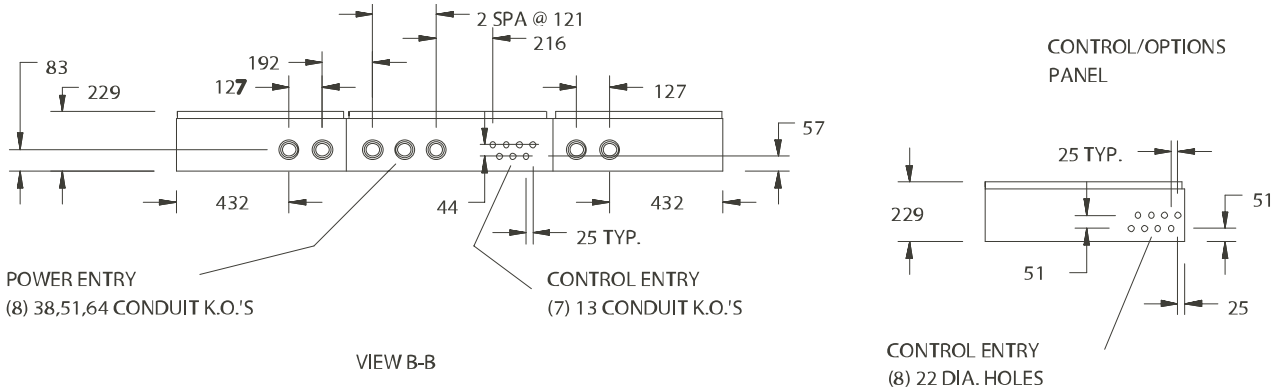

LD03751a

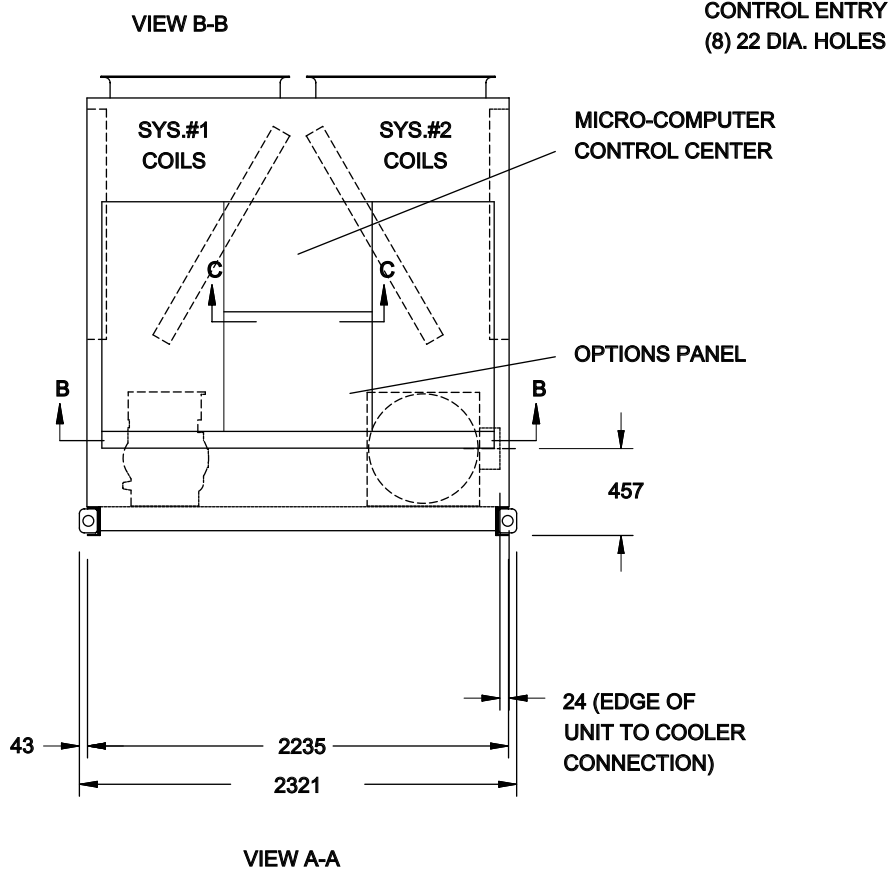

LD03751

NOTES:

1. Placement on a level surface free of obstructions (including snow, for winter operation) or air recirculation ensures rated performance, reliable operation and ease of maintenance. Site restrictions may compromise minimum clearances indicated below, resulting in unpredictable air flow patterns and possible diminished performance. YORK's unit controls will optimize operation without nuisance high pressure safety cutout; however, the system designer must consider potential performance degradation. Access to the unit control center assumes the unit is no higher than on spring isolators. Recommended minimum clearances: Side to wall - 2m; rear to wall - 2m; control panel end to wall - 1.2m; top - no obstructions allowed; distance between adjacent units - 3m. No more than one adjacent wall may be higher than the unit.

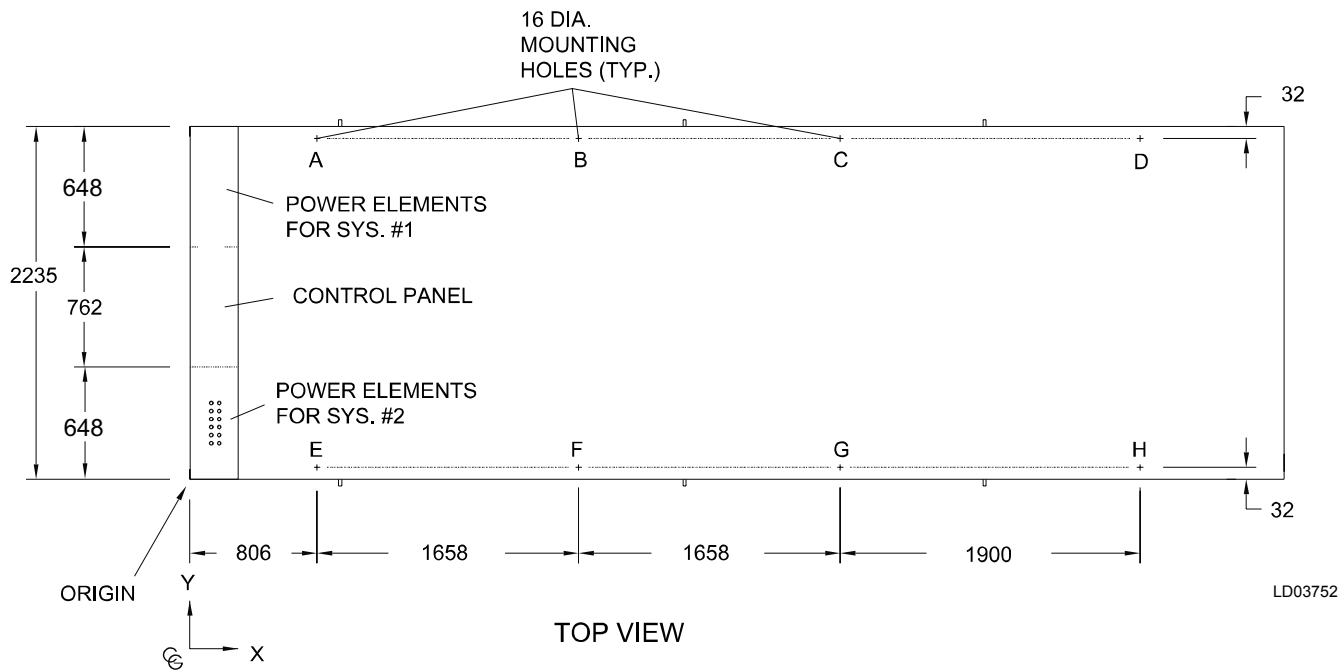

CENTER OF GRAVITY (Alum.)

YCAS	X	Y	Z
0200	3032.8	1097.3	965.2
0210	3032.8	1097.3	965.2
0230	3032.8	1097.3	965.2

CENTER OF GRAVITY (Copper)

YCAS	X	Y	Z
0200	3106.4	1099.8	1041.4
0210	3106.4	1099.8	1041.4
0230	3106.4	1099.8	1041.4

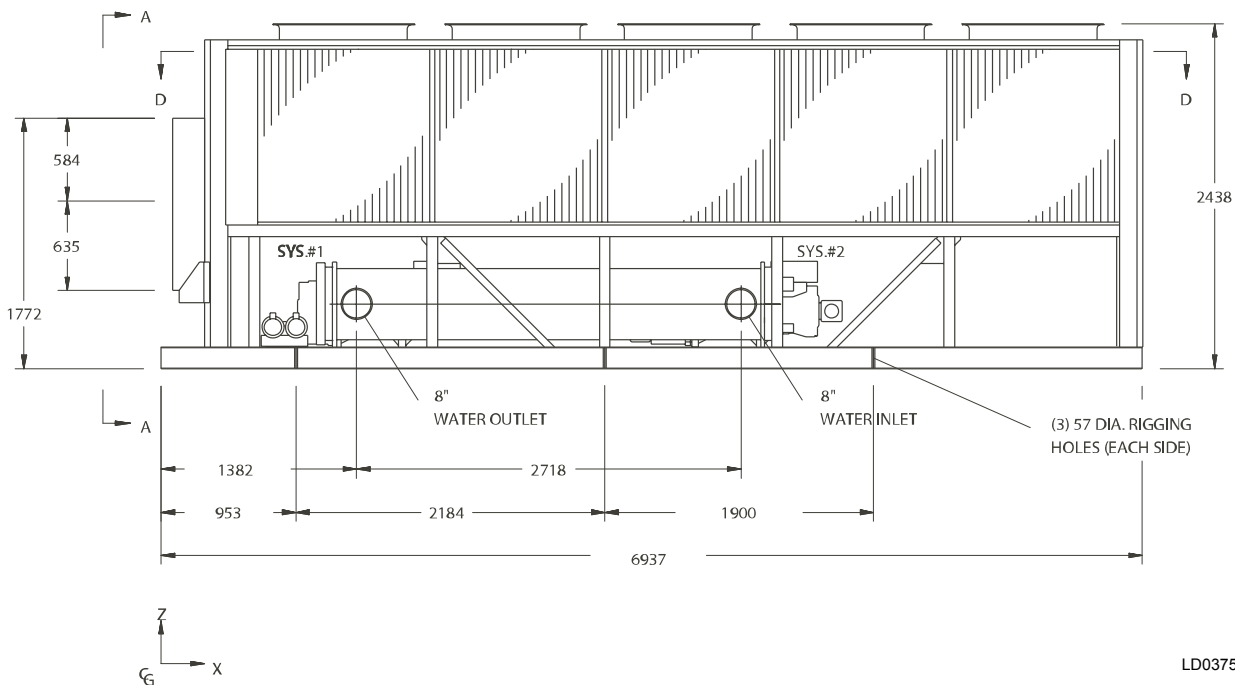

Dimensions – YCAS0250 - 0270 (English)

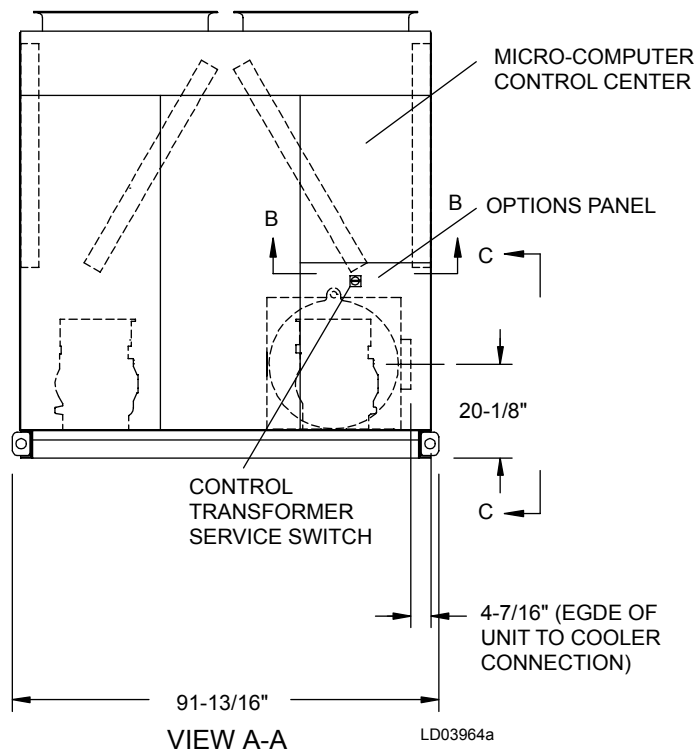
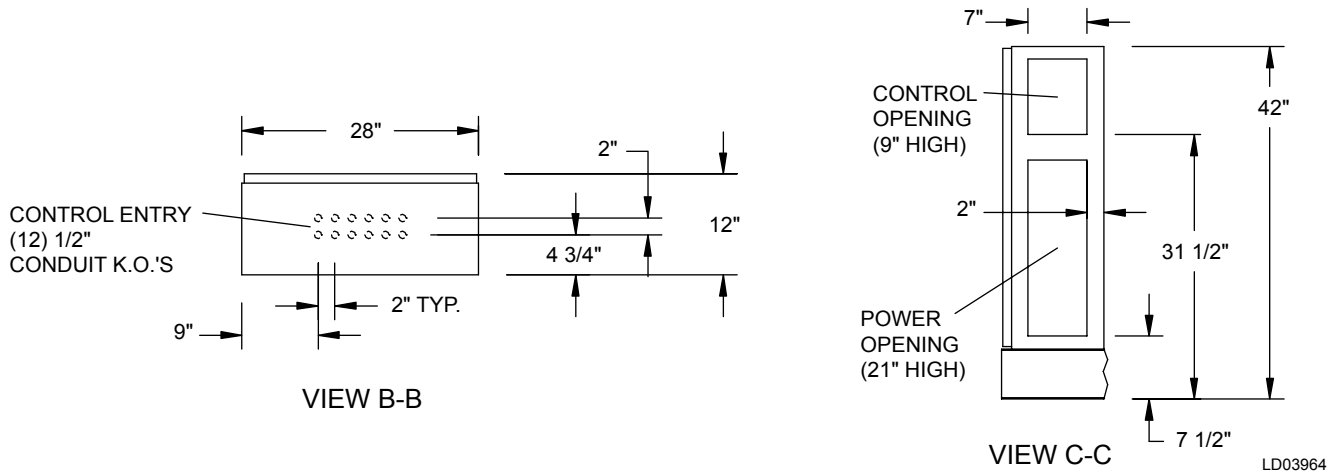

NOTES:

1. Placement on a level surface free of obstructions (including snow, for winter operation) or air recirculation ensures rated performance, reliable operation and ease of maintenance. Site restrictions may compromise minimum clearances indicated below, resulting in unpredictable air flow patterns and possible diminished performance. YORK's unit controls will optimize operation without nuisance high pressure safety cutout; however, the system designer must consider potential performance degradation. Access to the unit control center assumes the unit is no higher than on spring isolators. Recommended minimum clearances: Side to wall - 6'; rear to wall - 6'; control panel end to wall - 4'; top - no obstructions allowed; distance between adjacent units - 10'. No more than one adjacent wall may be higher than the unit.

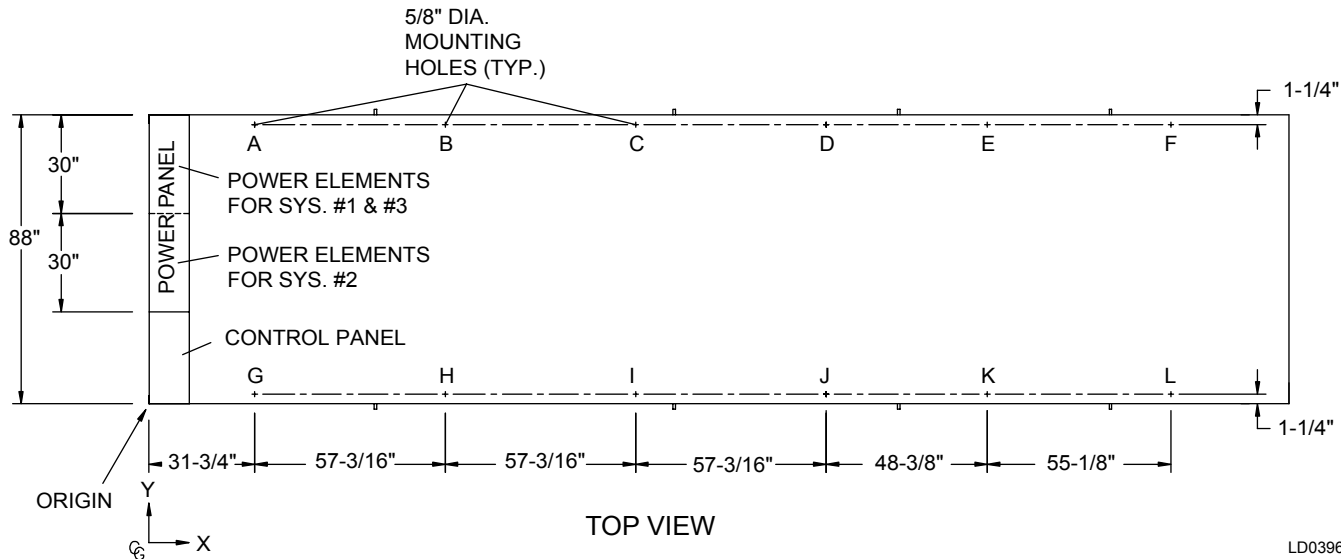

LD03965

CENTER OF GRAVITY (Alum.)				CENTER OF GRAVITY (Copper)			
YCAS	X	Y	Z	YCAS	X	Y	Z
0250	141.6"	41.6"	33.8"	0250	145.4"	41.9"	40.5"
0270	140.6"	41.7"	33.7"	0270	144.5"	42.0"	40.3"

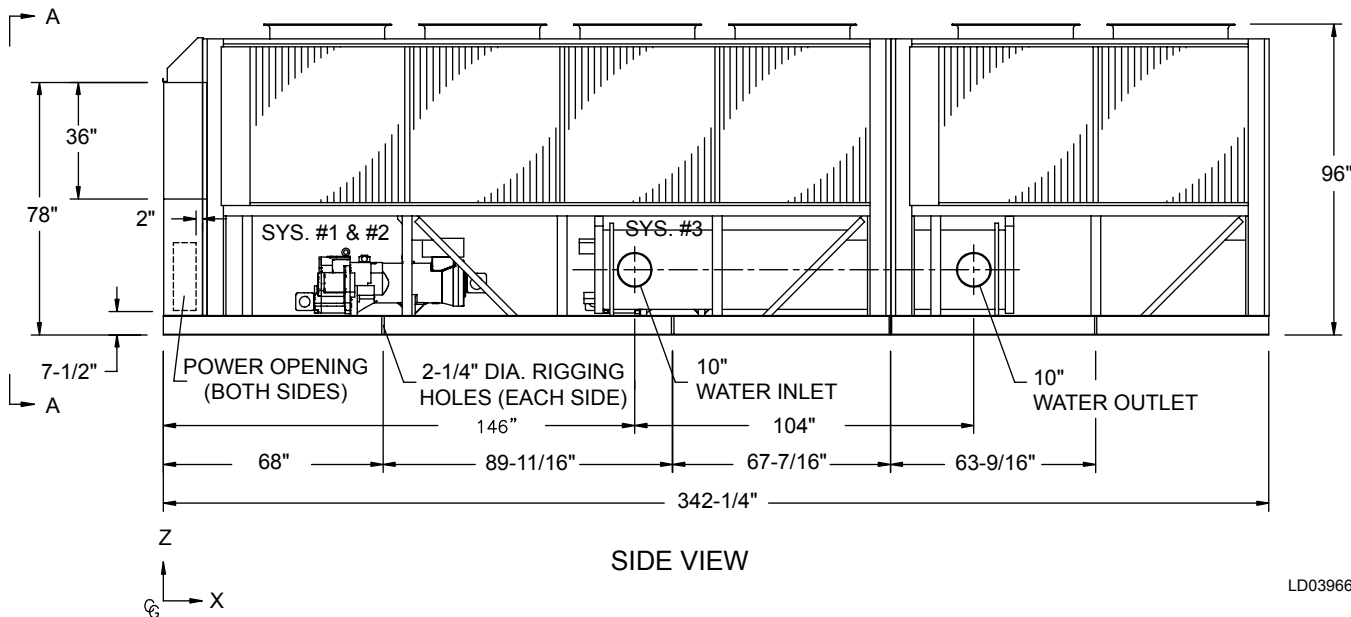

LD03966

Dimensions – YCAS0250 - 0270 (SI)

All dimensions are in mm unless otherwise noted.

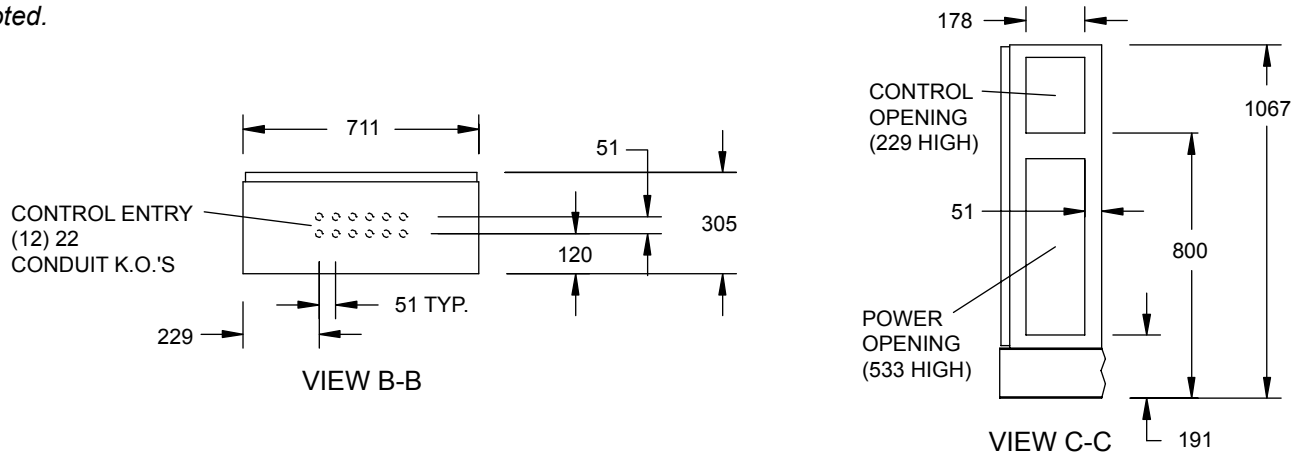

LD03968

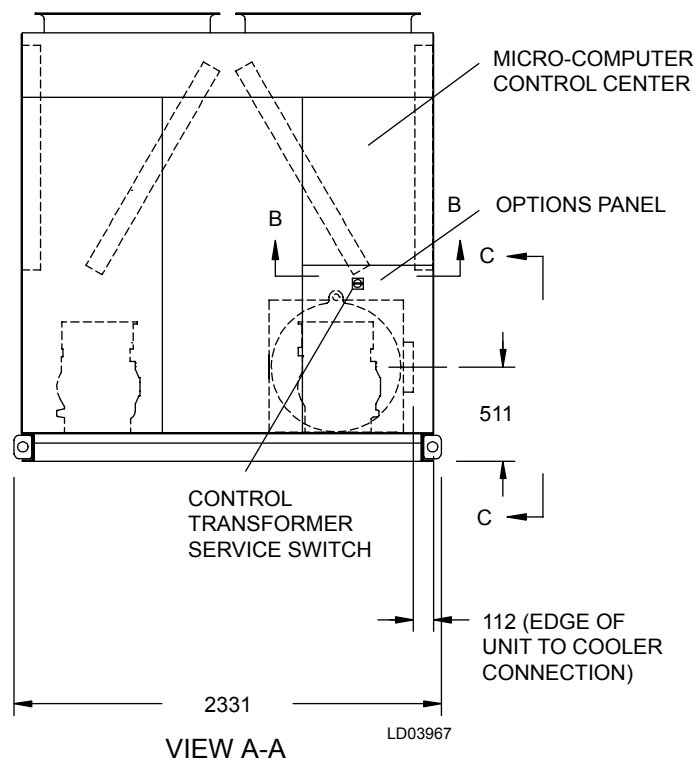

LD03967

NOTES:

1. Placement on a level surface free of obstructions (including snow, for winter operation) or air recirculation ensures rated performance, reliable operation and ease of maintenance. Site restrictions may compromise minimum clearances indicated below, resulting in unpredictable air flow patterns and possible diminished performance. YORK's unit controls will optimize operation without nuisance high pressure safety cutout; however, the system designer must consider potential performance degradation. Access to the unit control center assumes the unit is no higher than on spring isolators. Recommended minimum clearances: Side to wall - 2m; rear to wall - 2m; control panel end to wall - 1.2m; top - no obstructions allowed; distance between adjacent units - 3m. No more than one adjacent wall may be higher than the unit.

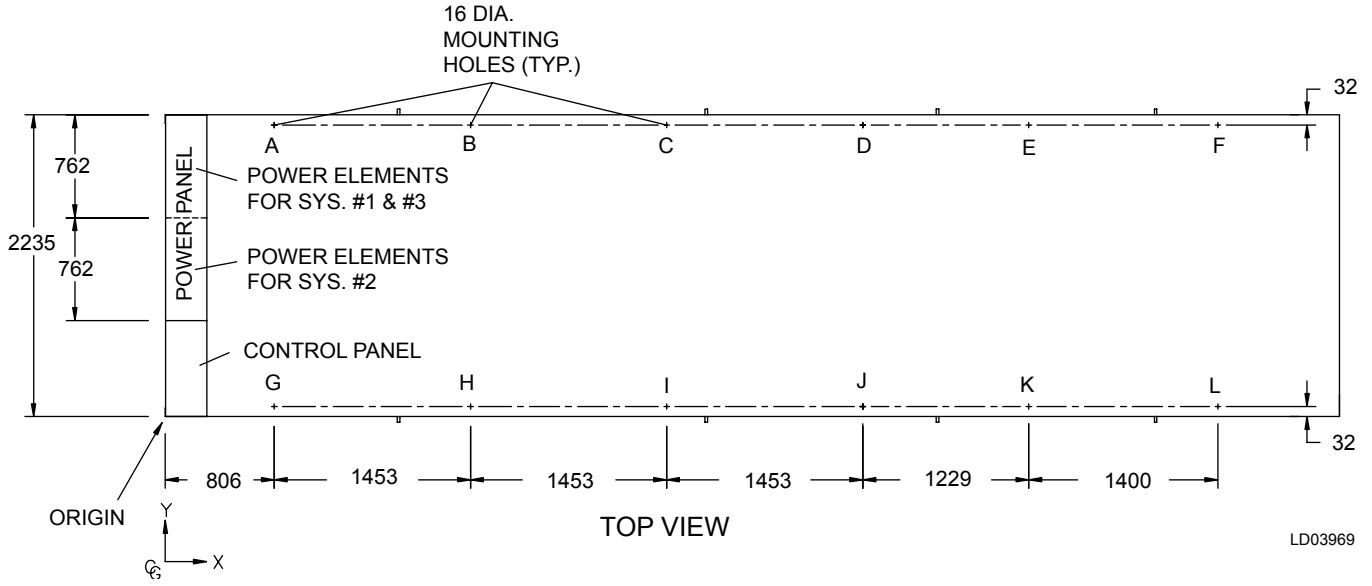

LD03969

CENTER OF GRAVITY (Alum.)			
YCAS	X	Y	Z
0250	3597	1057	860
0270	3572	1060	855

CENTER OF GRAVITY (Copper)			
YCAS	X	Y	Z
0250	3693	1063	1030
0270	3670	1066	1023

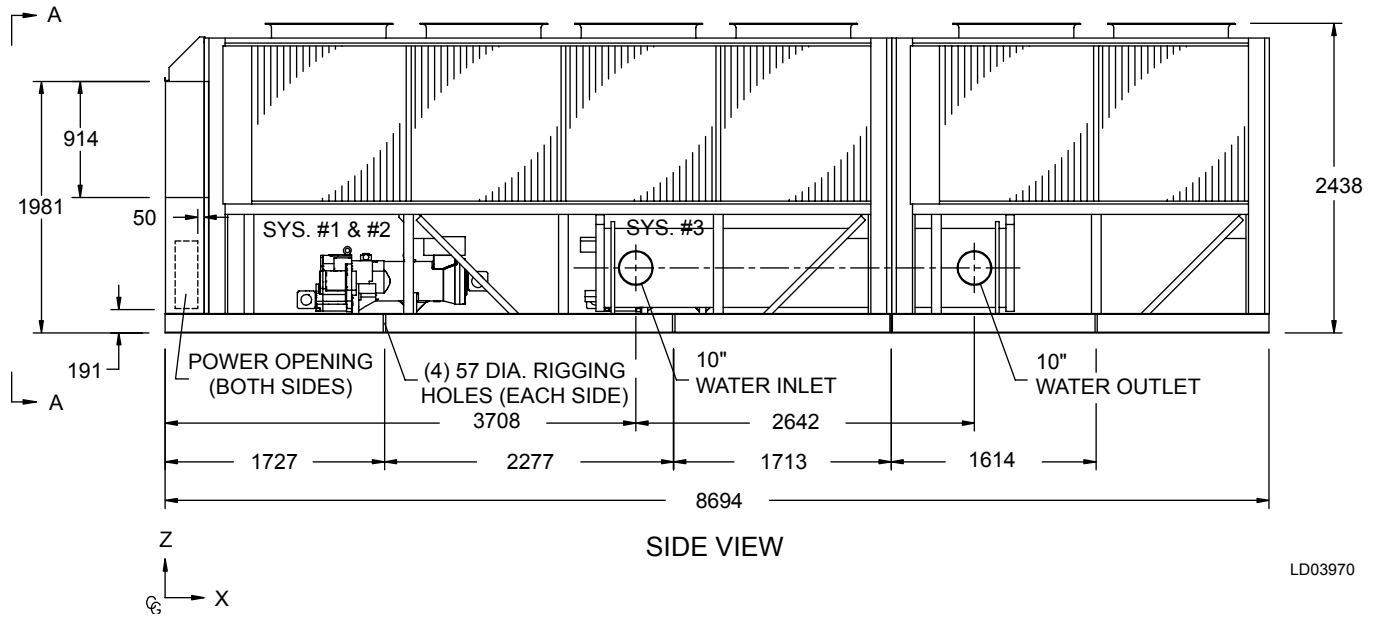

LD03970

Dimensions – YCAS0300 - 0330 (English)

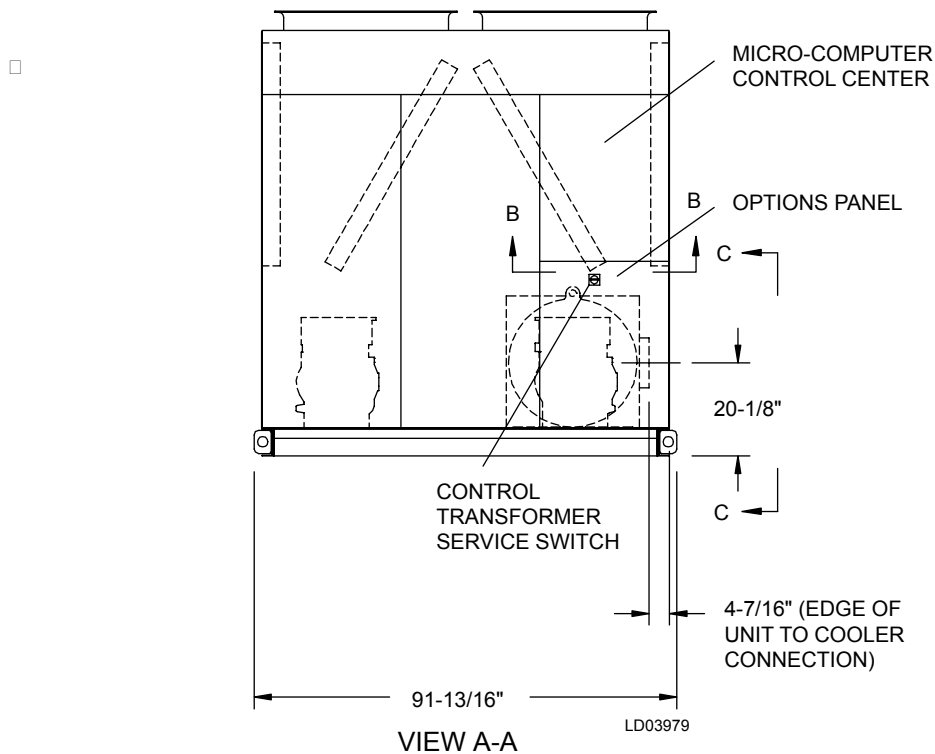
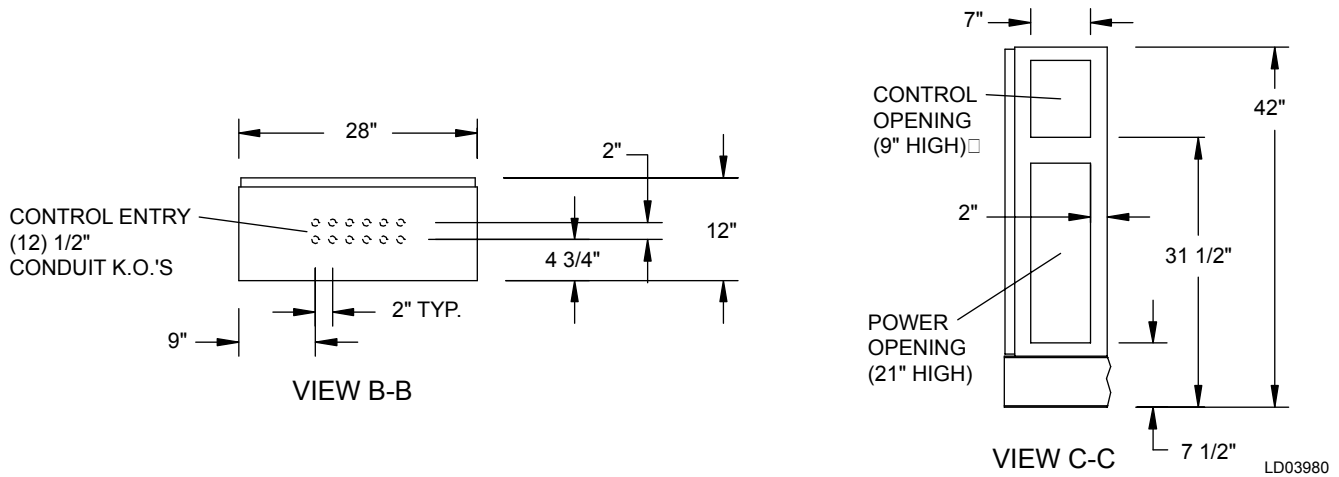

NOTES:

1. Placement on a level surface free of obstructions (including snow, for winter operation) or air recirculation ensures rated performance, reliable operation and ease of maintenance. Site restrictions may compromise minimum clearances indicated below, resulting in unpredictable air flow patterns and possible diminished performance. YORK's unit controls will optimize operation without nuisance high pressure safety cutout; however, the system designer must consider potential performance degradation. Access to the unit control center assumes the unit is no higher than on spring isolators. Recommended minimum clearances: Side to wall - 6'; rear to wall - 6'; control panel end to wall - 4'; top - no obstructions allowed; distance between adjacent units - 10'. No more than one adjacent wall may be higher than the unit.

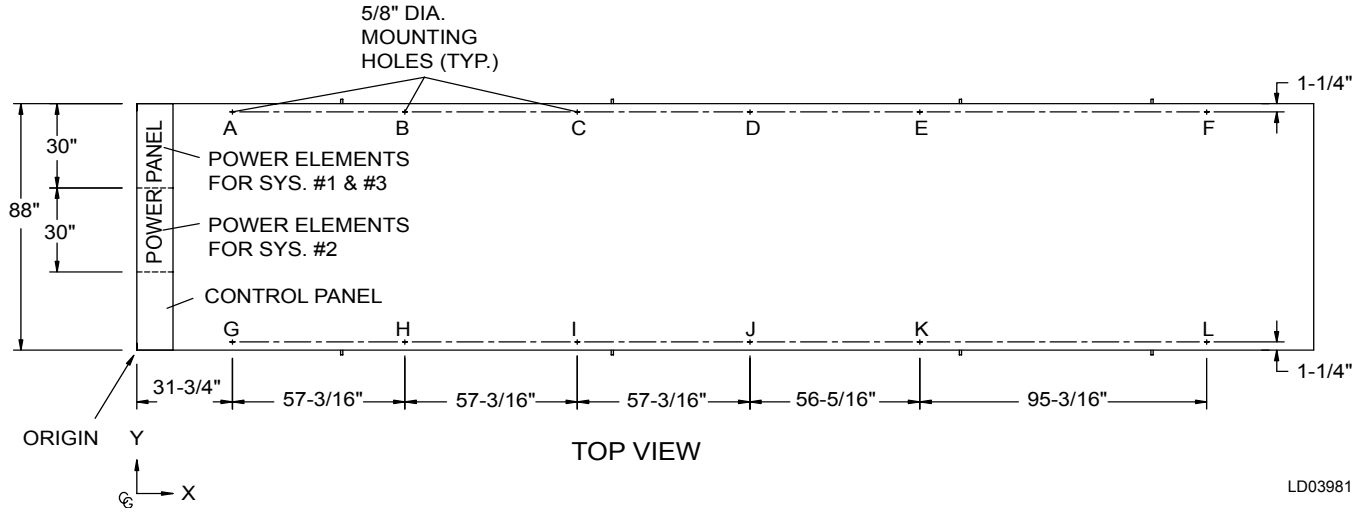

LD03981

CENTER OF GRAVITY (Alum.)

YCAS	X	Y	Z
0300	154.0"	41.6"	
34.8"			

CENTER OF GRAVITY (Copper)

YCAS	X	Y	Z
0300	159.2"	41.9"	
41.8"			

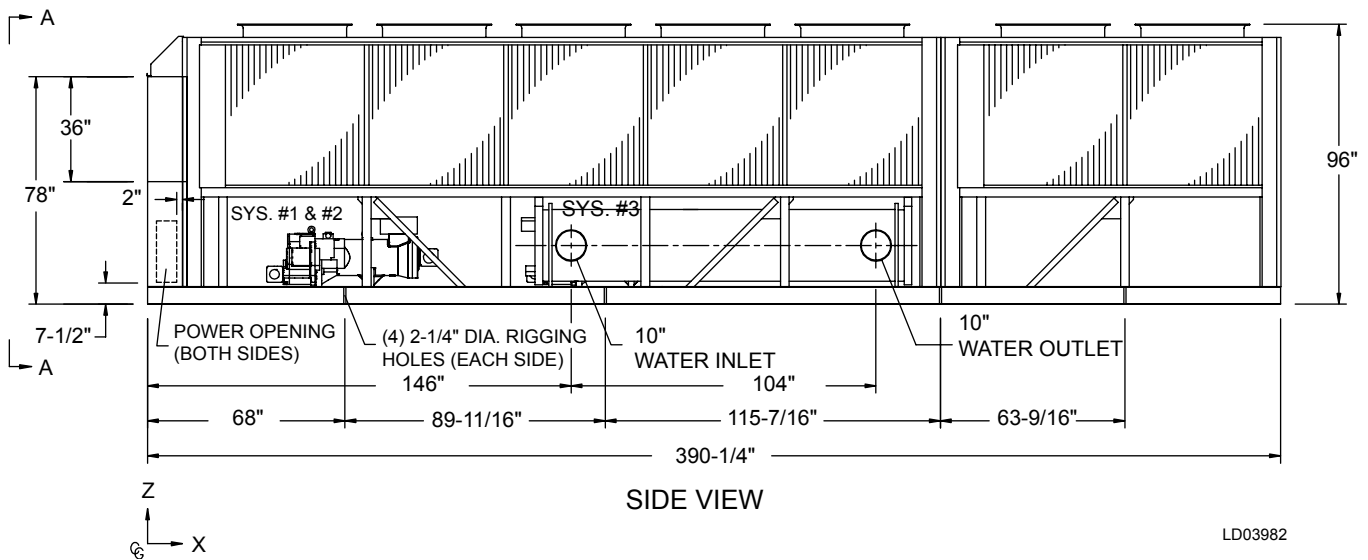

LD03982

Dimensions – YCAS0300 - 0330 (SI)

All dimensions are in mm unless otherwise noted.

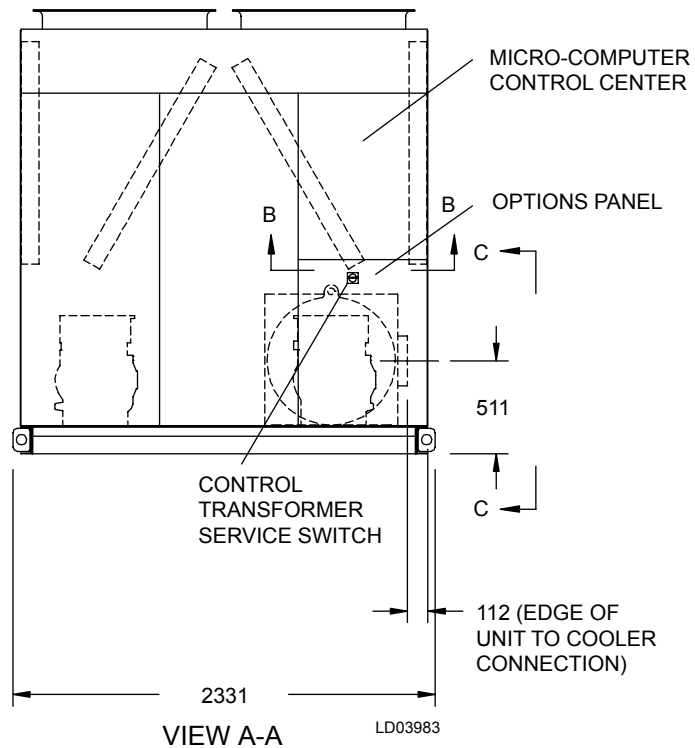
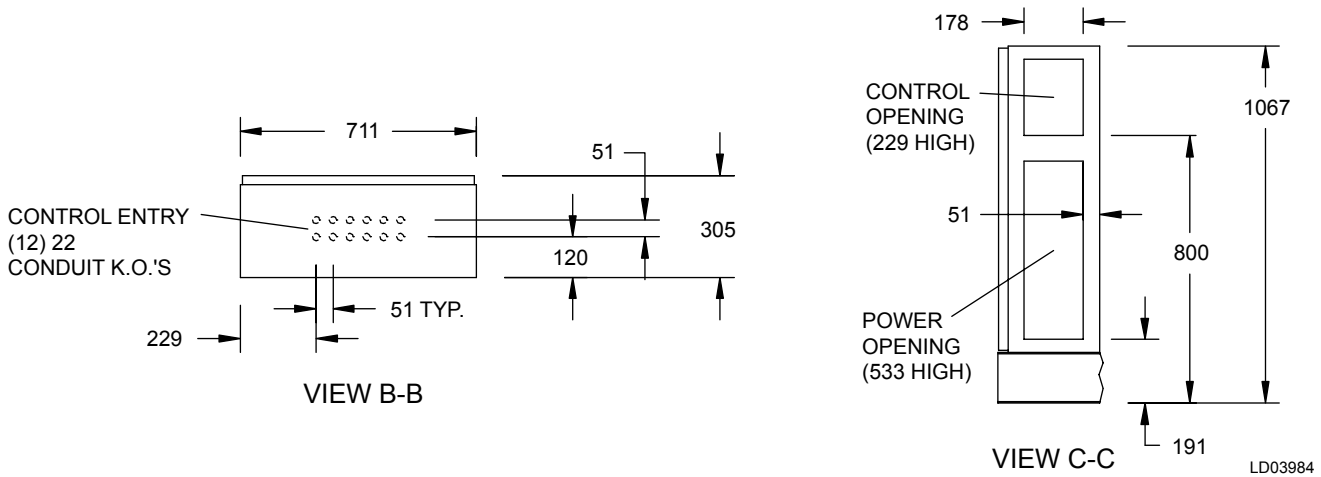

NOTES:

1. Placement on a level surface free of obstructions (including snow, for winter operation) or air recirculation ensures rated performance, reliable operation and ease of maintenance. Site restrictions may compromise minimum clearances indicated below, resulting in unpredictable air flow patterns and possible diminished performance. YORK's unit controls will optimize operation without nuisance high pressure safety cutout; however, the system designer must consider potential performance degradation. Access to the unit control center assumes the unit is no higher than on spring isolators. Recommended minimum clearances: Side to wall - 2m; rear to wall - 2m; control panel end to wall - 1.2m; top - no obstructions allowed; distance between adjacent units - 3m. No more than one adjacent wall may be higher than the unit.

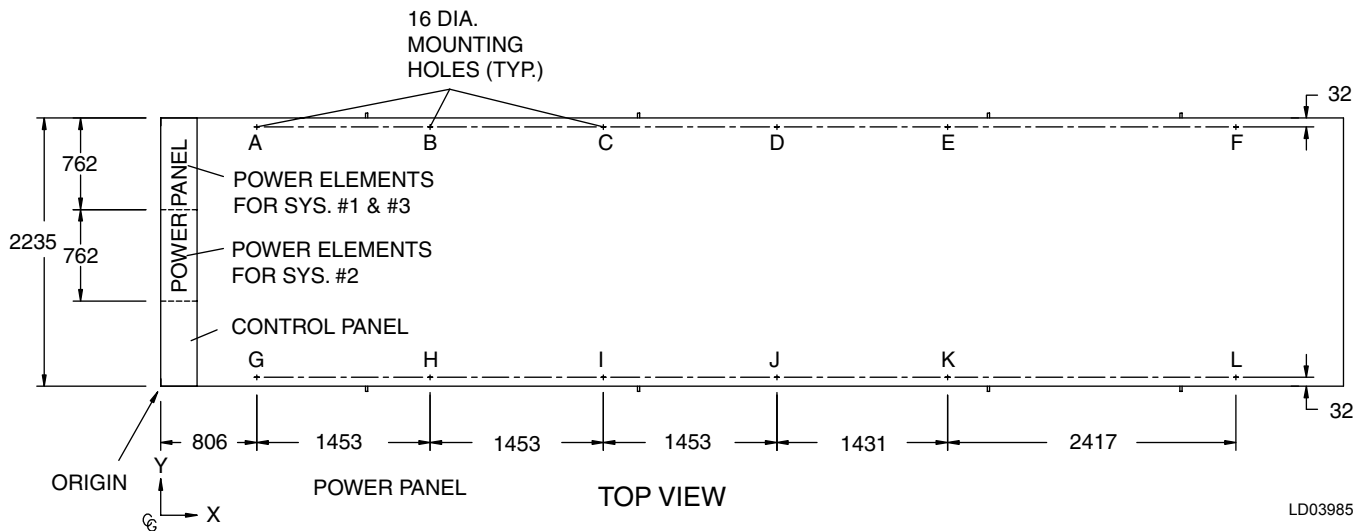

CENTER OF GRAVITY (Alum.)			
YCAS	X	Y	Z
0300	3911	1057	883
0330	3842	1058	876

CENTER OF GRAVITY (Copper)			
YCAS	X	Y	Z
0300	4045	1064	1061
0330	3982	1065	1051

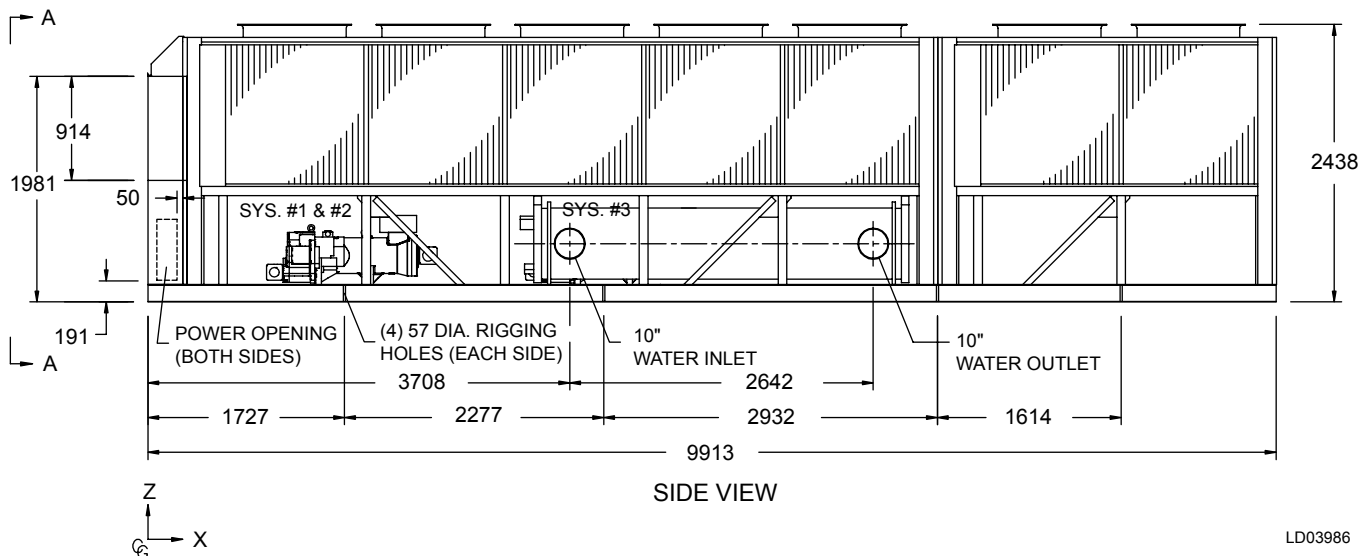

Dimensions – YCAS0360 (English)

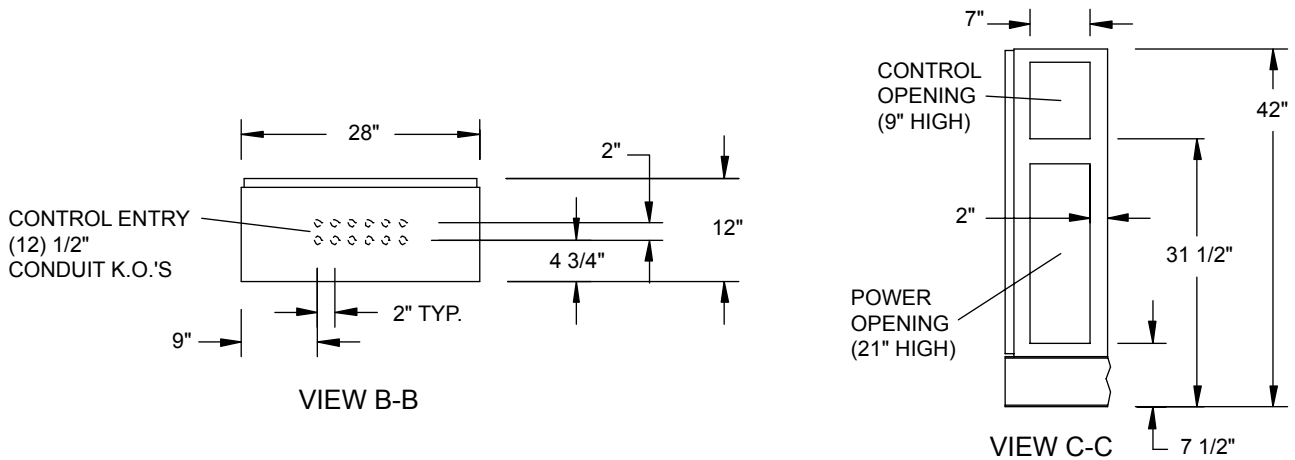

LD03996

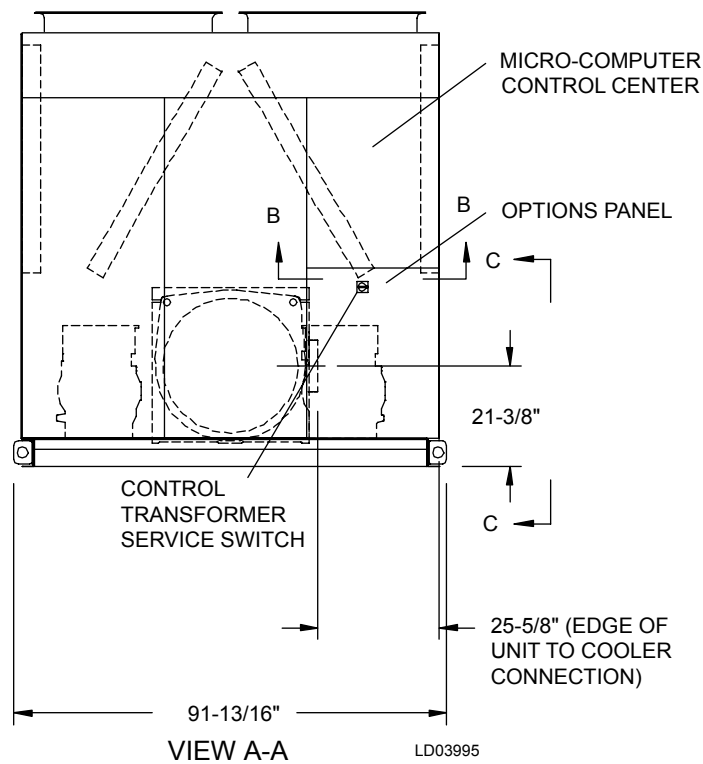

NOTES:

1. Placement on a level surface free of obstructions (including snow, for winter operation) or air recirculation ensures rated performance, reliable operation and ease of maintenance. Site restrictions may compromise minimum clearances indicated below, resulting in unpredictable air flow patterns and possible diminished performance. YORK's unit controls will optimize operation without nuisance high pressure safety cutout; however, the system designer must consider potential performance degradation. Access to the unit control center assumes the unit is no higher than on spring isolators. Recommended minimum clearances: Side to wall - 6'; rear to wall - 6'; control panel end to wall - 4'; top - no obstructions allowed; distance between adjacent units - 10'. No more than one adjacent wall may be higher than the unit.

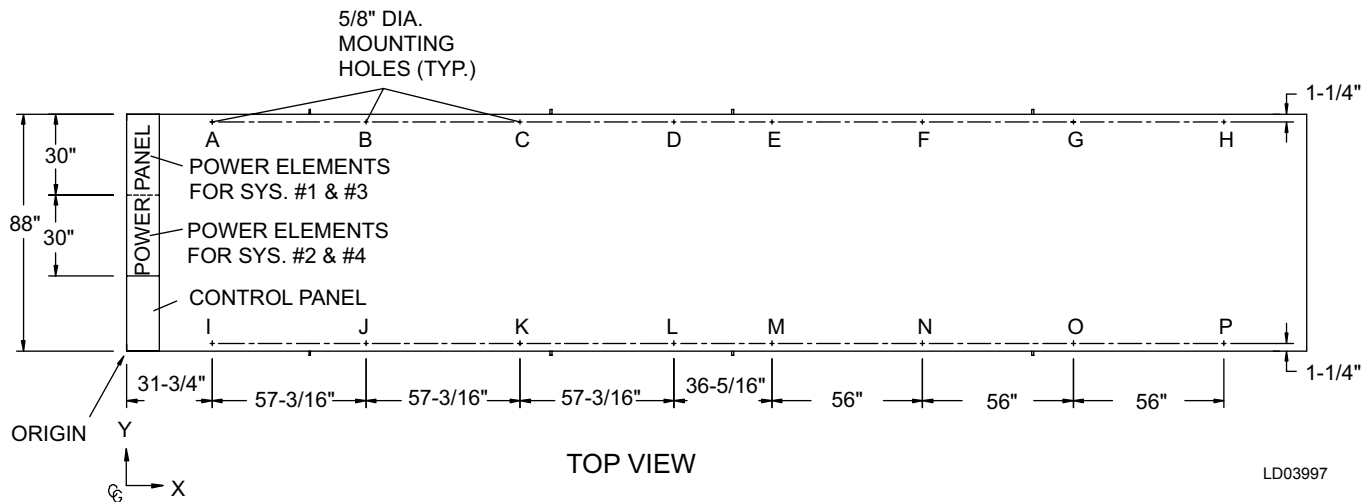

LD03997

CENTER OF GRAVITY (Alum.)

YCAS	X	Y	Z
0360	197.3"	44.0"	

CENTER OF GRAVITY (Copper)

YCAS	X	Y	Z
0360	200.7"	44.0"	

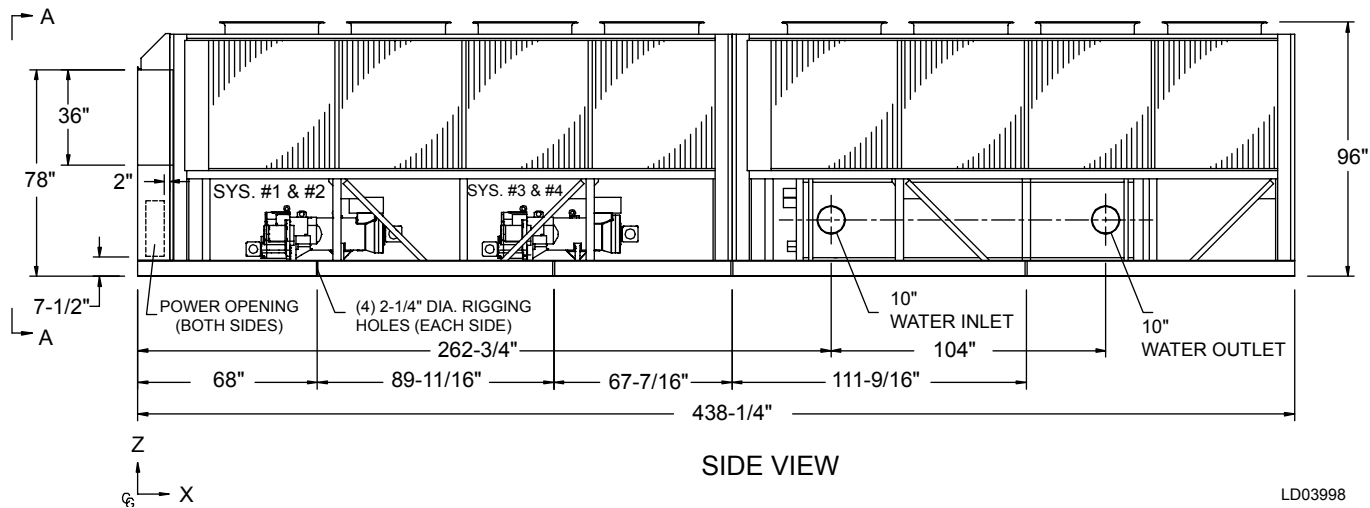

LD03998

Dimensions – YCAS0360 (SI)

All dimensions are in mm unless otherwise noted.

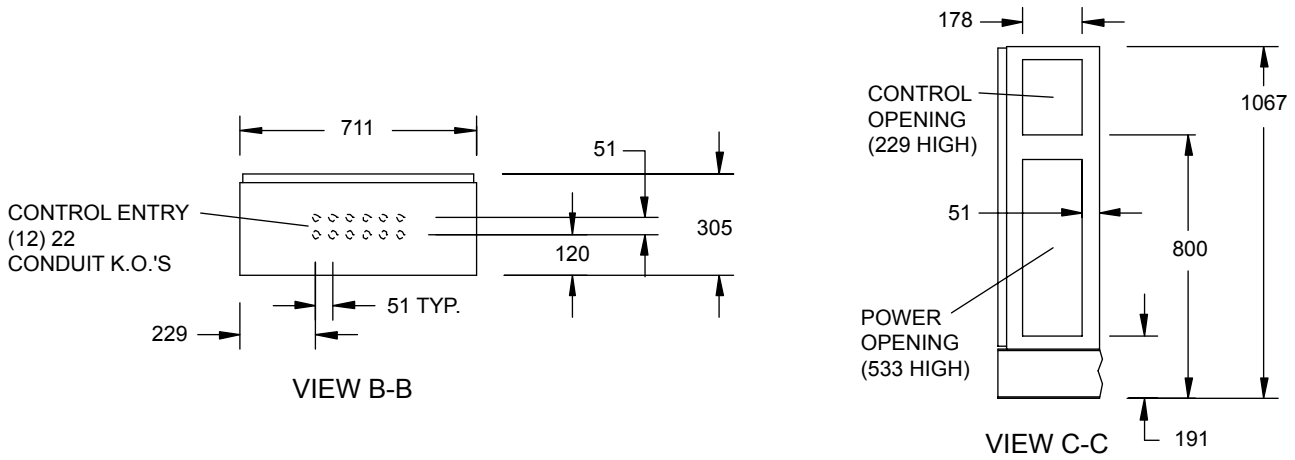

LD04000

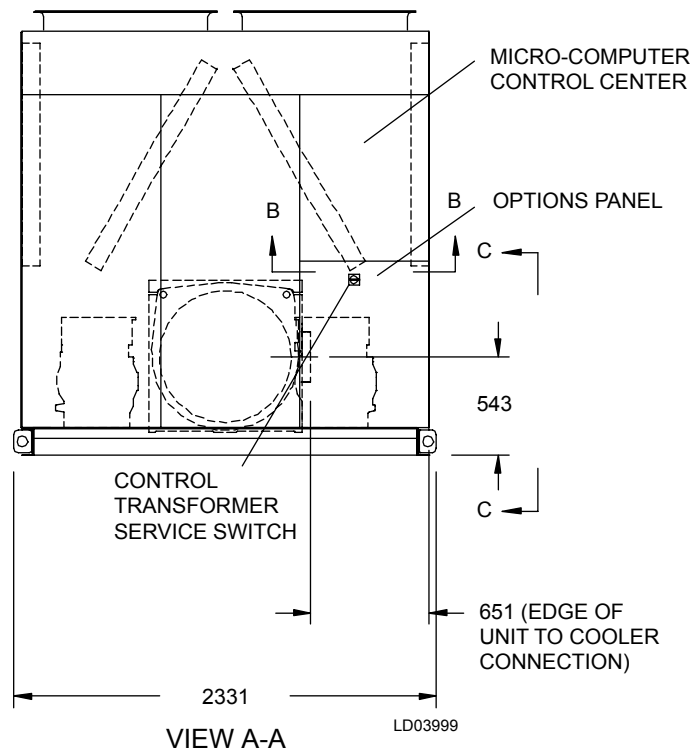

LD03999

NOTES:

1. Placement on a level surface free of obstructions (including snow, for winter operation) or air recirculation ensures rated performance, reliable operation and ease of maintenance. Site restrictions may compromise minimum clearances indicated below, resulting in unpredictable air flow patterns and possible diminished performance. YORK's unit controls will optimize operation without nuisance high pressure safety cutout; however, the system designer must consider potential performance degradation. Access to the unit control center assumes the unit is no higher than on spring isolators. Recommended minimum clearances: Side to wall - 2m; rear to wall - 2m; control panel end to wall - 1.2m; top - no obstructions allowed; distance between adjacent units - 3m. No more than one adjacent wall may be higher than the unit.

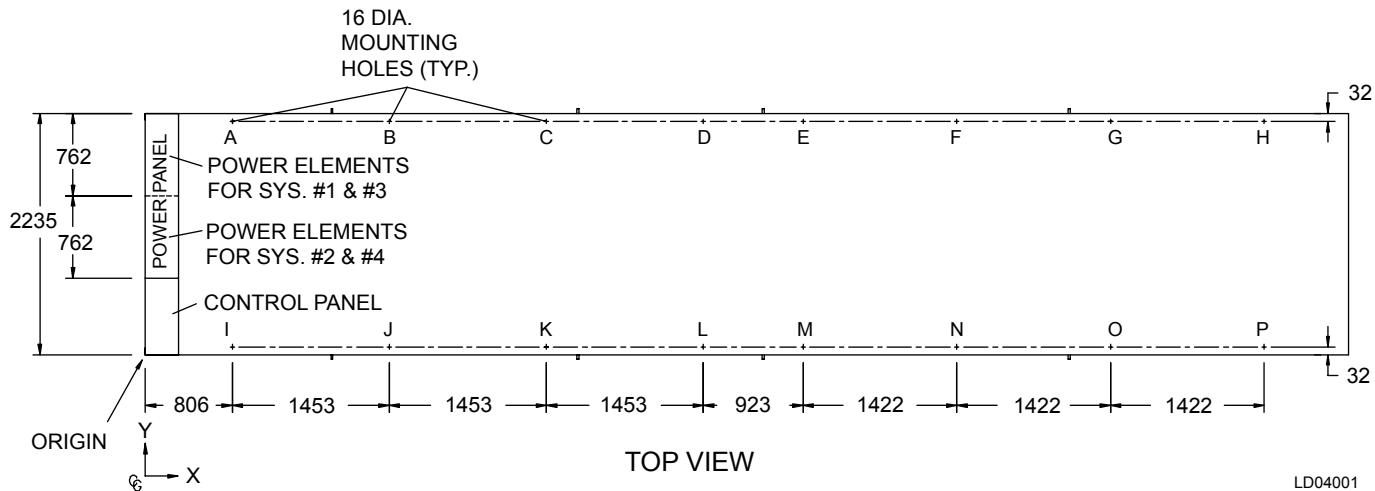

LD04001

CENTER OF GRAVITY (Alum.)

YCAS	X	Y	Z
0360	5011	1117	844

CENTER OF GRAVITY (Copper)

YCAS	X	Y	Z
0360	5097	1117	1005

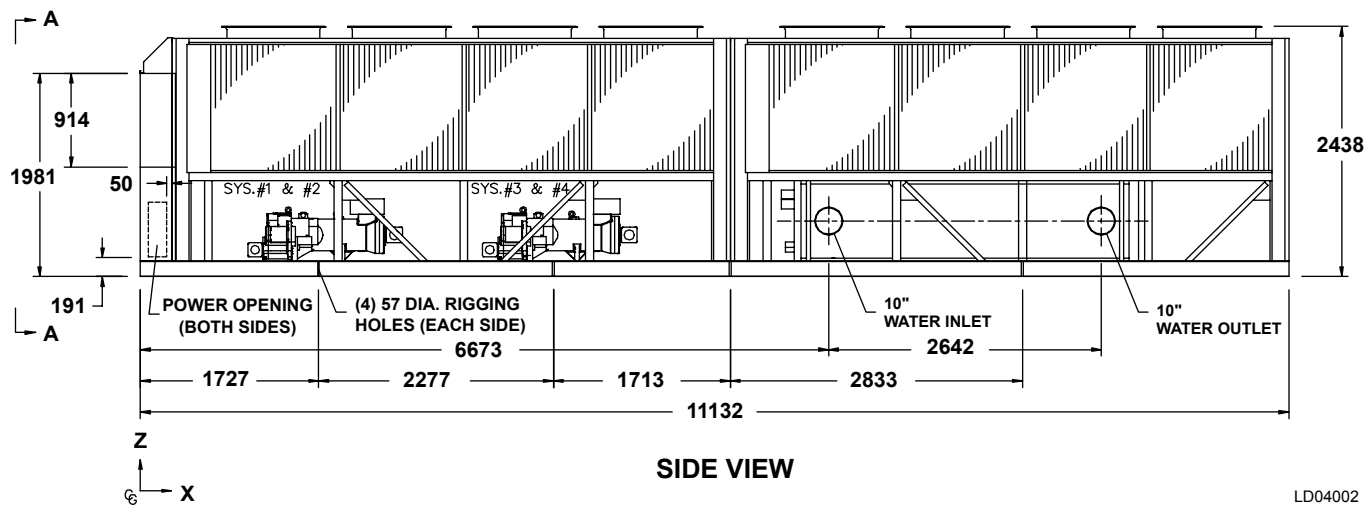

LD04002

Dimensions – YCAS0400 - 0440 (English)

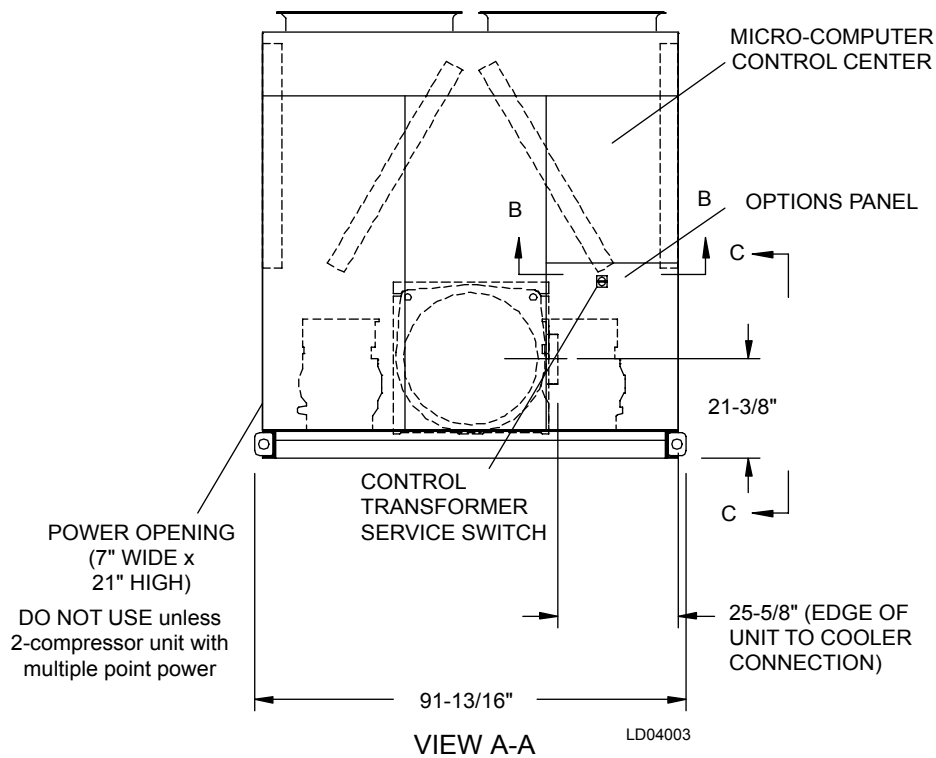
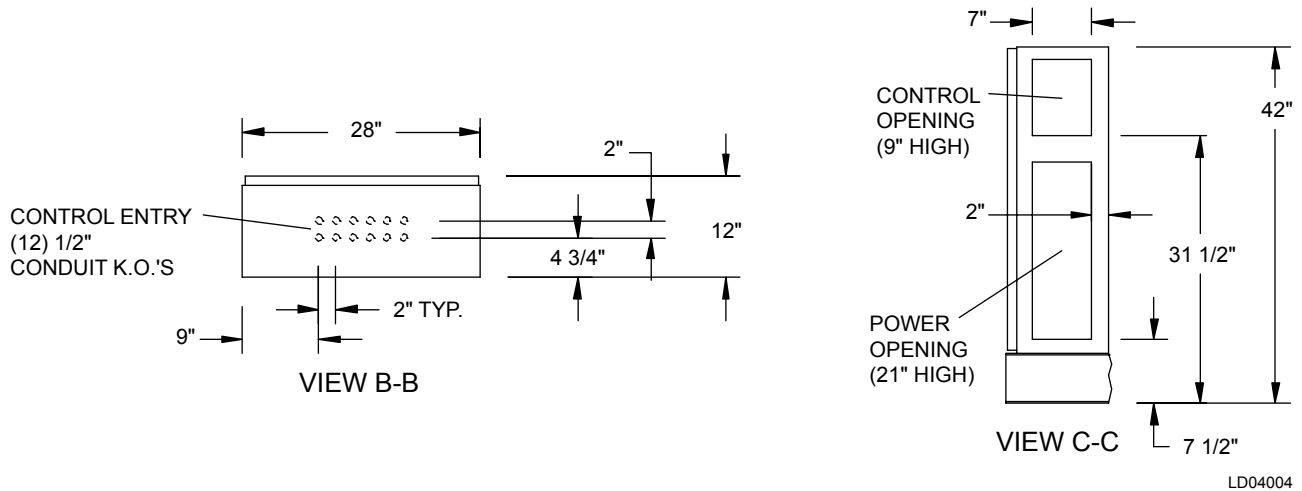

NOTES:

1. Placement on a level surface free of obstructions (including snow, for winter operation) or air recirculation ensures rated performance, reliable operation and ease of maintenance. Site restrictions may compromise minimum clearances indicated below, resulting in unpredictable air flow patterns and possible diminished performance. YORK's unit controls will optimize operation without nuisance high pressure safety cutout; however, the system designer must consider potential performance degradation. Access to the unit control center assumes the unit is no higher than on spring isolators. Recommended minimum clearances: Side to wall - 6'; rear to wall - 6'; control panel end to wall - 4'; top - no obstructions allowed; distance between adjacent units - 10'. No more than one adjacent wall may be higher than the unit.

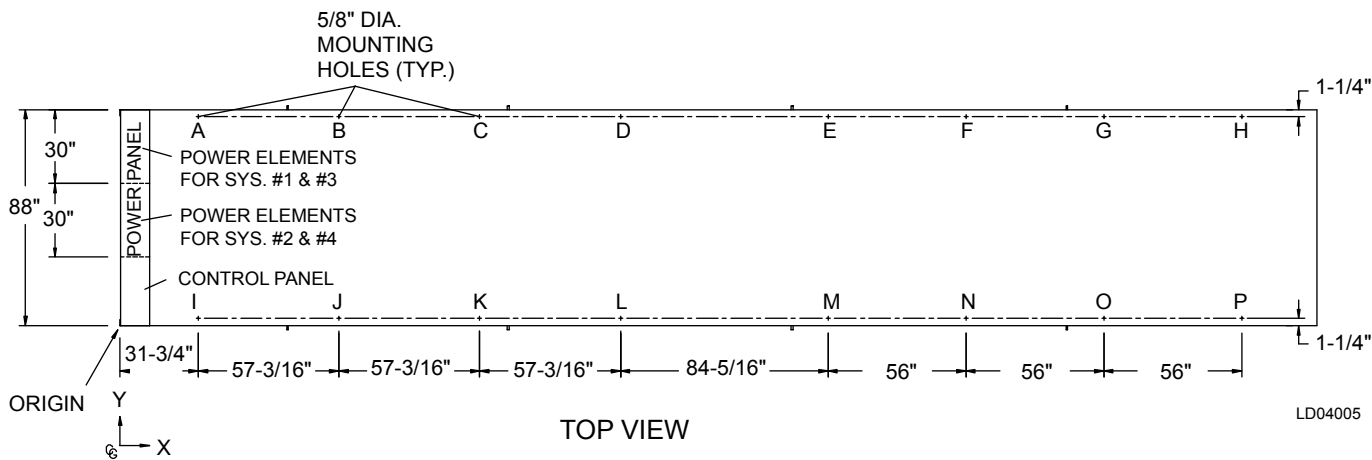

CENTER OF GRAVITY (Alum.)

YCAS	X	Y	Z
0400	218.7"	44.0"	
34.1"			

CENTER OF GRAVITY (Copper)

YCAS	X	Y	Z
0400	222.5"	44.0"	
40.8"			

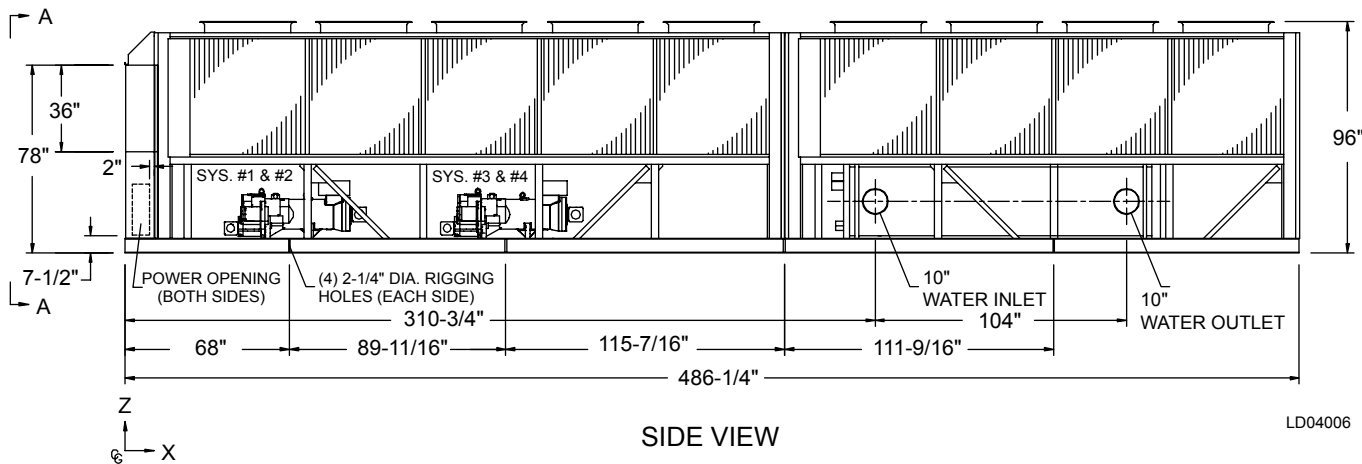

Dimensions – YCAS0400 - 0440 (SI)

All dimensions are in mm
unless otherwise noted.

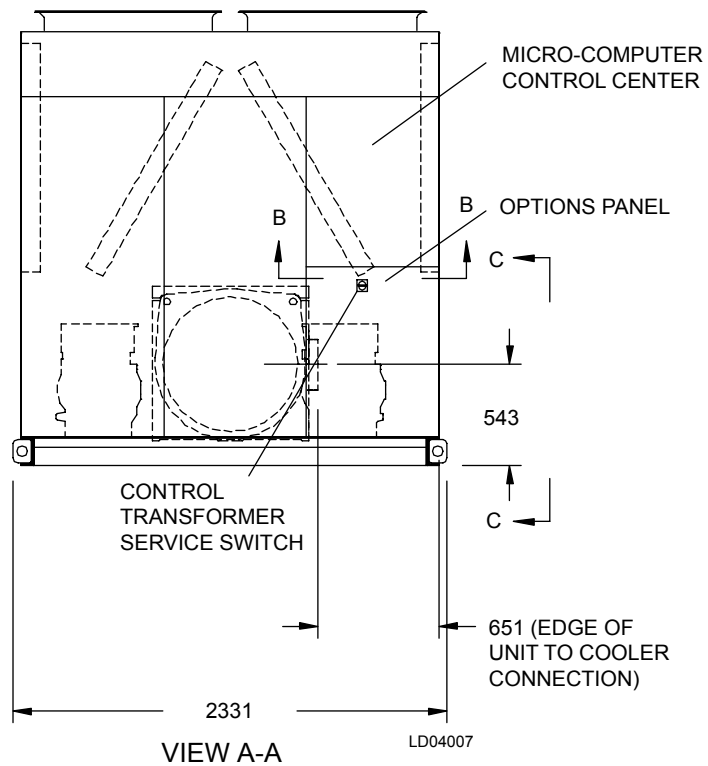
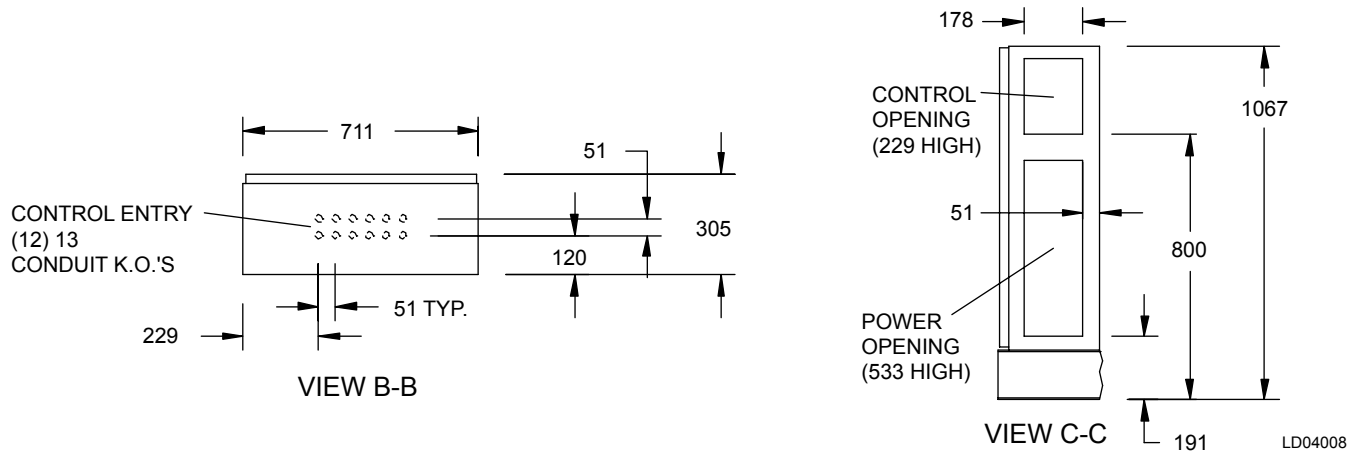

NOTES:

1. Placement on a level surface free of obstructions (including snow, for winter operation) or air recirculation ensures rated performance, reliable operation and ease of maintenance. Site restrictions may compromise minimum clearances indicated below, resulting in unpredictable air flow patterns and possible diminished performance. YORK's unit controls will optimize operation without nuisance high pressure safety cutout; however, the system designer must consider potential performance degradation. Access to the unit control center assumes the unit is no higher than on spring isolators. Recommended minimum clearances: Side to wall - 2m; rear to wall - 2m; control panel end to wall - 1.2m; top - no obstructions allowed; distance between adjacent units - 3m. No more than one adjacent wall may be higher than the unit.

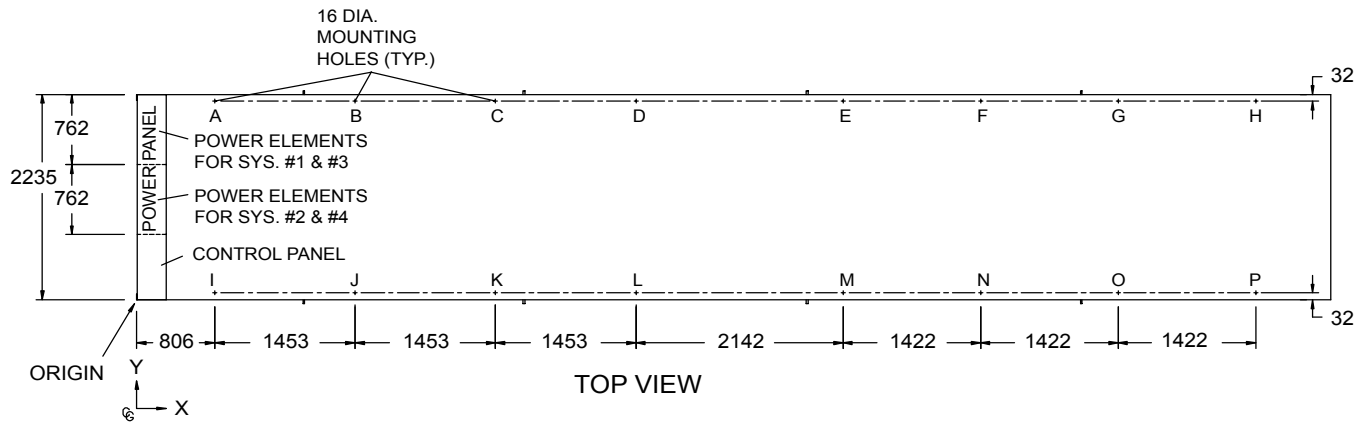

CENTER OF GRAVITY (Alum.)

YCAS	X	Y	Z
0400	5556	1117	867
0440	5459	1117	861

CENTER OF GRAVITY (Copper)

YCAS	X	Y	Z
0400	5650	1117	1037
0440	5563	1117	1028

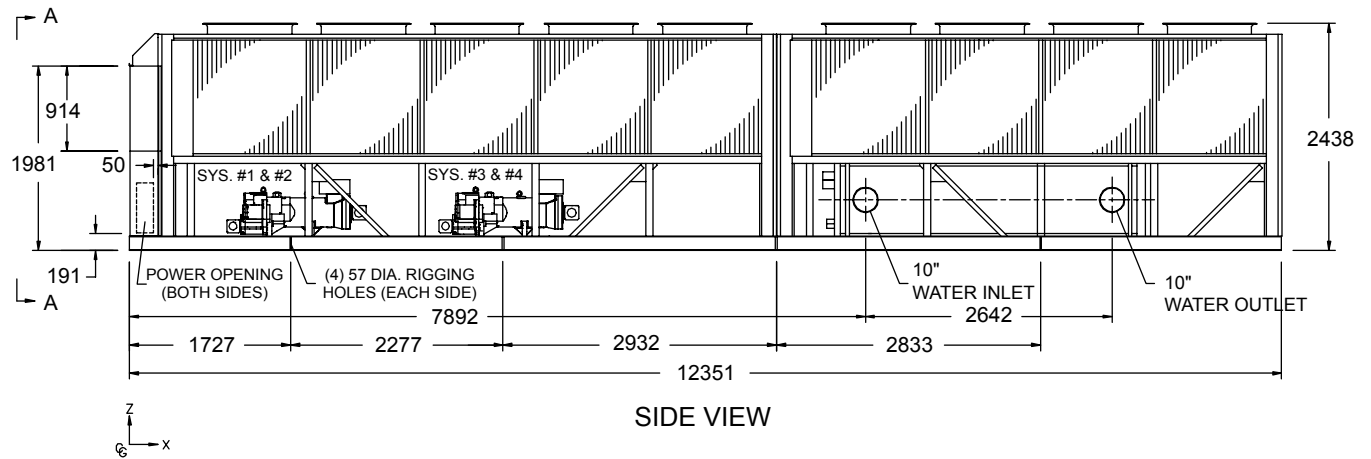

Operating Weights – Aluminum Fin Coils

ALUMINUM FIN COIL WEIGHT DISTRIBUTION BY MODEL (LBS)

YCAS	A	B	C	D	E	F	G	H	I	J	K	L	M	N	O	P	TOTAL
0130	1,550	1,339	1,657	678	1,573	1,111	1,707	700	—	—	—	—	—	—	—	—	10,315
0140	1,576	1,356	1,692	688	1,614	1,136	1,764	711	—	—	—	—	—	—	—	—	10,537
0150	1,634	1,227	1,517	1,095	1,794	1,194	1,472	1,330	—	—	—	—	—	—	—	—	11,263
0160	1,637	1,210	1,538	1,109	1,796	1,163	1,460	1,334	—	—	—	—	—	—	—	—	11,247
0170	1,639	1,231	1,554	1,114	1,798	1,198	1,485	1,339	—	—	—	—	—	—	—	—	11,358
0180	1,662	1,227	1,561	1,132	1,836	1,188	1,494	1,369	—	—	—	—	—	—	—	—	11,358
0200	1,856	1,358	2,077	869	1,983	1,207	2,261	902	—	—	—	—	—	—	—	—	12,513
0210	1,859	1,387	2,089	874	1,986	1,254	2,278	907	—	—	—	—	—	—	—	—	12,634
0230	1,862	1,415	2,098	878	1,989	1,303	2,289	911	—	—	—	—	—	—	—	—	12,745
0250	1,209	1,821	1,964	1,051	1,038	830	1,209	2,010	2,351	797	2,112	943	—	—	—	—	17,334
0270	1,225	1,837	2,015	1,082	1,039	832	1,225	2,027	2,374	817	2,113	945	—	—	—	—	17,531
0300	1,254	1,924	2,094	1,227	1,183	1,017	1,254	2,069	2,511	1,030	2,316	1,017	—	—	—	—	18,896
0330	1,295	1,966	2,137	1,269	1,186	1,022	1,295	2,112	2,554	1,072	2,320	1,022	—	—	—	—	19,251
0360	1,323	1,866	1,792	1,064	1,001	2,098	1,727	1,224	1,323	1,866	1,792	1,064	1,001	2,098	1,727	1,224	24,191
0400	1,380	1,882	1,851	1,285	1,048	2,185	1,813	1,338	1,380	1,882	1,851	1,285	1,048	2,185	1,813	1,338	25,564
0440	1,435	1,938	1,907	1,341	1,051	2,190	1,888	1,274	1,435	1,938	1,907	1,341	1,051	2,190	1,888	1,274	26,049

ALUMINUM FIN COIL WEIGHT DISTRIBUTION BY MODEL (KGS)

YCAS	A	B	C	D	E	F	G	H	I	J	K	L	M	N	O	P	TOTAL
0130	703	607	752	308	714	504	774	318	—	—	—	—	—	—	—	—	4,679
0140	715	615	767	312	732	515	800	323	—	—	—	—	—	—	—	—	4,780
0150	741	557	688	497	814	542	668	603	—	—	—	—	—	—	—	—	5,109
0160	743	549	698	503	815	528	662	605	—	—	—	—	—	—	—	—	5,102
0170	743	558	705	505	816	543	674	607	—	—	—	—	—	—	—	—	5,152
0180	754	557	708	513	833	539	678	621	—	—	—	—	—	—	—	—	5,202
0200	842	616	942	394	899	547	1026	409	—	—	—	—	—	—	—	—	5,676
0210	843	629	948	396	901	569	1033	411	—	—	—	—	—	—	—	—	5,731
0230	845	642	952	398	902	591	1038	413	—	—	—	—	—	—	—	—	5,781
0250	548	826	891	477	471	376	548	912	1066	362	958	428	—	—	—	—	7,863
0270	556	833	914	491	471	377	556	919	1077	370	958	429	—	—	—	—	7,952
0300	569	873	950	556	537	461	569	939	1139	467	1051	461	—	—	—	—	8,571
0330	587	892	969	576	538	464	587	958	1158	486	1052	464	—	—	—	—	8,732
0360	600	846	813	483	454	952	783	555	600	846	813	483	454	952	783	555	10,973
0400	626	854	840	583	476	991	822	607	626	854	840	583	476	991	822	607	11,596
0440	651	879	865	608	477	993	856	578	651	879	865	608	477	993	856	578	11,816

ISOLATOR TYPE & SIZE	MAX LOAD		DEFL.	
	lbs.	kg	in.	mm
AWMR-1-53	1000	453.6	2	51
AWMR-1-530	1150	521.6	2	51
AWMR-1-531	1276	578.8	2	51
AWMR-1-532	1500	680.4	2	51
AWMR-1-551	1676	760.2	2	51
AWMR-1-552	1900	861.8	2	51
AWMR-1-553	2200	997.9	2	51
AWMR-2-520	1300	589.7	2	51
AWMR-2-521	1552	704.0	2	51
AWMR-2-53	2000	907.2	2	51
AWMR-1-530	2300	1043.3	2	51
AWMR-2-531	2552	1157.6	2	51
AWMR-2-532	3000	1360.8	2	51

ISOLATOR TYPE & SIZE	MAX LOAD		DEFL.		SPRING COLOR
	lbs.	kg	in.	mm	
CP-2-25	900	408.2	1.22	30.9	Red
CP-2-26	1200	544.3	1.17	29.7	Purple
CP-2-27	1500	680.4	1.06	26.9	Orange
CP-2-28	1800	816.4	1.02	25.9	Green
CP-2-31	2200	997.9	0.83	21.0	Gray
CP-2-32	2600	1179.3	0.74	18.7	White
CP-2-35	3000	1360.8	0.70	17.7	Gold

Isolator Selection – Aluminum Fin Coils

60 HERTZ, ALUMINUM FINNS, 1" ISOLATOR SELECTIONS – VMC TYPE CP-2-XX

YCAS	A	B	C	D	E	F	G	H	I	J	K	L	M	N	O	P
0130	31	28	31	26	31	27	31	26	—	—	—	—	—	—	—	—
0140	31	28	31	26	31	27	31	26	—	—	—	—	—	—	—	—
0150	31	28	31	27	31	27	31	28	—	—	—	—	—	—	—	—
0160	31	28	31	27	31	27	31	28	—	—	—	—	—	—	—	—
0170	31	28	31	27	31	27	31	28	—	—	—	—	—	—	—	—
0180	31	28	31	27	31	27	31	28	—	—	—	—	—	—	—	—
0200	31	28	32	26	32	28	35	26	—	—	—	—	—	—	—	—
0210	31	28	32	26	32	28	35	26	—	—	—	—	—	—	—	—
0230	31	28	32	26	32	28	35	26	—	—	—	—	—	—	—	—
0250	27	31	32	26	26	26	27	31	32	26	31	26	—	—	—	—
0270	27	31	32	26	26	26	27	31	32	26	31	26	—	—	—	—
0300	27	31	31	27	27	26	27	31	32	26	32	26	—	—	—	—
0330	27	31	31	27	27	26	27	31	32	26	32	26	—	—	—	—
0360	28	31	31	27	26	31	31	27	28	31	31	27	26	31	31	27
0400	28	31	31	27	26	31	31	27	28	31	31	27	26	31	31	27
0440	28	31	31	27	26	31	31	27	28	31	31	27	26	31	31	27

60 HERTZ, ALUMINUM FINNS, NEOPRENE MOUNT SELECTIONS – VMC TYPE RD-4

YCAS	A	B	C	D	E	F	G	H	I	J	K	L	M	N	O	P
0130	RED	BLACK	RED	GREEN*	RED	BLACK	RED	GREEN*	—	—	—	—	—	—	—	—
0140	RED	BLACK	RED	GREEN*	RED	BLACK	RED	GREEN*	—	—	—	—	—	—	—	—
0150	RED	BLACK	RED	BLACK	RED	BLACK	BLACK	BLACK	—	—	—	—	—	—	—	—
0160	RED	BLACK	RED	BLACK	RED	BLACK	BLACK	BLACK	—	—	—	—	—	—	—	—
0170	RED	BLACK	RED	BLACK	RED	BLACK	BLACK	BLACK	—	—	—	—	—	—	—	—
0180	RED	BLACK	RED	BLACK	RED	BLACK	BLACK	BLACK	—	—	—	—	—	—	—	—
0200	RED	BLACK	RED	GRAY*	RED	BLACK	GREEN	GRAY*	—	—	—	—	—	—	—	—
0210	RED	BLACK	RED	GRAY*	RED	BLACK	GREEN	GRAY*	—	—	—	—	—	—	—	—
0230	RED	BLACK	RED	GRAY*	RED	BLACK	GREEN	GRAY*	—	—	—	—	—	—	—	—
0250	BLACK	RED	RED	BLACK	BLACK	BLACK	BLACK	RED	GREEN	BLACK	RED	BLACK	—	—	—	—
0270	BLACK	RED	RED	BLACK	BLACK	BLACK	BLACK	RED	GREEN	BLACK	RED	BLACK	—	—	—	—
0300	BLACK	RED	RED	BLACK	BLACK	BLACK	BLACK	RED	GREEN	BLACK	GREEN	BLACK	—	—	—	—
0330	BLACK	RED	RED	BLACK	BLACK	BLACK	BLACK	RED	GREEN	BLACK	GREEN	BLACK	—	—	—	—
0360	RED	RED	RED	BLACK	BLACK	RED	RED	BLACK	BLACK	RED	RED	BLACK	BLACK	RED	RED	BLACK
0400	RED	RED	RED	BLACK	BLACK	RED	RED	BLACK	BLACK	RED	RED	BLACK	BLACK	RED	RED	BLACK
0440	RED	RED	RED	BLACK	BLACK	RED	RED	BLACK	BLACK	RED	RED	BLACK	BLACK	RED	RED	BLACK

* VMC TYPE RD-3

60 HERTZ, ALUMINUM FINNS, SEISMIC ISOLATOR SELECTIONS - VMC MODEL # AWMR-X-XXX

YCAS	A	B	C	D	E	F	G	H	I	J	K	L	M	N	O	P
0130	-1-552	-1-551	-1-552	-1-53	-1-552	-1-532	-1-553	-1-53	—	—	—	—	—	—	—	—
0140	-1-552	-1-551	-1-552	-1-53	-1-552	-1-532	-1-553	-1-53	—	—	—	—	—	—	—	—
0150	-1-552	-1-551	-1-552	-1-532	-1-553	-1-532	-1-552	-1-532	—	—	—	—	—	—	—	—
0160	-1-552	-1-551	-1-552	-1-532	-1-553	-1-532	-1-552	-1-532	—	—	—	—	—	—	—	—
0170	-1-552	-1-551	-1-552	-1-532	-1-553	-1-532	-1-552	-1-532	—	—	—	—	—	—	—	—
0180	-1-552	-1-551	-1-552	-1-532	-1-553	-1-532	-1-552	-1-532	—	—	—	—	—	—	—	—
0200	-1-553	-1-551	-2-531	-1-530	-1-553	-1-532	-2-531	-1-530	—	—	—	—	—	—	—	—
0210	-1-553	-1-551	-2-531	-1-530	-1-553	-1-532	-2-531	-1-530	—	—	—	—	—	—	—	—
0230	-1-553	-1-551	-2-531	-1-530	-1-553	-1-532	-2-531	-1-530	—	—	—	—	—	—	—	—
0250	-1-532	-1-553	-1-553	-1-531	-1-531	-1-53	-1-532	-1-553	-2-531	-1-53	-1-553	-1-530	—	—	—	—
0270	-1-532	-1-553	-1-553	-1-531	-1-531	-1-53	-1-532	-1-553	-2-531	-1-53	-1-553	-1-530	—	—	—	—
0300	-1-532	-2-530	-1-553	-2-521	-1-532	-1-531	-1-532	-1-553	-2-531	-2-520	-2-531	-1-531	—	—	—	—
0330	-1-532	-2-530	-1-553	-2-521	-1-532	-1-531	-1-532	-1-553	-2-531	-2-520	-2-531	-1-531	—	—	—	—
0360	-1-551	-1-553	-1-553	-1-532	-2-520	-1-553	-1-553	-2-521	-1-551	-1-553	-1-553	-1-531	-2-520	-1-553	-1-553	-2-521
0400	-1-551	-1-553	-1-553	-2-521	-2-520	-1-553	-1-553	-2-521	-1-551	-1-553	-1-553	-2-521	-2-520	-1-553	-1-553	-2-521
0440	-1-551	-1-553	-1-553	-2-521	-2-520	-1-553	-1-553	-2-521	-1-551	-1-553	-1-553	-2-521	-2-520	-1-553	-1-553	-2-521

Operating Weights – Copper Fin Coils

COPPER FIN COIL WEIGHT DISTRIBUTION BY MODEL (LBS)

YCAS	A	B	C	D	E	F	G	H	I	J	K	L	M	N	O	P	TOTAL
0130	1,656	1,515	1,833	853	1,679	1,287	1,883	875	—	—	—	—	—	—	—	—	11,581
0140	1,682	1,532	1,868	863	1,720	1,312	1,940	886	—	—	—	—	—	—	—	—	11,803
0150	1,740	1,403	1,693	1,270	1,900	1,370	1,648	1,505	—	—	—	—	—	—	—	—	12,529
0160	1,743	1,386	1,714	1,284	1,902	1,339	1,636	1,509	—	—	—	—	—	—	—	—	12,513
0170	1,745	1,407	1,730	1,289	1,904	1,374	1,661	1,514	—	—	—	—	—	—	—	—	12,624
0180	1,768	1,403	1,737	1,307	1,942	1,364	1,670	1,544	—	—	—	—	—	—	—	—	12,735
0200	1,988	1,558	2,318	1,092	2,115	1,407	2,502	1,125	—	—	—	—	—	—	—	—	14,105
0210	1,990	1,586	2,328	1,096	2,117	1,453	2,517	1,129	—	—	—	—	—	—	—	—	14,216
0230	1,993	1,614	2,337	1,100	2,120	1,502	2,528	1,133	—	—	—	—	—	—	—	—	14,327
0250	1,315	1,989	2,132	1,204	1,191	1,031	1,315	2,178	2,519	951	2,265	1,145	—	—	—	—	19,235
0270	1,331	2,005	2,183	1,235	1,193	1,033	1,331	2,195	2,542	970	2,267	1,146	—	—	—	—	19,431
0300	1,364	2,108	2,279	1,411	1,367	1,276	1,364	2,254	2,696	1,214	2,501	1,276	—	—	—	—	21,111
0330	1,405	2,151	2,322	1,454	1,371	1,281	1,405	2,296	2,739	1,257	2,505	1,281	—	—	—	—	21,466
0360	1,434	2,040	1,966	1,191	1,096	2,272	1,901	1,462	1,434	2,040	1,966	1,191	1,096	2,272	1,901	1,462	26,722
0400	1,504	2,060	2,029	1,463	1,155	2,381	2,009	1,605	1,504	2,060	2,029	1,463	1,155	2,381	2,009	1,605	28,411
0440	1,559	2,116	2,085	1,519	1,158	2,386	2,014	1,611	1,559	2,116	2,085	1,519	1,158	2,386	2,014	1,611	28,896

COPPER FIN COIL WEIGHT DISTRIBUTION BY MODEL (KGS)

YCAS	A	B	C	D	E	F	G	H	I	J	K	L	M	N	O	P	TOTAL
0130	751	687	831	387	762	584	854	397	—	—	—	—	—	—	—	—	5,253
0140	763	695	847	391	780	595	880	402	—	—	—	—	—	—	—	—	5,354
0150	789	636	768	576	862	621	748	683	—	—	—	—	—	—	—	—	5,683
0160	791	629	777	582	863	607	742	684	—	—	—	—	—	—	—	—	5,676
0170	792	638	785	585	864	623	753	687	—	—	—	—	—	—	—	—	5,726
0180	802	636	788	593	881	619	757	700	—	—	—	—	—	—	—	—	5,776
0200	902	707	1051	495	959	638	1135	510	—	—	—	—	—	—	—	—	6,398
0210	903	719	1056	497	960	659	1142	512	—	—	—	—	—	—	—	—	6,448
0230	904	732	1060	499	962	681	1147	514	—	—	—	—	—	—	—	—	6,499
0250	596	902	967	546	540	468	596	988	1,142	431	1,027	519	0	0	0	0	8,725
0270	604	909	990	560	541	468	604	995	1,153	440	1,028	520	0	0	0	0	8,814
0300	619	956	1,034	640	620	579	619	1,022	1,223	551	1,134	579	0	0	0	0	9,576
0330	637	976	1,053	660	622	581	637	1,042	1,242	570	1,136	581	0	0	0	0	9,737
0360	650	925	892	540	497	1,030	862	663	650	925	892	540	497	1,030	862	663	12,121
0400	682	934	920	663	524	1,080	911	728	682	934	920	663	524	1,080	911	728	12,887
0440	707	960	946	689	525	1,082	913	731	707	960	946	689	525	1,082	913	731	13,107

Isolator Selection – Copper Fin Coils

60 HERTZ, COPPER FINNS, 1" ISOLATOR SELECTIONS – VMC TYPE CP-2-XX																
YCAS	A	B	C	D	E	F	G	H	I	J	K	L	M	N	O	P
0130	31	31	31	26	31	28	32	26	—	—	—	—	—	—	—	—
0140	31	31	31	26	31	28	32	26	—	—	—	—	—	—	—	—
0150	31	28	31	28	31	28	32	31	—	—	—	—	—	—	—	—
0160	31	28	31	28	31	28	32	31	—	—	—	—	—	—	—	—
0170	31	28	31	28	31	28	32	31	—	—	—	—	—	—	—	—
0180	31	28	31	28	31	28	32	31	—	—	—	—	—	—	—	—
0200	32	31	35	27	32	28	35	27	—	—	—	—	—	—	—	—
0210	32	31	35	27	32	28	35	27	—	—	—	—	—	—	—	—
0230	32	31	35	27	32	28	35	27	—	—	—	—	—	—	—	—
0250	28	31	31	27	27	26	27	31	32	26	32	27	—	—	—	—
0270	28	31	31	27	27	26	27	31	32	26	32	27	—	—	—	—
0300	28	31	32	28	28	27	28	32	32	27	32	27	—	—	—	—
0330	28	31	32	28	28	27	28	32	32	27	32	27	—	—	—	—
0360	28	31	31	27	27	32	31	28	31	31	31	27	27	32	31	28
0400	28	31	31	28	27	32	31	31	28	31	31	28	27	32	31	31
0440	28	31	31	28	27	32	31	31	28	31	31	28	27	32	31	31

60 HERTZ, COPPER FINNS, NEOPRENE MOUNT SELECTIONS – VMC TYPE RD-4																
YCAS	A	B	C	D	E	F	G	H	I	J	K	L	M	N	O	P
0130	RED	RED	RED	GRAY*	RED	BLACK	RED	GRAY*	—	—	—	—	—	—	—	—
0140	RED	RED	RED	GRAY*	RED	BLACK	RED	GRAY*	—	—	—	—	—	—	—	—
0150	RED	BLACK	RED	BLACK	RED	BLACK	RED	RED	—	—	—	—	—	—	—	—
0160	RED	BLACK	RED	BLACK	RED	BLACK	RED	RED	—	—	—	—	—	—	—	—
0170	RED	BLACK	RED	BLACK	RED	BLACK	RED	RED	—	—	—	—	—	—	—	—
0180	RED	BLACK	RED	BLACK	RED	BLACK	RED	RED	—	—	—	—	—	—	—	—
0200	RED	RED	GREEN	BLACK	RED	BLACK	RED	BLACK	—	—	—	—	—	—	—	—
0210	RED	RED	RED	BLACK	RED	BLACK	RED	BLACK	—	—	—	—	—	—	—	—
0230	RED	RED	GREEN	BLACK	RED	RED	RED	BLACK	—	—	—	—	—	—	—	—
0250	RED	RED	RED	BLACK	BLACK	BLACK	RED	RED	GREEN	BLACK	GREEN	BLACK	—	—	—	—
0270	RED	RED	RED	BLACK	BLACK	BLACK	RED	RED	GREEN	BLACK	GREEN	BLACK	—	—	—	—
0300	RED	RED	GREEN	RED	RED	BLACK	RED	GREEN	GREEN	BLACK	GREEN	BLACK	—	—	—	—
0330	RED	RED	GREEN	RED	RED	BLACK	RED	GREEN	GREEN	BLACK	GREEN	BLACK	—	—	—	—
0360	RED	RED	RED	BLACK	BLACK	GREEN	RED	RED	RED	RED	RED	BLACK	BLACK	GREEN	RED	RED
0400	RED	RED	RED	RED	BLACK	GREEN	RED	RED	RED	RED	RED	RED	BLACK	BLACK	GREEN	RED
0440	RED	RED	RED	RED	BLACK	GREEN	RED	RED	RED	RED	RED	RED	BLACK	GREEN	RED	RED

* VMC TYPE RD-3

60 HERTZ, COPPER FINNS, SEISMIC ISOLATOR SELECTIONS - VMC MODEL # AWMR-X-XXX																
YCAS	A	B	C	D	E	F	G	H	I	J	K	L	M	N	O	P
0130	-1-553	-1-552	-1-553	-1-530	-1-553	-1-532	-1-553	-1-530	—	—	—	—	—	—	—	—
0140	-1-553	-1-552	-1-553	-1-530	-1-553	-1-532	-1-553	-1-530	—	—	—	—	—	—	—	—
0150	-1-553	-1-552	-1-553	-1-532	-1-553	-1-532	-1-553	-1-552	—	—	—	—	—	—	—	—
0160	-1-553	-1-552	-1-553	-1-532	-1-553	-1-532	-1-553	-1-552	—	—	—	—	—	—	—	—
0170	-1-553	-1-552	-1-553	-1-532	-1-553	-1-532	-1-553	-1-552	—	—	—	—	—	—	—	—
0180	-1-553	-1-552	-1-553	-1-532	-1-553	-1-532	-1-553	-1-552	—	—	—	—	—	—	—	—
0200	-1-553	-1-552	-2-532	-1-532	-1-553	-1-552	-2-532	-1-532	—	—	—	—	—	—	—	—
0210	-1-553	-1-552	-2-532	-1-532	-1-553	-1-552	-2-532	-1-532	—	—	—	—	—	—	—	—
0230	-1-553	-1-552	-2-532	-1-532	-1-553	-1-552	-2-532	-1-532	—	—	—	—	—	—	—	—
0250	-1-551	-1-553	-1-553	-1-532	-1-532	-1-531	-1-551	-1-553	-2-531	-1-530	-2-530	-1-532	—	—	—	—
0270	-1-551	-1-553	-1-553	-1-532	-1-532	-1-531	-1-551	-1-553	-2-531	-1-530	-2-530	-1-532	—	—	—	—
0300	-1-551	-1-553	-2-531	-2-53	-1-532	-1-532	-1-551	-2-530	-2-532	-2-521	-2-531	-1-532	—	—	—	—
0330	-1-551	-1-553	-2-531	-2-53	-1-532	-1-532	-1-551	-2-530	-2-532	-2-521	-2-531	-1-532	—	—	—	—
0360	-1-551	-1-553	-1-553	-1-532	-2-520	-2-530	-1-553	-2-53	-1-551	-1-553	-1-553	-1-532	-2-520	-2-530	-1-553	-2-53
0400	-1-552	-1-553	-1-553	-2-53	-2-521	-2-531	-1-553	-2-53	-1-552	-1-553	-1-553	-2-53	-2-521	-2-531	-1-553	-2-53
0440	-1-552	-1-553	-1-553	-2-53	-2-521	-2-531	-1-553	-2-53	-1-552	-1-553	-1-553	-2-53	-2-521	-2-531	-1-553	-2-53

Isolator Details

R3 / RD3 SERIES

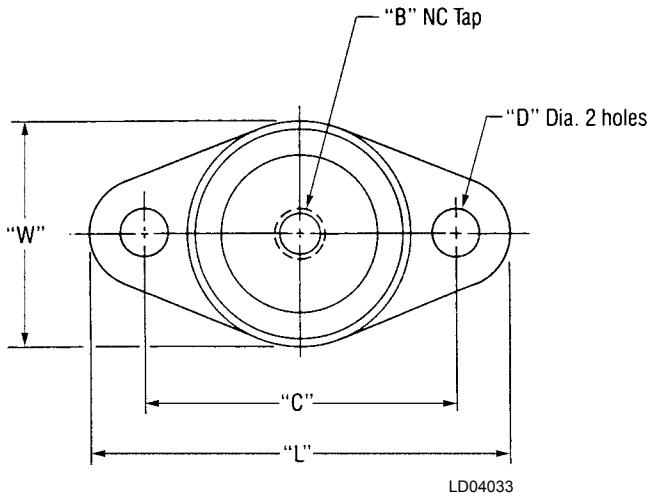

R4 / RD4 SERIES

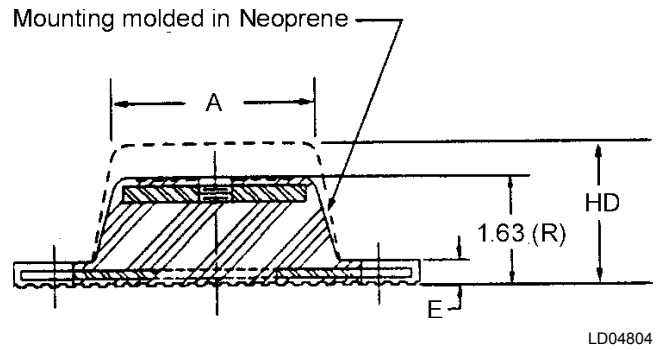
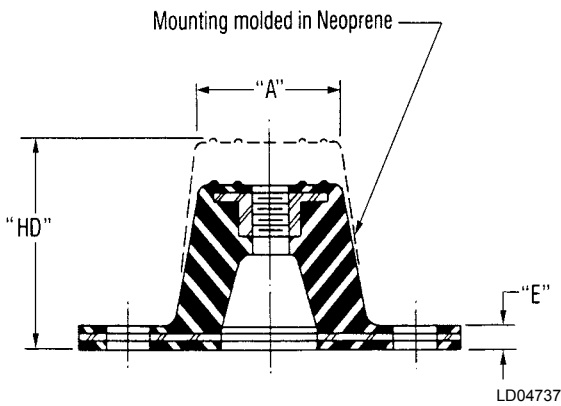
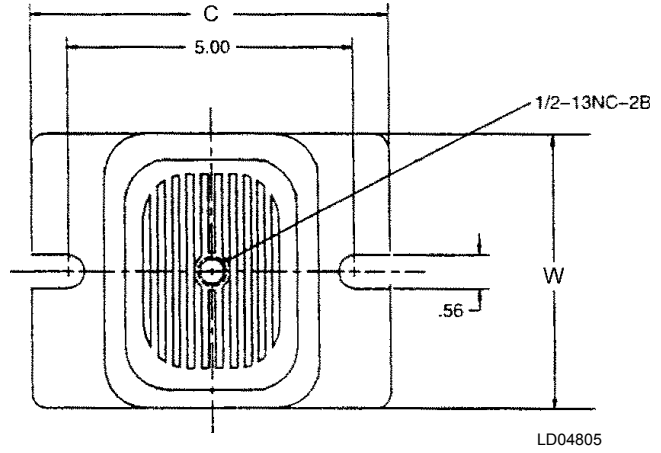

DIMENSIONS: Inches (mm)

TYPE	L	W	HD	A	B	C	D	E
R-3 or RD-3	5.5"	3.375"	2.875"	2.5"	0.5"	4.125"	0.563"	0.25"
	(139.7)	(85.8)	(73.2)	(63.5)	(12.7)	(104.8)	(14.4)	(6.3)
R-4 or RD-4	6.25"	4.625"	2.75"	3.0"	0.5"	5.0"	0.563"	0.375"
	(158.7)	(117.6)	(69.8)	(76.2)	(12.7)	(127.0)	(14.4)	(9.6)

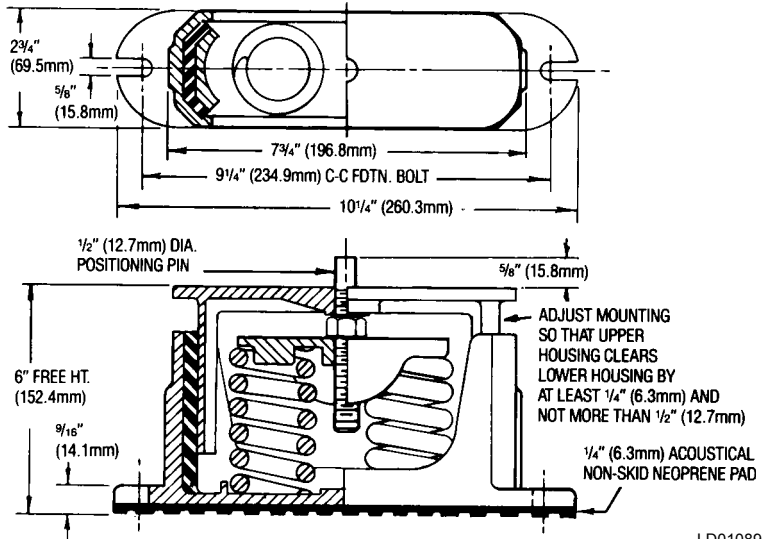

CP-2-XX

LD01089

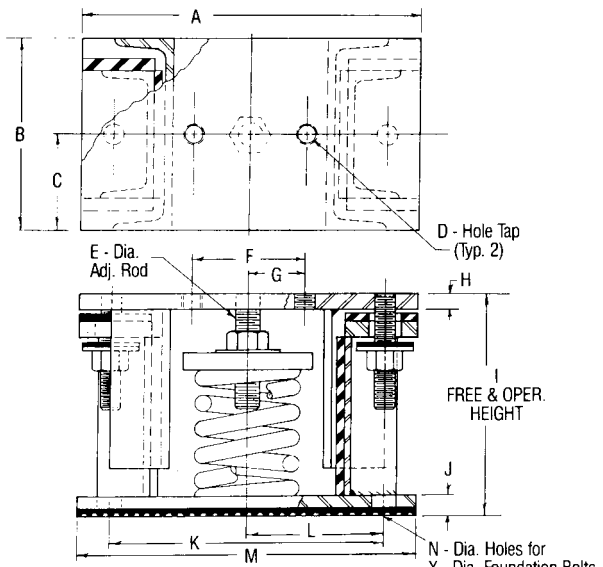

AWMR-1-XXX

LD02973

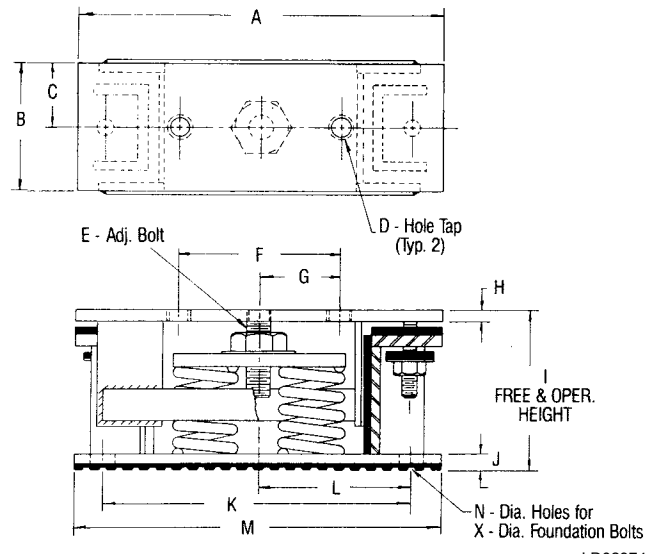

AWMR-2-XXX

LD02974

DIMENSIONS – (In.)

	A	B	C	D	E	F	G	H	I	J	K	L	M	N/X
AWMR-1 50-553	10-1/2	6	3	5/8 11NC	3/4	3-1/2	1-3/4	1/2	9	5/8	8-1/2	4-1/4	10-1/2	3/4 5/8
AWMR-2 50-553	15	6	3	3/4 10NC	1	7-1/2	3-3/4	1/2	9-1/2	5/8	14-1/2	7-1/4	17	3/4 5/8

Electrical Data

MULTIPLE POINT POWER SUPPLY CONNECTION - 2 COMPRESSOR UNITS (SEE FIG. 1)

(Each of Two Field Provided Power Supply Circuits individually protected with Branch Circuit Protection.)

Field Connections to Factory provided Terminal Block (Std), Disconnects (Opt), or Individual System Breakers (Opt) in each of the two Motor Control Centers.)

MODEL YCAS	VOLTS	SYSTEM #1 FIELD-SUPPLIED WIRING												
		FIELD PROVIDED		POWER SUPPLY		FACTORY PROVIDED (LUGS) WIRE RANGE ⁷			COMPRESSOR			FANS ^{11, 12}		
		MCA ¹	MIN NF DISC SW ^{2, 9}	OVER-CURRENT PROTECTION		STD. TERMINAL BLOCK	OPT. NF. DISC SW.	OPT. C.B.	RLA	Y-LRA	X-LRA	QTY	FLA (EA.)	LRA (EA.)
				MIN. ^{3, 5}	MAX. ^{4, 6}									
0130EC	200	340	400	450	500	(2) 1/0 - 300	(2) 3/0-250	(3) 2/0-400	246	591	N/A	4	8.2	38.0
	230	299	400	400	500	2/0 - (2) 4/0	(2) 3/0-250	(2) 3/0-250	214	481	N/A	4	7.8	33.0
	380	181	200	225	300	1/0 - 300	# 6 - 350	# 6 - 350	130	285	900	4	4.8	23.0
	460	150	150	200	250	# 2 - 4/0	# 4 - 300	# 6 - 350	107	228	719	4	4.0	19.0
	575	119	150	150	200	# 2 - 4/0	# 4 - 300	# 4 - 300	86	182	574	4	3.1	15.2
0140EC	200	366	400	450	600	(2) 1/0 - 300	(2) 3/0-250	(3) 2/0-400	267	591	N/A	4	8.2	38.0
	230	321	400	400	500	2/0 - (2) 4/0	(2) 3/0-250	(2) 3/0-250	232	481	N/A	4	7.8	33.0
	380	195	200	250	300	1/0 - 300	# 6 - 350	# 6 - 350	140	285	900	4	4.8	23.0
	460	161	200	200	250	# 2 - 4/0	# 4 - 300	# 4 - 300	116	228	719	4	4.0	19.0
	575	128	150	175	200	# 2 - 4/0	# 4 - 300	# 6 - 350	93	182	574	4	3.1	15.2
0150EC	200	402	400	500	600	(2) 2/0 - 500	(2) 3/0-250	(3) 2/0-400	295	708	N/A	4	8.2	38.0
	230	351	400	450	600	(2) 1/0 - 300	(2) 3/0-250	(3) 2/0-400	256	642	N/A	4	7.8	33.0
	380	213	250	300	350	2/0 - 500	# 6 - 350	(2) 3/0-250	155	343	1093	4	4.8	23.0
	460	176	200	225	300	1/0 - 300	# 4 - 300	# 6 - 350	128	280	893	4	4.0	19.0
	575	141	150	175	225	# 2 - 4/0	# 4 - 300	# 6 - 350	103	224	714	4	3.1	15.2
0160EC	200	402	400	500	600	(2) 2/0 - 500	(2) 3/0-250	(3) 2/0-400	295	708	N/A	4	8.2	38.0
	230	351	400	450	600	(2) 1/0 - 300	(2) 3/0-250	(3) 2/0-400	256	642	N/A	4	7.8	33.0
	380	213	250	300	350	# 1 - 300	# 6 - 350	(2) 3/0-250	155	343	1093	4	4.8	23.0
	460	176	200	225	300	1/0 - 300	# 6 - 350	# 6 - 350	128	280	893	4	4.0	19.0
	575	141	150	175	225	# 2 - 4/0	# 4 - 300	# 6 - 350	103	224	714	4	3.1	15.2
0170EC	200	434	600	600	700	(2) 2/0 - 500	(3) 2/0-400	(3) 2/0-400	321	708	N/A	4	8.2	38.0
	230	380	400	450	600	(2) # 1 - 300	(2) 3/0-250	(3) 2/0-400	279	642	N/A	4	7.8	33.0
	380	230	250	300	350	2/0 - 500	# 6 - 350	(2) 3/0-250	169	343	1093	4	4.8	23.0
	460	191	200	250	300	1/0 - 300	# 6 - 350	# 6 - 350	140	280	893	4	4.0	19.0
	575	152	150	200	250	# 2 - 4/0	# 4 - 300	# 6 - 350	112	224	714	4	3.1	15.2
0180EC	200	434	600	600	700	(2) 2/0 - 500	(3) 2/0-400	(3) 2/0-400	321	708	N/A	4	8.2	38.0
	230	380	400	450	600	(2) 2/0 - 500	(2) 3/0-250	(3) 2/0-400	279	642	N/A	4	7.8	33.0
	380	230	250	300	350	2/0 - 500	# 6 - 350	(2) 3/0-250	169	343	1093	4	4.8	23.0
	460	191	200	250	300	1/0 - 300	# 6 - 350	# 6 - 350	140	280	893	4	4.0	19.0
	575	152	150	200	250	# 2 - 4/0	# 4 - 300	# 6 - 350	112	224	714	4	3.1	15.2
0200EC	200	469	600	600	800	(2) 2/0 - 500	(3) 2/0-400	(3) 2/0-400	342	708	N/A	5	8.2	38.0
	230	412	400	500	700	(2) 2/0 - 500	(2) 3/0-250	(3) 2/0-400	298	642	N/A	5	7.8	33.0
	380	250	250	300	400	2/0 - 500	# 6 - 350	(2) 3/0-250	181	343	1093	5	4.8	23.0
	460	206	200	250	350	# 1 - 300	# 6 - 350	# 6 - 350	149	280	893	5	4.0	19.0
	575	164	200	200	250	1/0 - 300	# 6 - 350	# 6 - 350	119	224	714	5	3.1	15.2
0210EC	200	509	600	700	800	(2) 2/0 - 500	(3) 2/0-400	(3) 2/0-400	374	708	N/A	5	8.2	38.0
	230	445	600	600	700	(2) 2/0 - 500	(3) 2/0-400	(3) 2/0-400	325	642	N/A	5	7.8	33.0
	380	270	400	350	450	2/0 - 500	(2) 3/0-250	(2) 3/0-250	197	343	1093	5	4.8	23.0
	460	224	250	300	350	2/0 - 500	# 6 - 350	(2) 3/0-250	163	280	893	5	4.0	19.0
	575	178	200	225	300	1/0 - 300	# 6 - 350	# 6 - 350	130	224	714	5	3.1	15.2
0230EC	200	509	600	700	800	(2) 2/0 - 500	(3) 2/0-400	(3) 2/0-400	374	708	N/A	5	8.2	38.0
	230	445	600	600	700	(2) 2/0 - 500	(3) 2/0-400	(3) 2/0-400	325	642	N/A	5	7.8	33.0
	380	270	400	350	450	2/0 - 500	(2) 3/0-250	(2) 3/0-250	197	343	1093	5	4.8	23.0
	460	224	250	300	350	2/0 - 500	# 6 - 350	(2) 3/0-250	163	280	893	5	4.0	19.0
	575	178	200	225	300	1/0 - 300	# 6 - 350	# 6 - 350	130	224	714	5	3.1	15.2

MODEL YCAS	VOLTS	SYSTEM #2 FIELD-SUPPLIED WIRING												
		FIELD PROVIDED POWER SUPPLY				FACTORY PROVIDED (LUGS) WIRE RANGE ⁷				COMPRESSOR			FANS ^{11, 12}	
		MCA ¹	MIN NF DISC SW ^{2, 3}	OVER-CURRENT PROTECTION		STD. TERMINAL BLOCK	OPT. NF. DISC SW.	OPT. C.B.	RLA	Y-LRA	X-LRA	QTY	FLA (EA.)	LRA (EA.)
				MIN. ^{3, 5}	MAX. ^{4, 6}									
0130EC	200	343	400	450	500	(2) 1/0 - 300	(2) 3/0-250	(3) 2/0-400	246	591	N/A	4	8.2	38.0
	230	298	400	400	500	2/0 - (2) 4/0	(2) 3/0-250	(2) 3/0-250	214	481	N/A	4	7.8	33.0
	380	180	200	225	300	1/0 - 300	# 6 - 350	# 6 - 350	130	285	900	4	4.8	23.0
	460	149	150	200	250	# 2 - 4/0	# 4 - 300	# 6 - 350	107	228	719	4	4.0	19.0
	575	119	150	150	200	# 2 - 4/0	# 4 - 300	# 4 - 300	86	182	574	4	3.1	15.2
0140EC	200	368	400	450	600	(2) 1/0 - 300	(2) 3/0-250	(3) 2/0-400	267	591	N/A	4	8.2	38.0
	230	320	400	400	500	2/0 - (2) 4/0	(2) 3/0-250	(2) 3/0-250	232	481	N/A	4	7.8	33.0
	380	194	200	250	300	1/0 - 300	# 6 - 350	# 6 - 350	140	285	900	4	4.8	23.0
	460	160	200	200	250	# 2 - 4/0	# 4 - 300	# 6 - 350	116	228	719	4	4.0	19.0
	575	128	150	175	200	# 2 - 4/0	# 4 - 300	# 4 - 300	93	182	574	4	3.1	15.2
0150EC	200	366	400	450	600	(2) 1/0 - 300	(2) 3/0-250	(3) 2/0-400	265	591	N/A	4	8.2	38.0
	230	318	400	400	500	(2) 1/0 - 300	(2) 3/0-250	(2) 3/0-250	230	481	N/A	4	7.8	33.0
	380	192	200	250	300	1/0 - 300	# 6 - 350	# 6 - 350	139	285	900	4	4.8	23.0
	460	159	150	200	250	1/0 - 300	# 6 - 350	# 6 - 350	115	228	719	4	4.0	19.0
	575	127	150	175	200	# 2 - 4/0	# 4 - 300	# 4 - 300	92	182	574	4	3.1	15.2
0160EC	200	404	400	500	600	(2) 2/0 - 500	(2) 3/0-250	(3) 2/0-400	295	708	N/A	4	8.2	38.0
	230	350	400	450	600	(2) 1/0 - 300	(2) 3/0-250	(3) 2/0-400	256	642	N/A	4	7.8	33.0
	380	212	200	300	350	2/0 - 500	# 6 - 350	(2) 3/0-250	155	343	1093	4	4.8	23.0
	460	175	200	225	300	1/0 - 300	# 6 - 350	# 6 - 350	128	280	893	4	4.0	19.0
	575	141	150	175	225	# 2 - 4/0	# 4 - 300	# 6 - 350	103	224	714	4	3.1	15.2
0170EC	200	404	400	500	600	(2) 2/0 - 500	(2) 3/0-250	(3) 2/0-400	295	708	N/A	4	8.2	38.0
	230	350	400	450	600	(2) 1/0 - 300	(2) 3/0-250	(3) 2/0-400	256	642	N/A	4	7.8	33.0
	380	212	200	300	350	# 1 - 300	# 6 - 350	(2) 3/0-250	155	343	1093	4	4.8	23.0
	460	175	200	225	300	1/0 - 300	# 6 - 350	# 6 - 350	128	280	893	4	4.0	19.0
	575	141	150	175	225	# 2 - 4/0	# 4 - 300	# 6 - 350	103	224	714	4	3.1	15.2
0180EC	200	436	600	600	700	(2) 2/0 - 500	(3) 2/0-400	(3) 2/0-400	321	708	N/A	4	8.2	38.0
	230	379	400	450	600	(2) 2/0 - 500	(2) 3/0-250	(3) 2/0-400	279	642	N/A	4	7.8	33.0
	380	230	250	300	350	2/0 - 500	# 6 - 350	(2) 3/0-250	169	343	1093	4	4.8	23.0
	460	190	200	250	300	1/0 - 300	# 6 - 350	# 6 - 350	140	280	893	4	4.0	19.0
	575	152	150	200	250	# 2 - 4/0	# 4 - 300	# 6 - 350	112	224	714	4	3.1	15.2
0200EC	200	471	600	600	800	(2) 2/0 - 500	(3) 2/0-400	(3) 2/0-400	342	708	N/A	5	8.2	38.0
	230	411	400	500	700	(2) 2/0 - 500	(2) 3/0-250	(3) 2/0-400	298	642	N/A	5	7.8	33.0
	380	249	250	300	400	2/0 - 500	# 6 - 350	(2) 3/0-250	181	343	1093	5	4.8	23.0
	460	205	200	250	350	2/0 - 500	# 6 - 350	# 6 - 350	149	280	893	5	4.0	19.0
	575	164	200	200	250	1/0 - 300	# 6 - 350	# 6 - 350	119	224	714	5	3.1	15.2
0210EC	200	471	600	600	800	(2) 2/0 - 500	(3) 2/0-400	(3) 2/0-400	342	708	N/A	5	8.2	38.0
	230	411	400	500	700	(2) 2/0 - 500	(2) 3/0-250	(3) 2/0-400	298	642	N/A	5	7.8	33.0
	380	249	250	300	400	2/0 - 500	# 6 - 350	(2) 3/0-250	181	343	1093	5	4.8	23.0
	460	205	200	250	350	# 1 - 300	# 6 - 350	# 6 - 350	149	280	893	5	4.0	19.0
	575	164	200	200	250	1/0 - 300	# 4 - 300	# 6 - 350	119	224	714	5	3.1	15.2
0230EC	200	511	600	700	800	(2) 2/0 - 500	(3) 2/0-400	(3) 2/0-400	374	708	N/A	5	8.2	38.0
	230	444	600	600	700	(2) 2/0 - 500	(3) 2/0-400	(3) 2/0-400	325	642	N/A	5	7.8	33.0
	380	269	400	350	450	2/0 - 500	(2) 3/0-250	(2) 3/0-250	197	343	1093	5	4.8	23.0
	460	223	250	300	350	2/0 - 500	# 6 - 350	(2) 3/0-250	163	280	893	5	4.0	19.0
	575	178	200	225	300	1/0 - 300	# 6 - 350	# 6 - 350	130	224	714	5	3.1	15.2

Electrical Data

MULTIPLE POINT POWER SUPPLY CONNECTION - 3 & 4 Compressor Units (Two Field Provided Power Supply Circuits to the Chiller. Field Connections to Factory provided Terminal Block (Std) or Disconnects (Opt) in the Options Panel. Circuit Breaker (Opt¹⁰) in each of the two Motor Control Centers.)

CHILLER MODEL YCAS	VOLTS	ELECTRICAL SYSTEM #1 FIELD SUPPLIED WIRING														
		FIELD PROVIDED POWER SUPPLY				FACTORY PROVIDED (LUGS) WIRE RANGE ⁷		COMPRESSOR #1			COMPRESSOR #3			FAN ^{11, 12} DATA		
		MCA ¹	MIN NF DISC SW ^{2, 9}	OVER-CURRENT PROTECTION		STANDARD TERMINAL BLOCK	OPTIONAL NF DISC. SWITCH	RLA	Y-Δ LRA	X-LRA	RLA	Y-Δ LRA	X-LRA	QTY	FLA(EA)	LRA(EA)
				MIN. ^{3, 5}	MAX. ^{4, 6}											
0250EC	380	387	400	450	500	(2) # 2-300	(2) 3/0-250	155	343	1,093	155	343	1,093	8	4.8	23.0
	460	320	400	400	400	(1)2/0-(2)4/0	(2) 3/0-250	128	280	893	128	280	893	8	4.0	19.0
	575	257	400	300	350	(1)2/0-(2)4/0	(2) 3/0-250	103	224	714	103	224	714	8	3.1	15.2
0270EC	380	477	600	600	700	(2) # 2-300	(2) 250-500	155	343	1,093	227	343	1,093	8	4.8	23.0
	460	390	400	450	500	(2) # 2-300	(2) 3/0-250	128	280	893	184	280	893	8	4.0	19.0
	575	312	400	350	450	(1)2/0-(2)4/0	(2) 3/0-250	103	224	714	147	224	714	8	3.1	15.2
0300EC	380	473	600	600	600	(2) # 2-300	(2) 250-500	181	343	1,093	199	343	1,093	9	4.8	23.0
	460	390	400	450	500	(2) # 2-300	(2) 3/0-250	149	280	893	164	280	893	9	4.0	19.0
	575	311	400	350	400	(1)2/0-(2)4/0	(2) 3/0-250	119	224	714	131	224	714	9	3.1	15.2
0330EC	380	524	600	600	700	(2)2/0-500	(2) 250-500	197	343	1,093	227	343	1,093	9	4.8	23.0
	460	429	600	500	600	(2) # 2-300	(2) 250-500	163	280	893	184	280	893	9	4.0	19.0
	575	342	400	400	500	(1)2/0-(2)4/0	(2) 3/0-250	130	224	714	147	224	714	9	3.1	15.2
0360EC	380	442	600	500	600	(2) # 2-300	(2) 250-500	199	343	1,093	155	343	1,093	8	4.8	23.0
	460	365	400	450	500	(1)2/0-(2)4/0	(2) 3/0-250	164	280	893	128	280	893	8	4.0	19.0
	575	292	400	350	400	2/0-500	(2) 3/0-250	131	224	714	103	224	714	8	3.1	15.2
0400EC	380	473	600	600	600	(2) # 2-300	(2) 250-500	181	343	1,093	199	343	1,093	9	4.8	23.0
	460	390	400	450	500	(2) # 2-300	(2) 3/0-250	149	280	893	164	280	893	9	4.0	19.0
	575	311	400	350	400	2/0-500	(2) 3/0-250	119	224	714	131	224	714	9	3.1	15.2
0440EC	380	524	600	600	700	(2)2/0-500	(2) 250-500	197	343	1,093	227	343	1,093	9	4.8	23.0
	460	429	600	500	600	(2) # 2-300	(2) 250-500	163	280	893	184	280	893	9	4.0	19.0
	575	342	400	400	450	(1)2/0-(2)4/0	(2) 3/0-250	130	224	714	147	224	714	9	3.1	15.2

CHILLER MODEL YCAS	VOLTS	ELECTRICAL SYSTEM #2 FIELD SUPPLIED WIRING														
		FIELD PROVIDED POWER SUPPLY				FACTORY PROVIDED (LUGS) WIRE RANGE		COMPRESSOR #2			COMPRESSOR #4			FAN ^{11, 12} DATA		
		MCA ¹	MIN NF DISC SW ^{2,9}	OVER-CURRENT PROTECTION ¹³		STANDARD TERMINAL BLOCK	OPTIONAL NF DISC. SWITCH	RLA	Y-Δ LRA	X-LRA	RLA	Y-Δ LRA	X-LRA	QTY	FLA(EA)	LRA(EA)
				MIN. ^{3,5}	MAX. ^{4,6}											
0250EC	380	213	200	300	350	# 2-300	# 4-300	155	343	1,093	—	—	—	4	4.8	23.0
	460	176	175	225	300	# 2-4/0	# 4-300	128	280	893	—	—	—	4	4.0	19.0
	575	141	150	175	225	# 2-4/0	# 4-300	103	224	714	—	—	—	4	3.1	15.2
0270EC	380	213	200	300	350	# 2-300	# 4-300	155	343	1,093	—	—	—	4	4.8	23.0
	460	176	175	225	300	# 2-4/0	# 4-300	128	280	893	—	—	—	4	4.0	19.0
	575	141	150	175	225	# 2-4/0	# 4-300	103	224	714	—	—	—	4	3.1	15.2
0300EC	380	250	250	300	400	# 2-300	# 6-350	181	343	1,093	—	—	—	5	4.8	23.0
	460	206	200	250	350	# 2-300	# 4-300	149	280	893	—	—	—	5	4.0	19.0
	575	164	175	200	250	# 2-4/0	# 6-350	119	224	714	—	—	—	5	3.1	15.2
0330EC	380	270	400	350	450	2/0-500	(2) 3/0-250	197	343	1,093	—	—	—	5	4.8	23.0
	460	224	225	300	350	# 2-300	# 4-300	163	280	893	—	—	—	5	4.0	19.0
	575	178	175	225	300	# 2-4/0	# 6-350	130	224	714	—	—	—	5	3.1	15.2
0360EC	380	442	600	500	600	(2) 2-300	(2) 250-500	199	343	1,093	155	343	1,093	8	4.8	23.0
	460	365	400	450	500	(1)2/0-(2)4/0	(2) 3/0-250	164	280	893	128	280	893	8	4.0	19.0
	575	292	400	350	400	2/0-500	(2) 3/0-250	131	224	714	103	224	714	8	3.1	15.2
0400EC	380	473	600	600	600	(2) # 2-300	(2) 250-500	181	343	1,093	199	343	1,093	9	4.8	23.0
	460	390	400	450	500	(1)2/0-(2)4/0	(2) 3/0-250	149	280	893	164	280	893	9	4.0	19.0
	575	311	400	350	400	2/0-500	(2) 3/0-250	119	224	714	131	224	714	9	3.1	15.2
0440EC	380	524	600	600	700	(2)2/0-500	(2) 250-500	197	343	1,093	227	343	1,093	9	4.8	23.0
	460	429	600	500	600	(2) # 2-300	(2) 250-500	163	280	893	184	280	893	9	4.0	19.0
	575	342	400	400	450	(1)2/0-(2)4/0	(2) 3/0-250	130	224	714	147	224	714	9	3.1	15.2

Electrical Data (Continued)

OPTIONAL SINGLE-POINT POWER SUPPLY WITH INDIVIDUAL SYSTEM CIRCUIT BREAKERS – 2 COMPRESSOR UNITS (SEE FIG. 2)

(One Field Provided Power Supply Circuit to the chiller. Field connections to Power Terminal Block or Non-Fused Disconnect in 'Option Panel'.
Individual Branch Circuit Protection (Breakers) per Motor Control Center¹⁰)

CHILLER MODEL YCAS	VOLTS	FIELD-SUPPLIED WIRING					
		FIELD PROVIDED POWER SUPPLY				FACTORY PROVIDED (LUGS) WIRE RANGE ⁷	
		MCA ¹	MIN NF DISC SW ^{2,9}	OVER-CURRENT PROTECTION ¹³		STANDARD TERMINAL BLOCK	OPTIONAL NF DISC. SWITCH
MIN. ^{3,5}	MAX. ^{4,6}						
0130EC	200	619.3	800	700	700	(3) 2/0 - 500	(3) 2/0-400
	230	543.9	600	600	700	(2) 2/0 - 500	(2) 250-500
	380	329.8	400	400	450	(2) 1/0 - 300	(2) 3/0-250
	460	272.8	400	300	350	2/0 - 500	(2) 3/0-250
	575	217.4	250	250	300	2/0 - 500	# 6 - 350
0140EC	200	665.9	800	800	800	(3) 2/0 - 500	(3) 2/0-400
	230	584.4	800	700	800	(3) 2/0 - 500	(2) 250-500
	380	354.3	400	400	450	(2) 1/0 - 300	(2) 3/0-250
	460	293.0	400	350	400	(2) 1/0 - 300	(2) 3/0-250
	575	233.6	250	300	300	2/0 - 500	# 6 - 350
0150EC	200	698.9	800	800	800	(3) 2/0 - 500	(3) 2/0-400
	230	612.4	800	700	800	(3) 2/0 - 500	(3) 2/0-400
	380	371.4	400	450	500	(2) 2/0 - 500	(2) 3/0-250
	460	307.0	400	350	400	(2) 1/0 - 300	(2) 3/0-250
	575	245.6	400	300	300	2/0 - 500	(2) 3/0-250
0160EC	200	729.4	800	1000	800	(3) 2/0 - 500	(3) 2/0-400
	230	638.4	800	800	800	(3) 2/0 - 500	(3) 2/0-400
	380	387.2	600	450	500	(2) 2/0 - 500	(2) 250-500
	460	320.0	400	400	400	(2) 1/0 - 300	(2) 3/0-250
	575	256.6	400	300	300	2/0 - 500	(2) 3/0-250
0170EC	200	761.9	800	1000	1000	(3) 2/0 - 500	(3) 2/0-400
	230	667.2	800	800	800	(3) 2/0 - 500	(3) 2/0-400
	380	404.7	600	450	500	(2) 2/0 - 500	(2) 250-500
	460	335.0	400	400	400	(2) 1/0 - 300	(2) 3/0-250
	575	267.8	400	300	350	2/0 - 500	(2) 3/0-250
0180EC	200	787.9	1000	1000	1000	N/A	N/A
	230	690.2	800	800	800	N/A	N/A
	380	418.7	600	500	500	(2) 2/0 - 500	(2) 250-500
	460	347.0	400	400	450	(2) 1/0 - 300	(2) 3/0-250
	575	276.8	400	350	350	(2) 1/0 - 300	(2) 3/0-250
0200EC	200	851.5	1000	1000	1000	N/A	N/A
	230	748.5	800	1000	800	N/A	N/A
	380	455.3	600	600	500	(2) 2/0 - 500	(2) 250-500
	460	375.3	400	450	450	(2) 2/0 - 500	(2) 3/0-250
	575	298.8	400	350	350	(2) 1/0 - 300	(2) 3/0-250
0210EC	200	891.5	1000	1000	1000	N/A	N/A
	230	782.3	1000	1000	1000	N/A	N/A
	380	475.3	600	600	600	(2) 2/0 - 500	(2) 250-500
	460	392.8	600	450	500	(2) 2/0 - 500	(2) 250-500
	575	312.5	400	350	400	(2) 1/0 - 300	(2) 3/0-250
0230EC	200	923.5	1000	1200	1200	N/A	N/A
	230	809.3	1000	1000	1000	N/A	N/A
	380	491.3	600	600	600	(2) 2/0 - 500	(2) 250-500
	460	406.8	600	450	500	(2) 2/0 - 500	(2) 250-500
	575	323.5	400	400	450	(2) 1/0 - 300	(2) 3/0-250

MODEL YCAS	VOLTS	SYSTEM #1						SYSTEM #2					
		COMPRESSOR DATA			FAN DATA ^{11, 12}			COMPRESSOR DATA			FAN DATA ^{11, 12}		
		RLA	Y-LRA	X-LRA	QTY	FLA (EA.)	LRA (EA)	RLA	Y-LRA	X-LRA	QTY	FLA (EA)	LRA (EA)
0130EC	200	246.1	591	1866	4	8.2	38.0	246.1	591	1866	4	8.2	38.0
	230	214.0	481	1518	4	7.8	33.0	214.0	481	1518	4	7.8	33.0
	380	129.5	285	900	4	4.8	23.0	129.5	285	900	4	4.8	23.0
	460	107.0	228	719	4	4.0	19.0	107.0	228	719	4	4.0	19.0
	575	85.6	182	574	4	3.1	15.2	85.6	182	574	4	3.1	15.2
0140EC	200	266.8	591	1866	4	8.2	38.0	266.8	591	1866	4	8.2	38.0
	230	232.0	481	1518	4	7.8	33.0	232.0	481	1518	4	7.8	33.0
	380	140.4	285	900	4	4.8	23.0	140.4	285	900	4	4.8	23.0
	460	116.0	228	719	4	4.0	19.0	116.0	228	719	4	4.0	19.0
	575	92.8	182	574	4	3.1	15.2	92.8	182	574	4	3.1	15.2
0150EC	200	295.0	708	2256	4	8.2	38.0	264.5	591	1866	4	8.2	38.0
	230	256.0	642	2045	4	7.8	33.0	230.0	481	1518	4	7.8	33.0
	380	155.0	343	1093	4	4.8	23.0	139.2	285	900	4	4.8	23.0
	460	128.0	280	893	4	4.0	19.0	115.0	228	719	4	4.0	19.0
	575	103.0	224	714	4	3.1	15.2	92.0	182	574	4	3.1	15.2
0160EC	200	295.0	708	2256	4	8.2	38.0	295.0	708	2256	4	8.2	38.0
	230	256.0	642	2045	4	7.8	33.0	256.0	642	2045	4	7.8	33.0
	380	155.0	343	1093	4	4.8	23.0	155.0	343	1093	4	4.8	23.0
	460	128.0	280	893	4	4.0	19.0	128.0	280	893	4	4.0	19.0
	575	103.0	224	714	4	3.1	15.2	103.0	224	714	4	3.1	15.2
0170EC	200	321.0	708	2256	4	8.2	38.0	295.0	708	2256	4	8.2	38.0
	230	279.0	642	2045	4	7.8	33.0	256.0	642	2045	4	7.8	33.0
	380	169.0	343	1093	4	4.8	23.0	155.0	343	1093	4	4.8	23.0
	460	140.0	280	893	4	4.0	19.0	128.0	280	893	4	4.0	19.0
	575	112.0	224	714	4	3.1	15.2	103.0	224	714	4	3.1	15.2
0180EC	200	321.0	N/A	N/A	4	8.2	38.0	321.0	N/A	N/A	4	8.2	38.0
	230	279.0	N/A	N/A	4	7.8	33.0	279.0	N/A	N/A	4	7.8	33.0
	380	169.0	343	1093	4	4.8	23.0	169.0	343	1093	4	4.8	23.0
	460	140.0	280	893	4	4.0	19.0	140.0	280	893	4	4.0	19.0
	575	112.0	224	714	4	3.1	15.2	112.0	224	714	4	3.1	15.2
0200EC	200	342.0	N/A	N/A	5	8.2	38.0	342.0	N/A	N/A	5	8.2	38.0
	230	298.0	N/A	N/A	5	7.8	33.0	298.0	N/A	N/A	5	7.8	33.0
	380	181.0	343	1093	5	4.8	23.0	181.0	343	1093	5	4.8	23.0
	460	149.0	280	893	5	4.0	19.0	149.0	280	893	5	4.0	19.0
	575	119.0	224	714	5	3.1	15.2	119.0	224	714	5	3.1	15.2
0210EC	200	374.0	N/A	N/A	5	8.2	38.0	342.0	N/A	N/A	5	8.2	38.0
	230	325.0	N/A	N/A	5	7.8	33.0	298.0	N/A	N/A	5	7.8	33.0
	380	197.0	343	1093	5	4.8	23.0	181.0	343	1093	5	4.8	23.0
	460	163.0	280	893	5	4.0	19.0	149.0	280	893	5	4.0	19.0
	575	130.0	224	714	5	3.1	15.2	119.0	224	714	5	3.1	15.2
0230EC	200	374.0	N/A	N/A	5	8.2	38.0	374.0	N/A	N/A	5	8.2	38.0
	230	325.0	N/A	N/A	5	7.8	33.0	325.0	N/A	N/A	5	7.8	33.0
	380	197.0	343	1093	5	4.8	23.0	197.0	343	1093	5	4.8	23.0
	460	163.0	280	893	5	4.0	19.0	163.0	280	893	5	4.0	19.0
	575	130.0	224	714	5	3.1	15.2	130.0	224	714	5	3.1	15.2

Electrical Data (Continued)

OPTIONAL SINGLE-POINT POWER SUPPLY CONNECTION – 2 COMPRESSOR UNITS (SEE FIG. 3)

(One Field Provided Power Supply Circuit to the chiller. Field connections to Power Terminal Block or Non-Fused Disconnect in 'Option Panel'.
No Internal Branch Circuit Protection (Breakers) per Motor Control Center¹⁰)

CHILLER MODEL YCAS	VOLTS	FIELD-SUPPLIED WIRING					
		FIELD PROVIDED POWER SUPPLY			FACTORY PROVIDED (LUGS) WIRE RANGE ⁷		
		MCA ¹	MIN NF DISC SW ^{2,9}	OVER-CURRENT PROTECTION ¹³		STANDARD TERMINAL BLOCK	OPTIONAL NF DISC. SWITCH
MIN. ^{3,5}	MAX. ^{4,6}						
0130EC	460	273	400	300	350	# 1 - 500	(2) 3/0-250
	575	217	250	250	300	# 1 - 500	# 6 - 350
0140EC	460	293	400	350	400	(2) # 2 - 300	(2) 3/0-250
	575	234	250	300	300	# 1 - 500	# 6 - 350
0150EC	460	307	400	350	400	(2) # 2 - 300	(2) 3/0-250
	575	246	400	300	300	# 1 - 500	(2) 3/0-250
0160EC	460	320	400	400	400	(2) # 2 - 300	(2) 3/0-250
	575	257	400	300	350	# 1 - 500	(2) 3/0-250
0170EC	460	335	400	400	450	(2) # 2 - 300	(2) 3/0-250
	575	268	400	300	350	# 1 - 500	(2) 3/0-250
0180EC	460	347	400	400	450	(2) # 2 - 300	(2) 3/0-250
	575	277	400	350	350	(2) # 2 - 300	(2) 3/0-250
0200EC	460	375	400	450	500	(2) # 1 - 500	(2) 3/0-250
	575	299	400	350	400	(2) # 2 - 300	(2) 3/0-250
0210EC	460	393	600	450	500	(2) # 1 - 500	(2) 250-500
	575	313	400	350	400	(2) # 2 - 300	(2) 3/0-250
0230EC	460	407	600	450	500	(2) # 1 - 500	(2) 250-500
	575	324	400	400	450	(2) # 2 - 300	(2) 3/0-250

OPTIONAL SINGLE-POINT POWER SUPPLY CONNECTION WITH INTERNAL UNIT CIRCUIT BREAKERS 3 & 4 Compressor Units

(One Field Provided Power Supply Circuit to the chiller. Field connections to Power Terminal Block (standard) or Non-Fused Disconnect (option)
in 'Option Panel'. Circuit Breakers in each Motor Control Center

CHILLER MODEL YCAS	VOLTS	FIELD SUPPLIED WIRING					
		FIELD PROVIDED POWER SUPPLY			FACTORY PROVIDED (LUGS) WIRE RANGE ⁷		
		MCA ¹	MIN NF DISC SW ^{2,9}	OVER-CURRENT PROTECTION ¹³		TERMINAL BLOCK (LUGS) WIRE RANGE	NF DISC. SWITCH (LUGS) WIRE RANGE
MIN. ^{3,5}	MAX. ^{4,6}						
0250EC	380	561	600	600	700	(2) 2/0-500	(2) 250-500
	460	464	600	500	500	(2) 1/0-300	(2) 250-500
	575	372	400	400	450	(2) # 2-4/0	(3) 2/0-250
0270EC	380	651	800	800	800	(2) 2/0-500	(3) 2/0-400
	460	534	600	600	700	(2) 2/0-500	(2) 250-500
	575	427	600	500	500	(2) 1/0-300	(2) 250-500
0300EC	380	678	800	800	800	(3) 1/0-300	(3) 2/0-400
	460	559	600	600	700	(2) 2/0-500	(2) 250-500
	575	445	600	500	500	(2) 1/0-500	(2) 250-500
0330EC	380	745	800	800	800	(3) 1/0-300	(3) 2/0-400
	460	612	800	700	700	(2) 2/0-500	(3) 2/0-400
	575	487	600	600	600	(2) 1/0-300	(2) 250-500
0360EC	380	835	1000	1000	1000	(3) 2/0-500	(4) 4/0-500
	460	689	800	800	800	(3) 1/0-300	(3) 2/0-400
	575	550	600	600	600	(2) 2/0-500	(2) 250-500
0400EC	380	896	1000	1000	1000	(3) 2/0-500	(4) 4/0-500
	460	739	1000	800	800	(3) 2/0-500	(4) 4/0-500
	575	589	800	700	700	(2) 2/0-500	(3) 2/0-400
0440EC	380	991	1200	1200	1200	(3) 2/0-500	(4) 4/0-500
	460	812	1000	1000	1000	(3) 2/0-500	(4) 4/0-500
	575	647	800	800	800	(2) 2/0-500	(3) 2/0-400

See page 89 for Electrical Data footnotes.

MODEL YCAS	VOLTS	SYSTEM #1					SYSTEM #2				
		COMPRESSOR DATA		FAN DATA ^{11,12}			COMPRESSOR DATA		FAN DATA ^{11,12}		
		RLA	X-LRA	QTY	FLA (EA.)	LRA (EA)	RLA	X-LRA	QTY	FLA (EA)	LRA (EA)
0130EC	460	107	719	4	4.0	19.0	107	719	4	4.0	19.0
	575	86	574	4	3.1	15.2	86	574	4	3.1	15.2
0140EC	460	116	719	4	4.0	19.0	116	719	4	4.0	19.0
	575	93	574	4	3.1	15.2	93	574	4	3.1	15.2
0150EC	460	128	893	4	4.0	19.0	115	719	4	4.0	19.0
	575	103	714	4	3.1	15.2	92	574	4	3.1	15.2
0160EC	460	128	893	4	4.0	19.0	128	893	4	4.0	19.0
	575	103	714	4	3.1	15.2	103	714	4	3.1	15.2
0170EC	460	140	893	4	4.0	19.0	128	893	4	4.0	19.0
	575	112	714	4	3.1	15.2	103	714	4	3.1	15.2
0180EC	460	140	893	4	4.0	19.0	140	893	4	4.0	19.0
	575	112	714	4	3.1	15.2	112	714	4	3.1	15.2
0200EC	460	149	893	5	4.0	19.0	149	893	5	4.0	19.0
	575	119	714	5	3.1	15.2	119	714	5	3.1	15.2
0210EC	460	163	893	5	4.0	19.0	149	893	5	4.0	19.0
	575	130	714	5	3.1	15.2	119	714	5	3.1	15.2
0230EC	460	163	893	5	4.0	19.0	163	893	5	4.0	19.0
	575	130	714	5	3.1	15.2	130	714	5	3.1	15.2

ELECTRICAL SYSTEM #1 FIELD SUPPLIED WIRING									ELECTRICAL SYSTEM #2 FIELD SUPPLIED WIRING								
COMPRESSOR #1 DATA			COMPRESSOR #3 DATA			FAN DATA ^{11,12}			COMPRESSOR #2 DATA			COMPRESSOR #4 DATA			FAN DATA ^{11,12}		
RLA	Y-Δ LRA	X-LRA	RLA	Y-Δ LRA	X-LRA	QTY	FLA (EA)	LRA (EA)	RLA	Y-Δ LRA	X-LRA	RLA	Y-Δ LRA	X-LRA	QTY	FLA (EA)	LRA(EA)
155	343	1,093	155	343	1,093	8	4.8	23.0	155	343	1,093	—	—	—	4	4.8	23.0
128	280	893	128	280	893	8	4.0	19.0	128	280	893	—	—	—	4	4.0	19.0
103	224	714	103	224	714	8	3.1	15.2	103	224	714	—	—	—	4	3.1	15.2
155	343	1,093	227	343	1,093	8	4.8	23.0	155	343	1,093	—	—	—	4	4.8	23.0
128	280	893	184	280	893	8	4.0	19.0	128	280	893	—	—	—	4	4.0	19.0
103	224	714	147	224	714	8	3.1	15.2	103	224	714	—	—	—	4	3.1	15.2
181	343	1,093	199	343	1,093	9	4.8	23.0	181	343	1,093	—	—	—	5	4.8	23.0
149	280	893	164	280	893	9	4.0	19.0	149	280	893	—	—	—	5	4.0	19.0
119	224	714	131	224	714	9	3.1	15.2	119	224	714	—	—	—	5	3.1	15.2
197	343	1,093	227	343	1,093	9	4.8	23.0	197	343	1,093	—	—	—	5	4.8	23.0
163	280	893	184	280	893	9	4.0	19.0	163	280	893	—	—	—	5	4.0	19.0
130	224	714	147	224	714	9	3.1	15.2	130	224	714	—	—	—	5	3.1	15.2
199	343	1,093	155	343	1,093	8	4.8	23.0	199	343	1,093	155	343	1,093	8	4.8	23.0
164	280	893	128	280	893	8	4.0	19.0	164	280	893	128	280	893	8	4.0	19.0
131	224	714	103	224	714	8	3.1	15.2	131	224	714	103	224	714	8	3.1	15.2
181	343	1,093	199	343	1,093	9	4.8	23.0	181	343	1,093	199	343	1,093	9	4.8	23.0
149	280	893	164	280	893	9	4.0	19.0	149	280	893	164	280	893	9	4.0	19.0
119	224	714	131	224	714	9	3.1	15.2	119	224	714	131	224	714	9	3.1	15.2
197	343	1,093	227	343	1,093	9	4.8	23.0	197	343	1,093	227	343	1,093	9	4.8	23.0
163	280	893	184	280	893	9	4.0	19.0	163	280	893	184	280	893	9	4.0	19.0
130	224	714	147	224	714	9	3.1	15.2	130	224	714	147	224	714	9	3.1	15.2

Electrical Data (Continued)

OPTIONAL SINGLE-POINT POWER SUPPLY CONNECTION TO FACTORY CIRCUIT BREAKER – 2 COMPRESSOR UNITS (SEE FIG.4)

(One Field Provided Power Supply Circuit to the chiller. Field Connection to Circuit Breaker in 'Option Panel'.
No internal Individual System Circuit Protection per Motor Control Center¹⁰.)

MODEL YCAS	VOLTS	FIELD SUPPLIED WIRING			SYSTEM #1					SYSTEM #2				
		MCA ¹	FACTORY SUPPLIED BREAKER		COMPRESSOR		FANS ^{11, 12}			COMPRESSOR		FANS ^{11, 12}		
			RATING ²	WIRE RANGE ³ (LUGS)	RLA	X-LRA	QTY	FLA(ea)	LRA(ea)	RLA	X-LRA	QTY	FLA(ea)	LRA(ea)
0130EC	460	273	400	(2) 3/0-250	107	719	4	4.0	19.0	107	719	4	4.0	19.0
	575	217	250	# 6 - 350	86	574	4	3.1	15.2	86	574	4	3.1	15.2
0140EC	460	293	400	(2) 3/0-250	116	719	4	4.0	19.0	116	719	4	4.0	19.0
	575	234	400	(2) 3/0-250	93	574	4	3.1	15.2	93	574	4	3.1	15.2
0150EC	460	307	400	(2) 3/0-250	128	893	4	4.0	19.0	115	719	4	4.0	19.0
	575	246	400	(2) 3/0-250	103	714	4	3.1	15.2	92	574	4	3.1	15.2
0160EC	460	320	400	(2) 3/0-250	128	893	4	4.0	19.0	128	893	4	4.0	19.0
	575	257	400	(2) 3/0-250	103	714	4	3.1	15.2	103	714	4	3.1	15.2
0170EC	460	335	400	(2) 3/0-250	140	893	4	4.0	19.0	128	893	4	4.0	19.0
	575	268	400	(2) 3/0-250	112	714	4	3.1	15.2	103	714	4	3.1	15.2
0180EC	460	347	400	(2) 3/0-250	140	893	4	4.0	19.0	140	893	4	4.0	19.0
	575	277	400	(2) 3/0-250	112	714	4	3.1	15.2	112	714	4	3.1	15.2
0200EC	460	375	600	(3) 2/0-400	149	893	5	4.0	19.0	149	893	5	4.0	19.0
	575	299	400	(2) 3/0-250	119	714	5	3.1	15.2	119	714	5	3.1	15.2
0210EC	460	393	600	(3) 2/0-400	163	893	5	4.0	19.0	149	893	5	4.0	19.0
	575	313	400	(2) 3/0-250	130	714	5	3.1	15.2	119	714	5	3.1	15.2
0230EC	460	407	600	(3) 2/0-400	163	893	5	4.0	19.0	163	893	5	4.0	19.0
	575	324	400	(2) 3/0-250	130	714	5	3.1	15.2	130	714	5	3.1	15.2

NOTE: Wye-Delta Compressor Start not available with this option.
See page 75 for Electrical Data footnotes.

Electrical Notes

LEGEND

ACR-LINE	ACROSS THE LINE START
C.B.	CIRCUIT BREAKER
D.E.	DUAL ELEMENT FUSE
DISC SW	DISCONNECT SWITCH
FACT CB	FACTORY-MOUNTED CIRCUIT BREAKER
FLA	FULL LOAD AMPS
HZ	HERTZ
MAX	MAXIMUM
MCA	MINIMUM CIRCUIT AMPACITY
MIN	MINIMUM
MIN NF	MINIMUM NON-FUSED
RLA	RUNNING LOAD AMPS
S.P. WIRE	SINGLE-POINT WIRING
Y-Δ	WYE-DELTA START
X-LRA	ACROSS-THE-LINE INRUSH LOCKED ROTOR AMPS
Y-LRA	WYE-DELTA INRUSH LOCKED ROTOR AMPS

VOLTAGE CODE

-17	= 200-3-60
-28	= 230-3-60
-40	= 380-3-60
-46	= 460-3-60
-58	= 575-3-60

Electrical Notes (Continued)

CONTROL POWER SUPPLY (UNITS WITHOUT STANDARD CONTROL CIRCUIT TRANSFORMER)

NO. OF COMPRESSORS	CONTROL POWER SUPPLY	MCA (MAX LOAD CURRENT)	MAX DUAL ELEMENT FUSE SIZE	NON-FUSED DISCONNECT SWITCH SIZE
2	115V-1Ø	20A	20A	30A
3 or 4 (Non-CE 50/60Hz)	115V-1Ø	30A	30A	30A

CONTROL POWER SUPPLY (UNITS WITH STANDARD CONTROL CIRCUIT TRANSFORMER)

NO. OF COMPRESSORS	CONTROL POWER SUPPLY	MCA (MAX LOAD CURRENT)	RECOMMENDED DUAL ELEMENT FUSE SIZE	NON-FUSED DISCONNECT SWITCH SIZE
2	200V - 60 HZ 230V - 60 HZ 380V - 60 HZ 460V - 60 HZ 575V - 60HZ	12.5A 10.9A 6.6A 5.4A 4.3A	30A 30A 15A 15A 15A	— — — — —
3 or 4	380V - 60 HZ 460V - 60 HZ 575V - 60 HZ	9.9A 8.2A 6.5A	30A 15A 15A	— — —

NOTES (for pages 66 - 74)

- Minimum circuit ampacity (MCA) is based on 125% of the rated load amps for the largest motor plus 100% of the rated load amps for all other loads included in the circuit, per N.E.C. Article 430-24. If a Factory Mounted Control Transformer is provided, add the following to the system #1 MCA values in the YCAS Tables: -17, add 15 amps; -28, add 12 amps; -40, add 7 amps; -46, add 6 amps; -58, add 5 amps.
- The recommended disconnect switch is based on a minimum of 115% of the summation rated load amps of all the loads included in the circuit, per N.E.C. 440 - 12A1.
- Minimum recommended fuse size is based on 150% of the largest motor RLA plus 100% of the remaining RLAs. Minimum fuse rating = (1.5 x largest compressor RLA) + other compressor RLAs + (# fans x each fan motor FLA).
- Maximum dual element fuse size is based on 225% maximum plus 100% of the rated load amps for all other loads included in the circuit, per N.E.C. 440-22. Maximum fuse rating = (2.25 x largest compressor RLA) + other compressor RLAs + (# fans x each fan motor FLA).
- Minimum recommended circuit breaker is 150% maximum plus 100% of rated load amps included in the circuit. Minimum circuit breaker rating = (1.5 x largest compressor RLA) + other compressor RLAs + (# fans x each fan motor FLA).
- Maximum circuit breaker is based on 225% maximum plus 100% of the rated load amps for all loads included in the circuit, per circuit, per U.L. 1995 Fig. 36.2. Maximum circuit breaker rating = (2.25 x largest compressor RLA) + other compressor RLAs + (# fans x each fan motor FLA).
- The Incoming Wire Range is the minimum and maximum wire size that can be accommodated by unit wiring lugs. The (1), (2), or (3) indicate the number of termination points or lugs which are available per phase. Actual wire size and number of wires per phase must be determined based on ampacity and job requirements using N.E.C. wire sizing information. The above recommendations are based on the National Electric Code and using **copper conductors** only. Field wiring must also comply with local codes.
- A ground lug is provided for each compressor system to accommodate field grounding conductor per N.E.C. Article 250-54. A control circuit grounding lug is also supplied. Incoming ground wire range is #6 - 350 MCM.
- The field supplied disconnect is a "Disconnecting Means" as defined in N.E.C. 100.B, and is intended for isolating the unit from the available power supply to perform maintenance and troubleshooting. This disconnect is not intended to be a Load Break Device.
- Two-Compressor machines with single-point power connection, and equipped with Star (Wye)-Delta Compressor motor start must also include factory-provided individual system circuit breakers in each motor control center. All 3 & 4 Compressor machines equipped with Star-Delta compressor motor start must also include factory-provided individual system circuit breakers in each motor control center.
- Consult factory for Electrical Data on units equipped with "High Static Fan" option. High Static Fans are 3.8 kW each.
- FLA for "Low Noise Fan" motors: 200V = 8.0A, 230V = 7.8A, 380V = 4.4A, 460V = 3.6A, 575V = 2.9A.
- Group Rated breaker must be HACR type for cUL Machines.

Power Connection Options

STYLE "F" 2 COMPRESSOR POWER WIRING CONNECTIONS

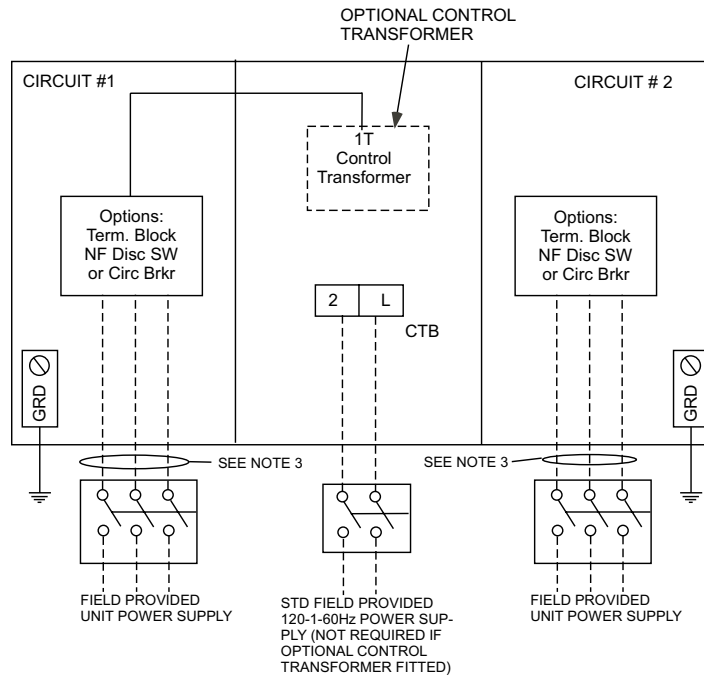

FIG. 1 – STYLE G 2 COMPRESSOR MULTIPLE POINT POWER SUPPLY CONNECTION

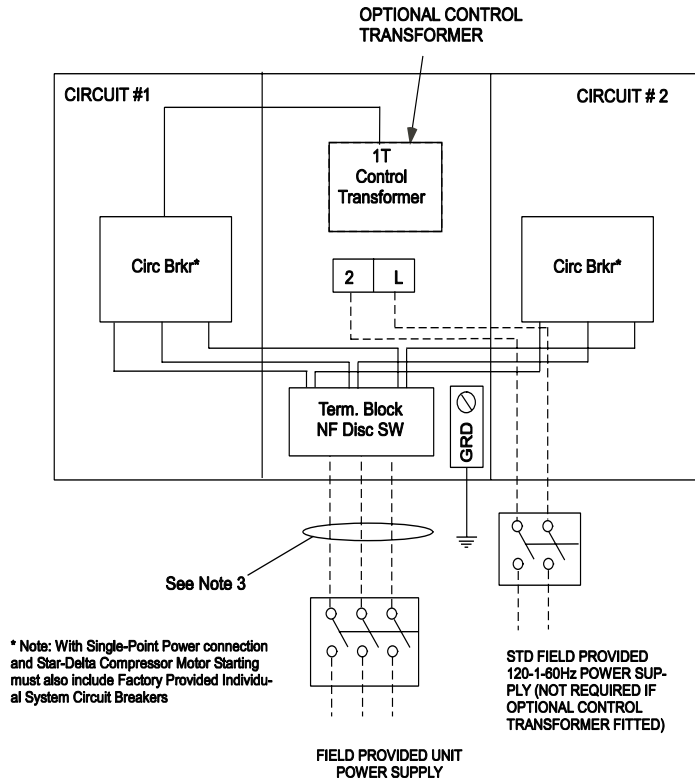

FIG. 2 – OPTIONAL SINGLE-POINT POWER SUPPLY WITH INDIVIDUAL SYSTEM CIRCUIT BREAKERS

STYLE "F" 2 COMPRESSOR POWER WIRING CONNECTIONS

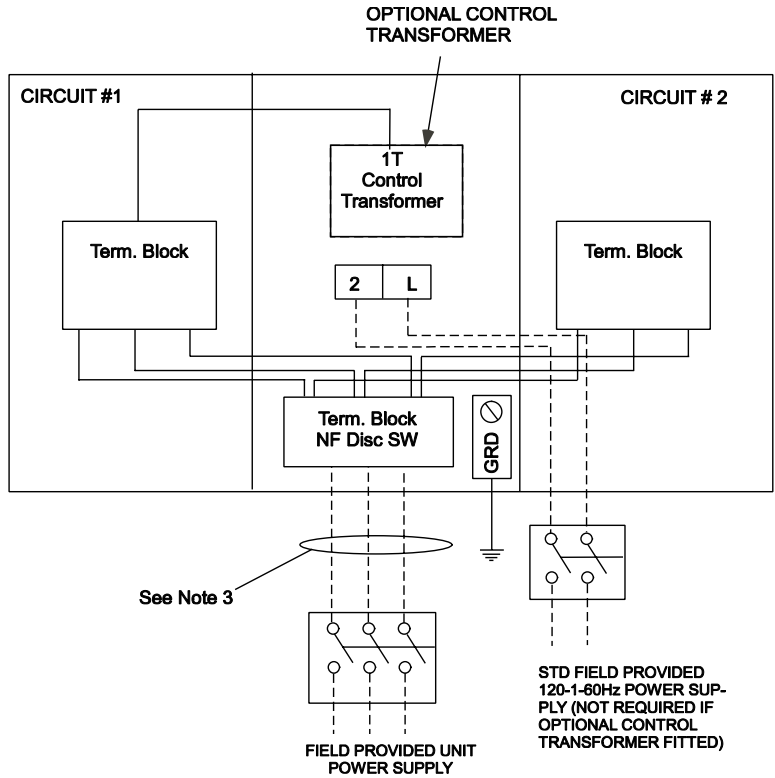

FIG. 3 – OPTIONAL SINGLE-POINT POWER SUPPLY CONNECTION WITH FIELD SUPPLIED CIRCUIT PROTECTION

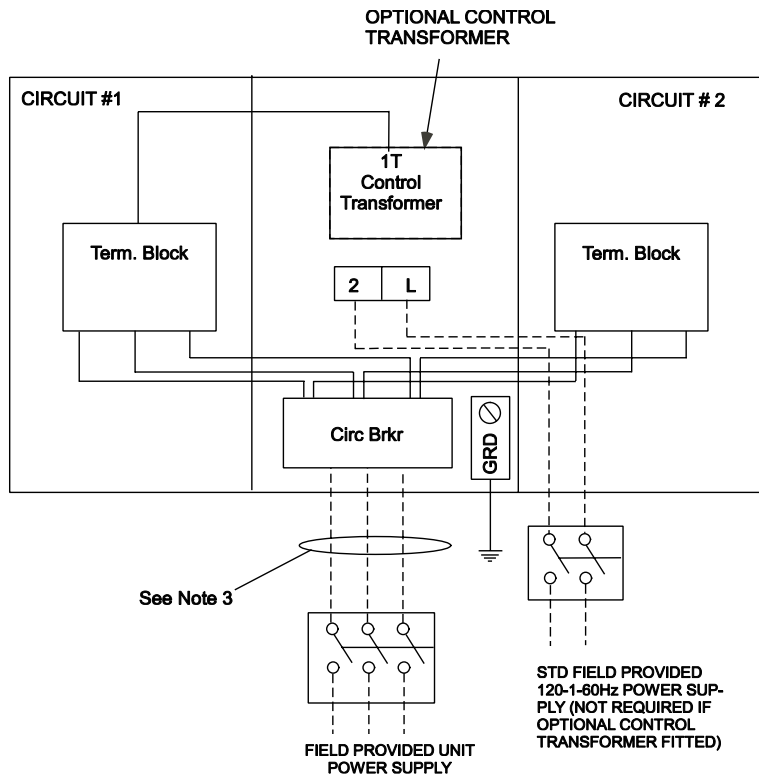
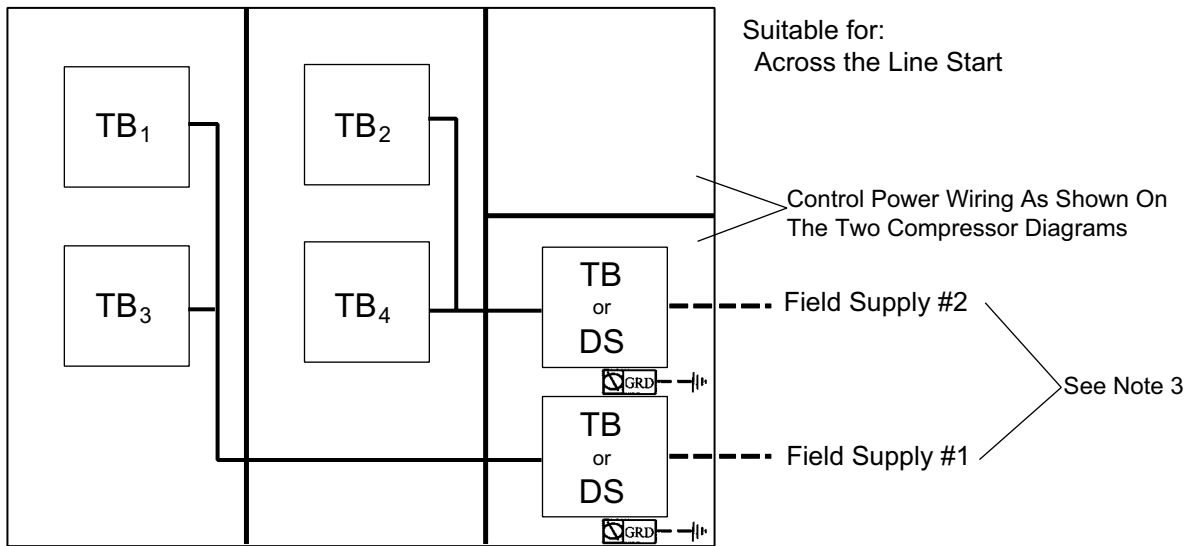

FIG. 4 – OPTIONAL SINGLE-POINT POWER SUPPLY WIRING TO FACTORY CIRCUIT BREAKER

Power Connection Options (Continued)

3 & 4 COMPRESSOR POWER CONNECTION OPTIONS



See page 79 for notes.

FIG. 5 – MULTIPLE POINT POWER SUPPLY CONNECTION

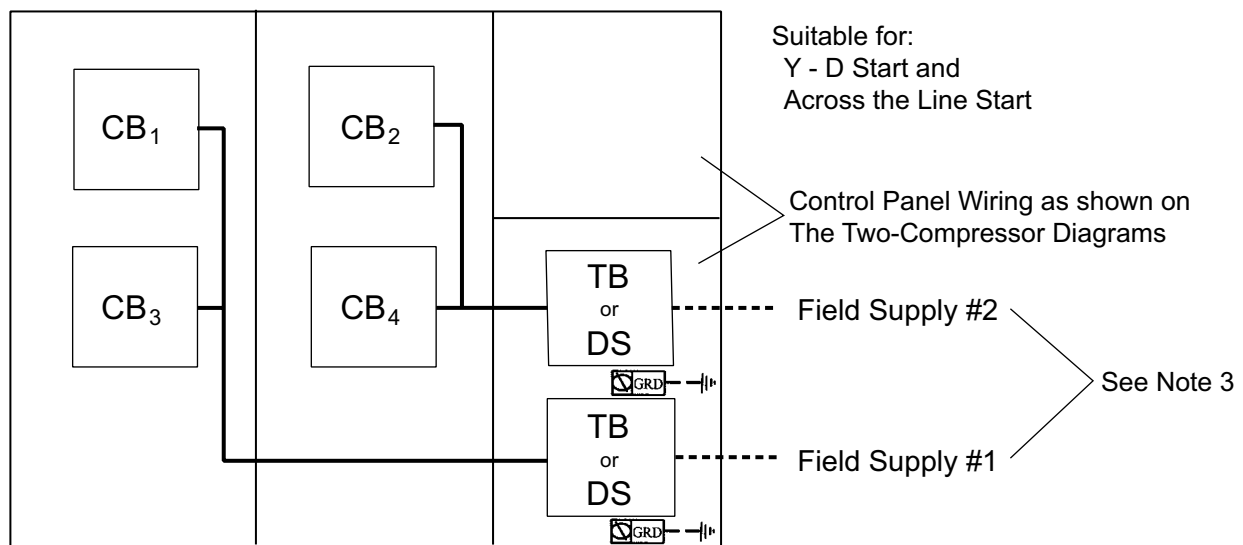

See page 79 for notes.

FIG. 6 – MULTIPLE POINT POWER SUPPLY CONNECTION WITH INDIVIDUAL SYSTEM CIRCUIT BREAKERS

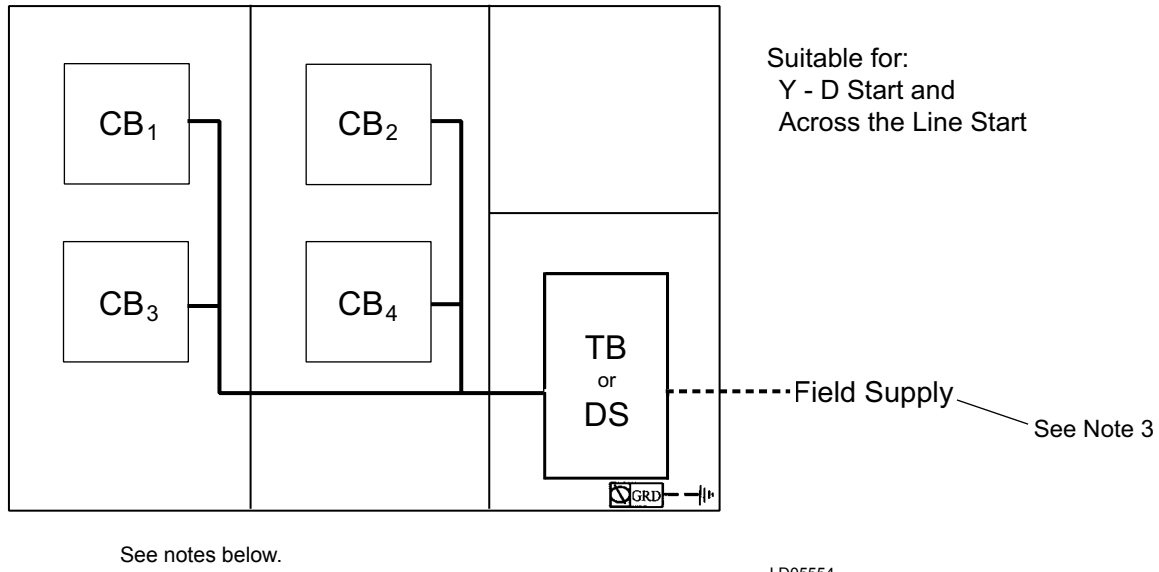

FIG. 7 – OPTIONAL SINGLE-POINT POWER SUPPLY CONNECTION WITH INDIVIDUAL SYSTEM CIRCUIT BREAKERS

NOTES:

1. U.L. Label is provided on 60 Hz units for these electrical wiring configurations.
2. — — — — — Dashed Line = Field Provided Wiring.
3. The above recommendations are based on the National Electric Code and using copper conductors only. Field wiring must also comply with local codes. Group Rated breaker must be HACR type for cUL machines.

LEGEND REFERS TO TYPICAL CONTROL WIRING DIAGRAM ON PAGES 80 & 81.

LEGEND

- TS** Transient Voltage Suppression
- ⬡ Terminal Block for Customer Connections
- ⬠ Terminal Block for Customer Low Voltage (Class 2) Connections. See Note 2
- Terminal Block for YORK Connections Only
- Wiring and Components by YORK
- ||— Optional Equipment
- — — Wiring and/or Components by Others

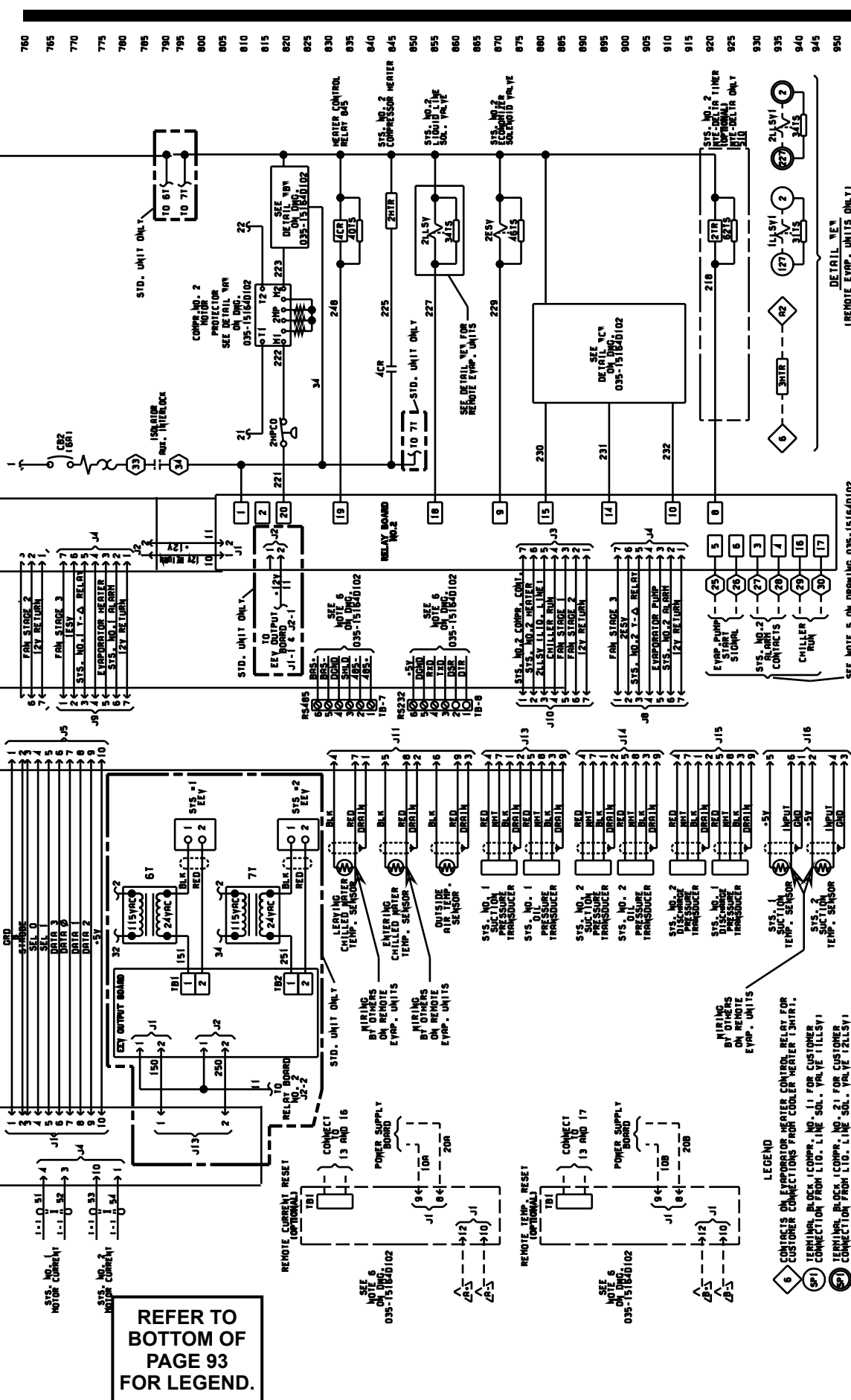

**REFER TO
BOTTOM OF
PAGE 93
FOR LEGEND.**

- NOTES:**
1. Field wiring to be in accordance with the current edition of the National Electrical Code as well as all other applicable codes and specifications.
 2. Contacts must be suitable for switching 24VDC. (gold contacts recommended). Wiring shall not be run in the same conduit with any line voltage wiring.
 3. To cycle unit on and off automatically with contact shown, install a cycling device in series with the flow switch (flsw). See note 2 for contact rating and wiring specifications.
 4. To stop unit (emergency stop) with contacts other than those shown, install the stop contact between terminals 5 and 1. If a stop device is not installed, a jumper must be connected between terminals 5 and 1. Device must have a minimum contact rating of 100va at 115 volts a.c.
 5. Alarm contacts are for annunciating alarm/unit malfunction. Contacts are rated at 115V, 100va, resistive load only, and must be suppressed at load by user.
 6. See Installation, Operation and Maintenance manual when optional equipment is used.

Application Data

UNIT LOCATION

The YCAS chillers are designed for outdoor installation. When selecting a site for installation, be guided by the following requirements:

1. Installation sites may be either on a roof or on ground level. (See FOUNDATION)
2. Select a place having an adequate supply of fresh air for the condensers. Recommended clearances for all units are shown on the DIMENSIONS pages.
3. Avoid locations near windows or structures where normal operating sounds may be objectionable.
4. The standard condenser fans are propeller-type and are not recommended for use with ductwork, filters or other nuisance in the condenser air stream.
5. When it is desirable to surround the unit(s), it is recommended that the screening be able to pass the required chiller CFM without exceeding 0.1" external static pressure.
6. Protection against corrosive environments is available by supplying the units with either copper fins, or cured epoxy-coating on the condenser coils. Epoxy-coated coils should be utilized with any units being installed at the seashore, or where salt spray may hit the units, or where acid rain is prevalent (copper condenser coils are not recommended where they may be exposed to acid rain).
7. On installations where winter operation is intended and snow accumulations are expected, additional elevation must be provided to insure normal condenser air flow.

FOUNDATION

The unit should be mounted on a flat and level foundation, ground or roof, capable of supporting the entire operating weight of the equipment. Operating weights are given in the PHYSICAL DATA tables.

Roof Locations – Adequate structural strength to safely support the entire weight of the unit and service personnel must be provided. Care must be taken not to damage the roof during installation. If the roof is “bonded”, consult building contractor or architect for special installation requirements. Roof installations should incorporate the use of spring-type isolators to minimize the transmission of vibration into building structure. Additional support should be provided to the

roof at the spring-isolator locations.

Ground Locations – Units must be installed on a substantial base that will not settle and cause strain on the refrigerant lines, resulting in possible leaks. A one-piece concrete slab, with footers extending below the frost line, is recommended. The slab should not be tied to the main building foundation as noises will telegraph.

Mounting holes (5/8") are provided in the base rails for bolting the unit to its foundation. See DIMENSIONS for location of the mounting holes.

For ground installations, precautions should be taken to protect the unit from tampering by, or injury to, unauthorized persons. Fasteners on access panels will prevent casual tampering; however, further safety precautions, such as unit enclosure options, a fenced-in enclosure, or locking devices on the panels may be advisable. Check local authorities for safety regulations.

CHILLED LIQUID PIPING

The chilled liquid piping system should be laid out so that the circulating pump discharges into the cooler. The inlet and outlet cooler-liquid connections are given in DIMENSIONS. Hand stop valves are recommended for use in all lines to facilitate servicing. Drain connections should be provided at all low points to permit complete drainage of the cooler and system piping.

A strainer (40 mesh) is recommended for use on the INLET line to the cooler, and must be in place at initial operation of the water pumps.

Pressure-gauge connections are recommended for installation in the inlet and outlet water lines. Gauges are not provided with the unit and are to be furnished by others.

Chilled liquid lines exposed to the weather should be wrapped with a supplemental heater cable and insulated, or glycol should be added to the chilled liquid to protect against freezing if low-ambient periods are expected.

A flow switch is available as an accessory on all units. A flow switch must be installed in the leaving water piping of the cooler and must not be used to start and stop the unit.

PART 1 — GENERAL

1.01 SCOPE

- A. The requirements of the General Conditions, Supplementary Conditions, Division 1, and Drawings apply to all Work herein.
- B. Provide Microprocessor controlled, twin-screw compressor, air-cooled, liquid chillers of the scheduled capacities as shown and indicated on the Drawings, including but not limited to:
 - 1. Chiller package
 - 2. Charge of refrigerant and oil
 - 3. Electrical power and control connections
 - 4. Chilled water connections

1.02 QUALITY ASSURANCE

- A. Products shall be Designed, Tested, Rated and Certified in accordance with, and installed in compliance with applicable sections of the following Standards and Codes:
 - 1. ANSI/ASHRAE Standard 15 – *Safety Code for Mechanical Refrigeration*
 - 2. ANSI/NFPA Standard 70 – *National Electrical Code (N.E.C.)*
 - 3. *ASME Boiler and Pressure Vessel Code, Section VIII, Division 1.*
 - 4. ARI Standard 550/590 – *Centrifugal and Rotary Screw Water Chilling Packages.*
 - 5. Conform to Underwriters Laboratories (U.L.) for construction of chillers and provide U.L./cU.L. Listing label.
 - 6. Manufactured in facility registered to ISO 9002.
- B. Factory Test: Chiller shall be pressure-tested, evacuated and fully charged with refrigerant and oil, and shall be factory operational run tested with water flowing through the vessel.
- C. Warranty: Manufacturer shall Warrant all equipment and material of its manufacture against defects in workmanship and material for a period of eighteen (18) months from date of initial start-up or date of shipment, whichever occurs first.

1.03 DELIVERY AND HANDLING

- A. Unit shall be delivered to job site fully assembled, and charged with refrigerant and oil by the Manufacturer.
- B. Unit shall be stored and handled per Manufacturer's instructions.

PART 2 — PRODUCTS

2.01 CHILLER MATERIALS AND COMPONENTS

- A. General: Install and commission, as shown on the schedules and plans, factory assembled, charged, and tested air cooled screw compressor chiller(s) as specified herein. Chiller shall be designed, selected, and constructed using a refrigerant with Flammability rating of "1", as defined by ANSI/ASHRAE STANDARD-34 *Number Designation and Safety Classification of Refrigerants*. Chiller shall include, but is not limited to: a complete system with not less than two independent refrigerant circuits, semihermetic twin screw compressors, direct expansion type evaporator, air-cooled condenser, refrigerant, lubrication system, interconnecting wiring, safety and operating controls including capacity controller, control center, motor starting components, and special features as specified herein or required for safe, automatic operation.
- B. Cabinet: External structural members shall be constructed of heavy gauge, galvanized steel coated with baked on powder paint which, when subject to ASTM B117, 500 hour, 5% salt spray test, yields minimum ASTM 1654 rating of "6".

2.02 COMPRESSORS AND MOTORS

- A. Compressors: Shall be direct drive, semihermetic, rotary twin-screw type, including: internal muffler, temperature actuated 'off-cycle' heater, rain-tight terminal box, internal discharge check, discharge and suction shut-off service valves, and precision machined cast iron housing. Design working pressure of entire compressor, suction to discharge, shall be 450 PSIG (31 bar). Compressor shall be U.L. listed.
- B. Motors: Refrigerant suction gas cooled two-pole accessible hermetic compressor motor, full suction gas flow through 0.006" maximum mesh screen, with inherent internal thermal overload protection and external current overload on all three phases. Motor stator shall employ APT2000 type magnet wire.
- C. Lubrication: External oil separators with no moving or fragile parts, 450 PSIG design working pressure, and UL listing. Refrigerant system differential pressure shall provide oil flow through service replaceable, 0.5 micron, full flow, cartridge type oil filter internal to compressor. Filter bypass, less restrictive media, or oil pump not acceptable.
- D. Capacity Control: Compressors shall start at minimum load position. Capacity control range from 100% to 10% of chiller full load using continuous function slide valves, and without hot gas bypass. Step unloading unacceptable. Provide Microprocessor controlled, output pressure regulating capacity control valve to

Guide Specifications (Continued)

command compressor capacity independent of control valve input pressure and balance compressor capacity with cooling load.

2.03 REFRIGERANT CIRCUIT COMPONENTS

Each independent refrigerant circuit shall include: liquid line shutoff valve with charging port, low side pressure relief device, removable core filter-drier, solenoid valve, sight glass with moisture indicator, and reliable electronic expansion valves for R22 and a thermostatic expansion valves for remote barrel units.

2.04 HEAT EXCHANGERS

A. Evaporator:

1. Direct expansion type with refrigerant inside high efficiency copper tubes, chilled liquid forced over the tubes by galvanized steel baffles. Independent refrigerant circuits per compressor.
2. Constructed, tested, and stamped in accordance with applicable sections of ASME pressure vessel code for minimum 350 PSIG (24 bar) refrigerant side design working pressure and 150 PSIG (10 bar) water side design working pressure.
3. Shell covered with $\frac{3}{4}$ " (19mm), flexible, closed-cell insulation, thermal conductivity of 0.26k ([BTU/HR-Ft²-°F]/in.) maximum. Water nozzles with grooves for mechanical couplings, and insulated by Contractor after pipe installation.
4. Provide vent and drain fittings, and thermostatically controlled heaters to protect to -20°F (-29°C) ambient in off-cycle.

B. Air Cooled Condenser:

1. Coils: Internally enhanced, seamless copper tubes, mechanically expanded into aluminum alloy fins with full height collars. Subcooling coil an integral part of condenser. Design working pressure shall be 450 PSIG (31 bar).
2. Fans: Shall be dynamically and statically balanced, direct drive, corrosion resistant glass fiber reinforced composite blades molded into low noise, full airfoil cross section, providing vertical air discharge from extended orifices for efficiency and low sound. Each fan in its own compartment to prevent cross flow during fan cycling. Guards of heavy gauge, PVC (polyvinyl chloride) coated or galvanized steel.
3. Fan Motors: High efficiency, direct drive, 6-pole, 3-phase, insulation class "F", current protected, Totally Enclosed Air-Over (TEAO), rigid mounted, with double sealed, permanently lubricated, ball bearings.

C. Refrigerant Economizer (when provided): Stainless steel plate type, oven brazed with copper, U.L./cU.L. Listed, 450 PSIG (31 bar) design working pressure.

2.05 CONTROLS

A. General: Automatic start, stop, operating, and protection sequences across the range of scheduled conditions and transients.

B. Control Circuit Transformer: Factory mounted with primary breaker having lockable, external handle, and 115V/1Ø secondary.

C. Microprocessor Enclosure: Rain and dust tight NEMA 3R/12 (IP55) powder painted steel cabinet with hinged, latched, and gasket sealed door.

D. Microprocessor Control Center:

1. Automatic control of compressor start/stop and load/unload, anti-coincidence and anti-recycle timers, automatic pump-down at start-up and shut-down, condenser fans, evaporator pump, evaporator heater, unit alarm contacts, run signal contacts, and chiller operation from 0°F to 125°F (-18°C to 52°) ambient. Automatic reset to normal chiller operation after power failure.
2. Setpoint Reset:
 - a. Pulse Width Modulated (PWM) input to reset current unload setpoint downward via signal from external Energy Management System (EMS), maximum allowable reset programmable from microprocessor keypad.
 - b. PWM input to reset the chilled liquid setpoint upward via signal from remote EMS, maximum allowable reset programmable from microprocessor keypad.
3. Software stored in non-volatile memory, with programmed setpoints retained in lithium battery backed real time clock (RTC) memory for minimum 5 years.
4. Forty character liquid crystal display, descriptions in English (or Spanish or French,), numeric data in English (or Metric) units. Sealed keypad with sections for Setpoints, Display, Entry, Print, Program, Clock, and Unit On/Off Switch.
5. Programmable Setpoints (within Manufacturer limits): display language; discharge pressure unload and cutout; low suction pressure cutout; low and high ambient cutouts; leaving chilled liquid temperature: setpoint, control range, and cutout; high motor current unload; anti-recycle time; lag compressor start; local or remote control; units of measure; compressor lead/lag; power failure restart (auto or manual), and maximum EMS-PWM reset temperature range.

6. Display Data: Chiller liquid return and leaving temperatures, ambient, lead compressor identification and lead/lag delay, clock and schedule, (variable) out of range, remote input indication, chilled liquid reset setpoint, leaving liquid pull-down rate setpoint, leaving liquid error (deviation from setpoint), and history data for last six shutdown faults. Compressor suction, discharge, and oil pressures and temperatures, suction and discharge superheats, percent of full-load motor current, operating hours, starts, and anti-recycle timer status. Status Messages for manual override, unit switch off, compressor run, run permissive, remote controlled shut down, no cooling load, daily/holiday shut down, anti-recycle/anti-coincident timer, high pressure low suction temperature limit.
 7. System Safeties: Shall cause individual compressor systems to perform auto-reset shut down; manual reset required after the third trip in 90 minutes. Includes: high discharge pressure or temperature, low suction pressure, high / low motor current, high pressure switch, high / low differential oil pressure, high oil temperature, and motor protector. Compressor motor protector shall protect against damage due to: low or high input current, phase reversal (reverse rotation), current unbalance, phase loss, thermal overload of windings, and low voltage.
 8. Unit Safeties: Shall be automatic reset and cause compressors to shut down if: high or low ambient, low leaving chilled liquid temperature, under voltage, and flow switch operation. Contractor shall provide flow switch and wiring per chiller manufacturer requirements.
 9. Alarm Contacts: High or low ambient, low leaving chilled liquid temperature, low voltage, low battery, and (per compressor circuit): high discharge pressure or temperature, low suction pressure, low or high motor current, low or high differential oil pressure, and high oil temperature.
- E. Manufacturer shall provide any controls not listed above, necessary for automatic chiller operation. Mechanical Contractor shall provide field control wiring necessary to interface sensors to the chiller control system.

2.06 POWER CONNECTION and DISTRIBUTION

A. Power Panels:

1. NEMA 3R/12 (IP55) rain/dust tight, powder painted steel cabinets with hinged, latched, and gasket sealed outer doors equipped with wind struts for safer servicing. Provide main power connection(s), compressor and fan motor start contactors, current overloads, and factory wiring.

ing.

2. Field power supply wiring connections shall be to a single power center on the chiller, shall be 3 phase of scheduled voltage, and shall connect to terminal blocks per each of the two motor control panels. Separate disconnecting means and/or external branch circuit protection (by Contractor) required per applicable local or national codes.
3. Provide two electrically separate, adjacent motor control center cabinets, with independent doors and separated by a steel panel, for compressor and fan motor power distribution components.

- B. Exposed compressor and fan motor power wiring shall be routed through liquid tight conduit.

2.07 ACCESSORIES and OPTIONS

Some accessories and options supercede standard product features. Your YORK representative will be pleased to provide assistance.

- A. Microprocessor controlled, Factory installed Wye-Delta compressor motor starters for reduced compressor inrush start current. Two-compressor machines with Single-Point Power connection and equipped with Star-Delta compressor motor start must also include factory provided circuit breakers in each motor control center. All 3 & 4 compressor machines equipped with Star-Delta compressor motor start must also include factory provided circuit breakers in each motor control center.

B. Power Supply Connections:

1. Two Compressor Machines –
 - a. Multiple Point with Individual System Circuit Breakers or Non-Fused Disconnect Switches: Two Field provided branch circuits shall connect to Individual System Circuit Breakers or Non-Fused Disconnects per compressor on each of the two motor control centers, with lockable external handles on doors in compliance with Article 440-14 of the N.E.C.
 - b. Single-Point Terminal Block or Non-fused Disconnect Switch: Field provided branch circuit shall connect to single-point Terminal Block or Non-Fused Disconnect with lockable external handle in compliance with N.E.C. Article 440-14, with Factory provided interconnecting wiring to (optional Individual System Circuit Breakers, and) compressor motor start components in each of two motor control center cabinets.
 - c. Single-Point Circuit Breaker: Field provided branch circuit shall connect to Single-Point Circuit Breaker with Lockable External Handle

Guide Specifications (Continued)

(in compliance with Article 440-14 of N.E.C.) factory provided interconnecting wiring to compressor motor start components in each of two motor control center cabinets.

2. Three and Four Compressor Machines –
 - a. Multiple Point power connection to Terminal Blocks or Non-Fused Disconnect Switches: Two Field provided branch circuits shall connect to factory provided Terminal Blocks or Non-Fused Disconnect Switches, with Lockable External Handle in compliance with Article 440-14 of N.E.C., with factory furnished interconnecting wiring to (optional Individual System Circuit Breakers with lockable external handles, and) compressor motor start components in each of the two motor control center cabinets.
 - b. Single-Point Terminal Block or Non-fused Disconnect Switch: Field provided branch circuit shall connect to Single-Point Terminal Block or Non-Fused Disconnect with lockable external handle in compliance with N.E.C. Article 440-14, with factory provided interconnecting wiring to Individual System Circuit Breakers and compressor motor start components in each of two motor control center cabinets.
- C. Control Power Terminal Strip: Provided in Microprocessor panel for field supplied 115V-1Ø control circuit power.
- D. Condenser Coil Environmental Protection:
 1. PRE-COATED FIN CONDENSER COILS – The air-cooled condenser coils are constructed of black epoxy-coated aluminum fins. This can provide corrosion resistance comparable to copper-fin coils in typical seashore locations. Either these or the post-coated coils (below), are recommended for units being installed at the seashore or where salt spray may hit the unit.
 2. COPPER FIN: Provide copper fins in lieu of aluminum.
 3. POST-COATED EPOXY DIPPED CONDENSER COILS – The unit is built with dipped-cured condenser coils. This is another choice for seashore and other corrosive applications (with the exception of strong alkalis, oxidizers and wet bromine, chlorine and fluorine in concentrations greater than 100 ppm).
- E. Protective Chiller Panels (Factory Mounted):
 1. Louvered Panels (condenser coils only): Painted steel as per remainder of unit cabinet, over external condenser coil faces.
 2. Wire Panels (full unit): Heavy gauge, welded wire-mesh, coated to resist corrosion, to protect condenser coils from incidental damage and restrict unauthorized access to internal components.
3. Louvered Panels (full unit): Painted steel as per remainder of unit cabinet, to protect condenser coils from incidental damage, visually screen internal components, and prevent unauthorized access to internal components.
4. Louvered/Wire Panels: Louvered steel panels on external condenser coil faces, painted as per remainder of unit cabinet. Heavy gauge, welded wire-mesh, coated to resist corrosion, around base of machine to restrict unauthorized access.
- F. Evaporator options:
 1. Provide 1-½" cooler insulation in lieu of standard ¾".
 2. Provide DX Cooler with 300 PSIG (20.7 bar) waterside design working pressure in lieu of standard 150 PSIG (10.3 bar).
 3. Provide Raised Face Flanges for cooler nozzles:
 - a. 150 PSIG (10.3 bar), welded flanges (field kit, mate supplied).
 - b. 300 PSIG (20.7 bar), welded flanges (factory installed, no mate supplied).
 - c. 150 PSIG (10.3 bar), Victaulic™ Flanges (field kit, no mate supplied).
- G. Remote Cooler: Manufacturer shall provide separately: 1. Chiller less evaporator, refrigerant, and liquid line mechanical devices; 2. Insulated evaporator; 3. Field accessory kit including filter-drier shell and core, liquid line solenoid valve, sight glass with moisture indicator, and expansion valve per refrigerant circuit; 4. Entering and leaving water temperature transducers. Contractor shall field erect system and provide interconnecting piping, refrigerant charge, and wiring in accordance with manufacturers recommendations, and project plans and schedules. Where not otherwise specified, Contractor provided system piping shall be in accordance with applicable sections of the ASHRAE Handbook.
- H. Flow Switch (Field Mounted): Vapor proof SPDT, NEMA 4X switch (___ 150 PSIG (10.3 bar) or ___ 300 PSIG (20.7 bar)), -20°F to 250°F (-28.9°C to 121.1°C).
- I. High External Static Pressure Fans and Motors: Factory installed fans and motors for up to 0.4 inches of water (100Pa) external static pressure at nominal condenser air flow.
- J. Microprocessor Membrane Keypad Graphics on in lieu of Standard English:
 1. French language.
 2. Spanish language.

- K. Thermal Storage: Leaving chilled liquid setpoint range for charge cycle from 25°F to 15°F (13.9°C to 8.3°C) minimum, automatic reset setpoint range of 40°F to 50°F (22.2°C to 27.8°C).
- L. Low Temperature Process Brine: Leaving chilled liquid setpoint range 20°F to 50°F (11.1°C to 27.8°C) [optional range of 15°F to 20°F (8.3°C to 11.1°C)].
- M. Building Automation System (EMS) Reset Interface: Chiller to accept 4 to 20mA, 0 to 10 VDC, or discrete contact closure input to reset the leaving chilled liquid temperature, or percent full load amps (current limit).
- N. Remote Control Panel (Field Mounted): Auxiliary panel for remote user interface for functions normally made at the unit control center
- O. Multi-Unit Sequence Control (Field Mounted): Separate Sequencing control center provided to permit control of up to eight chillers in parallel based on mixed liquid temperature.
- P. Sound Reduction:
1. Low speed, reduced noise fans (Factory Mounted)
 2. Acoustical compressor enclosures (Field Mounted)
 3. Compressor Sound Blankets (Factory Mounted)
- Q. Vibration Isolation (Field Mounted):
1. Neoprene Isolators.

2. 1 Inch Deflection Spring Isolators: Level adjustable, spring and cage type isolators for mounting under the unit base rails.
3. 2 Inch Deflection Seismic Isolators: Level adjustable, restrained mounts in rugged welded steel housing with vertical and horizontal limit stops. Housings shall be designed to withstand a minimum 1.0g accelerated force in all directions to 2" (50.8 mm).

PART 3 — EXECUTION

3.01 INSTALLATION

- A. General: Rig and Install in full accordance with Manufacturer's requirements, Project drawings, and Contract documents.
- B. Location: Locate chiller as indicated on drawings, including cleaning and service maintenance clearance per Manufacturer instructions. Adjust and level chiller on support structure.
- C. Components: Installing Contractor shall provide and install all auxiliary devices and accessories for fully operational chiller.
- D. Electrical: Coordinate electrical requirements and connections for all power feeds with Electrical Contractor (Division 16).
- E. Controls: Coordinate all control requirements and connections with Controls Contractor.
- F. Finish: Installing Contractor shall paint damaged and abraded factory finish with touch-up paint matching factory finish.

