

NEW FOR 2003



BELT DRIVE AIR HANDLING UNITS ENGINEERING GUIDE

**Models: YSHW, YSHX, YSVW
and YSVX**



00784VIP

MODEL YSHW, YSHX



00789VIP

MODEL YSVW, YSVX

Capacities from 800-8000 CFM



Table of Contents

Introduction	3
Product Description	4
Belt Drive Motor Data	5
Hydronic Unit Selection Procedure	6
Hydronic Unit Selection Component Static	7
Fan Performance (Hydronic)	8 - 9
Cooling Selection Hydronic (4 and 6 Row)	10-13
Heating Selection (2 and 4 Row)	14-17
Physical Data and Dimensions	18-21
24YSHW / 60 YSHW	18
90YSHW / 240 YSHW	19
24YSVW / 60YSVW	20
90YSVW / 240YSVW	21
DX Unit Selection Procedure	22
DX Component Static	23
Fan Performance (DX)	24 - 25
Cooling Selection (DX)	26 - 28
Heating Correction Factors	29
Heating Selection (2 Row only for DX)	30 - 31
Physical Data and Dimensions	32-35
24YSHX / 60YSHX	32
90YSHX / 240YSHX	33
24YSVX / 60YSVX	34
90YSVX / 240YSVX	35
Options HWK 2 Row and Plenum Box	36
Options (Mixing Box)	37
Guide Specifications	38
Notes:	39

Introduction

Introducing a new line of York air handling units! The air handler market of today demands the high-performance, flexibility, and quality available in this totally re-designed product.

CABINETS

Cabinets shall be manufactured of heavy gauge galvanized steel. The entire interior of the cabinet shall be insulated with one inch thick IAQ type insulation. Removable access panels shall be provided on both sides of the cabinet for maintenance and service. All cabinets shall have 2" supply and 1" return flanges.

INSULATION

The entire interior of the cabinet shall be insulated with RX insulation. This insulation must meet the requirements of ASTM C 1071, ASTM G 21, ASTM G 22, NFPA 90A, UL-181, and the cleaning practices of NAIMA.

MOTOR / BLOWERS

Blowers shall be resiliently mounted, with ball bearings, forward curved blade, and of centrifugal type. Each wheel shall be dynamically balanced for smooth, quiet operation. Blowers shall be belt driven with field adjustable pulleys to permit variations in static pressure and air requirements. Standard motors are 1725 RPM either single or three phase. All motors to be field or factory installed and wired at voltage specified by customer.

COILS

All **YSHW/YSVW** series coils shall consist of aluminum fins mechanically bonded onto 3/8" or 1/2" OD seamless copper tubing. All coils shall be leak tested at 350 PSIG minimum air pressure. Manual air vents shall be standard on all coils. Drain pans shall be coated for corrosion protection.

All **YSHX/YSVX** series coils shall consist of aluminum fins mechanically bonded onto 3/8" or 1/2" OD seamless copper tubing. All coils shall be leak tested at 350 PSIG minimum air pressure. 2 - 5 ton models shall feature a piston-type metering device approved for either straight cool or heat pump operation and be of single circuit design. 7 1/2 ton model shall be single circuited and have a factory installed expansion valve approved for straight cool only (not heat pump) operation. 10 - 20 ton models shall be dual-circuited and have factory installed expansion valves approved for straight cooling only (not heat pump) operation. Drain pans shall be coated for corrosion protection.

DRAIN PANS

Air handler shall have positive sloped drain pans for removal of condensate from the pan. Drain pans are to be coated with close cell foam insulation to provide protection from sweating and corrosion.

FILTERS

One inch throw away filters are standard in 2-5 ton **YSHX/YSVX** and **YSHW/YSVW** units. One inch permanent filters are provided as standard in 7 1/2-20 ton **YSHX/YSVX** and **YSHW/YSVW** units. Filters shall be accessible without tools.

LISTING

All standard units with thermal protected motors are ETL Listed. All air handlers shall be rated in accordance with ARI Standard 430.

Description

YORK BELT DRIVE UNITS

The York Belt Drive Units are designed for installation within the conditioned area or as remote units with duct systems. These air handlers are compact, with large removable panels for cooling and heating.

These commercial air handlers are designed to be installed in office buildings, hospitals, and any structure that requires high capacity and air volume.

YSHW



00784VIP

MODEL YSHW – Horizontal Hydronic Air Handler

The **YSHW** model air handler is constructed of sturdy galvanized steel. closed cell foam is used to coat the drain pan to prevent any sweating or corrosion. The **YSHW** fan motors are available in many voltages.

Options include mixing boxes permanent filters, discharge grills, etc.

YSHX



00790VIP

MODEL YSHX – DX or Heat Pump Horizontal Air Handler

The **YSHX** model air handler has all the characteristics of the **YSHW** with the addition of a DX or heat pump cooling coil.

Options include hot water coils, mixing boxes, expansion valves, discharge plenums and permanent filters.

YSVW



00789VIP

MODEL YSVW – Vertical Hydronic Air Handler

The **YSVW** air handler is constructed of sturdy galvanized steel. The air handlers are compact and have large, removable panels to facilitate service.

Options include mixing boxes, permanent filters and numerous fan motor voltages.

YSVX



00789VIP

MODEL YSVX – DX or Heat Pump Vertical Hydronic Air Handler

The **YSVX** air handler has all the characteristics of the **YSVW** with the addition of a DX or heat pump cooling coil. These air handlers are compact with larger removable panels to facilitate service.

Options include hot water coils, mixing boxes, expansion valves and permanent filters.

Belt Drive Motor Data

(Common to all YORK Belt Drive Units)

BELT DRIVE MOTOR DATA**					
HP.	VOLTAGE	PH.	HZ.	TOTAL AMPS*	RPM
1/4	115V	1	60	5.3	1725
1/4	277V	1	60	2.1	1725
1/4	115/208/230	1	60	5.0/2.6/2.5	1725
1/3	115V	1	60	6.7	1725
1/3	277V	1	60	2.6	1725
1/3	115/208/230	1	60	6.0/3.2/3.0	1725
1/3	208/230/460	3	60	1.8/1.6/.80	1725
1/2	115V	1	60	8.7	1725
1/2	277V	1	60	3.6	1725
1/2	115/208/230	1	60	8.4/4.4/4.2	1725
1/2	208/230/460	3	60	2.2/2.0/1.0	1725
3/4	115/208/230	1	60	13.2/7.3/6.6	1725
3/4	277V	1	60	5.1	1725
3/4	208/230/460	3	60	3.2/3.0/1.5	1725
1	115/208/230	1	60	16.0/8.8/8.0	1725
1	277V	1	60	5.4	1725
1	208/230/460	3	60	3.6/3.4/1.7	1725
1.5	115/208/230	1	60	18.4/10.2/9.2	1725
1.5	277V	1	60	8.5	1725
1.5	208/230/460	3	60	5.1/5.0/2.5	1725
2	115/208/230	1	60	24.6/13.6/12.3	1725
2	208/230/460	3	60	6.8/6.4/3.2	1725
3	230V ONLY	1	60	17	1725
3	208/230/460	3	60	9.6/9.2/4.6	1725
5	208/230/460	3	60	14.8/14.0/7.0	1725

*Actual Motor Amp Rating may vary slightly.

**Data subject to change without notice.

Hydronic Unit Selection



00784VIP

UNIT SELECTION PROCEDURE



00789VIP

INFORMATION REQUIRED FOR UNIT SELECTION

System Type (circle one) : 2 - pipe (1 coil) or 4 - pipe (sep. htg. & clg. coils)

CFM _____ E.S.P. _____ MOTOR: HP: _____ VOLTAGE: _____ PHASE: _____

COOLING: INDOOR: DB _____ WB _____ OUTDOOR: DB _____

TOTAL BTUH _____ SENS. BTUH _____ GPM _____ EWT _____

HEATING: TOTAL BTUH _____ GPM _____ EWT _____ EAT _____

MISC: _____

MECHANICAL SELECTION

1. In general, unit selection consists of choosing the correct model number that will provide the required BTUH cooling and / or heating capacity.

2. Select the unit model that meets the required total MBH cooling and heating at the required conditions from tables on pages 10-13 for cooling and 14-17 for heating (capacities and air are the same for YSHW and YSVW models). **NOTE:** In 4-pipe applications only 2-row heating available.

Example: Required clg. capacity = 48,000 BTUH clg. @ 45 degree EWT

Unit selected = 48YSHW4

3. To select unit RPM and horsepower, first determine the total static pressure which the unit must operate against. See chart on page 7 for individual component static resistances at various CFM values. For an application **with** duct work the total static consists of the sum of the external statics, e.g. duct and duct grilles, and the applicable blower coil unit component statics from page 7.

After total static pressure has been determined, see pages 8 and 9 to establish required fan RPM and motor HP.

Example: Determine required motor horsepower for a 48YSHW having a 4 row cooling coil, a 2 row heating coil, throwaway filter and .3 external static pressure. The unit is to deliver 1500 CFM.

Cabinet	.10
4 row coil (clg)	.20
2 row coil (htg)	.10
Filter	.06
External S.P. (*)	.30
	<u>.76</u>

(*) Unit without duct work, value is zero

From page 8 it is found that the above 48YSHW4 requires a 1/2 horsepower motor to deliver 1500 CFM against a total static pressure of .76.

Component Static - YSHW/YSVW

MODEL	NOMINAL CFM	COMPONENT STATIC RESISTANCE (INCHES OF WATER)				
		CABINET	COOLING COIL*		HEATING COIL	FILTER
			4 ROW	6 ROW	2 ROW	
24YSHW / 24YSVW	600	0.09	0.14	0.22	0.07	0.04
	700	0.10	0.18	0.27	0.09	0.05
	800	0.11	0.23	0.34	0.12	0.06
	900	0.12	0.28	0.42	0.14	0.07
	1000	0.13	0.33	0.50	0.18	0.08
36YSHW / 36YSVW	1000	0.09	0.17	0.25	0.08	0.04
	1100	0.10	0.19	0.28	0.10	0.05
	1200	0.11	0.23	0.34	0.12	0.06
	1300	0.12	0.26	0.39	0.13	0.07
	1400	0.13	0.30	0.45	0.15	0.08
48YSHW / 48YSVW	1400	0.09	0.18	0.27	0.09	0.05
	1500	0.10	0.20	0.31	0.10	0.06
	1600	0.11	0.23	0.34	0.11	0.06
	1700	0.12	0.25	0.38	0.12	0.07
	1800	0.13	0.28	0.42	0.13	0.08
60YSHW / 60YSVW	1800	0.10	0.20	0.28	0.09	0.05
	1900	0.11	0.21	0.31	0.10	0.06
	2000	0.12	0.23	0.34	0.11	0.06
	2100	0.13	0.25	0.37	0.12	0.07
	2200	0.15	0.28	0.40	0.13	0.08
90YSHW 90YSVW	2500	0.12	0.26	0.39	0.13	0.04
	2750	0.14	0.30	0.45	0.16	0.05
	3000	0.16	0.34	0.51	0.18	0.06
	3250	0.17	0.39	0.58	0.21	0.07
	3500	0.19	0.44	0.65	0.24	0.08
120YSHW / 120YSVW	3400	0.14	0.29	0.43	0.14	0.05
	3700	0.15	0.33	0.48	0.16	0.06
	4000	0.17	0.37	0.54	0.19	0.07
	4300	0.19	0.41	0.61	0.21	0.08
	4600	0.21	0.45	0.67	0.24	0.09
180YSHW / 180YSVW	5200	0.16	0.30	0.44	0.14	0.05
	5600	0.17	0.33	0.49	0.16	0.06
	6000	0.19	0.37	0.55	0.18	0.07
	6400	0.21	0.41	0.61	0.20	0.08
	6800	0.23	0.45	0.66	0.23	0.09
240YSHW / 240YSVW	6000	0.11	0.21	0.31	0.10	0.04
	7000	0.16	0.30	0.44	0.14	0.05
	8000	0.19	0.37	0.55	0.18	0.07
	9000	0.23	0.45	0.66	0.23	0.09
	10000	0.29	0.58	0.86	0.28	0.11

* Wet coil (dry coil p.d. = wet p.d. x .70)

Hydronic Fan Performance

2-5 TON FAN PERFORMANCE (YSHW AND YSVW)

MODEL	NOMINAL CFM	COIL FACE VELOCITY FPM	TOTAL STATIC PRESSURE - INCHES OF WATER									
			0.5		0.6		0.7		0.8		0.9	
			RPM	HP	RPM	HP	RPM	HP	RPM	HP	RPM	HP
24YSHW	600	300	770	1/6	840	1/6	900	1/6	990	1/4	1050	1/4
	700	350	780	1/6	850	1/6	910	1/4	990	1/4	1040	1/4
	800	400	800	1/4	860	1/4	910	1/4	990	1/4	1040	1/4
	900	450	810	1/4	880	1/4	925	1/4	1000	1/4	1050	1/3
24YSVW	1000	500	830	1/4	900	1/4	950	1/3	1000	1/3	1060	1/3
	1000	333	805	1/4	880	1/4	940	1/3	1000	1/3	1060	1/3
	1100	367	810	1/4	890	1/3	940	1/3	1000	1/3	1050	1/2
	1200	400	820	1/3	900	1/3	950	1/3	1005	1/2	1050	1/2
36YSHW	1300	434	840	1/3	905	1/3	960	1/3	1010	1/2	1060	1/2
	1400	466	870	1/3	920	1/3	980	1/2	1020	1/2	1090	1/2
	1400	350	720	1/3	775	1/3	825	1/3	870	1/2	910	1/2
	1500	375	740	1/3	785	1/2	830	1/2	875	1/2	920	1/2
48YSHW	1600	400	750	1/2	800	1/2	840	1/2	890	1/2	925	3/4
	1700	425	770	1/2	810	1/2	860	1/2	895	1/2	930	3/4
	1800	450	785	1/2	825	1/2	870	1/2	910	1/2	945	3/4
	1800	360	580	1/2	630	1/2	680	1/2	725	1/2	770	3/4
60YSHW	1900	380	580	1/2	630	1/2	680	1/2	725	1/2	775	3/4
	2000	400	590	1/2	635	1/2	680	1/2	730	1/2	770	3/4
	2100	420	600	1/2	640	1/2	690	1/2	730	3/4	770	3/4
	2200	440	600	1/2	645	1/2	690	1/2	735	3/4	775	3/4

7 1/2 -20 TON FAN PERFORMANCE (YSHW AND YSVW)

MODEL	NOMINAL CFM	COIL FACE VELOCITY FPM	TOTAL STATIC PRESSURE - INCHES OF WATER									
			0.6		0.7		0.8		0.9		1.0	
			RPM	HP	RPM	HP	RPM	HP	RPM	HP	RPM	HP
90YSHW	2500	333	580	1/2	600	3/4	640	3/4	690	3/4	710	3/4
	2750	366	580	1/2	605	3/4	640	3/4	690	3/4	710	3/4
	3000	400	580	3/4	610	3/4	640	3/4	680	3/4	710	1
90YSVW	3250	433	590	3/4	630	1	660	1	700	1	715	1
	3500	466	605	1	635	1	670	1	700	1	720	1
	3400	354	600	1	630	1	670	1	700	1	730	1-1/2
120YSHW	3700	385	610	1	650	1	680	1-1/2	705	1-1/2	740	1-1/2
	4000	417	630	1-1/2	670	1-1/2	695	1-1/2	710	1-1/2	750	1-1/2
	4300	448	650	1-1/2	685	1-1/2	705	1-1/2	730	1-1/2	770	2
120YSVW	4600	480	670	1-1/2	700	2	720	2	760	2	790	2
	5200	364	590	1-1/2	620	1-1/2	650	1-1/2	690	1-1/2	710	1-1/2
	5600	391	600	1-1/2	630	1-1/2	670	1-1/2	700	1-1/2	720	2
180YSHW	6000	420	610	1-1/2	640	1-1/2	680	1-1/2	700	2	730	2
	6400	447	625	2	660	2	690	2	710	2	740	3
	6800	475	640	2	680	2	700	3	720	3	760	3
240YSHW	6000	314	610	1-1/2	640	1-1/2	670	1-1/2	700	2	730	2
	7000	366	640	2	690	2	710	3	740	3	760	3
	8000	419	700	3	720	3	750	3	790	3	800	3
240YSVW	9000	470	730	5	760	5	800	5	810	5	830	5
	10000	500	800	5	820	5	840	5	880	5	900	5

NOTES:

- 1) Shaded area indicates the R.P.M. and C.F.M. range of the standard motor and pulleys.
- 2) Special pulleys and motors can be factory furnished at an additional charge.
- 3) Horsepower tabulated indicates minimum recommended motor H.P.
- 4) **Rated in accordance with ARI 430.**

Hydronic Fan Performance

2-5 TON FAN PERFORMANCE (YSHW AND YSVW)

NOMINAL CFM	COIL FACE VELOCITY FPM	TOTAL STATIC PRESSURE - INCHES OF WATER											
		1.0		1.2		1.4		1.6		1.8		2.0	
		RPM	HP	RPM	HP	RPM	HP	RPM	HP	RPM	HP	RPM	HP
600	300	1105	1/4	1210	1/3	1310	1/3	1420	1/3	1510	1/2	1600	<u>1/2</u>
700	350	1100	1/4	1200	1/3	1300	1/3	1405	1/2	1500	1/2	1590	<u>1/2</u>
800	400	1100	1/3	1195	1/3	1295	1/2	1395	1/2	1470	1/2	1580	<u>1/2</u>
900	450	1100	1/3	1190	1/3	1290	1/2	1390	1/2	1460	1/2	1540	3/4
1000	500	1110	1/3	1200	1/2	1295	1/2	1390	1/2	1450	3/4	1520	3/4
1000	333	1110	1/2	1230	1/2	<u>1335</u>	<u>1/2</u>	<u>1440</u>	<u>3/4</u>	<u>1540</u>	<u>3/4</u>	<u>1625</u>	<u>3/4</u>
1100	367	1110	1/2	1215	1/2	1325	1/2	<u>1425</u>	<u>3/4</u>	<u>1520</u>	<u>3/4</u>	<u>1615</u>	<u>3/4</u>
1200	400	1110	1/2	1210	1/2	1315	3/4	1415	3/4	<u>1500</u>	<u>3/4</u>	<u>1605</u>	<u>3/4</u>
1300	434	1110	1/2	1220	1/2	1315	3/4	1410	3/4	1490	3/4	---	---
1400	466	1120	1/2	1220	3/4	1320	3/4	1410	3/4	1500	3/4	---	---
1400	350	955	1/2	1050	3/4	1135	3/4	1215	3/4	<u>1300</u>	<u>1</u>	<u>1380</u>	<u>1</u>
1500	375	960	1/2	1050	3/4	1135	3/4	1210	3/4	1295	1	1370	1
1600	400	970	3/4	1050	3/4	1140	3/4	1210	3/4	1290	1	1360	1
1700	425	980	3/4	1065	3/4	1140	3/4	1210	1	1290	1	1350	1
1800	450	985	3/4	1070	3/4	1150	3/4	1215	1	1280	1	1350	1
1800	360	820	3/4	900	3/4	<u>975</u>	<u>3/4</u>	<u>1050</u>	<u>1</u>	<u>1125</u>	<u>1</u>	<u>1200</u>	<u>1-1/2</u>
1900	380	815	3/4	895	3/4	970	3/4	<u>1045</u>	<u>1</u>	<u>1120</u>	<u>1</u>	<u>1190</u>	<u>1-1/2</u>
2000	400	815	3/4	890	3/4	965	1	1040	1	<u>1110</u>	<u>1</u>	<u>1180</u>	<u>1-1/2</u>
2100	420	815	3/4	885	3/4	960	1	1035	1	1105	1-1/2	1175	1-1/2
2200	440	815	3/4	885	3/4	960	1	1030	1	1100	1-1/2	1165	1-1/2

7 1/2 -20 TON FAN PERFORMANCE (YSHW AND YSVW)

NOMINAL CFM	COIL FACE VELOCITY FPM	TOTAL STATIC PRESSURE - INCHES OF WATER									
		1.2		1.4		1.6		1.8		2.0	
		RPM	HP	RPM	HP	RPM	HP	RPM	HP	RPM	HP
2500	333	790	3/4	850	1	915	1-1/2	990	1-1/2	1030	1-1/2
2750	366	780	1	840	1	905	1-1/2	980	1-1/2	1020	1-1/2
3000	400	780	1	835	1-1/2	900	1-1/2	970	1-1/2	1010	1-1/2
3250	433	790	1-1/2	840	1-1/2	900	1-1/2	950	1-1/2	1005	2
3500	466	790	1-1/2	845	1-1/2	900	1-1/2	950	2	1005	2
3400	354	790	1-1/2	850	1-1/2	900	1-1/2	950	2	1005	2
3700	385	800	1-1/2	855	1-1/2	905	2	950	2	1005	2
4000	417	805	1-1/2	860	2	910	2	960	2	1005	3
4300	448	820	2	875	2	915	3	970	3	1010	3
4600	480	830	2	890	3	930	3	980	3	1015	3
5200	364	780	2	830	2	900	2	950	3	1000	3
5600	391	790	2	840	2	905	3	950	3	1000	3
6000	420	795	2	850	3	910	3	960	3	1000	3
6400	447	800	3	860	3	915	3	970	3	1000	5
6800	475	810	3	870	3	920	5	975	5	1005	5
6000	314	795	2	850	3	910	3	960	3	1000	3
7000	366	810	3	880	3	920	5	960	5	1000	5
8000	419	850	5	900	5	940	5	990	5	1020	5
9000	470	890	5	920	5	980	5	---	---	---	---
10000	500	---	---	---	---	---	---	---	---	---	---

Notes:

- 1) Special pulleys and motors can be factory furnished at an additional charge.
- 2) Horsepower tabulated indicates minimum recommended motor H.P.
- 3) **Rated in accordance with ARI 430.**

Hydronic Cooling Selection

24YSHW - 24YSVW CHILLED WATER COOLING CAPACITIES

ENT. WTR. °F	C.F.M.	24YSHW4 / 24YSVW4 (4 ROW COIL)									24YSHW6 / 24YSVW6 (6 ROW COIL)								
		G.P.M.	WTR. P.D. FT.	80°F DB/67°F WB ENT. AIR			75°F DB/63°F WB ENT. AIR			G.P.M.	WTR. P.D. FT.	80°F DB/67°F WB ENT. AIR			75°F DB/63°F WB ENT. AIR				
				TOTAL MBH	SENS. MBH	TEMP. RISE	TOTAL MBH	SENS. MBH	TEMP. RISE			TOTAL MBH	SENS. MBH	TEMP. RISE	TOTAL MBH	SENS. MBH	TEMP. RISE		
42	600	3.0	1.2	19.6	13.9	13.0	14.9	12.1	9.9	3.0	1.3	22.3	15.7	14.9	17.0	13.6	11.4		
	800			21.7	16.5	14.5	16.6	14.5	11.0			24.9	18.8	16.6	19.0	16.5	12.7		
	1000			23.2	18.7	15.5	17.7	16.6	11.8			26.7	21.6	17.8	20.4	19.1	13.6		
	45	600	6.0	4.4	24.8	15.9	8.3	18.9	13.7	6.3	5.0	3.3	26.9	17.5	10.8	20.6	15.0	8.2	
		800			29.0	19.2	9.7	22.2	16.7	7.4			31.3	21.2	12.5	24.0	18.4	9.6	
		1000			32.5	22.1	10.8	24.8	19.3	8.3			34.9	24.6	13.9	26.6	21.5	10.7	
		50	600	9.0	9.3	26.7	16.6	5.9	20.4	14.3	4.5	7.0	6.1	29.6	18.5	8.4	22.6	15.9	6.4
			800			31.8	20.3	7.1	24.3	17.6	5.4			35.2	22.8	10.0	26.9	19.6	7.7
			1000			36.3	23.6	8.1	27.7	20.4	6.2			39.8	26.5	11.4	30.4	23.0	8.7
45			600	3.0	1.2	17.9	13.3	12.0	13.7	11.6	9.1	3.0	1.3	20.5	14.9	13.7	15.6	13.1	10.4
			800			19.9	15.8	13.3	15.2	14.0	10.1			22.8	18.0	15.2	17.4	15.9	11.6
			1000			21.3	18.1	14.2	17.5	17.5	11.7			24.5	20.8	16.4	21.4	21.4	14.2
	50		600	6.0	4.4	22.7	15.1	7.6	17.4	13.1	5.8	5.0	3.3	24.7	16.6	9.9	18.9	14.3	7.5
			800			26.6	18.3	8.9	20.3	16.0	6.8			28.7	20.2	11.5	22.0	17.6	8.8
			1000			29.8	21.1	9.9	22.7	18.5	7.6			32.0	23.5	12.8	24.4	20.6	9.8
		50	600	9.0	9.3	24.5	15.8	5.4	18.7	13.6	4.2	7.0	6.1	27.1	17.5	7.7	20.7	15.1	5.9
			800			29.2	19.3	6.5	22.3	16.8	5.0			32.3	21.6	9.2	24.6	18.7	7.0
			1000			33.3	22.5	7.4	25.4	19.5	5.6			36.5	25.2	10.4	27.9	22.0	8.0
50			600	3.0	1.2	15.2	12.3	10.2	11.6	10.9	7.8	3.0	1.3	17.4	13.8	11.6	13.3	12.2	8.9
			800			16.9	14.8	11.3	12.8	12.8	8.6			19.4	16.8	12.9	15.6	15.6	10.4
			1000			18.1	17.0	12.1	14.6	14.6	9.7			20.9	19.5	13.9	17.8	17.8	11.9
	50		600	6.0	4.4	19.3	13.8	6.4	14.7	12.0	4.9	5.0	3.3	21.0	15.1	8.4	16.0	13.2	6.4
			800			22.6	16.8	7.5	17.3	14.8	5.8			24.4	18.6	9.8	18.7	16.3	7.5
			1000			25.3	19.5	8.4	19.3	17.2	6.4			27.2	21.7	10.9	20.8	19.2	8.3
		50	600	9.0	9.3	20.8	14.3	4.6	15.9	12.5	3.5	7.0	6.1	23.1	15.9	6.6	17.6	13.8	5.0
			800			24.8	17.6	5.5	19.0	15.5	4.2			27.4	19.7	7.8	20.9	17.2	6.0
			1000			28.3	20.6	6.3	21.6	18.1	4.8			31.1	23.2	8.9	23.7	20.3	6.8

36YSHW - 36YSVW CHILLED WATER COOLING CAPACITIES

ENT. WTR. °F	C.F.M.	36YSHW4 / 36YSVW4 (4 ROW COIL)									36YSHW6 / 36YSVW6 (6 ROW COIL)								
		G.P.M.	WTR. P.D. FT.	80°F DB/67°F WB ENT. AIR			75°F DB/63°F WB ENT. AIR			G.P.M.	WTR. P.D. FT.	80°F DB/67°F WB ENT. AIR			75°F DB/63°F WB ENT. AIR				
				TOTAL MBH	SENS. MBH	TEMP. RISE	TOTAL MBH	SENS. MBH	TEMP. RISE			TOTAL MBH	SENS. MBH	TEMP. RISE	TOTAL MBH	SENS. MBH	TEMP. RISE		
42	1000	4.0	2.0	29.6	21.9	14.8	22.6	19.2	11.3	4.0	2.7	35.6	25.4	17.8	27.2	22.1	13.6		
	1200			31.4	24.4	15.7	24.0	21.5	12.0			38.0	28.5	19.0	29.1	25.0	14.5		
	1400			33.1	26.7	16.6	25.3	23.7	12.7			40.5	31.5	20.2	30.9	27.7	15.5		
	45	1000	8.0	7.5	39.0	25.4	9.8	29.8	22.0	7.4	7.0	7.5	45.0	29.0	12.9	34.4	25.0	9.8	
		1200			43.0	28.7	10.7	32.8	24.9	8.2			49.7	33.0	14.2	38.0	28.5	10.8	
		1400			46.5	31.6	11.6	35.5	27.6	8.9			53.9	36.6	15.4	41.2	31.8	11.8	
		50	600	12.0	16.3	42.6	26.8	7.1	32.5	23.1	5.4	10.0	14.5	49.5	31.0	9.9	37.8	26.5	7.6
			800			47.5	30.4	7.9	36.3	26.3	6.0			55.5	35.3	11.1	42.4	30.3	8.5
			1000			52.0	33.7	8.7	39.7	29.2	6.6			60.9	39.3	12.2	46.5	33.9	9.3
45			1000	4.0	2.0	27.2	21.0	13.6	21.7	18.5	10.4	4.0	2.7	32.6	24.2	16.3	24.9	21.3	12.5
			1200			28.8	23.4	14.4	22.0	20.7	11.0			34.9	27.3	17.4	26.7	24.0	13.3
			1400			30.4	25.8	15.2	25.0	25.0	12.5			37.1	30.3	18.6	28.4	26.8	14.2
	50		1000	8.0	7.5	35.8	24.2	8.9	27.3	21.0	6.8	7.0	7.5	41.3	27.6	11.8	31.5	23.9	9.0
			1200			39.4	27.3	9.9	30.1	23.9	7.5			45.6	31.3	13.0	34.8	27.2	10.0
			1400			42.6	30.2	10.7	32.6	26.4	8.1			49.5	34.9	14.1	37.8	30.4	10.8
		50	600	12.0	16.3	39.0	25.5	6.5	29.8	22.0	5.0	10.0	14.5	45.4	29.2	9.1	34.7	25.2	6.9
			800			43.6	28.9	7.3	33.3	25.1	5.5			50.9	33.4	10.2	38.9	28.9	7.8
			1000			47.7	32.1	7.9	36.4	27.9	6.1			55.9	37.3	11.2	42.7	32.3	8.5
50			1000	4.0	2.0	23.1	19.5	11.5	17.2	17.2	8.6	4.0	2.7	27.7	22.4	13.9	21.2	19.8	10.6
			1200			24.5	21.9	12.2	19.1	19.1	9.5			29.7	25.4	14.8	23.6	23.6	11.8
			1400			25.8	24.2	12.9	20.8	20.8	10.4			31.6	28.3	15.8	26.0	26.0	13.0
	50		1000	8.0	7.5	30.4	22.2	7.6	23.2	19.4	5.8	7.0	7.5	35.1	25.2	10.0	26.8	22.0	7.7
			1200			33.5	25.1	8.4	25.6	22.1	6.4			38.8	28.7	11.1	29.6	25.2	8.5
			1400			36.2	27.9	9.1	27.7	24.6	6.9			42.1	32.1	12.0	32.1	28.2	9.2
		50	600	12.0	16.3	33.2	23.2	5.5	25.3	20.3	4.2	10.0	14.5	38.6	26.5	7.7	29.5	23.1	5.9
			800			37.1	26.4	6.2	28.3	23.2	4.7			43.3	30.4	8.7	33.0	26.5	6.6
			1000			40.5	29.4	6.8	31.0	25.8	5.2			47.5	34.1	9.5	36.3	29.8	7.3

Hydronic Cooling Selection

48YSHW - 48YSVW CHILLED WATER COOLING CAPACITIES

ENT. WTR. °F	CFM	48YSHW4 / 48YSVW4 (4 ROW COIL)									48YSHW6 / 48YSVW6 (6 ROW COIL)								
		GPM	WTR. P.D. FT.	80°F DB/67°F WB ENT. AIR			75°F DB/63°F WB ENT. AIR			GPM	WTR. P.D. FT.	80°F DB/67°F WB ENT. AIR			75°F DB/63°F WB ENT. AIR				
				TOTAL MBH	SENS. MBH	TEMP. RISE	TOTAL MBH	SENS. MBH	TEMP. RISE			TOTAL MBH	SENS. MBH	TEMP. RISE	TOTAL MBH	SENS. MBH	TEMP. RISE		
42	1400	6.0	3.9	42.9	31.0	14.3	32.8	27.2	10.9	5.0	2.3	45.6	33.8	18.2	34.8	29.6	13.9		
	1600			45.1	33.6	15.0	34.5	29.6	11.5			47.5	36.7	19.0	36.3	32.3	14.5		
	1800			46.5	35.9	15.5	35.5	31.6	11.8			48.7	39.3	19.5	37.2	34.7	14.9		
	45	1400	10.0	10.3	52.6	34.7	10.5	40.2	30.1	8.0	8.0	5.5	57.0	38.2	14.2	43.5	33.1	10.9	
		1600			56.4	37.9	11.3	43.1	32.9	8.6			60.7	41.7	15.2	46.3	36.2	11.6	
		1800			59.7	40.7	11.9	45.6	35.5	9.1			63.7	44.9	15.9	48.7	39.2	12.2	
		50	1400	13.0	17.0	56.3	36.1	8.7	43.0	31.2	6.6	11.0	10.1	63.6	40.9	11.6	48.6	35.2	8.8
			1600			60.8	39.6	9.4	46.5	34.3	7.1			68.6	44.8	12.5	52.4	38.7	9.5
			1800			65.0	42.8	10.0	49.6	37.1	7.6			73.1	48.5	13.3	55.8	42.0	10.1
45			1400	6.0	3.9	39.4	29.7	13.1	30.1	26.1	10.0	5.0	2.3	41.8	32.4	16.7	31.9	28.5	12.8
			1600			41.4	32.3	13.8	31.6	28.5	10.5			43.6	35.3	17.4	33.3	31.2	13.3
			1800			42.6	34.5	14.2	32.6	30.5	10.9			44.7	37.8	17.9	39.6	39.6	15.8
	50		1400	10.0	10.3	48.3	33.0	9.7	36.9	28.8	7.4	8.0	5.5	52.3	36.4	13.1	39.9	31.7	10.0
			1600			51.8	26.1	10.4	39.5	31.5	7.9			55.7	39.8	13.9	42.5	34.7	10.6
			1800			54.7	38.9	10.9	41.8	34.1	8.4			58.4	42.9	14.6	44.6	37.6	11.2
		50	1400	13.0	17.0	51.6	34.3	7.9	39.4	29.8	6.1	11.0	10.1	58.4	38.8	10.6	44.6	33.5	8.1
			1600			55.8	37.6	8.6	42.6	32.7	6.6			63.0	42.6	11.4	48.1	36.9	8.7
			1800			59.6	40.7	9.2	45.5	35.5	7.0			67.0	46.2	12.2	51.2	40.2	9.3
50			1400	6.0	3.9	33.5	27.6	11.2	24.2	24.2	8.1	5.0	2.3	35.5	30.2	14.2	28.4	28.4	11.4
			1600			35.2	30.1	11.7	26.1	26.1	8.7			37.1	32.9	14.8	30.7	30.7	12.3
			1800			36.2	32.2	12.1	28.0	28.0	9.3			38.0	35.5	15.2	33.0	33.0	13.2
	50		1400	10.0	10.3	41.0	30.3	8.2	31.3	26.6	6.3	8.0	5.5	44.4	33.4	11.1	33.9	29.3	8.5
			1600			44.0	33.2	8.8	33.6	29.3	6.7			47.3	36.6	11.8	36.1	32.3	9.0
			1800			46.5	35.9	9.3	35.5	31.7	7.1			49.7	39.7	12.4	37.9	35.0	9.5
		50	1400	13.0	17.0	43.9	31.4	6.8	33.5	27.5	5.2	11.0	10.1	49.6	35.4	9.0	37.9	30.9	6.9
			1600			47.4	34.5	7.3	36.2	30.3	5.6			53.5	39.0	11.8	40.9	34.1	7.4
			1800			50.7	37.4	7.8	38.7	32.9	6.0			57.0	42.4	10.4	43.5	37.2	7.9

60YSHW - 60YSVW CHILLED WATER COOLING CAPACITIES

ENT. WTR. °F	CFM	60YSHW4 / 60YSVW4 (4 ROW COIL)									60YSHW6 / 60YSVW6 (6 ROW COIL)								
		GPM	WTR. P.D. FT.	80°F DB/67°F WB ENT. AIR			75°F DB/63°F WB ENT. AIR			GPM	WTR. P.D. FT.	80°F DB/67°F WB ENT. AIR			75°F DB/63°F WB ENT. AIR				
				TOTAL MBH	SENS. MBH	TEMP. RISE	TOTAL MBH	SENS. MBH	TEMP. RISE			TOTAL MBH	SENS. MBH	TEMP. RISE	TOTAL MBH	SENS. MBH	TEMP. RISE		
42	1800	6.0	1.8	48.7	37.4	16.2	37.2	33.0	12.4	6.0	1.6	57.5	43.0	19.2	43.9	37.7	14.6		
	2000			49.0	39.3	16.3	37.4	34.8	12.5			57.8	45.3	19.3	44.2	39.9	14.7		
	2200			49.6	41.3	16.5	43.1	43.1	14.4			58.8	47.8	19.6	44.9	42.3	15.0		
	45	1800	11.0	5.7	63.6	43.0	11.6	48.6	37.4	8.8	9.0	3.4	69.6	47.6	15.5	53.2	41.4	11.8	
		2000			66.7	45.9	12.1	50.9	40.0	9.3			72.1	50.7	16.0	55.1	44.2	12.2	
		2200			69.4	48.5	12.6	53.0	42.4	9.6			74.6	53.7	16.6	57.0	46.9	12.7	
		50	1800	16.0	11.6	70.6	45.7	8.8	53.9	39.5	6.7	12.0	5.9	77.3	50.7	12.9	59.1	43.8	9.8
			2000			75.3	49.1	9.4	57.5	42.6	7.2			81.5	54.3	13.6	62.3	47.0	10.4
			2200			79.4	52.3	9.9	60.6	45.4	7.6			85.4	57.8	14.2	65.2	50.2	10.9
45			1800	6.0	1.8	44.7	35.9	14.9	34.1	31.8	11.4	6.0	1.6	52.7	41.2	17.6	40.3	36.3	13.4
			2000			45.0	37.9	15.0	37.1	37.1	12.4			53.1	43.6	17.7	40.5	38.5	13.5
			2200			45.5	39.9	15.2	39.2	39.2	13.1			53.9	46.0	18.0	48.3	48.3	16.1
	50		1800	11.0	5.7	58.4	41.0	10.6	44.6	35.8	8.1	9.0	3.4	63.8	45.4	14.2	48.8	39.6	10.8
			2000			61.2	43.8	11.1	46.7	38.4	8.5			66.2	48.4	14.7	50.5	42.4	11.2
			2200			63.7	46.4	11.6	48.6	40.7	8.8			68.5	51.4	15.2	52.3	45.1	11.6
		50	1800	16.0	11.6	64.8	43.4	8.1	49.5	37.7	6.2	12.0	5.9	71.0	48.2	11.8	54.2	41.8	9.0
			2000			69.1	46.7	8.6	52.7	40.7	6.6			74.8	51.7	12.5	57.1	45.0	9.5
			2200			72.9	49.8	9.1	55.6	43.5	7.0			78.3	55.1	13.1	59.8	48.0	10.0
50			1800	6.0	1.8	38.0	33.6	12.7	29.1	29.1	9.7	6.0	1.6	44.8	38.3	14.9	35.5	35.5	11.8
			2000			38.2	35.5	12.7	31.0	31.0	10.3			45.1	40.7	15.0	38.0	38.0	12.7
			2200			39.2	39.2	13.1	32.7	32.7	10.9			45.8	43.2	15.3	40.2	40.2	13.4
	50		1800	11.0	5.7	49.6	37.7	9.0	37.9	33.2	6.9	9.0	3.4	54.3	41.8	12.1	41.4	36.8	9.2
			2000			52.0	40.4	9.5	39.7	35.7	7.2			56.2	44.7	12.5	43.0	39.5	9.5
			2200			54.1	42.9	9.8	41.3	38.0	7.5			58.2	47.6	12.9	44.5	42.1	9.9
		50	1800	16.0	11.6	55.1	39.7	6.9	42.1	34.8	5.3	12.0	5.9	60.3	44.1	10.1	46.1	38.6	7.7
			2000			58.7	42.9	7.3	44.8	37.6	5.6			63.6	47.4	10.6	48.6	41.6	8.1
			2200			61.9	45.8	7.7	47.3	40.2	5.9			66.6	50.7	11.1	50.9	44.5	8.5

Hydronic Cooling Selection

90YSHW - 90YSVW CHILLED WATER COOLING CAPACITIES

ENT. WTR. °F	CFM	90YSHW4 / 90YSVW4 (4 ROW COIL)									90YSHW6 / 90YSVW6 (6 ROW COIL)								
		GPM	WTR. P.D. FT.	80°F DB/67°F WB ENT. AIR			75°F DB/63°F WB ENT. AIR			GPM	WTR. P.D. FT.	80°F DB/67°F WB ENT. AIR			75°F DB/63°F WB ENT. AIR				
				TOTAL MBH	SENS. MBH	TEMP. RISE	TOTAL MBH	SENS. MBH	TEMP. RISE			TOTAL MBH	SENS. MBH	TEMP. RISE	TOTAL MBH	SENS. MBH	TEMP. RISE		
42	2500	10.0	2.2	80.4	60.2	16.1	61.4	52.8	12.3	11	1.6	94.2	66.6	17.1	71.9	58.0	13.1		
	3000			85.2	67.6	17.0	65.0	59.6	13.0			100.3	74.9	18.2	76.6	65.6	13.9		
	3500			89.4	74.7	17.9	76.5	67.5	15.3			106.6	83.3	19.4	81.4	73.3	14.8		
	45	2500	15.0	4.7	96.3	66.3	12.8	73.5	57.6	9.8	21	5.5	120.7	77.2	11.5	92.2	66.3	8.8	
		3000			104.5	74.8	13.9	79.8	65.3	10.6			133.4	87.8	12.7	101.9	75.8	9.7	
		3500			111.2	82.7	14.8	84.9	72.5	11.3			144.9	98.0	13.8	110.1	84.8	10.5	
		50	2500	22.0	9.8	108.1	71.0	9.8	82.6	61.3	7.5	31	11.5	133.3	82.4	8.6	101.8	70.3	6.6
			3000			119.3	80.6	10.8	91.1	69.8	8.3			149.6	94.4	9.6	114.2	80.9	7.4
			3500			128.8	89.4	11.7	98.3	77.8	8.9			164.1	105.7	10.6	125.3	90.9	8.1
42			2500	10.0	2.2	73.8	57.8	14.8	56.3	50.9	11.3	11	1.6	86.4	63.6	15.7	66.0	55.7	12.0
			3000			78.1	65.0	15.6	63.4	63.4	12.7			92.0	71.8	16.7	70.3	63.2	12.8
			3500			82.0	72.0	16.4	69.6	69.6	13.9			97.8	80.0	17.8	74.7	70.7	13.6
	45		2500	15.0	4.7	88.3	63.3	11.8	67.5	55.2	9.0	21	5.5	110.8	73.2	10.6	84.6	63.1	8.1
			3000			95.8	71.6	12.8	73.2	62.8	9.8			122.4	83.4	11.7	93.5	72.3	8.9
			3500			102.0	79.3	13.6	77.9	69.8	10.4			132.9	93.3	12.7	101.5	81.2	9.7
		50	2500	22.0	9.8	99.2	67.5	9.0	75.8	58.5	6.9	31	11.5	122.3	77.8	7.9	93.4	66.7	6.0
			3000			109.4	76.7	9.9	83.6	66.8	7.6			137.2	89.4	8.9	104.8	76.9	6.8
			3500			118.1	85.3	10.7	90.2	74.6	8.2			150.6	100.2	9.7	115.0	86.6	7.4
42			2500	10.0	2.2	62.7	53.7	12.5	47.2	47.2	9.4	11	1.6	73.5	58.8	13.4	56.1	51.8	10.2
			3000			66.4	60.8	13.3	52.8	52.8	10.6			78.2	66.7	14.2	62.5	62.5	11.4
			3500			69.6	69.6	13.9	58.0	58.0	11.6			83.1	74.7	15.1	68.5	68.5	12.5
	45		2500	15.0	4.7	75.1	58.3	10.0	57.4	51.3	7.6	21	5.5	94.2	66.6	9.0	71.9	58.0	6.8
			3000			81.5	66.2	10.9	62.2	58.5	8.3			104.1	76.3	9.9	79.5	66.7	7.6
			3500			86.7	73.7	11.6	63.3	63.3	8.4			113.0	85.7	10.8	86.3	75.2	8.2
		50	2500	22.0	9.8	84.3	61.7	7.7	64.4	54.0	5.9	31	11.5	103.9	70.4	6.7	79.4	61.0	5.1
			3000			93.0	70.5	8.5	71.0	61.9	6.5			116.6	81.2	7.5	89.1	70.6	5.7
			3500			100.4	78.7	9.1	76.7	69.3	7.0			128.0	91.4	8.3	97.7	79.7	6.3

120YSHW - 120YSVW CHILLED WATER COOLING CAPACITIES

ENT. WTR. °F	CFM	120YSHW4 / 120YSVW4 (4 ROW COIL)									120YSHW6 / 120YSVW6 (6 ROW COIL)								
		GPM	WTR. P.D. FT.	80°F DB/67°F WB ENT. AIR			75°F DB/63°F WB ENT. AIR			GPM	WTR. P.D. FT.	80°F DB/67°F WB ENT. AIR			75°F DB/63°F WB ENT. AIR				
				TOTAL MBH	SENS. MBH	TEMP. RISE	TOTAL MBH	SENS. MBH	TEMP. RISE			TOTAL MBH	SENS. MBH	TEMP. RISE	TOTAL MBH	SENS. MBH	TEMP. RISE		
42	3400	12.0	2.0	104.7	80.0	17.4	79.9	70.3	13.3	15.0	1.7	130.7	91.5	17.4	99.8	79.6	13.3		
	4000			107.3	87.7	17.9	82.0	77.5	13.7			136.7	100.9	18.2	104.4	88.3	13.9		
	4600			111.7	95.9	18.6	85.5	81.5	14.4			143.5	110.7	19.1	109.6	97.3	14.6		
	45	3400	21.0	5.8	132.7	90.7	12.6	101.3	78.7	9.7	25.0	4.7	158.3	102.5	12.7	120.9	88.2	9.7	
		4000			142.6	100.9	13.6	108.9	88.0	10.4			172.3	114.8	13.8	131.6	99.2	10.5	
		4600			151.4	110.5	14.4	115.7	96.7	11.0			184.8	126.5	14.8	141.2	109.8	11.3	
		50	3400	30.0	11.4	145.5	95.8	9.7	111.1	82.7	7.4	35.0	9.1	173.2	108.7	9.9	132.3	92.9	7.6
			4000			159.4	107.4	10.6	121.8	93.1	8.1			192.0	122.8	11.0	146.6	105.4	8.4
			4600			171.6	118.2	11.4	131.0	102.8	8.7			208.4	135.9	11.9	159.2	117.1	9.1
42			3400	12.0	2.0	96.0	76.8	16.0	73.3	67.8	12.2	15.0	1.7	119.9	87.4	16.0	91.6	76.4	12.2
			4000			98.5	84.5	16.4	82.5	82.5	13.8			125.4	96.7	16.7	95.8	85.0	12.8
			4600			102.5	92.6	17.1	89.5	89.5	14.9			131.6	106.3	17.5	100.5	93.8	13.4
	45		3400	21.0	5.8	121.7	86.5	11.6	93.0	75.4	8.9	25.0	4.7	145.2	97.3	11.6	110.9	84.1	8.9
			4000			130.9	96.4	12.5	100.0	84.4	9.5			158.1	109.2	12.6	120.7	94.8	9.7
			4600			138.9	105.8	13.2	106.1	93.0	10.1			169.6	120.6	13.6	129.5	105.1	10.4
		50	3400	30.0	11.4	133.5	91.0	8.9	102.0	79.0	6.8	35.0	9.1	158.9	102.8	9.1	121.3	88.4	6.9
			4000			146.3	102.3	9.8	111.7	89.1	7.4			176.1	116.3	10.1	134.5	100.4	7.7
			4600			157.4	112.8	10.5	120.2	98.5	8.0			191.2	129.0	10.9	146.0	111.7	8.3
42			3400	12.0	2.0	81.6	71.6	13.6	62.1	62.1	10.3	15.0	1.7	101.9	80.6	13.6	77.8	71.0	10.4
			4000			83.7	79.2	13.9	68.8	68.8	11.5			106.6	89.8	14.2	83.6	83.6	11.1
			4600			89.5	89.5	14.9	74.6	74.6	12.4			111.9	99.1	14.9	90.9	90.9	12.1
	45		3400	21.0	5.8	103.5	79.6	9.9	79.0	70.0	7.5	25.0	4.7	123.4	88.7	9.9	94.3	77.4	7.5
			4000			111.2	89.1	10.6	85.0	78.7	8.1			134.4	100.1	10.7	102.6	87.6	8.2
			4600			118.1	98.2	11.2	84.3	84.3	8.0			144.1	110.9	11.5	110.1	97.5	8.8
		50	3400	30.0	11.4	113.5	83.3	7.6	86.7	73.0	5.8	35.0	9.1	135.1	93.2	7.7	103.1	81.0	5.9
			4000			124.3	94.0	8.3	95.0	82.5	6.3			149.7	105.9	8.6	114.4	92.3	6.5
			4600			133.8	103.9	8.9	102.2	91.5	6.8			162.5	117.9	9.3	124.1	103.0	7.1

Hydronic Cooling Selection

180YSHW - 180YSVW CHILLED WATER COOLING CAPACITIES

ENT. WTR. °F	CFM	180YSHW4 / 180YSVW4 (4 ROW COIL)									180YSHW6 / 180YSVW6 (6 ROW COIL)								
		GPM	WTR. P.D. FT.	80°F DB/67°F WB ENT. AIR			75°F DB/63°F WB ENT. AIR			GPM	WTR. P.D. FT.	80°F DB/67°F WB ENT. AIR			75°F DB/63°F WB ENT. AIR				
				TOTAL MBH	SENS. MBH	TEMP. RISE	TOTAL MBH	SENS. MBH	TEMP. RISE			TOTAL MBH	SENS. MBH	TEMP. RISE	TOTAL MBH	SENS. MBH	TEMP. RISE		
42	5200	18.0	2.0	155.0	120.4	17.2	118.4	105.9	13.2	20	1.7	184.0	133.8	18.4	140.5	116.9	14.1		
	6000			157.4	130.2	17.5	134.8	134.8	15.0			188.1	145.0	18.8	143.6	127.4	14.4		
	6800			164.0	141.4	18.2	145.0	145.0	16.1			197.4	158.2	19.7	150.8	139.5	15.1		
	5200	30.0	5.3	194.3	135.3	13.0	148.4	117.7	9.9	30	3.6	218.3	147.2	14.6	166.8	127.4	11.1		
	6000			205.7	148.2	13.7	157.1	129.5	10.5			230.7	161.3	15.4	176.2	140.3	11.7		
	6800			216.6	160.7	14.4	165.4	140.9	11.0			244.4	175.8	16.3	186.6	153.5	12.4		
5200	42.0	10.1	214.9	143.3	10.2	164.1	124.0	7.8	40	6.3	240.6	156.2	12.0	183.8	134.4	9.2			
6000			231.9	158.2	11.0	177.1	137.4	8.4			259.1	172.5	13.0	197.9	149.0	9.9			
6800			246.5	172.1	11.7	188.3	149.9	9.0			276.5	188.4	13.8	211.2	163.3	10.6			
45	5200	18.0	2.0	142.2	115.7	15.8	108.6	102.2	12.1	20	1.7	168.8	128.1	16.9	128.9	112.4	12.9		
	6000			144.4	125.5	16.0	122.6	122.6	13.6			172.6	139.2	17.3	131.8	122.9	13.2		
	6800			150.5	136.6	16.7	131.8	131.8	14.6			181.1	152.2	18.1	156.4	156.4	15.6		
	5200	30.0	5.3	178.3	129.1	11.9	136.1	112.9	9.1	30	3.6	200.3	140.1	13.4	153.0	121.9	10.2		
	6000			188.7	141.7	12.6	144.1	124.4	9.6			211.7	153.9	14.1	161.7	134.5	10.8		
	6800			198.7	154.0	13.2	151.7	135.6	10.1			224.2	168.2	14.9	171.2	147.4	11.4		
5200	42.0	10.1	197.2	136.4	9.4	150.6	118.6	7.2	40	6.3	220.8	148.2	11.0	168.6	128.2	8.4			
6000			212.8	150.8	10.1	162.5	131.6	7.7			237.8	164.0	11.9	181.6	142.4	9.1			
6800			226.2	164.3	10.8	172.7	143.8	8.2			253.7	179.4	12.7	193.8	156.3	9.7			
50	5200	18.0	2.0	120.8	108.0	13.4	93.4	93.4	10.4	20	1.7	143.5	118.7	14.3	110.8	110.8	11.1		
	6000			122.6	122.6	13.6	102.1	102.1	11.3			146.7	129.8	14.7	121.4	121.4	12.1		
	6800			131.8	131.8	14.6	109.8	109.8	12.2			153.9	142.5	15.4	130.4	130.4	13.0		
	5200	30.0	5.3	151.5	119.1	10.1	115.7	104.9	7.7	30	3.6	170.3	128.6	11.4	130.0	112.8	8.7		
	6000			160.4	131.3	10.7	122.5	116.1	8.2			179.9	142.0	12.0	137.4	125.0	9.2		
	6800			168.9	143.2	11.3	122.8	122.8	8.2			190.6	155.7	12.7	145.5	137.5	9.7		
5200	42.0	10.1	167.6	125.1	8.0	128.0	109.7	6.1	40	6.3	187.7	135.2	9.4	143.3	118.0	7.2			
6000			180.8	138.8	8.6	138.1	122.1	6.6			202.1	150.3	10.1	154.3	131.6	7.7			
6800			192.2	151.7	9.2	146.8	133.8	7.0			215.6	165.0	10.8	164.7	144.9	8.2			

240YSHW - 240YSVW CHILLED WATER COOLING CAPACITIES

ENT. WTR. °F	CFM	240YSHW4 / 240YSVW4 (4 ROW COIL)									240YSHW6 / 240YSVW6 (6 ROW COIL)								
		GPM	WTR. P.D. FT.	80°F DB/67°F WB ENT. AIR			75°F DB/63°F WB ENT. AIR			GPM	WTR. P.D. FT.	80°F DB/67°F WB ENT. AIR			75°F DB/63°F WB ENT. AIR				
				TOTAL MBH	SENS. MBH	TEMP. RISE	TOTAL MBH	SENS. MBH	TEMP. RISE			TOTAL MBH	SENS. MBH	TEMP. RISE	TOTAL MBH	SENS. MBH	TEMP. RISE		
42	6000	40.0	5.2	242.0	164.0	12.1	185.0	142.0	9.2	40	5.2	268.0	177.0	13.4	205.0	152.0	10.2		
	8000			276.0	198.0	13.8	210.0	173.0	10.5			308.0	215.0	15.4	235.0	187.0	11.7		
	10000			299.0	228.0	14.9	228.0	200.0	11.4			337.0	250.0	16.9	258.0	219.0	12.9		
	6000	50.0	8.0	259.0	170.0	10.4	198.0	147.0	7.9	50	8.0	289.0	185.0	11.6	221.0	159.0	8.8		
	8000			300.0	207.0	12.0	229.0	180.0	9.2			337.0	227.0	13.5	258.0	196.0	10.3		
	10000			330.0	329.0	13.2	252.0	209.0	10.1			375.0	264.0	15.0	287.0	230.0	11.5		
6000	60.0	11.3	270.0	175.0	9.0	206.0	151.0	6.9	60	11.3	304.0	191.0	10.1	233.0	164.0	7.8			
8000			316.0	214.0	10.5	241.0	185.0	8.0			360.0	236.0	12.0	275.0	203.0	9.2			
10000			351.0	247.0	11.7	268.0	216.0	8.9			405.0	276.0	13.5	309.0	239.0	10.3			
45	6000	40.0	5.2	222.0	156.0	11.1	170.0	136.0	8.5	40	5.2	246.0	168.0	12.3	188.0	145.0	9.4		
	8000			253.0	189.0	12.6	193.0	166.0	9.7			282.0	205.0	14.1	216.0	179.0	10.8		
	10000			274.0	219.0	13.7	209.0	193.0	10.5			309.0	239.0	15.5	236.0	210.0	11.8		
	6000	50.0	8.0	238.0	162.0	9.5	181.0	141.0	7.3	50	8.0	265.0	175.0	10.6	202.0	151.0	8.1		
	8000			275.0	198.0	11.0	210.0	173.0	8.4			309.0	216.0	12.4	236.0	188.0	9.5		
	10000			302.0	229.0	12.1	231.0	201.0	9.2			344.0	252.0	13.8	263.0	221.0	10.5		
6000	60.0	11.3	248.0	166.0	8.3	189.0	144.0	6.3	60	11.3	279.0	181.0	9.3	213.0	156.0	7.1			
8000			290.0	203.0	9.7	221.0	177.0	7.4			330.0	224.0	11.0	252.0	194.0	8.4			
10000			322.0	237.0	10.7	246.0	207.0	8.2			371.0	263.0	12.4	283.0	229.0	9.4			
50	6000	40.0	5.2	189.0	143.0	9.4	144.0	126.0	7.2	40	5.2	209.0	153.0	10.5	169.0	134.0	8.0		
	8000			215.0	175.0	10.7	164.0	155.0	8.2			240.0	189.0	12.0	183.0	167.0	9.2		
	10000			233.0	204.0	11.6	175.0	175.0	8.7			263.0	222.0	13.1	201.0	201.0	10.0		
	6000	50.0	8.0	202.0	148.0	8.1	154.0	130.0	6.2	50	8.0	225.0	160.0	9.0	178.0	140.0	7.1		
	8000			234.0	182.0	9.3	178.0	161.0	7.1			263.0	198.0	10.5	201.0	174.0	8.0		
	10000			257.0	212.0	10.3	182.0	182.0	7.3			293.0	233.0	11.7	223.0	205.0	8.9		
6000	60.0	11.3	211.0	152.0	7.0	161.0	132.0	5.4	60	11.3	237.0	164.0	7.9	187.0	146.0	6.2			
8000			246.0	187.0	8.2	188.0	164.0	6.3			281.0	205.0	9.4	214.0	179.0	7.1			
10000			274.0	219.0	9.1	210.0	193.0	6.9			315.0	242.0	10.5	241.0	212.0	8.0			

Heating Selection

HOT WATER HEATING CAPACITIES 2 ROW COILS

24HWK (2 ROW COIL)					
180°F ENTERING WATER TEMPERATURE					
CFM	GPM	WTR. P.D. FT.	TOTAL MBH	LVG. AIR °F	LVG. WTR. °F
600	3.0	0.9	33.3	121	158
800			38.4	115	154
1000			42.9	110	151
600	6.0	3.2	36.6	126	168
800			43.2	120	166
1000			49.0	115	164
600	9.0	6.7	37.9	128	172
800			45.3	122	170
1000			51.8	118	168

36HWK (2 ROW COIL)					
180°F ENTERING WATER TEMPERATURE					
CFM	GPM	WTR. P.D. FT.	TOTAL MBH	LVG. AIR °F	LVG. WTR. °F
1000	4.0	1.6	53.3	119	153
1200			58.7	115	150
1400			65.4	112	148
1000	8.0	6.1	59.4	125	165
1200			66.2	121	164
1400			72.5	118	162
1000	12.0	13.1	61.5	127	170
1200			68.7	123	168
1400			75.4	120	167

*Capacity based on 70 degree air

48HWK (2 ROW COIL)					
180°F ENTERING WATER TEMPERATURE					
CFM	GPM	WTR. P.D. FT.	TOTAL MBH	LVG. AIR °F	LVG. WTR. °F
1400	5.0	2.0	72.8	118	151
1600			78.0	115	149
1800			82.7	113	147
1400	8.0	4.8	79.2	122	160
1600			85.4	119	159
1800			91.4	117	157
1400	12.0	10.4	83.3	125	166
1600			90.2	122	165
1800			97.0	120	164

60HWK (2 ROW COIL)					
180°F ENTERING WATER TEMPERATURE					
CFM	GPM	WTR. P.D. FT.	TOTAL MBH	LVG. AIR °F	LVG. WTR. °F
1800	6.0	3.1	93.1	118	149
2000			98.2	116	147
2200			103.1	113	145
1800	9.0	6.6	100.4	122	158
2000			106.5	119	156
2200			112.6	117	155
1800	12.0	11.5	104.4	124	163
2000			111.0	121	162
2200			117.7	120	160

*Capacity based on 70 degree air

NOTES:

- See page 29 for hot water heating correction factors.
- Optional 6 row coils should not be used for heating.
- Optional 2 row hot water coils can be factory or field installed.
- When these units are used for hot water heating the leaving air temperature must not exceed 145 degrees. At high altitude conditions, blower motor may cutout at a lower L.A.T.
- Freeze protection is recommended anytime the potential for sub-freezing outside air conditions may occur.

Heating Selection

HOT WATER HEATING CAPACITIES 2 ROW COILS

90HWK (2 ROW COIL)					
180°F ENTERING WATER TEMPERATURE					
CFM	GPM	WTR. P.D. FT.	TOTAL MBH	LVG. AIR °F	LVG. WTR. °F
2500	8.0	1.0	146.2	124	143
3000			160.5	120	140
3500			171.5	115	137
2500	14.0	2.8	162.3	130	157
3000			180.4	126	154
3500			196.2	122	153
2500	21.0	6.1	171.1	133	164
3000			191.2	129	162
3500			209.1	125	160

120HWK (2 ROW COIL)					
180°F ENTERING WATER TEMPERATURE					
CFM	GPM	WTR. P.D. FT.	TOTAL MBH	LVG. AIR °F	LVG. WTR. °F
3400	11.0	1.0	198.5	124	144
4000			215.8	120	140
4600			229.4	116	138
3400	18.0	2.8	217.8	129	156
4000			239.8	125	153
4600			257.8	122	151
3400	25.0	5.3	227.8	132	162
4000			251.9	128	160
4600			272.0	125	158

*Capacity based on 70 degree air

180HWK (2 ROW COIL)					
180°F ENTERING WATER TEMPERATURE					
CFM	GPM	WTR. P.D. FT.	TOTAL MBH	LVG. AIR °F	LVG. WTR. °F
5200	17.0	1.9	308.7	125	144
6000			332.3	121	141
6800			352.6	118	138
5200	25.0	4.1	332.3	129	153
6000			360.2	125	151
6800			386.1	123	149
5200	35.0	8.0	347.8	132	160
6000			378.5	128	158
6800			407.5	125	157

240HWK (2 ROW COIL)					
180°F ENTERING WATER TEMPERATURE					
CFM	GPM	WTR. P.D. FT.	TOTAL MBH	LVG. AIR °F	LVG. WTR. °F
6000	15.0	0.9	323	120	137
8000			369	113	131
10000			415	108	125
6000	25.0	2.3	361	126	151
8000			420	119	146
10000			457	112	144
6000	35.0	4.3	382	192	158
8000			449	122	154
10000			494	116	152

*Capacity based on 70 degree air

Notes:

1. See page 29 for hot water heating correction factors.
2. Optional 6 row coils should not be used for heating.
3. Optional 2 row hot water coils can be factory or field installed.
4. When these units are used for hot water heating the leaving air temperature must not exceed 145 degrees. At high altitude conditions, blower motor may cutout at a lower L.A.T.
5. Freeze protection is recommended anytime the potential for sub-freezing outside air conditions may occur.

Heating Selection

HOT WATER HEATING CAPACITIES 4 ROW COILS

24YSHW4 / 24YSVW4 (4 ROW COIL)					
180°F ENTERING WATER TEMPERATURE					
CFM	GPM	WTR. P.D. FT.	TOTAL MBH	LVG. AIR °F	LVG. WTR. °F
600	3.0	1.2	47.5	143	148
800			56.4	135	142
1000			64.3	130	137
600	6.0	4.4	52.0	150 ⁴	163
800			63.2	143	159
1000			73.3	138	156
600	9.0	9.3	53.6	153 ⁴	168
800			65.8	146	165
1000			76.8	141	163

36YSHW4 / 36YSVW4 (4 ROW COIL)					
180°F ENTERING WATER TEMPERATURE					
CFM	GPM	WTR. P.D. FT.	TOTAL MBH	LVG. AIR °F	LVG. WTR. °F
1000	4.0	2.0	75.5	140	142
1200			83.9	135	138
1400			91.7	131	134
1000	8.0	7.5	83.9	148 ⁴	159
1200			94.7	143	156
1400			105.1	140	154
1000	12.0	16.3	86.8	150 ⁴	165
1200			98.9	146 ⁴	163
1400			110.1	143	162

*Capacity based on 70 degree air

48YSHW4 / 48YSVW4 (4 ROW COIL)					
180°F ENTERING WATER TEMPERATURE					
CFM	GPM	WTR. P.D. FT.	TOTAL MBH	LVG. AIR °F	LVG. WTR. °F
1400	6.0	3.9	106.3	140	145
1600			114.9	137	142
1800			123.3	133	139
1400	10.0	10.3	114.9	146 ⁴	157
1600			125.3	143	155
1800			135.3	140	153
1400	13.0	17.0	118.0	148 ⁴	162
1600			129.4	145	160
1800			140.0	142	158

60YSHW4 / 60YSVW4 (4 ROW COIL)					
180°F ENTERING WATER TEMPERATURE					
CFM	GPM	WTR. P.D. FT.	TOTAL MBH	LVG. AIR °F	LVG. WTR. °F
1800	6.0	1.8	128.0	136	137
2000			136.2	133	135
2200			143.8	131	132
1800	11.0	5.7	142.6	143	154
2000			152.9	141	152
2200			162.6	138	150
1800	16.0	11.6	149.6	147 ⁴	161
2000			160.8	144	160
2200			171.4	142	159

*Capacity based on 70 degree air

NOTES:

1. See page 29 for hot water heating correction factors.
2. Optional 6 row coils should not be used for heating.
3. Optional 2 row hot water coils can be factory or field installed.
4. When these units are used for hot water heating the leaving air temperature must not exceed 145 degrees. At high altitude conditions, blower motor may cutout at a lower L.A.T.
5. Freeze protection is recommended anytime the potential for sub-freezing outside air conditions may occur.

Heating Selection

HOT WATER HEATING CAPACITIES 4 ROW COILS

90YSHW4 / 90YSVW4 (4 ROW COIL)					
180°F ENTERING WATER TEMPERATURE					
CFM	GPM	WTR. P.D. FT.	TOTAL MBH	LVG. AIR °F	LVG. WTR. °F
2500	10.0	2.2	207.8	147 ⁴	138
3000			232.4	142	133
3500			255.2	137	129
2500	15.0	4.7	222.4	152 ⁴	150
3000			251.1	148 ⁴	146
3500			278.5	144	143
2500	22.0	9.8	232.8	156 ⁴	159
3000			265.1	152 ⁴	156
3500			295.7	148 ⁴	153

120YSHW4 / 120YSVW4 (4 ROW COIL)					
180°F ENTERING WATER TEMPERATURE					
CFM	GPM	WTR. P.D. FT.	TOTAL MBH	LVG. AIR °F	LVG. WTR. °F
3400	12.0	2.0	273.2	144	135
4000			302.6	140	130
4600			328.3	136	125
3400	21.0	5.8	301.4	152 ⁴	151
4000			337.0	148 ⁴	148
4600			370.7	144	145
3400	30.0	11.4	314.4	156 ⁴	159
4000			352.9	152 ⁴	156
4600			389.8	148 ⁴	154

*Capacity based on 70 degree air

180YSHW4 / 180YSVW4 (4 ROW COIL)					
180°F ENTERING WATER TEMPERATURE					
CFM	GPM	WTR. P.D. FT.	TOTAL MBH	LVG. AIR °F	LVG. WTR. °F
5200	18.0	2.0	411.0	143	134
6000			449.4	139	130
6800			483.2	136	126
5200	30.0	5.3	450.7	150 ⁴	150
6000			496.9	147 ⁴	147
6800			540.5	143	144
5200	42.0	10.1	471.7	154 ⁴	157
6000			521.8	150 ⁴	155
6800			570.0	148 ⁴	153

240YSHW4 / 240YSVW4 (4 ROW COIL)					
180°F ENTERING WATER TEMPERATURE					
CFM	GPM	WTR. P.D. FT.	TOTAL MBH	LVG. AIR °F	LVG. WTR. °F
6000	40.0	5.2	547	154 ⁴	153
8000			664	147 ⁴	147
10000			768	141	142
6000	50.0	8.0	561	157 ⁴	158
8000			687	150 ⁴	153
10000			799	144	148
6000	60.0	11.3	571	158 ⁴	161
8000			702	151 ⁴	157
10000			819	146 ⁴	153

*Capacity based on 70 degree air

NOTES:

1. See page 29 for hot water heating correction factors.
2. Optional 6 row coils should not be used for heating.
3. Optional 2 row hot water coils can be factory or field installed.
4. When these units are used for hot water heating the leaving air temperature must not exceed 145 degrees. At high altitude conditions, blower motor may cutout at a lower L.A.T.
5. Freeze protection is recommended anytime the potential for sub-freezing outside air conditions may occur.

Physical Data and Dimensions

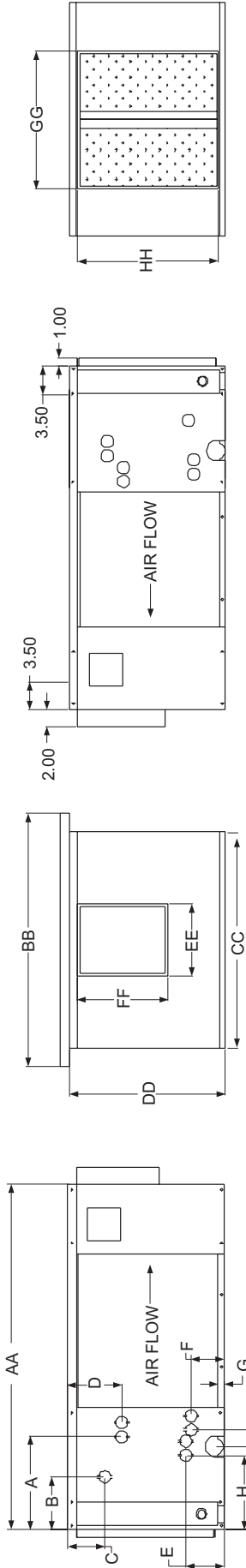

MODEL	UNIT CABINET						BLOWER OUTLET		RETURN DUCT CONNECTION		STUBOUT LOCATION FOR WATER COILS									
	AA	BB	CC	DD	EE	FF	GG	HH	A	B	C	D	E	F	G	H	J	K		
24YSHW4	37	32-1/2	27	18-7/8	8-3/4	10-7/8	18	16-1/4	11-1/4	6-5/16	4-1/2	6-1/2	4-1/2	3-15/16	1	8-15/16	10	12		
36YSHW4	37	42	36-1/2	18-7/8	12-1/4	10-7/8	27-1/2	16-1/4	11-1/4	6-5/16	4-1/2	6-1/2	4-1/2	3-15/16	1	8-15/16	10	12		
48YSHW4	39	43-1/2	38	22-7/8	13-5/8	11-7/8	29	20-1/4	11-1/4	6-5/16	3-3/4	5-3/4	4-1/2	3-15/16	1	8-15/16	10	12		
60YSHW4	42	50-1/2	45	22-7/8	16	13-7/8	36	20-1/4	11-1/4	6-5/16	3-3/4	5-3/4	4-1/2	3-15/16	1	8-15/16	10	12		
24YSHW6	37	32-1/2	27	18-7/8	8-3/4	10-7/8	18	16-1/4	12-15/16	6-5/16	4-1/2	6-1/2	4-1/2	3-15/16	1	10-5/8	10	13-3/4		
36YSHW6	37	42	36-1/2	18-7/8	12-1/4	10-7/8	27-1/2	16-1/4	12-15/16	6-5/16	4-1/2	6-1/2	4-1/2	3-15/16	1	10-5/8	10	13-3/4		
48YSHW6	39	43-1/2	38	22-7/8	13-5/8	11-7/8	29	20-1/4	12-15/16	6-5/16	3-3/4	5-3/4	4-1/2	3-15/16	1	10-5/8	10	13-3/4		
60YSHW6	42	50-1/2	45	22-7/8	16	13-7/8	36	20-1/4	12-15/16	6-5/16	3-3/4	5-3/4	4-1/2	3-15/16	1	10-5/8	10	13-3/4		

NOTES:
 1) All drain connections are 3/4" MPT and located on same side as coil connections.
 2) All units have knockouts on both sides for either right (standard) or left side coil stub outs. (Looking with airflow)

NOTES:
 1) All technical specifications subject to change without notice.
 2) Additional charge for optional motors.
 3) When YSHW units are used with hot water coil the leaving air temperature must not exceed 145 degrees. At high altitude conditions, blower motor may cutout at lower LAT. Contact factory for information.
 4) Contact factory for electric heat information (supplied by others).

MODEL	NOM. COOL TONS	FACE AREA SQ. FT.	TUBE SIZE	STD. MOTOR HP	VOLTS	PHASE	BLOWER SIZE	FILTER SIZE	4 ROW COIL		6 ROW COIL	
									MANIFOLD CONNECTION	SHIPPING WEIGHT	MANIFOLD CONNECTION	SHIPPING WEIGHT
24YSHW	2	2.05	3/8	1/4	115	1	9 x 6	16x 25	7/8" O/D (SWT)	185	7/8" O/D (SWT)	205
36YSHW	3	3.05	3/8	1/3	115	1	9 x 9	16 x 16 (2)	7/8" O/D (SWT)	205	7/8" O/D (SWT)	225
48YSHW	4	4.0	3/8	1/2	115	1	10 x 10	16 x 20 (2)	7/8" O/D (SWT)	240	7/8" O/D (SWT)	265
60YSHW	5	5.0	3/8	1/2	115	1	12 x 12	20 x 20 (2)	1-1/8" O/D (SWT)	290	1-1/8" O/D (SWT)	310

GENERAL SPECIFICATIONS



Quote Date:
 Rev. Date:
 Form No.:
 Dwg. Lev.:
 Scale: NTS

Sold To:
 Cust Purch Order #:

Project Name:
 Location:
 Engineer:
 Contractor:
 For: REFERENCE

PRODUCT DRAWING:
 FAN COIL UNITS - BELT DRIVE
 MODEL YSHW - 2-5 TON
 NOT FOR CONSTRUCTION

Supersedes: Nothing

FORM 115.22-PA1 (1202)

Physical Data and Dimensions

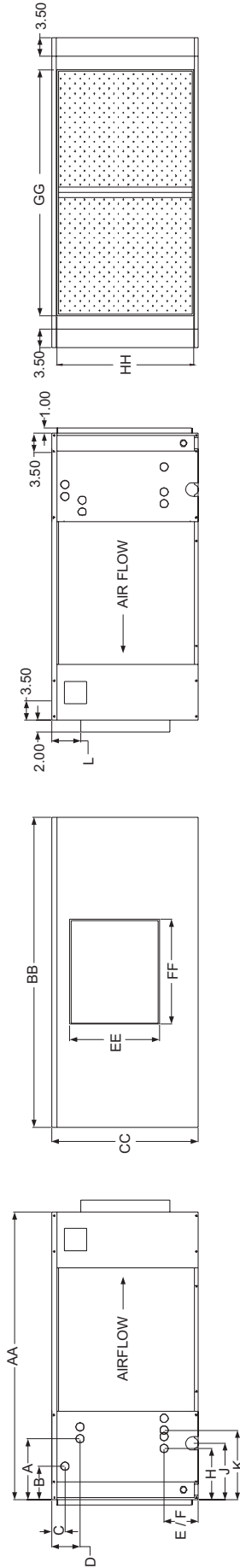

- NOTES:**
- 1) All drain connections are 3/4" MPT and located on same side as coil connections.
 - 2) All units have knockouts on both sides for either right (standard) or left side coil stub outs. (Looking with airflow)
 - 3) 180YSHW and 240YSHW models have two blowers. Blower opening size is 16-3/8 X 16-5/8

GENERAL DIMENSIONS																		
MODEL	UNIT CABINET			BLOWER OUTLET		RETURN DUCT CONNECTION	STUB OUT LOCATION FOR WATER COILS											
	AA	BB	CC	EE	FF		GG	HH	A	B	C	D	E	F	G	H	J	K
90YSHW4	52-1/2	54	27	16-3/8	19-1/8	45	25-1/4	11-1/8	6-1/8	2-7/16	5-1/8	6-7/16	6-7/16	1	9-3/8	10-1/4	12-5/8	1
120YSHW4	52-1/2	57	32	16-3/8	19-1/8	48	30-1/4	11-1/8	6-1/8	2-7/16	5-1/8	6-7/16	6-7/16	1	9-3/8	10-1/4	12-5/8	6
180YSHW4	56-1/2	66	39-1/2	16-3/8	44-3/4	57	37-3/4	11-1/8	6-1/8	2-7/16	5-1/8	6-7/16	6-7/16	1	9-3/8	10-1/4	12-5/8	9-5/16
240YSHW4	62-1/2	66	52	16-3/8	44-3/4	57	50-1/4	11-1/8	6-1/8	2-7/16	5-1/8	6-7/16	6-7/16	1	9-3/8	10-1/4	12-5/8	21-3/4
90YSHW6	52-1/2	54	27	16-3/8	19-1/8	45	25-1/4	13-5/16	6-1/8	2-7/16	5-1/8	6-7/16	6-7/16	1	11-1/2	10-1/4	14-13/16	1
120YSHW6	52-1/2	57	32	16-3/8	19-1/8	48	30-1/4	13-5/16	6-1/8	2-7/16	5-1/8	6-7/16	6-7/16	1	11-1/2	10-1/4	14-13/16	6
180YSHW6	56-1/2	66	39-1/2	16-3/8	44-3/4	57	37-3/4	13-5/16	6-1/8	2-7/16	5-1/8	6-7/16	6-7/16	1	11-1/2	10-1/4	14-13/16	9-5/16
240YSHW6	62-1/2	66	52	16-3/8	44-3/4	57	50-1/4	13-5/16	6-1/8	2-7/16	5-1/8	6-7/16	6-7/16	1	11-1/2	10-1/4	14-13/16	21-3/4

GENERAL SPECIFICATIONS												
MODEL	NOM. COOL TONS	FACE AREA SQ. FT.	TUBE SIZE	STD. MOTOR HP	VOLTS	PHASE	BLOWER SIZE	FILTER SIZE	4 ROW COIL		6 ROW COIL	
									MANIFOLD CONNECTION	SHIPPING WEIGHT	MANIFOLD CONNECTION	SHIPPING WEIGHT
90YSHW	7-1/2	7.5	1/2	3/4	115/230	1	15 x 15	24 x 25 (2)	1-1/8" O/D (SWT)	450	1-1/8" O/D (SWT)	475
120YSHW	10	9.6	1/2	1-1/2	230/460	3	15 x 15	26 x 29 (2)	1-3/8" O/D (SWT)	490	1-3/8" O/D (SWT)	535
180YSHW	15	14.3	1/2	1-1/2	230/460	3	15 x 12 (2)	20 x 36.5 (3)	1-3/8" O/D (SWT)	670	1-3/8" O/D (SWT)	710
240YSHW	20	19.1	1/2	3	230/460	3	15 x 12 (2)	20 x 49 (3)	1-3/8" O/D (SWT)	835	1-3/8" O/D (SWT)	880

- NOTES:**
- 1) All technical specifications subject to change without notice.
 - 2) Additional charge for optional motors.
 - 3) When YSHW units are used with hot water coil the leaving air temperature must not exceed 145 degrees. At high altitude conditions, blower motor may cutout at a lower LAT. Contact factory for information.
 - 4) Contact factory for electric heat information (supplied by others).

YORK
 Copyright © York International Corp. 2002

PRODUCT DRAWING: Project Name: _____
 Location: _____
 Engineer: _____
 Contractor: _____
 For: REFERENCE

Sold To: _____
 Cust Purch Order #: _____

Quote Date: _____
 Rev. Date: _____
 Form No.: _____
 Dwg. Lev.: _____
 Dwg. Scale: NTS

Supercedes: Nothing

FORM 115.22-PA2 (1202)

Physical Data and Dimensions

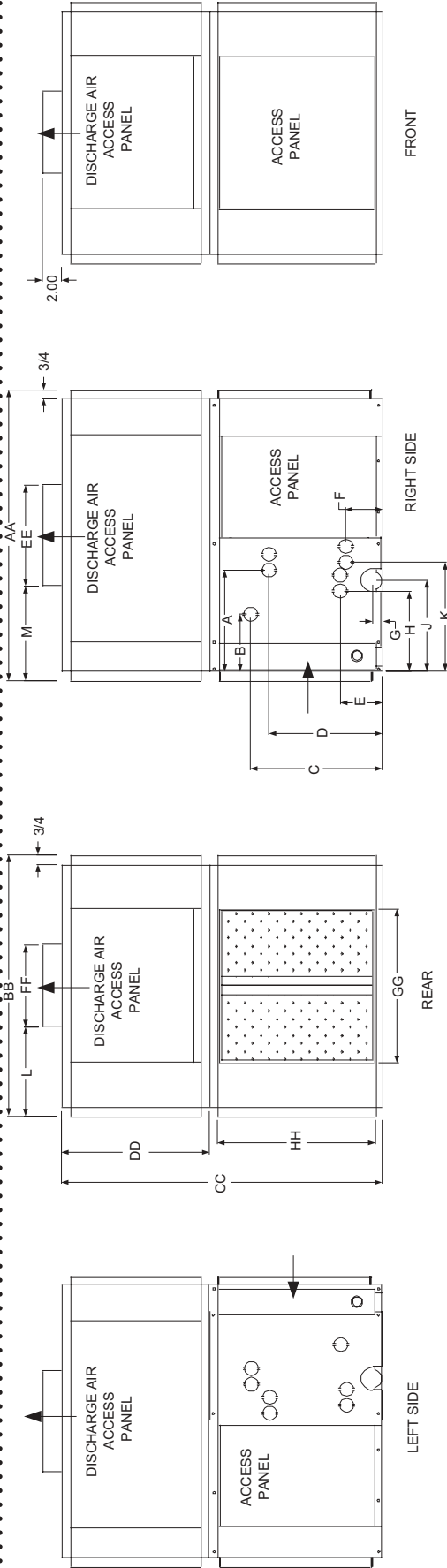

GENERAL DIMENSIONS

MODEL	UNIT CABINET			BLOWER OUTLET		RETURN DUCT CONNECTION		STUBOUT LOCATION FOR WATER COILS												
	AA	BB	CC	DD	EE	FF	GG	HH	A	B	C	D	E	F	G	H	J	K	L	M
24YSVW4	31-3/4	28-1/2	35-1/8	16-1/4	11	9	18	16-1/4	11-1/4	6-5/16	14-5/16	12-5/16	4-1/2	3-15/16	1	8-15/16	10	12	9-3/4	6-3/4
36YSVW4	31-3/4	38	35-1/8	16-1/4	10-7/8	12-5/8	27-1/2	16-1/4	11-1/4	6-5/16	14-5/16	12-5/16	4-1/2	3-15/16	1	8-15/16	10	12	12-3/4	6-3/4
48YSVW4	31-3/4	39-1/2	41-7/8	19	11-3/4	13-5/8	29	20-1/4	11-1/4	6-5/16	19	17	4-1/2	3-15/16	1	8-15/16	10	12	13	7
60YSVW4	31-1/4	46-1/2	43-1/8	20-1/4	13-7/8	16	36	20-1/4	11-1/4	6-5/16	19	17	4-1/2	3-15/16	1	8-15/16	10	12	15-1/8	7-5/8
24YSVW6	31-3/4	28-1/2	35-1/8	16-1/4	11	9	18	16-1/4	12-15/16	6-5/16	14-5/16	12-5/16	4-1/2	3-15/16	1	10-5/8	10	13-3/4	9-3/4	6-3/4
36YSVW6	31-3/4	38	35-1/8	16-1/4	10-7/8	12-5/8	27-1/2	16-1/4	12-15/16	6-5/16	14-5/16	12-5/16	4-1/2	3-15/16	1	10-5/8	10	13-3/4	12-3/4	6-3/4
48YSVW6	31-3/4	39-1/2	41-7/8	19	11-3/4	13-5/8	29	20-1/4	12-15/16	6-5/16	19	17	4-1/2	3-15/16	1	10-5/8	10	13-3/4	13	7
60YSVW6	31-1/4	46-1/2	43-1/8	20-1/4	13-7/8	16	36	20-1/4	12-15/16	6-5/16	19	17	4-1/2	3-15/16	1	10-5/8	10	13-3/4	15-1/8	7-5/8

NOTES:
 1) All drain connections are 3/4" MPT and located on same side as coil connections.
 2) All units have knockouts on both sides for either right (standard) or left side coil stub outs. (Looking with airflow).

GENERAL SPECIFICATIONS

MODEL	NOM. COOL TONS	FACE AREA SQ. FT.	TUBE SIZE	STD. MOTOR HP	VOLTS	PHASE	BLOWER SIZE	FILTER SIZE	4 ROW COIL		6 ROW COIL	
									MANIFOLD CONNECTION	SHIPPING WEIGHT	MANIFOLD CONNECTION	SHIPPING WEIGHT
24YSVW	2	2.05	3/8	1/4	115	1	9 x 6	16x25	7/8" OD (SWT)	185	7/8" OD (SWT)	205
36YSVW	3	3.05	3/8	1/3	115	1	9 x 9	16 x 16 (2)	7/8" OD (SWT)	225	7/8" OD (SWT)	245
48YSVW	4	4.0	3/8	1/2	115	1	10 x 10	16 x 20 (2)	7/8" OD (SWT)	265	7/8" OD (SWT)	290
60YSVW	5	5.0	3/8	1/2	115	1	12 x 12	20 x 20 (2)	1-1/8" OD (SWT)	345	1-1/8" OD (SWT)	365

NOTES:
 1) All technical specifications subject to change without notice.
 2) Additional charge for optional motors
 3) When YSVW units are used with hot water coil the leaving air temperature must not exceed 145 degrees. At high altitude conditions, blower motor may cutout at a lower LAT. Contact factory for information.
 4) Contact factory for electric heat information (supplied by others).



PRODUCT DRAWING:
 FAN COIL UNITS – BELT DRIVE
 MODEL YSVW — 2-5 TON
 NOT FOR CONSTRUCTION

Project Name: _____
 Location: _____
 Engineer: _____
 Contractor: _____
 For: REFERENCE

Sold To: _____
 Cust Purch Order #: _____

Quote Date: _____
 Rev. Date: _____
 Form No.: _____
 Dwg. Lev.: _____
 Dwg. Scale: NTS

FORM 115.22-PA3 (1202)

Physical Data and Dimensions

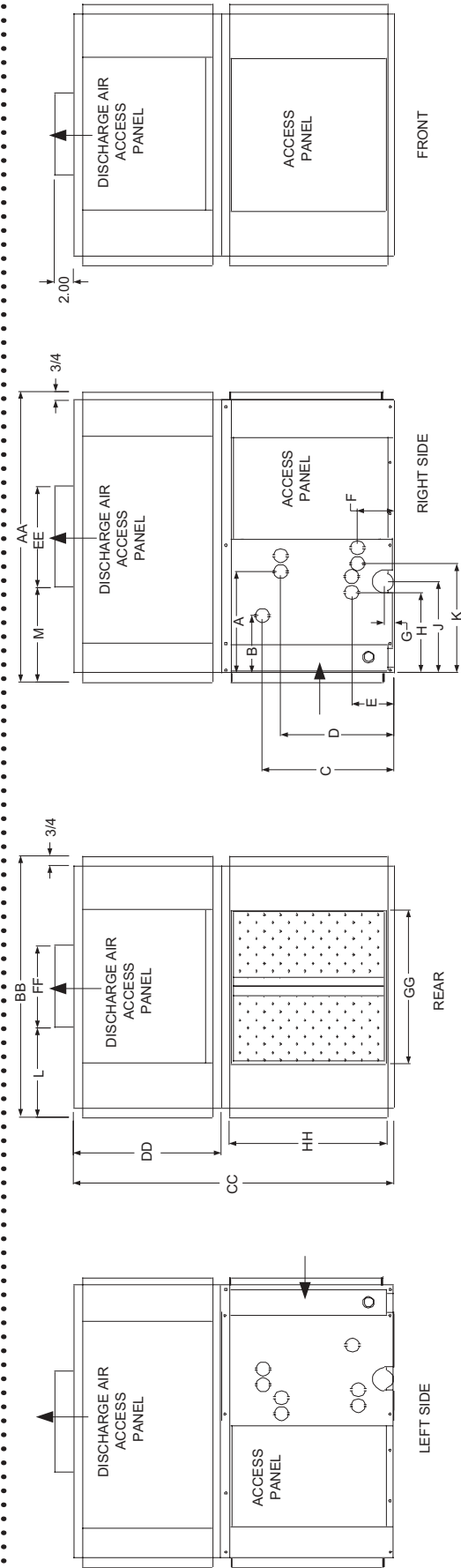

NOTES:
 1) All drain connections are 3/4" MPT and located on same side as coil connections.
 2) All units have knockouts on both sides for either right (standard) or left side coil stub outs. (Looking with airflow).

GENERAL DIMENSIONS																					
MODEL	UNIT CABINET				BLOWER OUTLET		RETURN DUCT CONNECTION		STUBOUT LOCATION FOR WATER COILS												
	AA	BB	CC	DD	EE	FF	GG	HH	A	B	C	D	E	F	G	H	I	J	K	L	M
90YSVW4	37-1/2	55-1/2	51	24	16-3/8	19-1/8	45	25-1/4	11-1/2	6-1/2	24-1/2	21-3/4	6-3/8	6-3/8	1	9-3/4	10-5/8	12-1/2	18-1/4	11-1/4	11-1/4
120YSVW4	37-1/2	58-1/2	56	24	16-3/8	19-1/8	48	30-1/4	11-1/2	6-1/2	29-1/2	36-3/4	6-3/8	6-3/8	1	9-3/4	10-5/8	12-1/2	19-3/4	9-3/4	9-3/4
180YSVW4	46-1/4	66	63-1/8	23-5/8	16-1/2	45	57	37-3/4	11-1/2	6-1/2	37	34-1/4	6-3/8	6-3/8	1	9-3/4	10-5/8	12-1/2	11-1/4	9	9
240YSVW4	46-1/4	66	75-1/2	23-5/8	16-1/2	45	57	50-1/4	11-1/2	6-1/2	49-1/2	46-3/4	6-3/8	6-3/8	1	9-3/4	10-5/8	12-1/2	11-1/4	9	9
90YSVW6	37-1/2	55-1/2	51	24	16-3/8	19-1/8	45	25-1/4	13-5/8	6-1/2	24-1/2	21-3/4	6-3/8	6-3/8	1	11-7/8	10-5/8	14-11/16	18-1/4	11-1/4	11-1/4
120YSVW6	37-1/2	58-1/2	56	24	16-3/8	19-1/8	48	30-1/4	13-5/8	6-1/2	29-1/2	36-3/4	6-3/8	6-3/8	1	11-7/8	10-5/8	14-11/16	19-3/4	9-3/4	9-3/4
180YSVW6	46-1/4	66	63-1/8	23-5/8	16-1/2	45	57	37-3/4	13-5/8	6-1/2	37	34-1/4	6-3/8	6-3/8	1	11-7/8	10-5/8	14-11/16	11-1/4	9	9
240YSVW6	46-1/4	66	75-1/2	23-5/8	16-1/2	45	57	50-1/4	13-5/8	6-1/2	49-1/2	46-3/4	6-3/8	6-3/8	1	11-7/8	10-5/8	14-11/16	11-1/4	9	9

GENERAL SPECIFICATIONS												
MODEL	NOM. COOL TONS	FACE AREA SQ. FT.	TUBE SIZE	STD. MOTOR HP	VOLTS	PHASE	BLOWER SIZE	FILTER SIZE	4 ROW COIL		6 ROW COIL	
									MANIFOLD CONNECTION	SHIPPING WEIGHT	MANIFOLD CONNECTION	SHIPPING WEIGHT
90YSVW	7-1/2	7.5	1/2	3/4	115/230	1	15 x 15	24 x 25 (2)	1-1/8" O/D (swt)	460	1-1/8" O/D (swt)	485
120YSVW	10	9.6	1/2	1-1/2	230/460	3	15 x 15	26 x 29 (2)	1-3/8" O/D (swt)	575	1-3/8" O/D (swt)	620
180YSVW	15	14.3	1/2	1-1/2	230/460	3	15 x 12 (2)	20 x 36.5 (3)	1-3/8" O/D (swt)	805	1-3/8" O/D (swt)	795
240YSVW	20	19.1	1/2	3	230/460	3	15 x 12 (2)	20 x 49 (3)	1-3/8" O/D (swt)	925	1-3/8" O/D (swt)	965

PRODUCT DRAWING:
 FAN COIL UNITS – BELT DRIVE
 MODEL YSVW — 7.5-20 TON
 NOT FOR CONSTRUCTION

Project Name: _____
 Location: _____
 Engineer: _____
 Contractor: _____
 For: REFERENCE

Sold To: _____
 Cust Purch Order #: _____

Quote Date: _____
 Rev. Date: _____
 Form No.: _____
 Dwg. Lev.: _____
 Dwg. Scale: NTS



FORM 115.22-PA4 (1202)

DX Unit Selection



00790VIP

UNIT SELECTION PROCEDURE



00789VIP

INFORMATION REQUIRED FOR UNIT SELECTION

System Type (circle one) : 2 - pipe (1 coil) or 4 - pipe (sep. htg. & clg. coils)

CFM _____ E.S.P. _____ MOTOR: HP: _____ VOLTAGE: _____ PHASE: _____

COOLING: INDOOR: DB _____ WB _____ OUTDOOR: DB _____

TOTAL BTUH _____ SENS. BTUH _____ GPM _____ EWT _____

HEATING: TOTAL BTUH _____ GPM _____ EWT _____ EAT _____

MISC: _____

MECHANICAL SELECTION

1. In general, unit selection consists of choosing the correct model number that will provide the required BTUH cooling and / or heating capacity.

2. Select the unit model that meets the required total MBH cooling and heating at the required conditions from tables on pages 26-28 for cooling and 30-31 for heating (capacities and air are the same for YSHX and YSVX models). **NOTE:** In 4-pipe applications only 2-row heating available.

Example: Required clg. capacity = 48,000 BTUH clg. @ 45 degree EWT

Unit selected = 48YSHX4

3. To select unit RPM and horsepower, first determine the total static pressure which the unit must operate against. See chart on page 23 for individual component static resistances at various CFM values. For an application **with** duct work the total static consists of the sum of the external statics, e.g. duct and duct grilles, and the applicable blower coil unit component statics from page 23.

After total static pressure has been determined, see pages 24 and 25 to establish required fan RPM and motor HP.

Example: Determine required motor horsepower for a 48YSHX4 having a 4 row cooling coil, a 2 row heating coil, throwaway filter and .3 external static pressure. The unit is to deliver 1500 CFM.

Cabinet	.10
4 row coil (clg)	.31
2 row coil (htg)	.10
Filter	.06
External S.P. (*)	<u>.30</u>
	.87

(*) Unit without duct work, value is zero

From page 24 it is found that the above 48YSHX4 requires a 1/2 horsepower motor to deliver 1500 CFM against a total static pressure of 0.87.

Component Static - YSHX / YSVX

MODEL	NOMINAL CFM	COMPONENT STATIC RESISTANCE (INCHES OF WATER)			
		CABINET	COOLING COIL*	HEATING COIL	FILTER
			4 ROW	2 ROW	
24YSHX / 24YSVX	600	0.09	0.22	0.07	0.04
	700	0.10	0.29	0.09	0.05
	800	0.11	0.36	0.12	0.06
	900	0.12	0.45	0.14	0.07
	1000	0.13	0.54	0.18	0.08
36YSHX / 36YSVX	1000	0.09	0.26	0.08	0.04
	1100	0.10	0.31	0.10	0.05
	1200	0.11	0.36	0.12	0.06
	1300	0.12	0.41	0.13	0.07
	1400	0.13	0.46	0.15	0.08
48YSHX / 48YSVX	1400	0.09	0.29	0.09	0.05
	1500	0.10	0.31	0.10	0.06
	1600	0.11	0.35	0.11	0.06
	1700	0.12	0.39	0.12	0.07
	1800	0.13	0.43	0.13	0.08
60YSHX / 60YSVX	1800	0.10	0.29	0.09	0.05
	1900	0.11	0.31	0.10	0.06
	2000	0.12	0.35	0.11	0.06
	2100	0.13	0.39	0.12	0.07
	2200	0.15	0.43	0.13	0.08
90YSHX / 90YSVX	2500	0.12	0.34	0.13	0.04
	2700	0.14	0.39	0.16	0.05
	3000	0.16	0.45	0.18	0.06
	3250	0.17	0.51	0.21	0.07
	3500	0.19	0.57	0.24	0.08
120YSHX / 120YSVX	3400	0.14	0.37	0.14	0.05
	3700	0.15	0.42	0.16	0.06
	4000	0.17	0.47	0.19	0.07
	4300	0.19	0.53	0.21	0.08
	4600	0.21	0.59	0.24	0.09
180YSHX / 180YSVX	5200	0.16	0.38	0.14	0.05
	5600	0.17	0.43	0.16	0.06
	6000	0.19	0.47	0.18	0.07
	6400	0.21	0.52	0.20	0.08
	6800	0.23	0.58	0.23	0.09
240YSHX / 240YSVX	6000	0.11	0.29	0.10	0.04
	7000	0.16	0.38	0.14	0.05
	8000	0.19	0.48	0.18	0.07
	9000	0.23	0.59	0.23	0.09
	10000	0.29	0.68	0.28	0.11

* Wet coil (dry coil p.d. = wet p.d. x .70)

DX Fan Performance

2-5 TON FAN PERFORMANCE (YSHX AND YSVX)

MODEL	NOMINAL CFM	COIL FACE VELOCITY FPM	TOTAL STATIC PRESSURE - INCHES OF WATER									
			0.5		0.6		0.7		0.8		0.9	
			RPM	HP	RPM	HP	RPM	HP	RPM	HP	RPM	HP
24YSHX	600	300	770	1/6	840	1/6	900	1/6	990	1/4	1050	1/4
	700	350	780	1/6	850	1/6	910	1/4	990	1/4	1040	1/4
24YSVX	800	400	800	1/4	860	1/4	910	1/4	990	1/4	1040	1/4
	900	450	810	1/4	880	1/4	925	1/4	1000	1/4	1050	1/3
	1000	500	830	1/4	900	1/4	950	1/3	1000	1/3	1060	1/3
36YSHX	1000	333	805	1/4	880	1/4	940	1/3	1000	1/3	1060	1/3
	1100	367	810	1/4	890	1/3	940	1/3	1000	1/3	1050	1/2
36YSVX	1200	400	820	1/3	900	1/3	950	1/3	1005	1/2	1050	1/2
	1300	434	840	1/3	905	1/3	960	1/3	1010	1/2	1060	1/2
	1400	466	870	1/3	920	1/3	980	1/2	1020	1/2	1090	1/2
48YSHX	1400	350	720	1/3	775	1/3	825	1/3	870	1/2	910	1/2
	1500	375	740	1/3	785	1/2	830	1/2	875	1/2	920	1/2
48YSVX	1600	400	750	1/2	800	1/2	840	1/2	890	1/2	925	3/4
	1700	425	770	1/2	810	1/2	860	1/2	895	1/2	930	3/4
	1800	450	785	1/2	825	1/2	870	1/2	910	1/2	945	3/4
60YSHX	1800	360	580	1/2	630	1/2	680	1/2	725	1/2	770	3/4
	1900	380	580	1/2	630	1/2	680	1/2	725	1/2	775	3/4
60YSVX	2000	400	590	1/2	635	1/2	680	1/2	730	1/2	770	3/4
	2100	420	600	1/2	640	1/2	690	1/2	730	3/4	770	3/4
	2200	440	600	1/2	645	1/2	690	1/2	735	3/4	775	3/4

7 1/2 -20 TON FAN PERFORMANCE (YSHX AND YSVX)

MODEL	NOMINAL CFM	COIL FACE VELOCITY FPM	TOTAL STATIC PRESSURE - INCHES OF WATER									
			0.6		0.7		0.8		0.9		1.0	
			RPM	HP	RPM	HP	RPM	HP	RPM	HP	RPM	HP
90YSHX	2500	333	580	1/2	600	3/4	640	3/4	690	3/4	710	3/4
	2750	366	580	1/2	605	3/4	640	3/4	690	3/4	710	3/4
90YSVX	3000	400	580	3/4	610	3/4	640	3/4	680	3/4	710	1
	3250	433	590	3/4	630	1	660	1	700	1	715	1
	3500	466	605	1	635	1	670	1	700	1	720	1
120YSHX	3400	354	600	1	630	1	670	1	700	1	730	1-1/2
	3700	385	610	1	650	1	680	1-1/2	705	1-1/2	740	1-1/2
120YSVX	4000	417	630	1-1/2	670	1-1/2	695	1-1/2	710	1-1/2	750	1-1/2
	4300	448	650	1-1/2	685	1-1/2	705	1-1/2	730	1-1/2	770	2
	4600	480	670	1-1/2	700	2	720	2	760	2	790	2
180YSHX	5200	364	590	1-1/2	620	1-1/2	650	1-1/2	690	1-1/2	710	1-1/2
	5600	391	600	1-1/2	630	1-1/2	670	1-1/2	700	1-1/2	720	2
180YSVX	6000	420	610	1-1/2	640	1-1/2	680	1-1/2	700	2	730	2
	6400	447	625	2	660	2	690	2	710	2	740	3
	6800	475	640	2	680	2	700	3	720	3	760	3
240YSHX	6000	314	610	1-1/2	640	1-1/2	670	1-1/2	700	2	730	2
	7000	366	640	2	690	2	710	3	740	3	760	3
240YSVX	8000	419	700	3	720	3	750	3	790	3	800	3
	9000	470	730	5	760	5	800	5	810	5	830	5
	10000	500	800	5	820	5	840	5	880	5	900	5

NOTES:

- 1) Shaded area indicates the R.P.M. and C.F.M. range of the standard motor and pulleys.
- 2) Special pulleys and motors can be factory furnished at an additional charge.
- 3) Horsepower tabulated indicates minimum recommended motor H.P.
- 4) **Rated in accordance with ARI 430.**

DX Fan Performance

2-5 TON FAN PERFORMANCE (YSHX AND YSVX)

NOMINAL CFM	COIL FACE VELOCITY FPM	TOTAL STATIC PRESSURE - INCHES OF WATER											
		1.0		1.2		1.4		1.6		1.8		2.0	
		RPM	HP	RPM	HP	RPM	HP	RPM	HP	RPM	HP	RPM	HP
600	300	1105	1/4	1210	1/3	1310	1/3	1420	1/3	1510	1/2	1600	<u>1/2</u>
700	350	1100	1/4	1200	1/3	1300	1/3	1405	1/2	1500	1/2	1590	<u>1/2</u>
800	400	1100	1/3	1195	1/3	1295	1/2	1395	1/2	1470	1/2	1580	<u>1/2</u>
900	450	1100	1/3	1190	1/3	1290	1/2	1390	1/2	1460	1/2	1540	3/4
1000	500	1110	1/3	1200	1/2	1295	1/2	1390	1/2	1450	3/4	1520	3/4
1000	333	1110	1/2	1230	1/2	<u>1335</u>	<u>1/2</u>	<u>1440</u>	<u>3/4</u>	<u>1540</u>	<u>3/4</u>	<u>1625</u>	<u>3/4</u>
1100	367	1110	1/2	1215	1/2	1325	1/2	<u>1425</u>	<u>3/4</u>	<u>1520</u>	<u>3/4</u>	<u>1615</u>	<u>3/4</u>
1200	400	1110	1/2	1210	1/2	1315	3/4	1415	3/4	<u>1500</u>	<u>3/4</u>	<u>1605</u>	<u>3/4</u>
1300	434	1110	1/2	1220	1/2	1315	3/4	1410	3/4	1490	3/4	---	---
1400	466	1120	1/2	1220	3/4	1320	3/4	1410	3/4	1500	3/4	---	---
1400	350	955	1/2	1050	3/4	1135	3/4	1215	3/4	<u>1300</u>	<u>1</u>	<u>1380</u>	<u>1</u>
1500	375	960	1/2	1050	3/4	1135	3/4	1210	3/4	1295	1	1370	1
1600	400	970	3/4	1050	3/4	1140	3/4	1210	3/4	1290	1	1360	1
1700	425	980	3/4	1065	3/4	1140	3/4	1210	1	1290	1	1350	1
1800	450	985	3/4	1070	3/4	1150	3/4	1215	1	1280	1	1350	1
1800	360	820	3/4	900	3/4	<u>975</u>	<u>3/4</u>	<u>1050</u>	<u>1</u>	<u>1125</u>	<u>1</u>	<u>1200</u>	<u>1-1/2</u>
1900	380	815	3/4	895	3/4	970	3/4	<u>1045</u>	<u>1</u>	<u>1120</u>	<u>1</u>	<u>1190</u>	<u>1-1/2</u>
2000	400	815	3/4	890	3/4	965	1	1040	1	<u>1110</u>	<u>1</u>	<u>1180</u>	<u>1-1/2</u>
2100	420	815	3/4	885	3/4	960	1	1035	1	1105	1-1/2	1175	1-1/2
2200	440	815	3/4	885	3/4	960	1	1030	1	1100	1-1/2	1165	1-1/2

7 1/2 -20 TON FAN PERFORMANCE (YSHX AND YSVX)

NOMINAL CFM	COIL FACE VELOCITY FPM	TOTAL STATIC PRESSURE - INCHES OF WATER									
		1.2		1.4		1.6		1.8		2.0	
		RPM	HP	RPM	HP	RPM	HP	RPM	HP	RPM	HP
2500	333	790	3/4	850	1	915	1-1/2	990	1-1/2	1030	1-1/2
2750	366	780	1	840	1	905	1-1/2	980	1-1/2	1020	1-1/2
3000	400	780	1	835	1-1/2	900	1-1/2	970	1-1/2	1010	1-1/2
3250	433	790	1-1/2	840	1-1/2	900	1-1/2	950	1-1/2	1005	2
3500	466	790	1-1/2	845	1-1/2	900	1-1/2	950	2	1005	2
3400	354	790	1-1/2	850	1-1/2	900	1-1/2	950	2	1005	2
3700	385	800	1-1/2	855	1-1/2	905	2	950	2	1005	2
4000	417	805	1-1/2	860	2	910	2	960	2	1005	3
4300	448	820	2	875	2	915	3	970	3	1010	3
4600	480	830	2	890	3	930	3	980	3	1015	3
5200	364	780	2	830	2	900	2	950	3	1000	3
5600	391	790	2	840	2	905	3	950	3	1000	3
6000	420	795	2	850	3	910	3	960	3	1000	3
6400	447	800	3	860	3	915	3	970	3	1000	5
6800	475	810	3	870	3	920	5	975	5	1005	5
6000	314	795	2	850	3	910	3	960	3	1000	3
7000	366	810	3	880	3	920	5	960	5	1000	5
8000	419	850	5	900	5	940	5	990	5	1020	5
9000	470	890	5	920	5	980	5	---	---	---	---
10000	500	---	---	---	---	---	---	---	---	---	---

NOTES:

- 1) Special pulleys and motors can be factory furnished at an additional charge.
- 2) Horsepower tabulated indicates minimum recommended motor H.P.
- 3) **Rated in accordance with ARI 430.**

DX Cooling Selection

24YSHX, 24YSVX Direct Expansion Cooling Capacities

SUCTION TEMP. °F	CFM	85°F DB / 71°F WB ENT. AIR				80°F DB / 67°F WB ENT. AIR				75°F DB / 63°F WB ENT. AIR			
		TOTAL MBTUH	SENS. MBTUH	LVG AIR °F		TOTAL MBTUH	SENS. MBTUH	LVG AIR °F		TOTAL MBTUH	SENS. MBTUH	LVG AIR °F	
				DB	WB			DB	WB			DB	WB
40	600	35.0	20.3	53.7	52.9	29.2	18.4	51.7	51.0	23.4	16.2	50.0	49.4
	800	41.5	24.7	56.5	55.3	34.6	22.4	54.1	53.0	27.7	19.8	52.0	51.0
	1000	46.5	28.3	58.8	57.2	38.7	25.8	56.1	54.6	31.0	22.9	53.7	52.4
45	600	30.2	18.4	56.6	55.9	24.3	16.4	54.7	54.0	18.5	14.2	53.1	52.5
	800	35.8	22.5	58.9	57.8	28.8	20.2	56.7	55.6	21.9	17.5	54.7	53.7
	1000	40.1	25.9	60.9	59.4	32.3	23.4	58.4	56.9	24.6	20.4	56.1	54.8
50	600	24.9	16.4	59.7	58.9	19.1	14.4	57.8	57.1	13.2	12.1	56.3	55.7
	800	29.5	20.2	61.6	60.4	22.6	17.8	59.4	58.3	15.7	15.1	57.5	56.5
	1000	33.0	23.5	63.2	61.7	25.3	20.8	60.8	59.3	17.7	17.7	58.6	---

36YSHX, 36YSVX Direct Expansion Cooling Capacities

SUCTION TEMP. °F	CFM	85°F DB / 71°F WB ENT. AIR				80°F DB / 67°F WB ENT. AIR				75°F DB / 63°F WB ENT. AIR			
		TOTAL MBTUH	SENS. MBTUH	LVG AIR °F		TOTAL MBTUH	SENS. MBTUH	LVG AIR °F		TOTAL MBTUH	SENS. MBTUH	LVG AIR °F	
				DB	WB			DB	WB			DB	WB
40	1000	55.8	32.7	54.8	53.9	46.5	29.6	52.6	51.8	37.2	26.1	50.8	50.0
	1200	62.0	36.9	56.5	55.4	51.7	33.5	54.1	53.1	41.4	29.7	52.1	51.1
	1400	67.2	40.7	58.1	56.7	56.0	37.0	55.5	54.2	44.8	32.9	53.3	52.0
45	1000	48.1	29.7	57.5	56.6	38.8	26.5	55.4	54.6	29.5	23.0	53.7	53.0
	1200	53.4	33.7	59.0	57.9	43.1	30.2	56.7	55.6	32.8	26.2	54.8	53.8
	1400	57.9	37.2	60.4	58.9	46.7	33.4	57.9	56.5	35.5	29.2	55.7	54.5
50	1000	39.7	26.6	60.4	59.5	30.4	23.3	58.4	57.6	21.1	19.7	56.8	56.0
	1200	44.1	30.3	61.6	60.5	33.8	26.7	59.4	58.3	23.5	22.6	57.6	56.7
	1400	47.8	33.6	62.8	61.3	36.6	29.7	60.4	59.0	25.3	25.3	58.3	---

48YSHX, 48YSVX Direct Expansion Cooling Capacities

SUCTION TEMP. °F	CFM	85°F DB / 71°F WB ENT. AIR				80°F DB / 67°F WB ENT. AIR				75°F DB / 63°F WB ENT. AIR			
		TOTAL MBTUH	SENS. MBTUH	LVG AIR °F		TOTAL MBTUH	SENS. MBTUH	LVG AIR °F		TOTAL MBTUH	SENS. MBTUH	LVG AIR °F	
				DB	WB			DB	WB			DB	WB
40	1400	76.1	44.8	55.4	54.4	63.4	40.6	53.1	52.2	50.8	35.9	51.3	50.4
	1600	82.1	48.9	56.7	55.5	68.4	44.4	54.3	53.2	54.8	39.4	52.2	51.2
	1800	87.3	52.7	57.9	56.5	72.7	48.0	55.3	54.0	58.2	42.6	53.1	51.9
45	1400	65.6	40.7	58.1	57.1	52.9	36.5	55.9	55.0	40.2	31.6	54.1	53.3
	1600	70.7	44.6	59.2	58.0	57.1	40.0	56.9	55.7	43.4	34.8	54.9	53.8
	1800	75.2	48.2	60.2	58.8	60.7	43.3	57.7	56.4	46.2	37.8	55.6	54.4
50	1400	54.1	36.5	60.8	59.8	41.4	32.1	58.8	57.9	28.8	27.2	57.0	56.2
	1600	58.3	40.2	61.8	60.6	44.7	35.4	59.5	58.4	30.0	30.0	57.6	---
	1800	62.0	43.5	62.6	61.2	47.5	38.4	60.2	58.9	32.7	32.7	58.2	---

See page 30 for water heating capacities if using the HWK 2 row coil

DX Cooling Selection

60YSHX, 60YSVX Direct Expansion Cooling Capacities

SUCTION TEMP. °F	CFM	85°F DB / 71°F WB ENT. AIR				80°F DB / 67°F WB ENT. AIR				75°F DB / 63°F WB ENT. AIR			
		TOTAL MBTUH	SENS. MBTUH	LVG AIR °F		TOTAL MBTUH	SENS. MBTUH	LVG AIR °F		TOTAL MBTUH	SENS. MBTUH	LVG AIR °F	
				DB	WB			DB	WB			DB	WB
40	1800	96.7	57.0	55.7	54.6	80.6	51.8	53.4	52.4	64.5	45.8	51.5	50.6
	2000	102.6	61.1	56.7	55.5	85.5	55.6	54.3	53.2	68.4	49.2	52.2	51.2
	2200	107.9	64.9	57.7	56.3	89.9	59.1	55.1	53.9	72.0	52.4	52.9	51.8
45	1800	83.3	51.9	58.3	57.3	67.2	46.5	56.1	55.1	51.1	40.4	54.2	53.4
	2000	88.4	55.8	59.2	58.0	71.3	50.0	56.9	55.7	54.3	43.5	54.9	53.8
	2200	92.9	59.4	60.0	58.6	75.0	53.3	57.6	56.3	57.0	46.5	55.4	54.3
50	1800	68.7	46.6	61.0	60.0	52.7	41.0	58.9	58.0	36.6	34.7	57.2	56.3
	2000	72.9	50.2	61.8	60.6	55.9	44.2	59.5	58.4	37.5	37.5	57.6	---
	2200	76.7	53.6	62.5	61.1	58.7	47.3	60.1	58.8	40.2	40.2	58.1	---

90YSHX, 90YSVX Direct Expansion Cooling Capacities

SUCTION TEMP. °F	CFM	85°F DB / 71°F WB ENT. AIR				80°F DB / 67°F WB ENT. AIR				75°F DB / 63°F WB ENT. AIR			
		TOTAL MBTUH	SENS. MBTUH	LVG AIR °F		TOTAL MBTUH	SENS. MBTUH	LVG AIR °F		TOTAL MBTUH	SENS. MBTUH	LVG AIR °F	
				DB	WB			DB	WB			DB	WB
40	2500	147.9	85.9	53.2	52.6	123.3	77.7	51.2	50.7	98.7	68.5	49.6	49.2
	3000	164.2	97.3	55.0	54.3	136.9	88.2	52.8	52.1	109.5	78.0	50.9	50.3
	3500	176.7	107.1	56.7	55.8	147.3	97.4	54.2	53.4	117.9	86.4	52.1	51.4
45	2500	127.4	77.8	56.2	55.6	102.8	69.4	54.3	53.8	78.2	60.0	52.8	52.3
	3000	141.5	88.5	57.7	57.0	114.1	79.2	55.6	54.9	86.8	68.8	53.8	53.2
	3500	152.2	97.9	59.1	58.2	122.8	87.9	56.8	55.9	93.4	76.6	54.7	54.0
50	2500	105.1	69.5	59.3	58.7	80.5	60.9	57.5	57.0	55.9	51.2	56.0	55.5
	3000	116.7	79.5	60.5	59.8	89.4	69.8	58.4	57.8	62.1	59.1	56.8	56.1
	3500	125.6	88.4	61.6	60.8	96.2	77.9	59.4	58.6	66.3	66.3	57.5	---

120YSHX, 120YSVX Direct Expansion Cooling Capacities

SUCTION TEMP. °F	CFM	85°F DB / 71°F WB ENT. AIR				80°F DB / 67°F WB ENT. AIR				75°F DB / 63°F WB ENT. AIR			
		TOTAL MBTUH	SENS. MBTUH	LVG AIR °F		TOTAL MBTUH	SENS. MBTUH	LVG AIR °F		TOTAL MBTUH	SENS. MBTUH	LVG AIR °F	
				DB	WB			DB	WB			DB	WB
40	3400	196.6	114.8	53.7	53.1	163.9	104.0	51.7	51.1	131.2	91.7	50.0	49.5
	4000	215.0	128.0	55.4	54.6	179.2	116.2	53.1	52.4	143.5	102.8	51.2	50.6
	4600	229.1	139.4	57.0	56.0	191.0	126.9	54.5	53.6	152.9	112.6	52.3	51.6
45	3400	169.4	104.2	56.6	56.0	136.7	93.1	54.7	54.1	104.0	80.5	53.1	52.6
	4000	185.2	116.6	58.0	57.3	149.5	104.4	55.8	55.1	113.7	90.7	54.0	53.4
	4600	197.4	127.6	59.3	58.4	159.3	114.6	56.9	56.1	121.2	99.9	54.9	54.1
50	3400	139.8	93.2	59.6	59.0	107.1	81.7	57.8	57.2	74.4	68.9	56.2	55.7
	4000	152.9	104.8	60.7	60.0	117.1	92.2	58.7	58.0	81.3	78.1	56.9	56.3
	4600	162.9	115.2	61.8	60.9	124.8	101.7	59.5	58.7	86.6	86.6	57.6	---

See page 30-31 for water heating capacities if using the HWK 2 row coil

DX Cooling Selection

180YSHX, 180YSVX Direct Expansion Cooling Capacities

SUCTION TEMP. °F	CFM	85°F DB / 71°F WB ENT. AIR				80°F DB / 67°F WB ENT. AIR				75°F DB / 63°F WB ENT. AIR			
		TOTAL MBTUH	SENS. MBTUH	LVG. AIR °F		TOTAL MBTUH	SENS. MBTUH	LVG. AIR °F		TOTAL MBTUH	SENS. MBTUH	LVG. AIR °F	
				DB	WB			DB	WB			DB	WB
50	5200	298.6	174.7	53.9	53.3	248.9	158.2	51.8	51.3	199.21	139.6	50.1	49.6
	6000	322.8	192.1	55.4	54.6	269.1	174.4	53.1	52.4	215.4	154.3	51.2	50.5
	6800	342.1	207.6	56.7	55.9	285.2	188.8	54.3	53.5	228.2	167.5	52.2	51.4
45	5200	257.3	158.6	56.8	56.1	207.6	141.6	54.8	54.2	157.9	122.6	53.2	52.6
	6000	278.2	175.1	58.0	57.2	224.4	156.8	55.8	55.1	170.7	136.2	54.0	53.3
	6800	294.7	189.8	59.2	58.3	237.8	170.4	56.8	56.0	180.9	148.5	54.8	54.0
50	5200	212.3	141.9	59.7	59.1	162.6	124.4	57.9	57.3	112.9	105.0	56.3	55.8
	6000	229.5	157.3	60.7	60.0	175.8	138.4	58.7	58.0	122.1	117.3	56.9	56.3
	6800	243.2	171.3	61.7	60.8	186.3	151.2	59.4	58.6	128.7	128.7	57.5	---

240YSHX, 240YSVX Direct Expansion Cooling Capacities

SUCTION TEMP. °F	CFM	85°F DB / 71°F WB ENT. AIR				80°F DB / 67°F WB ENT. AIR				75°F DB / 63°F WB ENT. AIR			
		TOTAL MBTUH	SENS. MBTUH	LVG. AIR °F		TOTAL MBTUH	SENS. MBTUH	LVG. AIR °F		TOTAL MBTUH	SENS. MBTUH	LVG. AIR °F	
				DB	WB			DB	WB			DB	WB
40	6000	365	211	52.5	52.0	303	190	50.7	50.2	241	167	49.3	48.9
	8000	433	258	55.2	54.5	359	233	53.0	52.4	286	206	51.2	50.6
	10000	480	296	57.6	56.7	398	269	55.1	54.2	316	238	53.0	52.2
45	6000	313	190	55.6	55.2	251	169	53.9	53.5	189	145	52.6	52.2
	8000	372	234	57.9	57.2	298	209	55.8	55.2	224	181	54.1	53.5
	10000	412	271	59.9	59.0	330	243	57.5	56.7	248	211	55.5	54.7
50	6000	257	169	58.9	58.4	195	147	57.3	56.8	133	123	56.0	55.6
	8000	305	210	60.7	60.0	231	184	58.7	58.1	155	145	57.1	56.3
	10000	337	244	62.4	61.4	256	215	60.1	59.2	183	170	58.1	57.2

See page 31 for water heating capacities if using the HWK 2 row coil

Heating Selection

HOT WATER HEATING CORRECTION FACTORS

ENTERING AIR TEMP. (°F)	ENTERING WATER TEMPERATURE (°F)								
	100	110	120	130	140	150	160	170	180
50	0.455	0.545	0.636	0.727	0.818	0.909	1.000	1.091	1.182
55	0.409	0.500	0.591	0.682	0.773	0.864	0.955	1.045	1.136
60	0.363	0.455	0.545	0.636	0.727	0.818	0.909	1.000	1.091
65	0.318	0.409	0.500	0.591	0.682	0.773	0.864	0.955	1.045
70	0.272	0.363	0.455	0.545	0.636	0.727	0.818	0.909	1.000
75	0.227	0.318	0.409	0.500	0.591	0.682	0.773	0.864	0.955
80	0.182	0.272	0.363	0.455	0.545	0.636	0.727	0.818	0.909

Notes:

1. To determine heating capacity at other than 180 deg. E.W.T. and 70 deg. E.A.T. multiply the selected heating capacity at 180 deg. times the appropriate correction factor from above chart.
2. These correction factors may be used on all York published 180 deg. heating capacities.
3. When YSHW units are used for hot water heating the leaving air temperature must not exceed 145 degrees. At high altitude conditions, blower motor may cutout at a lower L.A.T.

Heating Selection

HOT WATER HEATING CAPACITIES 2 ROW COILS

24HWK (2 ROW COIL)					
180°F ENTERING WATER TEMPERATURE					
CFM	GPM	WTR. P.D. FT.	TOTAL MBH	LVG. AIR °F	LVG. WTR. °F
600	3.0	0.9	33.3	121	158
800			38.4	115	154
1000			42.9	110	151
600	6.0	3.2	36.6	126	168
800			43.2	120	166
1000			49.0	115	164
600	9.0	6.7	37.9	128	172
800			45.3	122	170
1000			51.8	118	168

36HWK (2 ROW COIL)					
180°F ENTERING WATER TEMPERATURE					
CFM	GPM	WTR. P.D. FT.	TOTAL MBH	LVG. AIR °F	LVG. WTR. °F
1000	4.0	1.6	53.3	119	153
1200			58.7	115	150
1400			65.4	112	148
1000	8.0	6.1	59.4	125	165
1200			66.2	121	164
1400			72.5	118	162
1000	12.0	13.1	61.5	127	170
1200			68.7	123	168
1400			75.4	120	167

*Capacity based on 70 degree air

48HWK (2 ROW COIL)					
180°F ENTERING WATER TEMPERATURE					
CFM	GPM	WTR. P.D. FT.	TOTAL MBH	LVG. AIR °F	LVG. WTR. °F
1400	5.0	2.0	72.8	118	151
1600			78.0	115	149
1800			82.7	113	147
1400	8.0	4.8	79.2	122	160
1600			85.4	119	159
1800			91.4	117	157
1400	12.0	10.4	83.3	125	166
1600			90.2	122	165
1800			97.0	120	164

60HWK (2 ROW COIL)					
180°F ENTERING WATER TEMPERATURE					
CFM	GPM	WTR. P.D. FT.	TOTAL MBH	LVG. AIR °F	LVG. WTR. °F
1800	6.0	3.1	93.1	118	149
2000			98.2	116	147
2200			103.1	113	145
1800	9.0	6.6	100.4	122	158
2000			106.5	119	156
2200			112.6	117	155
1800	12.0	11.5	104.4	124	163
2000			111.0	121	162
2200			117.7	120	160

*Capacity based on 70 degree air

NOTES:

1. See page 29 for hot water heating correction factors.
2. Optional 2 row hot water coils can be factory or field installed.
3. When these units are used for hot water heating the leaving air temperature must not exceed 145 degrees. At high altitude conditions, blower motor may cutout at a lower L.A.T.
4. Freeze protection is recommended anytime the potential for sub-freezing outside air conditions may occur.

Heating Selection

HOT WATER HEATING CAPACITIES 2 ROW COILS

90HWK (2 ROW COIL)					
180°F ENTERING WATER TEMPERATURE					
CFM	GPM	WTR. P.D. FT.	TOTAL MBH	LVG. AIR °F	LVG. WTR. °F
2500	8.0	1.0	146.2	124	143
3000			160.5	120	140
3500			171.5	115	137
2500	14.0	2.8	162.3	130	157
3000			180.4	126	154
3500			196.2	122	153
2500	21.0	6.1	171.1	133	164
3000			191.2	129	162
3500			209.1	125	160

120HWK (2 ROW COIL)					
180°F ENTERING WATER TEMPERATURE					
CFM	GPM	WTR. P.D. FT.	TOTAL MBH	LVG. AIR °F	LVG. WTR. °F
3400	11.0	1.0	198.5	124	144
4000			215.8	120	140
4600			229.4	116	138
3400	18.0	2.8	217.8	129	156
4000			239.8	125	153
4600			257.8	122	151
3400	25.0	5.3	227.8	132	162
4000			251.9	128	160
4600			272.0	125	158

*Capacity based on 70 degree air

180HWK (2 ROW COIL)					
180°F ENTERING WATER TEMPERATURE					
CFM	GPM	WTR. P.D. FT.	TOTAL MBH	LVG. AIR °F	LVG. WTR. °F
5200	17.0	1.9	308.7	125	144
6000			332.3	121	141
6800			352.6	118	138
5200	25.0	4.1	332.3	129	153
6000			360.2	125	151
6800			386.1	123	149
5200	35.0	8.0	347.8	132	160
6000			378.5	128	158
6800			407.5	125	157

240HWK (2 ROW COIL)					
180°F ENTERING WATER TEMPERATURE					
CFM	GPM	WTR. P.D. FT.	TOTAL MBH	LVG. AIR °F	LVG. WTR. °F
6000	15.0	0.9	323	120	137
8000			369	113	131
10000			415	108	125
6000	25.0	2.3	361	126	151
8000			420	119	146
10000			457	112	144
6000	35.0	4.3	382	192	158
8000			449	122	154
10000			494	116	152

*Capacity based on 70 degree air

NOTES:

1. See page 29 for hot water heating correction factors.
2. Optional 2 row hot water coils can be factory or field installed.
3. When these units are used for hot water heating the leaving air temperature must not exceed 145 degrees. At high altitude conditions, blower motor may cutout at a lower L.A.T.
4. Freeze protection is recommended anytime the potential for sub-freezing outside air conditions may occur.

Physical Data and Dimensions

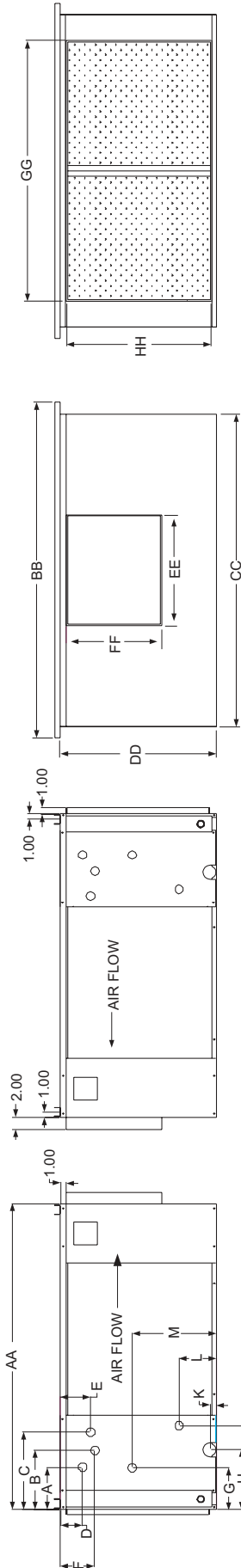

- NOTES:**
- 1) All drain connections are 3/4" MPT and located on same side as coil
 - 2) All units have knockouts on both sides for either right (standard) or left side coil stub outs. (Looking with airflow).

MODEL	UNIT CABINET				BLOWER OUTLET		RETURN DUCT CONNECTION		STUBOUT LOCATION FOR COIL CONNECTIONS											
	AA	BB	CC	DD	EE	FF	GG	HH	A	B	C	D	E	F	G	H	J	K	L	M
24YSHX4	37	31	27	18-7/8	8-3/4	10-7/8	18	16-1/4	8-1/4	10	12-5/16	13-3/4	6-1/2	5-3/4	---	10	13-13/16	1	4	---
36YSHX4	37	40-1/2	36-1/2	18-7/8	12-1/4	10-7/8	27-1/2	16-1/4	8-1/4	10	12-5/16	13-3/4	6-1/2	5-3/4	---	10	13-13/16	1	4	---
48YSHX4	39	42	38	22-7/8	13-5/8	11-7/8	29	20-1/4	---	8-1/2	12-5/16	---	5-3/4	7-1/2	7-1/4	10	13-13/16	1	3-15/16	7-15/16
60YSHX4	42	49	45	22-7/8	16	13-7/8	36	20-1/4	---	8-1/2	12-5/16	---	5-3/4	7-1/2	7-1/4	10	13-13/16	1	3-15/16	7-15/16

GENERAL SPECIFICATIONS											
MODEL	NOM. COOLING TONS	FACE AREA SQ. FT	TUBE SIZE	STD. MOTOR HP.	VOLTS	PHASE	BLOWER SIZE	4 ROW COIL			SHIPPING WEIGHT
								FILTER SIZE	LIQUID (SWEAT)	SUCTION (SWEAT)	
24YSHX	2	1.9	3/8	1/4	115	1	9 x 6	16 x 25	3/8" O/D	3/4" O/D	185
36YSHX	3	2.9	3/8	1/3	115	1	9 X 9	16 x 16 (2)	3/8" O/D	3/4" O/D	215
48YSHX	4	3.9	3/8	1/2	115	1	10 x 10	16 x 20 (2)	1/2" O/D	7/8" O/D	250
60YSHX	5	4.9	3/8	1/2	115	1	12 x 12	20 x 20 (2)	1/2" O/D	7/8" O/D	320

- NOTES:**
- 1) All technical specifications subject to change without notice.
 - 2) Additional charge for optional motors.
 - 3) When YSHX units are used with hot water coil the leaving air temperature must not exceed 145 degrees.



Copyright © York International Corp. 2002

FORM 115.22-PA5 (1202)

PRODUCT DRAWING: Project Name: _____
 Location: _____
 Engineer: _____
 Contractor: _____
 For: REFERENCE

Sold To: _____
 Cust Purch Order #: _____

Quote Date: _____
 Rev. Date: _____
 Form No.: _____
 Dwg. Lev.: _____
 Dwg. Scale: NTS

Supersedes: Nothing

Physical Data and Dimensions

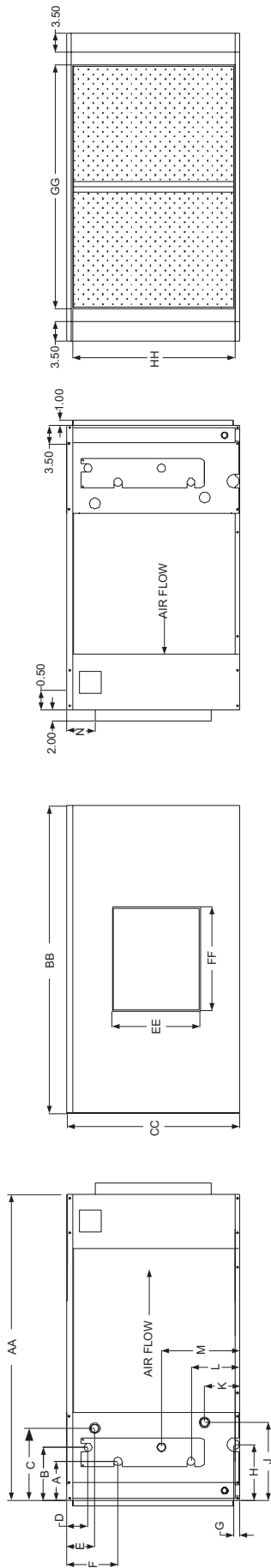

- NOTES:**
- 1) All drain connections are 3/4" MPT and located on same side as coil connections.
 - 2) All units have knockouts on both sides for either right (standard) or left side coil stub outs. (Looking with airflow)

MODEL	UNIT CABINET				BLOWER OUTLET		RETURN DUCT CONNECTION		STUBOUT LOCATION FOR COIL CONNECTIONS													
	AA	BB	CC	DD	EE	FF	GG	HH	A	B	C	D	E	F	G	H	I	J	K	L	M	N
90YSHX4	52-1/2	54	27	16-3/8	19-1/8	45	25-1/4	7-3/16	10-1/8	13-1/4	5-15/16	5-3/16	5-3/16	5-3/16	1	10-1/4	14-3/4	6-3/8	14-1/2	---	---	1
120YSHX4	52-1/2	57	32	16-3/8	19-1/8	48	30-1/4	7-3/16	9-3/4	13-1/4	3-15/16	5-3/16	5-3/16	9-7/16	1	10-1/4	14-3/4	6-3/8	9	14-1/2	---	---
180YSHX4	56-1/2	66	39-1/2	16-3/8	44-3/4	57	37-3/4	7-3/16	9-3/4	13-1/4	5-5/8	5-3/16	5-3/16	11-3/16	1	10-1/4	14-3/4	6-3/8	13-1/4	18-3/4	9-5/16	9-5/16
240YSHX4	62-1/2	66	52	16-3/8	44-3/4	57	50-1/4	7-3/16	9-3/4	13-1/4	5-1/4	5-3/16	5-3/16	13-7/16	1	10-1/4	14-3/4	6-3/8	15-3/4	23-15/16	9-5/16	9-5/16

GENERAL SPECIFICATIONS											
MODEL	NOM. COOLING TONS	FACE AREA SQ. FT	TUBE SIZE	STD. MOTOR HP.	VOLTS	PHASE	BLOWER SIZE	4 ROW COIL			SHIPPING WEIGHT
								FILTER SIZE	LIQUID (SWEAT)	SUCTION (SWEAT)	
90YSHX	7-1/2	7.3	1/2	3/4	115/230	1	15 X 15	24 X 25 (2)	5/8" O.D.	1-1/8" O.D.	400
120YSHX	10	9.4	1/2	1-1/2	230/460	3	15 X 15	26 X 30 (2)	1/2" O.D.	7/8" O.D.	525
180YSHX	15	14.1	1/2	1-1/2	230/460	3	15 X 12 (2)	37-1/2 X 20 (3)	5/8" O.D.	1-1/8" O.D.	775
240YSHX	20	19.1	1/2	3	230/460	3	15 X 12 (2)	50 X 20 (3)	5/8" O.D.	1-1/8" O.D.	835

- NOTES:**
- 1) All technical specifications subject to change without notice
 - 2) Additional charge for optional motors

PRODUCT DRAWING:
 FAN COIL UNITS - BELT DRIVE
 MODEL YSHX - 7.5-20 TON
 NOT FOR CONSTRUCTION

Project Name: _____
 Location: _____
 Engineer: _____
 Contractor: _____
 For: REFERENCE

Sold To: _____
 Cust Purch Order #: _____

Quote Date: _____
 Rev. Date: _____
 Form No.: _____
 Dwg. Lev.: _____
 Dwg. Scale: NTS



Physical Data and Dimensions

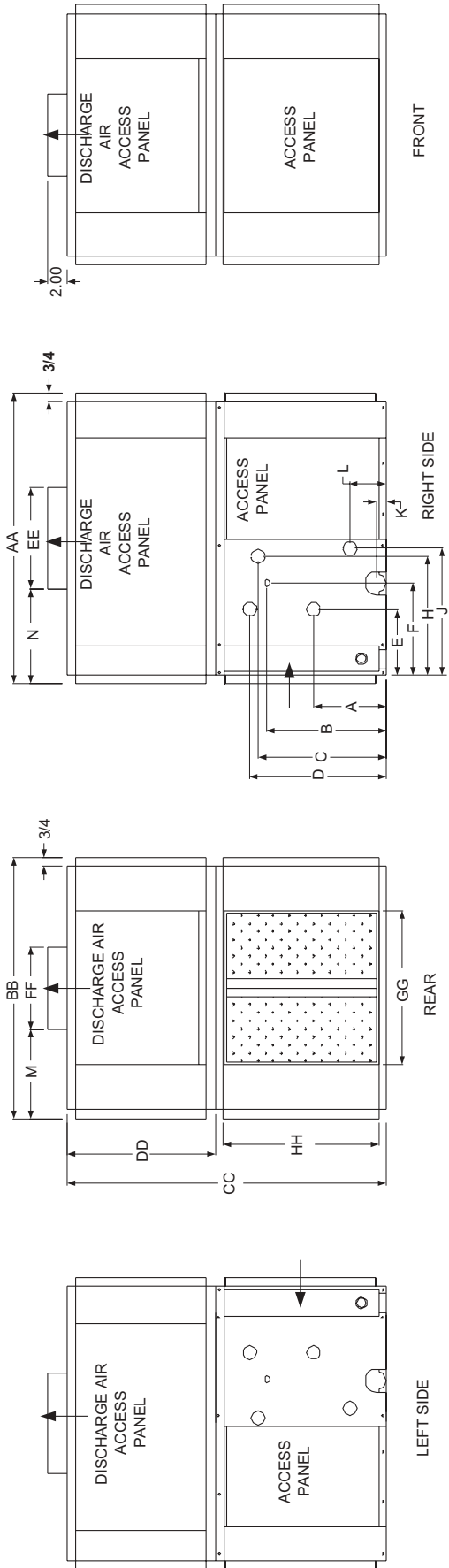

FRONT

RIGHT SIDE

REAR

LEFT SIDE

- NOTES:**
- 1) All drain connections are 3/4" MPT and located on same side as coil connections.
 - 2) All units have knockouts on both sides for either right (standard) or left side coil stub outs. (Looking with airflow).

GENERAL DIMENSIONS		STUBOUT LOCATION FOR COIL CONNECTIONS																					
MODEL	UNIT CABINET				BLOWER OUTLET		RETURN DUCT CONNECTION		STUBOUT LOCATION FOR COIL CONNECTIONS														
	AA	BB	CC	DD	EE	FF	GG	HH	A	B	C	D	E	F	G	H	I	J	K	L	M	N	
24YSVX4	31-3/4	28-1/2	35-1/8	16-1/4	11	9	18	16-1/4	5-7/16	13	12-3/16	---	7	8-1/2	10	13	13-7/8	1	13-7/8	1	3-13/16	9-3/4	6-3/4
36YSVX4	31-3/4	38	35-1/8	16-1/4	10-7/8	12-5/8	27-1/2	16-1/4	5-7/16	13	12-3/16	---	7	8-1/2	10	13	13-7/8	1	13-7/8	1	3-13/16	12-3/4	6-3/4
48YSVX4	31-3/4	39-1/2	41-7/8	19	11-3/4	13-5/8	29	20-1/4	---	15-1/8	16-15/16	8	7-3/16	8-1/2	10	13	13-7/8	1	13-7/8	1	3-13/16	13	7
60YSVX4	31-3/4	46-1/2	43-1/8	20-1/4	13-7/8	16	36	20-1/4	---	15-1/8	16-15/16	8	7-3/16	8-1/2	10	13	13-7/8	1	13-7/8	1	3-13/16	15-1/8	7-5/8

GENERAL SPECIFICATIONS											
MODEL	NOM. COOLING TONS	FACE AREA SQ. FT	TUBE SIZE	STD. MOTOR HP.	VOLTS	PHASE	BLOWER SIZE	4 ROW COIL			SHIPPING WEIGHT
								FILTER SIZE	LIQUID (SWEAT)	SUCTION (SWEAT)	
24YSVX	2	1.9	3/8	1/4	115	1	9 x 6	16 x 25	3/8" O/D	3/4" O/D	195
36YSVX	3	2.9	3/8	1/3	115	1	9 X 9	16 x 16 (2)	3/8" O/D	3/4" O/D	225
48YSVX	4	3.9	3/8	1/2	115	1	10 x 10	16 x 20 (2)	1/2" O/D	7/8" O/D	265
60YSVX	5	4.9	3/8	1/2	115	1	12 x 12	20 x 20 (2)	1/2" O/D	7/8" O/D	345

- Notes:**
- 1) All technical specifications subject to change without notice.
 - 2) Additional charge for optional motors.
 - 3) When YSVX units are used with hot water coil the leaving air temperature must not exceed 145 degrees. At high altitude conditions, blower motor may cutout at a lower LAT. Contact factory for information.
 - 4) Contact factory for electric heat information (supplied by others).

PRODUCT DRAWING:
 FAN COIL UNITS - BELT DRIVE
 MODEL YSVX - 2-5 TON
 NOT FOR CONSTRUCTION

Sold To:
 Cust Purch Order #:

Quote Date:
 Rev. Date:
 Form No.:
 Dwg. Lev.:
 Dwg. Scale: NTS



Supersedes: Nothing

FORM 115.22-PAT (1202)

Physical Data and Dimensions

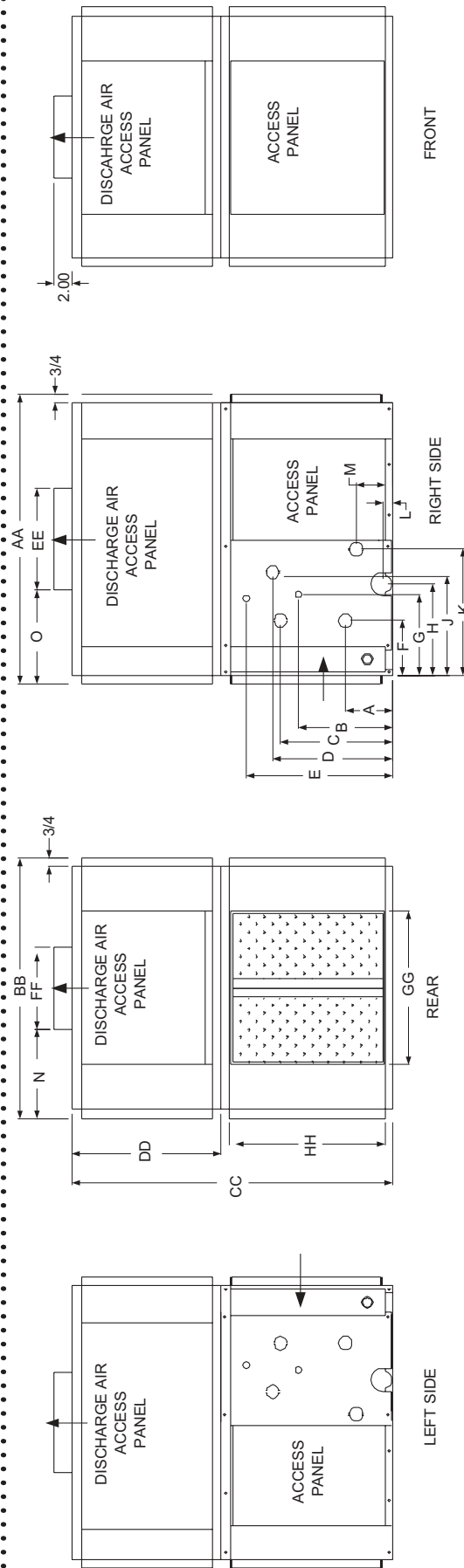

NOTES:

- 1) All drain connections are 3/4" MPT and located on same side as coil connections.
- 2) All units have knockouts on both sides for either right (standard) or left side coil stub outs.
- 3) 180YSVX and 240YSVX models have two blowers. Blower opening size is 16-3/8 X 16-5/8.

GENERAL DIMENSIONS

MODEL	UNIT CABINET				BLOWER OUTLET		RETURN DUCT CONNECTION		STUBOUT LOCATION FOR COIL CONNECTIONS															
	AA	BB	CC	DD	EE	FF	GG	HH	A	B	C	D	E	F	G	H	I	J	K	L	M	N	O	
90YSVX4	37-1/2	55-1/2	51	24	16-3/8	19-1/8	45	24-1/4	14-5/8	---	---	21-3/4	21-1/8	7-3/16	10-1/8	10-5/8	13-1/4	14-3/8	1	6-1/2	18-1/4	11-1/4	11-1/4	11-1/4
120YSVX4	37-1/2	58-1/2	56	24	16-3/8	19-1/8	48	30-1/4	9-1/8	14-5/8	22-5/8	26-3/4	28-1/8	7-3/16	9-3/4	10-5/8	13-1/4	14-3/8	1	6-1/2	19-3/4	9-3/4	9-3/4	9-3/4
180YSVX4	46-1/4	66	63-1/8	23-5/8	16-1/2	45	57	37-3/4	13-3/8	18-7/8	28-3/8	34-3/8	33-3/4	7-3/16	9-3/4	10-5/8	13-1/4	14-3/8	1	6-1/2	11-1/4	11-1/4	11-1/4	9
240YSVX4	46-1/4	66	75-1/2	23-5/8	16-1/2	45	57	50-1/4	15-13/16	24	38-5/8	46-3/4	46-5/8	7-3/16	9-3/8	10-5/8	13-1/4	14-3/8	1	6-1/2	11-1/4	11-1/4	11-1/4	9

GENERAL SPECIFICATIONS

MODEL	NOM. COOLING TONS	FACE AREA SQ. FT	TUBE SIZE	STD. MOTOR HP.	VOLTS	PHASE	BLOWER SIZE	4 ROW COIL			SHIPPING WEIGHT
								FILTER SIZE	LIQUID (SWEAT)	SUCTION (SWEAT)	
90YSVX	7-1/2	7.3	1/2	3/4	115/230	1	15 X 15	24 X 25 (2)	5/8" O.D.	1-1/8" O.D.	460
120YSVX	10	9.4	1/2	1-1/2	230/460	3	15 X 15	26 X 29 (2)	1/2" O.D.	7/8" O.D.	575
180YSVX	15	14.1	1/2	1-1/2	230/460	3	15 X 12 (2)	20 X 36.5 (3)	5/8" O.D.	1-1/8" O.D.	805
240YSVX	20	19.1	1/2	3	230/460	3	15 X 12 (2)	20 X 49 (3)	5/8" O.D.	1-1/8" O.D.	925

- NOTES:**
- 1) All technical specifications subject to change without notice.
 - Additional charge for optional motors.
 - When YSVX units are used with hot water coil the leaving air temperature must not exceed 145 degrees.
 - At high altitude conditions, blower motor may cutout at a lower LAT. Contact factory for information.
 - Contact factory for electric heat information (supplied by others).

PRODUCT DRAWING:
 FAN COIL UNITS - BELT DRIVE
 MODEL YSVX - 7.5-20 TON
 NOT FOR CONSTRUCTION

Project Name:
 Location:
 Engineer:
 Contractor:
 For: REFERENCE

Sold To:
 Cust Purch Order #:

Quote Date:
 Rev. Date:
 Form No.:
 Dwg. Lev.:
 Dwg. Scale: NTS



Options

HWK 2 ROW COIL AND PLENUM BOX

1. Separate 2 row **hot water coil** can be field or factory installed in either the reheat or pre-heat position (reheat is standard).

PART NUMBER	FOR UNIT MODEL	MANIFOLD CONNECTIONS
24HWK	24YSHW/YSVW	7/8" OD
36HWK	36YSHW/YSVW	
48HWK	48YSHW/YSVW	
60HWK	60YSHW/YSVW	
90HWK	90YSHW/YSVW	1-3/8" OD
120HWK	120YSHW/YSVW	
180HWK	180YSHW/YSVW	
240HWK	240YSHW/YSVW	

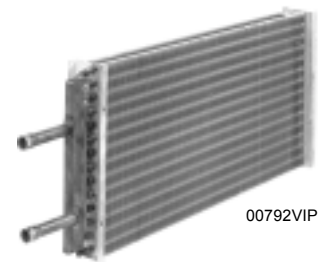

2. **Discharge plenum** with four way double - deflection grille (field installed) (for YSHW units only).

PART NUMBER	FOR UNIT MODEL	DEPTH (1)
24DP	24YSHW	6"
36DP	36YSHW	
48DP	48YSHW	
60DP	60YSHW	
90DP	90YSHW	
120DP	120YSHW	
180DP	180YSHW	
240DP	240YSHW	



(1) Height and width are the same as the unit being attached to.

3. **Relay / Transformer** Part # E301 (24/120V) mounts directly on 4 x 4 junction box on unit series 60 and down, 1/2 HP max, 10 amp max @ 120v.

Options

MB - MIXING BOX

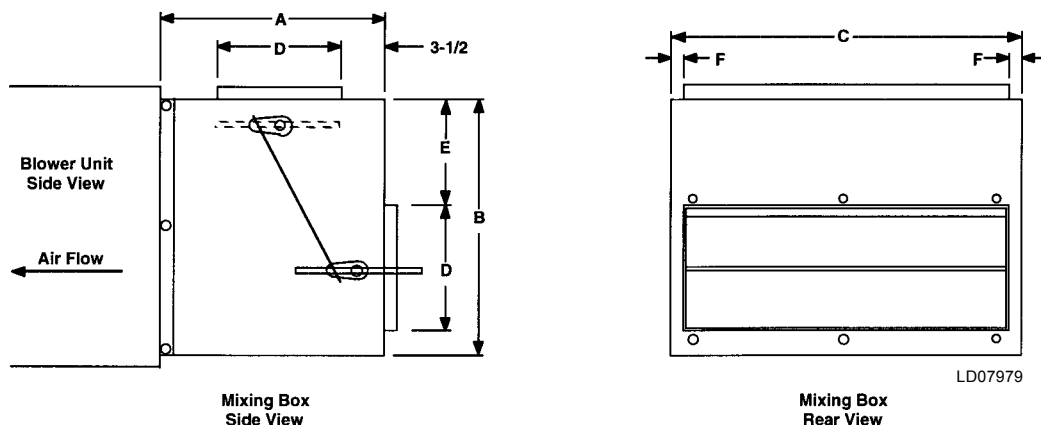

Dimensions:

MODEL	FOR UNIT MODEL	A	B	C	D	E	F	DAMPER SIZE (NOM)	SHIPPING WEIGHT
24MB	24YSH, YSV	16	16-3/8	18-1/8	8	6	1-1/16	2-16 x 8	40
36MB	36YSH, YSV	16	16-3/8	27-5/8	8	6	1-1/16	2-26 x 8	58
48MB	48YSH, YSV	18	20-3/8	29-1/8	10	8	1-1/16	2-27 x 10	65
60MB	60YSH, YSV	18	20-3/8	36-1/8	10	8	1-1/16	2-34 x 10	78
90MB	90YSH, YSV	18	25-3/8	45-1/8	10	8	1-1/16	2-42 x 10	110
120MB	120YSH, YSV	20	30-3/8	48-1/8	12	10	1-1/16	2-46 x 12	135
180MB	180YSH, YSV	22	37-7/8	57-1/8	14	12	1-9/16	2-54 x 14	190
240MB	240YSH, YSV	22	50-1/2	57-1/8	14	24	1-9/16	2-54 x 14	210

Features:

1. Cabinet fully insulated - 3/4 inch.
2. Embossed galvanized cabinet on 24-240MB.
3. Crank arms and linkage rod for damper connection are furnished. Connections can be made on either side of mixing boxes. The balance of necessary linkage hardware, damper motor, and controls to be field supplied.
4. Dampers can be positioned for either rear/top or rear/bottom locations.
5. 1" duct flanges provided on damper openings.
6. Dampers have air seals on the edges for positive closing. 24-90MB have single horizontal damper blades. 120-240MB have double horizontal damper blades.
7. When used with water coil units, a "freezestat" must be installed to prevent coil damage caused by low ambient conditions.

Guide Specifications

Furnish and install York **YSHX/YSVX** for Direct Expansion application and **YSHW/YSVW** for Hydronic applications Series Blower - as indicated on the plans.

CABINETS

Cabinets shall be manufactured of heavy gauge galvanized steel. The entire interior of the cabinet shall be insulated with one inch thick IAQ type insulation. Removable access panels shall be provided on both sides of the cabinet for maintenance and service. All cabinets shall have 2" supply and 1" return flanges.

INSULATION

The entire interior of the cabinet shall be insulated with RX insulation. This insulation must meet the requirements of ASTM C 1071, ASTM G 21, ASTM G 22, NFPA 90A, UL-181, and the cleaning practices of NAIMA.

MOTOR / BLOWERS

Blowers shall be resiliently mounted, with ball bearings, forward curved blade, and of centrifugal type. Each wheel shall be dynamically balanced for smooth, quiet operation. Blowers shall be belt driven with field adjustable pulleys to permit variations in static pressure and air requirements. Standard motors are 1725 RPM either single or three phase. All motors to be field or factory installed and wired at voltage specified by customer.

COILS

All **YSHW/YSVW** series coils shall consist of aluminum fins mechanically bonded onto 3/8" or 1/2" OD seamless copper tubing. All coils shall be leak tested at 350 PSIG minimum air pressure. Manual air vents shall be standard on all coils. Drain pans shall be coated for corrosion protection.

All **YSHX/YSVX** series coils shall consist of aluminum fins mechanically bonded onto 3/8" or 1/2" OD seamless copper tubing. All coils shall be leak tested at 350 PSIG minimum air pressure. 2 - 5 ton models shall feature a piston-type metering device approved for either straight cool or heat pump operation and be of single circuit design. 7 1/2 ton model shall be single circuited and have factory installed expansion valve approved for straight cool only (not heat pump) operation. 10 - 20 ton models shall be dual-circuited and have factory installed expansion valves approved for straight cooling only (not heat pump) operation. Drain pans shall be coated for corrosion protection.

Drain Pans

Air handler shall have positive sloped drain pans for removal of condensate from the pan. Drain pans are to be coated with closed cell foam insulation to provide protection from sweating and corrosion.

FILTERS

One inch throw away filters are standard in 2-5 ton **YSHX/YSVX** and **YSHW/YSVW** units. One inch permanent filters are provided as standard in 7 1/2-20 ton **YSHX/YSVX** and **YSHW/YSVW** units. Filters shall be accessible without tools.

LISTING

All standard units with thermal protected motors are ETL Listed. All air handlers shall be rated in accordance with ARI Standard 430.

Notes:

