



Packaged Rooftop Air Conditioning Units



00566VIP



**50 THROUGH 100 TONS
R-407C and R-22
400VAC/3PH/50Hz**

**Meets ASHRAE 90.1 - 2001
Efficiency Requirements**



ALLY

Introduction

The eco² packaged rooftop – Designed to meet the demands of the market for today and tomorrow.

Better Economy...

Reduce Energy Consumption

- High-efficiency eco² rooftop units are optimized for both R-22 and HFC-407C refrigerant, and are the first environmentally responsible rooftop units that meet the ASHRAE 90.1-2001 efficiency standards.
- Multiple steps of capacity-control offer superior off-design energy performance, while maintaining better control of occupant comfort.
- The OptiLogic™ Control Center ensures that no more than the proper amount of ventilation air is utilized, avoiding the energy cost of conditioning excess air.

Better Ecology...

Air Quality Features for the Indoor Environment

- A double-sloped stainless steel design ensures that all condensate is voided from the drain pan. The drain pan is also visible and accessible for the periodic inspection and cleaning required by IAQ standards.
- Double-wall construction of the roof, floor, doors, and walls prevents insulation fiber from entering the supply air. The inner liner also facilitates periodic cleaning of the unit to prevent harmful build-up of bacteria or contaminants.
- The OptiLogic™ Control Center uses microprocessor logic to analyze and optimize ventilation decisions.
- A true airflow-measurement station can be supplied, to ensure the proper ventilation at all supply-air volumes.
- An available sensor can monitor the CO₂ level within the building and adjust the ventilation rate on demand, to maintain the air quality at a healthy level.

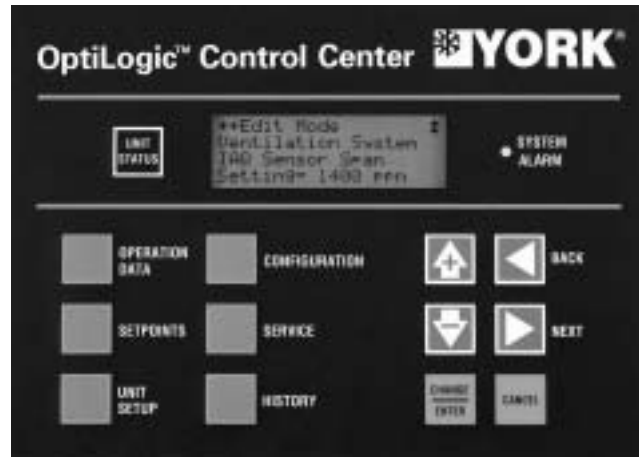

LD07431

The OptiLogic™ Control Center uses microprocessor logic to optimize operation of the eco² rooftop unit.

HFC-407C Refrigerant for the Global Environment

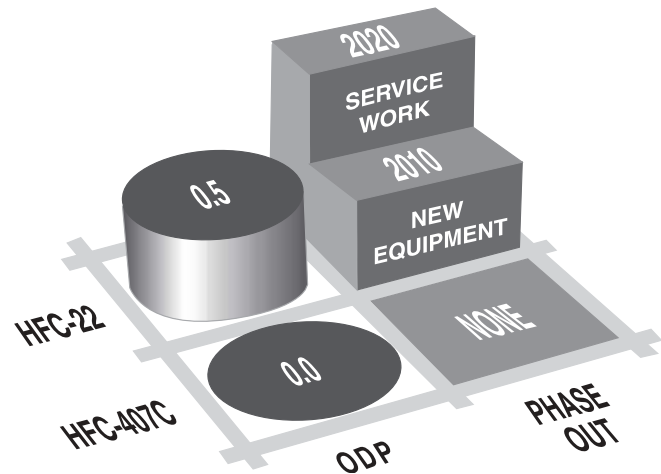

LD07430

TABLE OF CONTENTS

Introduction	2	20 60 Through 65 Ton Exhaust Fan Data	48
Features and Benefits	4	21 70 Through 85 Ton Exhaust Fan Data	49
Nomenclature	7	22 90 Through 95 Ton Exhaust Fan Data	49
Application Data	8	23 Component Static Pressure Drops	50
Physical Data	12	24 Compressor Data	52
Cooling Performance Data	16	25 Supply and Exhaust Fan Motor	
Heating Performance Data – Gas/Electric Heat ...	36	Electrical Data	53
Supply Fan Data	37	26 Condenser Fan Motors	53
Component Static Pressure Drops	40	27 Control Transformer	53
Gas Heat Pressure Drops	44	28 Electric Heat	53
Electric Heat Pressure Drops	46	29 General Arrangement – 50-65 Ton Models	
Exhaust Fan Data	48	(Bottom Supply/Bottom Return)	64
Component Static Pressure Drops	50	30 General Arrangement – 50-65 Ton Models	
Electrical Data	52	(Side Supply/Front Return)	65
Controls	54	31 General Arrangement – 70-95 Ton Models	
Power Wiring	60	(Bottom Supply/Bottom Return)	66
Field Control Wiring	63	32 General Arrangement – 70-95 Ton Models	
General Arrangement Drawings	64	(Side Supply/Front Return)	67
Curb Layout Drawing	69	33 General Arrangement – 70-95 Ton	
Power/Control Entry Drawing	70	Optional Side Return	68
Guide Specifications	71	34 Curb Layout Dimensions	69
		35 Power/Control Dimensions	70

TABLES

1 Physical Data	12
2 Cooling Performance Data – 50 Ton Model	16
3 Cooling Performance Data – 55 Ton Model	18
4 Cooling Performance Data – 60 Ton Model	20
5 Cooling Performance Data – 65 Ton Model	22
6 Cooling Performance Data – 70 Ton Model	24
7 Cooling Performance Data – 75 Ton Model	26
8 Cooling Performance Data – 80 Ton Model	28
9 Cooling Performance Data – 85 Ton Model	30
10 Cooling Performance Data – 90 Ton Model	32
11 Cooling Performance Data – 95 Ton Model	34
12 Gas Heat Performance Data	36
13 Electric Heat Performance Data	36
14 50 Through 65 Ton Supply Fan Data	37
15 70 Through 85 Ton Supply Fan Data	38
16 90 Through 95 Ton Supply Fan Data	39
17 Component Static Pressure Drops	40
18 Gas Heat Pressure Drops	44
19 Electric Heat Pressure Drops	46

FIGURES

1 Single-Point Power Supply Wiring	60
2 Single-Point Power Supply Wiring with	
Non-Fused Disconnect	61
3 Dual-Point Power Supply Wiring	62
4 Field Control Wiring	63
5 Gen. Agmt. Dwg. – 50-65 Ton Models	
(Bottom Supply/Bottom Return)	64
6 Gen. Agmt. Dwg. – 50-65 Ton Models	
(Side Supply/Front Return)	65
7 Gen. Agmt. Dwg. – 70-95 Ton Models	
(Bottom Supply/Bottom Return)	66
8 Gen. Agmt. Dwg. – 70-95 Ton Models	
(Side Supply/Front Return)	67
9 Gen. Agmt. Dwg. – 70-95 Ton Models	
(Optional Side Return)	68
10 Curb Layout Drawing	69
11 Power/Control Entry Drawing –	
50-95 Ton Model	70

Features and Benefits

QUALITY ROOFTOP UNIT DESIGNED TO TODAY'S STANDARDS

Ecological and Economical Design

- First packaged RTU that meets ASHRAE 90.1-2001 with both R-22 and R-407C Refrigerants.
- **Cooling and Heating** – Superior operating performance provides lower operating costs. Smaller steps of cooling capacity provide tighter control of building environment and occupant comfort while optimizing energy efficiency.
- **Indoor Air Quality (IAQ)** – Outside air economizer provides energy savings in free cooling mode, and can provide a healthier and more comfortable building environment by introducing fresh outside air into the building as needed. Indoor Air Quality (IAQ) requirements for building ventilation and comfort are controlled through the microprocessor control panel. Optional air flow measurement provides an accurate means of tracking air quality and alerting the occupants or building owner to unhealthy situations.
- **Premium Efficiency** – Premium-efficiency motors are available for optimum energy efficiency. All motors used on the eco² packaged rooftop air conditioner meet U.S. EPCACT 1992 minimum requirements.
- **VFDs Standard on VAV Units** – Variable-frequency-drives provide the HVAC designer with a high-efficiency, quiet and more reliable means of variable air volume control from a packaged rooftop. On larger rooftops, ASHRAE 90.1-1999 standard specifies part load efficiency requirements that make VFDs the cost-effective solution for meeting the standard.

VFDs can save the owner up to 40% of the energy costs compared to inlet guide vanes offered on competitive units by reducing the power requirement. VFDs use fewer parts, which leads to more reliability. Also, with fewer moving parts, and the reduction of speed in the fan, the VFD operates at significantly quieter operation than the inlet guide vane which restricts a high volume of airflow, which can actually increase noise at part load conditions.

Additionally, the YORK VFD includes DC link reactors as standard that have harmonic filtration comparable to an AC line reactor. VFDs also provide the added benefit of soft-starting the supply fan, which helps to minimize demand charges associated with inrush currents.

- **Network Connectivity with BACnet, LON or Roof-Link Interface** – Through optional communications protocols, the eco² rooftop unit can communicate to any building automation system. There are four options available: BACnet Internet Protocol (Ethernet), BACnet MSTP (RS485), LON or a generic RoofLink BAS interface, depending on the type of building

automation system. Without network communications, the eco² is designed to operate in stand-alone mode, or via contact closures for basic control.

- **Professional Appearance** – A high quality powder coat paint finish is applied to the galvanized steel exterior of the eco² unit to protect it from aggressive environments helping to maintain a factory-quality appearance for years.
- **FlexSys Underfloor Air System Configuration** – the eco² rooftop is the first packaged rooftop product with designs specifically for use with the YORK FlexSys underfloor air system. Ask your local YORK representative for more information.

Indoor Air Quality (IAQ)

- **Double-Sloped Stainless Steel Drain Pan** – This double-sloped inclined stainless steel drain pan facilitates removal of evaporator condensate. Sloped in two directions, this drain pan swiftly drains any condensate from the unit. Best of all, the drain pan is accessible for periodic cleaning required by IAQ standards.
- **Smart Ventilation** – YORK maintains the leadership role in IAQ products with adaptive ventilation control. The OptiLogic™ controls provide continuous monitoring of air quality and take action by opening the outside air dampers, bringing in the right amount of fresh air before air impurities reach uncomfortable or even dangerous levels.
- **Air Flow Measurement** – Precise measurement of ventilation air flow is possible using an air flow measurement station which can be installed in the economizer section. Proper ventilation air flow is required to ensure sufficient fresh air is in the building. A myriad of air flow measurement options are available from minimum air flow to high-accuracy full air flow capabilities. The complete system is designed as an integrated component of the OptiLogic™ control system to ensure optimum system performance.
- **Double Wall Construction** – Rigid double-wall construction throughout provides ease of cleaning and protects against insulation fiber entrainment in the breathable air. Double-wall construction also helps improve the acoustical characteristics of the air handling unit.
- **Enhanced Filtration** – The eco² unit gives designers the flexibility to meet various IAQ requirements with a full range of rigid and throwaway filter options at various efficiency levels.
- **Demand Ventilation** – Control of the economizer is available to maintain a desired ventilation level based on a 0-10VDC input from a sensor. A factory-supplied CO₂ sensor is available for installation in the occupied space.

Reliable Cooling and Heating Technology

- Reliable, efficient, trouble-free operation is the true measure of a packaged rooftop's value. That's why YORK eco² Packaged Rooftop Air Conditioners use established scroll-compressor technology to deliver dependable, economical performance in a wide range of applications. With the eco² Packaged Rooftop, you get the latest generation of compressor enhancements added to the scroll's inherent strengths. The simplicity of a hermetic scroll compressor allows the use of fewer moving parts to minimize breakdown. YORK also employs the latest sealing technology to avoid metal-to-metal contact. Axial sealing is accomplished with floating tip seals, while radial sealing utilizes a microcushion of oil. The result: a maintenance-free compressor providing minimum wear and maximum runtime.
- **Gas Furnace** – The eco² rooftop gas furnace is an induced-draft gas furnace designed for high efficiency and reliability. The furnace uses an aluminized steel tubular heat exchanger and operates at temperatures sufficient to prevent acidic exhaust gases from condensing in the heat exchanger at low fire rates, unlike drum and tube style furnaces that generate condensation formation.

Gas heat units are U.L./C.U.L. listed and are tested to ANSI standard Z21.47. Multiple modules provide redundancy not available in single power burner applications.

Serviceability

- **OptiLogic™** – Fully-integrated factory-packaged controls are standard on every unit and include a display unit with a 4x20 character LCD display. OptiLogic™ continually monitors all control setpoints and configurations. If a unit sensor fails, the controller indicates an alarm. If desired, YORK service can provide remote monitoring and automatically schedule a service technician to make the repair and maintain your comfort.
- **Access Doors** – Full-sized access doors provide easy access into the unit for routine maintenance and inspection.
- **Suction & Discharge Service Valves** – Oversized service valves to provide isolation and quick reclamation and charging of system refrigerant are available to minimize downtime and simplify the service and repair task.
- **Convenience Outlet** – For maintenance tasks requiring power tools, an optional 110V GFCI power supply can power lights, drills or any other power hand tool needed.

- **Filter Maintenance Alarm** – An optional filter maintenance alarm indicates when a filter becomes dirty and requires replacement or cleaning.

Install with Ease and Safety

- **Factory Run-Tested** – Each unit is subjected to a series of quality assurance checks as well as an automated quality control process before being run-tested. Fans and drives are balanced at the factory during testing. The factory run-test ensures safe, proper operation when the unit is installed and reduces installation and commissioning time.
- **Single-Point Power Connection** – Single-point power connection reduces installation time by providing a single-point for incoming power, including the optional convenience outlet. All incoming power is connected in one location, reducing the cost of distributed power wiring.
- **Rain Hoods Rotate Into Place** – No bulky, field-installed rain hoods here. eco² rain hoods ship rotated inside the unit. Once on the job, the installer merely rotates the hood upward, caulks and fastens it in place with sheet metal screws – an easy, one-person job.
- **Factory-mounted and Wired Controls** – All control points within the unit are factory-installed, wired and tested.
- **Non-Fused Disconnect** – An optional factory-installed non-fused disconnect switch simplifies unit installation and serviceability by eliminating the need for a separate disconnect switch. Check local codes for acceptability.

Design Flexibility

- **Low Ambient Operation** – Head-pressure control is accomplished via a VFD motor controller rather than an inefficient and noisy condenser fan damper. By varying the speed of the condenser fan, better control and quieter operation is obtained during the cooler weather. Low ambient controls are available on all systems offering higher mechanical cooling capacity at low ambient conditions than competitive units.
- **Hot Gas Bypass** – Optional on constant volume units, hot gas bypass reduces the cycling of compressors which helps prolong the life of the equipment.
- **Duct Air Openings** – Horizontal connections are available on select configurations, offering more flexibility for duct layout and improving sound transmission characteristics.
- **Compressor Sound Blankets** – For applications in sound-sensitive areas, compressor sound blankets are available to reduce sound emitted from the rooftop unit.

Features and Benefits (continued)

- **Fan Spring Isolators** – One-inch spring isolation is used to prevent vibration transmission from the rooftop unit's supply fan to the building. Two-inch spring isolation is also available.
- **Harsh Environments** – A variety of coil coating and materials are available as well as hail guards to protect coils from weather damage.

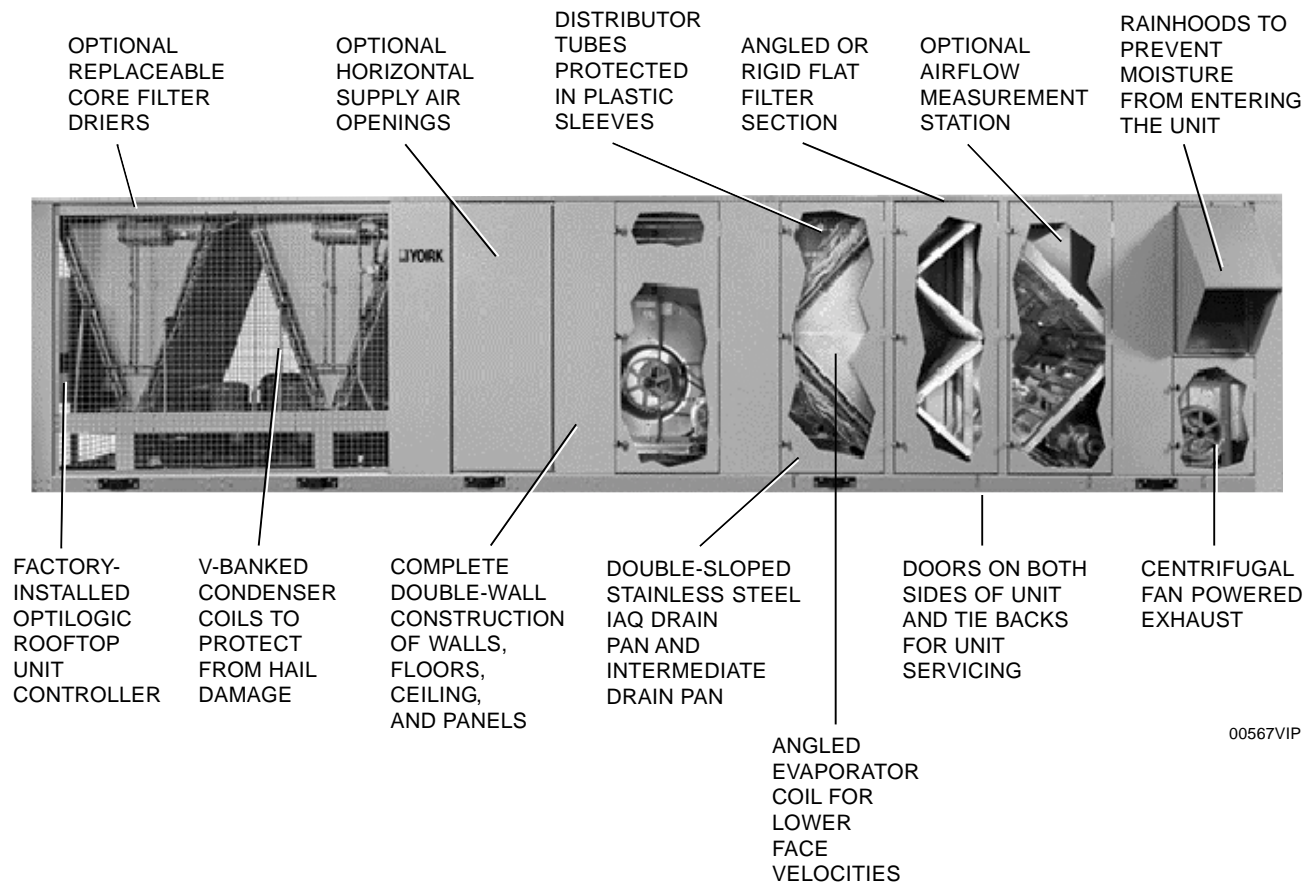

NOMENCLATURE

BASIC MODEL NUMBER

1 2 3 4		5 6 7			8 9		10	11 12		13 14		15 16	
BASE PRODUCT TYPE		NOMINAL CAPACITY			APPLICATION		REFRIGERANT	VOLTAGE		DUCT LOCATIONS		DESIGN SPECIAL	
Y	P	A	L	0	5	0		B	45	B	A		
				5	5	0		C		L		X	
				6	0	0		N		R		S	
				6	5	0		G		B			
				7	0	0		E		R			
				7	5	0		C		S			
				8	0	0		V					
				8	5	0		F					
				9	0	0							
				9	5	0							

Application Data

LOCATION

Of the many factors that can affect the acoustical characteristics of a rooftop installation, one of the most important is the unit location. Ideally, the rooftop unit should be installed away from sound-sensitive areas, such as conference rooms, auditoriums and executive offices. Possible locations could be above storage areas, hallways, mechanical or utility rooms, or bathrooms.

The eco² air conditioning units are designed for outdoor installation. When selecting a site for installation, be guided by the following conditions:

- Unit must be installed on a level surface.
- For the outdoor location of the unit, select a place having a minimum sun exposure and an adequate supply of fresh air for the condenser.
- Also avoid locations beneath windows or between structures.
- Optional condenser coil protection should be used for seashore locations or other harsh environments.
- The unit should be installed on a roof that is structurally strong enough to support the weight of the unit with a minimum of deflection. It is recommended that the unit(s) be installed not more than 15 feet from a main support beam to provide proper structural support and to minimize the transmission of sound and vibration. Ideally, the center of gravity should be located over a structural support or building column.
- Location of unit(s) should also be away from building flue stacks or exhaust ventilators to prevent possible reintroduction of contaminated air through the outside air intakes.
- Be sure the supporting structures will not obstruct the duct, gas or wiring connections.
- Proper service clearance space of 6-feet around the perimeter of the unit, 8-feet on one side for coil servicing, and 12-feet to any adjacent units is required to eliminate cross contamination of exhaust and outdoor air, and for maintenance tasks such as coil pull and cleaning. No obstructions should be above the condensing unit section.

RIGGING

Proper rigging and handling of the equipment is mandatory during unloading and setting it into position to retain warranty status.

Spreader bars must be used by cranes to prevent damage to the unit casing. All lifting lugs must be used when lifting the rooftop unit. Fork lifts will damage the rooftop unit and are not recommended.

Care must be taken to keep the unit in the upright position during rigging and to prevent damage to the watertight seams in the unit casing. Avoid unnecessary jarring or rough handling.

Ground Level Locations

It is important that the units be installed on a substantial base that will not settle, causing strain on the refrigerant lines and sheet metal and resulting in possible leaks. A one-piece concrete slab with footers extended below the frost line is highly recommended. Additionally, the slab should be isolated from the main building foundation to prevent noise and vibration transmission to the building structure.

For ground level installations, precautions should be taken to protect the unit from tampering by, or injury to, unauthorized persons. Erecting a fence around the unit is common practice.

ECONOMIZER

The economizer section is used for ventilation of the conditioned space to maintain indoor air quality, and also to reduce energy consumption by using outdoor air cooling in lieu of mechanical cooling. If outdoor air is appropriate for cooling, but not sufficient for the cooling demand, mechanical cooling will stage on as necessary until the cooling load is met.

Dual (comparative or differential) enthalpy operation is the most accurate and efficient means of economizer operation. The OptiLogic™ control monitors the return and outside air energy content, and selects the lower of the two for operation.

VAV SUPPLY AIR PRESSURE CONTROL

Traditional packaged rooftop systems use inlet guide vanes (IGVs) for duct static pressure control. These control supply duct pressure by modulating dampers (introducing losses and inefficiencies) on the inlet of the fan, open and closed. YORK's variable frequency drives (VFDs) offer superior fan speed control and quieter, energy efficient operation.

For VAV applications, the YORK eco² unit uses a VFD to modulate fan speed and maintain a constant duct static pressure. VFDs offer superior control over the operation of the unit at part load, and offer the additional benefits of quieter and more efficient operation when compared to IGV.

HARSH ENVIRONMENTS – CONDENSER AND EVAPORATOR COIL PROTECTION

For harsh environmental conditions such as seashore applications, YORK offers three types of coil protection: copper fin material, black fin and Technicoat coatings. YORK recommends that for corrosive environments that copper fins be used to protect the evaporator and/or condenser coils. In areas where chemicals that can corrode copper are present, such as ammonia, YORK recommends that the black fin or Technicoat coating be used for maximum protection.

Copper Fin Condenser Coil

Copper fins can be used instead of aluminum for additional corrosion protection, however it is not suitable for areas that are subject to acid rain or exposed to ammonia.

Pre-Coated Condenser Fins

Black fin coating (yellow fin for evaporator fins) is pre-coated application epoxy on aluminum fin stock to guard from corrosive agents and insulate against galvanic potential. It is used for mild seashore or industrial locations. This can provide corrosion resistance comparable to copper fin coils in typical seashore locations.

Post-Coated Condenser Fins

Technicoat (a post-coated application of epoxy) can be used for seashore and other corrosive applications with the exception of strong alkaloids, oxidizers, wet bromide, chlorine and fluorine in concentrations greater than 100 ppm.

Any of the above suitable options should be selected based on the particular project design parameters and related environmental factors. The application should be further reviewed and approved by the consulting engineer or owner based on their knowledge of the job site conditions.

BUILDING EXHAUST SYSTEMS

Building exhaust systems are often necessary when economizers are used to bring in outdoor air. Without proper building exhaust, the building may become over-pressurized. The exhaust system maintains the proper building pressure by expelling the appropriate amount of air from the building. Exhaust systems are typically designed to exhaust approximately 10% less air than what is entering the building. This provides a slight positive pressure in the building.

100% modulating exhaust with building static pressure sensing and control

The 100% exhaust system can be configured with either control actuated dampers or VFDs for modulating control. The unit controller monitors the building pressure using a differential pressure transducer and maintains the required building static pressure by modulating the exhaust control. If the building has other means of exhaust or building pressure is not important, on/off or barometric control may be used.

Powered exhaust with fan on/off control

The 100% exhaust system can be configured for on/off operation eliminating the expense of the damper actuators or VFDs. This exhaust system can be controlled by either the outside air damper position, or a building static pressure sensor.

Barometric exhaust

Barometric exhaust can be used when smaller amounts of air at low static pressure variations within the building or other means of building exhaust are employed. Barometric exhaust is commonly used where there are only small fluctuations in building pressure or where building static pressure control is not necessary.

ROOF CURB

YORK offers optional roof curbs designed specifically for the eco² footprint. These curbs come disassembled and require field assembly and installation. For bottom supply and return openings, the curbs have matching connections to ease installation. A pipe chase that matches the rooftop unit pipe chase is also included in the curb footprint for through-the-curb utility connections.

Application Data (continued)

The curb should be located according to the location recommendations above, and properly sealed to prevent moisture and air leakage into and out of the duct system. Flexible collars should be used when connecting the duct work to prevent unit noise transmission and vibration into the building.

Duct work should be supported independently of the unit.

ACOUSTICAL CONSIDERATIONS

The eco² unit is designed for lower sound levels than competitive units by using flexible fan connections, fan spring isolators, double-wall construction, and lower speed and horsepower fans. For VAV applications, VFDs are used instead of inlet guide vanes. Additional sound attenuation can be obtained using compressor sound blankets and field-supplied sound attenuators when necessary.

Even with these equipment design features, the acoustical characteristics of the entire installation must never be overlooked. Additional steps for the acoustical characteristics of a rooftop installation should be addressed during the design phase of a project to avoid costly alterations after the installation of the equipment. During the design phase of a project, the designing engineer should consider, at a minimum, the impact of the equipment location, rooftop installation, building structure, and duct work.

SELECTION PROCEDURE

Given:

Total Cooling Load	920 mbh
Sensible Heat	610 mbh
Required Heating Capacity	875 mbh
Design Cooling Ambient Temp.	95°F
Indoor Air Temperature	80°F db/67°F wb
Supply Air Flow	24,000 cfm
External Static Pressure	2.25 in. w.c.
Electrical Service	460V/3ph/60 Hz

Unit Configuration/Options: 0-100% modulating economizer, barometric relief, premium efficiency supply fan motor and VFD, and two-inch pleated filters, bottom supply, bottom return.

Select Unit:

1. Determine the internal static pressure drop of the cabinet by referencing Table 17.

Wet evaporator coil	0.58
Bottom return opening	0.15
Two-inch pleated filters	0.12
Mod. econ. dampers	0.56
Total	1.41 IWG

2. Determine the total static pressure by adding the internal to the external static pressure.

$$\text{TSP} = 1.41 \text{ IWG} + 2.25 \text{ IWG} = 3.66 \text{ IWG total static pressure}$$

3. Determine the BHP of the supply fan from Table 15 using the supply air flow and total static pressure. From the table, we interpolate to get 26.3 BHP at 724 rpm.

4. Determine the motor heat gain of supply air flow by first calculating the motor energy and converting it into Btuh.

Motor Energy

$$\text{Motor kW} = \text{BHP} \times .746/\text{efficiency}$$

$$\text{Motor kW} = 26.3 \times 0.746/0.94$$

$$\text{Motor kW} = 20.9 \text{ kW}$$

Motor Heat Rejection (MHR)

$$\text{MHR} = 2545 \times \text{BHP}/\text{efficiency}$$

$$\text{MHR} = 2545 \times 26.3/0.94$$

$$\text{MHR} = 71.2 \text{ mbh}$$

5. Calculate actual required total cooling capacity by adding specified cooling capacity to motor heat rejection.

Required Total Cooling Capacity

$$920 \text{ mbh} + 71.3 \text{ mbh} = 991 \text{ mbh}$$

Required Sensible Cooling Capacity

$$610 \text{ mbh} + 71.3 \text{ mbh} = 681 \text{ mbh}$$

6. Required total and sensible capacities are 991 mbh and 681 mbh, respectively. The total capacity is 82.6 tons, therefore a model YPAL085 is selected. Use the Cooling Performance Data in Table 9. Locate the table with the correct ambient air temperature. Next, trace the 80°F entering air dry bulb temperature to match the 24,000 cfm and 67°F entering wet bulb temperature condition. The resulting conditions are, from the table, 996.5 mbh total cooling capacity and 688.9 mbh sensible cooling capacity.
7. The high heat option for the YPAL085 provides 900 mbh of heat capacity with an input of 1,125 mbh. This is sufficient for the 875 mbh heating requirement.
8. Determine net cooling and heating capacities if required.
- Net Cooling Capacity (NCC)*
 $\text{mbh} = 996.5 \text{ mbh} - 71.3 \text{ mbh}$
 $\text{mbh} = 925 \text{ mbh}$
- Net Sensible Heat Capacity (NSHC)*
 $\text{mbh} = 688.9 \text{ mbh} - 71.3 \text{ mbh}$
 $\text{mbh} = 618 \text{ mbh}$
- Net Heating Capacity (NHC)**
 $\text{mbh} = 875 \text{ mbh} + 71.3 \text{ mbh}$
 $\text{mbh} = 946 \text{ mbh}$
- * Note, net heating capacity is approximate because this example uses the bhp calculated based on a wet evaporator coil (for cooling mode).

Physical Data

TABLE 1 – PHYSICAL DATA – MODELS 50-70

MODEL SIZE	050	055	060	065	070
GENERAL DATA					
Length (cm) w/o Hood	874	874	874	874	1140
Width (cm) w/o Hood	234	234	234	234	234
Height (cm)	208	208	208	208	208
Operating Weights (Kg) (Base Unit, No Options)					
Cooling Only (Rigging & R407C)	3701	3797	3934	4029	5799
Option Weights (Kg)					
Power Exhaust (Blower, Motor, Fan Skid & Mod Damper)	284	284	284	284	341
Power Exhaust (Blower, Motor, Fan Dkid, VFD & Baro Damper)	287	287	287	287	332
100% AMS (Measurement Station & Mounting)	50	50	50	50	57
25/75% AMS (Measurement Station & Mounting)	59	59	59	59	66
Min. AMS (Measurement Station & Mounting)	18	18	18	18	20
Barometric Only	16	16	16	16	20
375 MBH Gas Heat	73	73	73	73	73
750 MBH Gas Heat	147	147	147	147	147
1125 MBH Gas Heat	n/a	n/a	n/a	n/a	220
40 kW	195	195	195	195	204
80 kW	222	222	222	222	231
108 kW	204	204	204	204	213
150 kW	213	213	213	213	222
200 kW	222	222	222	222	231
250 kW	231	231	231	231	240
Condenser Wire Guard	15	15	15	15	18
Copper Condenser Coils (additional)	280	280	360	360	280
Copper Evaporator Coils (additional)	119	145	181	227	127
Roof Curb Weights (Kg)					
14" Full Perimeter Roof Curb	374	374	374	374	463
14" Open Condenser Roof Curb	252	252	252	252	262
Compressor Data					
Quantity/Size (Nominal HP)	4x13	4x13	4x15	4x15	4x10, 2x13
Type	Scroll	Scroll	Scroll	Scroll	Scroll
Capacity Steps (%)	4x25	4x25	4x25	4x25	4x15, 2x20
Supply Fan and Drive					
Quantity	1	1	1	1	1
Type	FC	FC	FC	FC	FC
Size	25-22	25-22	25-22	25-22	28-25
Motor Size Range (Min. to Max. HP)	7.5-40	7.5-40	7.5-40	7.5-40	7.5-60
Air Flow Range (Min. to Max. m3/hr)	16,988-38,228	16,988-38,228	23785-45875	23785-45875	23785-54,367
Static Pressure Range (Min. to Max. ESP)	0-995 Pa	0-995 Pa	0-995 Pa	0-995 Pa	0-995 Pa
Exhaust Fan					
Quantity	2	2	2	2	2
Type	FC	FC	FC	FC	FC
Size	15-15	15-15	15-15	15-15	18-18
Motor Size Range (Min. to Max. HP)	5-20	5-20	5-20	5-20	10-20
Air Flow Range (Min. to Max. m3/hr)	0-33980	0-33980	0-33980	0-33980	0-33980
Static Pressure Range (Min. to Max. ESP)	0-498 Pa	0-498 Pa	0-498 Pa	0-498 Pa	0-498 Pa

TABLE 1 – PHYSICAL DATA – MODELS 50-70 (CONT'D)

MODEL SIZE	050	055	060	065	070
Evaporator Coil					
Size (Square Meters)	5	5	5	5	5
Number of Rows/Fins per cm	1	1	1	1	1
Tube Diameter (cm) /Surface	5/4 /enhanced	5/4 /enhanced	5/4 /enhanced	5/4 /enhanced	5/4 /enhanced
Condenser Coil (Aluminum Fins)					
Size (Square Meters)	11	11	11	11	182
Number of Rows/Fins per cm	1	1	0	0	0
Tube Diameter (cm)	1	1	1	1	1
Condenser Coil (Copper Fins - Opt)					
Size (square meters)	11	11	11	11	17
Number of rows/fins per cm	1	1	0	0	0
Tube Diameter	1	1	1	1	1
Condenser Fans					
Quantity	4	4	4	4	6
Type	Prop.	Prop.	Prop.	Prop.	Prop.
Diameter (Meters)	1	1	1	1	1
Power (Hp Each)	2	2	2	2	2
Filters - 5.08cm Throwaway					
Quantity	8 / 12	8 / 12	8 / 12	8 / 12	10 / 15
Size (Length x Width) (Meters)	.6x.4 / .6x.5	.6x.4 / .6x.5	.6x.4 / .6x.5	.6x.4 / .6x.5	.6x.4 / .6x.5
Total Filter Face Area (Square Meters)	6	6	6	6	7
Filters - 5.08cm Cleanable					
Quantity	8 / 12	8 / 12	8 / 12	8 / 12	10 / 15
Size (Length x Width) (Meters)	.6x.4 / .6x.5	.6x.4 / .6x.5	.6x.4 / .6x.5	.6x.4 / .6x.5	.6x.4 / .6x.5
Total Filter Face Area (Square Meters)	6	6	6	6	7
Filters - 5.08cm Pleated (30% Efficient)					
Quantity	8 / 12	8 / 12	8 / 12	8 / 12	10 / 15
Size (Length x Width) (Meters)	.6x.4 / .6x.5	.6x.4 / .6x.5	.6x.4 / .6x.5	.6x.4 / .6x.5	.6x.4 / .6x.5
Total Filter Face Area (Square Meters)	6	6	6	6	7
Filters -30.48cm Rigid 65%, 5.08cm 30% Prefilter					
Quantity	1 / 4 / 9	1 / 4 / 9	1 / 4 / 9	1 / 4 / 9	2 / 8 / 9
Size (Length x Width) (Meters)	.4x.5 / .6x.4 / .6x.5	.4x.5 / .6x.4 / .6x.5	.4x.5 / .6x.4 / .6x.5	.4x.5 / .6x.4 / .6x.5	.4x.5 / .6x.4 / .6x.5
Total Filter Face Area (Square Meters)	1	1	1	1	1
Filters -30.48cm Rigid 95%, 5.08cm 30% Prefilter					
Quantity	1 / 4 / 9	1 / 4 / 9	1 / 4 / 9	1 / 4 / 9	2 / 8 / 9
Size (Length x Width) (Meters)	.4x.5 / .6x.4 / .6x.5	.4x.5 / .6x.4 / .6x.5	.4x.5 / .6x.4 / .6x.5	.4x.5 / .6x.4 / .6x.5	.4x.5 / .6x.4 / .6x.5
Total Filter Face Area (Square Meters)	1	1	1	1	1
Filters - 5.08cm Carbon (30% Efficient)					
Quantity	1 / 4 / 9	1 / 4 / 9	1 / 4 / 9	1 / 4 / 9	10 / 15
Size (Length x Width) (Meters)	.4x.5 / .6x.4 / .6x.5	.4x.5 / .6x.4 / .6x.5	.4x.5 / .6x.4 / .6x.5	.4x.5 / .6x.4 / .6x.5	.6x.4 / .6x.5
Total Filter Face Area (Square Meters)	1	1	1	1	2
Minimum OA Temp. for Mech. Cig.	45	45	45	45	45

Physical Data (continued)

TABLE 1 – PHYSICAL DATA – MODELS 75-95

MODEL SIZE	075	080	085	090	095
GENERAL DATA					
Length (cm) w/o Hood	1140	1140	1140	1240	1240
Width (cm) w/o Hood	234	234	234	234	234
Height (cm)	208	208	208	234	234
Operating Weights (Kg) (Base Unit, No Options)					
Cooling Only (Rigging & R407C)	5897	5994	6092	6496	6594
Option Weights (Kg)					
Power Exhaust (Blower, Motor, Fan Skid & Mod Damper)	341	341	341	347	347
Power Exhaust (Blower, Motor, Fan Skid, VFD & Baro Damper)	332	332	332	337	337
100% AMS (Measurement Station & Mounting)	57	57	57	64	64
25/75% AMS (Measurement Station & Mounting)	66	66	66	73	73
Min. AMS (Measurement Station & Mounting)	20	20	20	23	23
Barometric Only	20	20	20	25	25
375 MBH Gas Heat	73	73	73	73	73
750 MBH Gas Heat	147	147	147	147	147
1125 MBH Gas Heat	220	220	220	220	220
40 kW	204	204	204	222	222
80 kW	231	231	231	249	249
108 kW	213	213	213	231	231
150 kW	222	222	222	240	240
200 kW	231	231	231	249	249
250 kW	240	240	240	259	259
Condenser Wire Guard	18	18	18	20	20
Copper Condenser Coils (Additional)	280	480	480	540	540
Copper Evaporator Coils (Additional)	209	127	209	209	263
Roof Curb Weights (Kg)					
14" Full Perimeter Roof Curb	463	463	463	472	472
14" Open Condenser Roof Curb	262	262	262	279	279
Compressor Data					
Quantity/Size (Nominal Hp)	4x10, 2x13	6x13	6x13	2x13, 4x15	2x13, 4x15
Type	Scroll	Scroll	Scroll	Scroll	Scroll
Capacity Steps (%)	4x15, 2x20	6x16	6x16	4x18, 2x15	4x18, 2x15
Supply Fan and Drive					
Quantity	1	1	1	1	1
Type	FC	FC	FC	FC	FC
Size	28-25	28-25	28-25	28-28	28-28
Motor Size Range (Min. to Max. Hp)	7.5-60	7.5-60	7.5-60	7.5-60	7.5-60
Air Flow Range (Min. to Max. m3/hr)	23785-54,367	23785-54,367	30582-61164	30582-61164	30582-61164
Static Pressure Range (Min. to Max. ESP)	0-995 Pa	0-995 Pa	0-995 Pa	0-995 Pa	0-995 Pa
Exhaust Fan					
Quantity	2	2	2	2	2
Type	FC	FC	FC	FC	FC
Size	18-18	18-18	18-18	18-18	18-18
Motor Size Range (Min. to Max. HP)	10-20	10-20	10-20	10-20	10-20
Air Flow Range (Min. to Max. m3/hr)	0-33980	0-33980	0-33980	0-33980	0-33980
Static Pressure Range (Min. to Max. ESP)	0-498 Pa	0-498 Pa	0-498 Pa	0-498 Pa	0-498 Pa

TABLE 1 – PHYSICAL DATA – MODELS 75-95 (CONT'D)

MODEL SIZE	075	080	085	090	095
Evaporator Coil					
Size (Square Meters)	5	5	5	5	5
Number of Rows/Fins per cm	1	1	1	1	1
Tube Diameter (cm) /Surface	5/4 /enhanced	5/4 /enhanced	5/4 /enhanced	5/4 /enhanced	5/4 /enhanced
Condenser Coil (Aluminum Fins)					
Size (Square Meters)	17	17	17	17	17
Number of Rows/Fins per cm	0	0	0	0	0
Tube Diameter (cm)	1	1	1	1	1
Condenser Coil (Copper Fins - Opt)					
Size (Square Meters)	17	17	17	17	17
Number of Rows/Fins per cm	0	0	0	0	0
Tube Diameter	1	1	1	1	1
Condenser Fans					
Quantity	6	6	6	6	6
Type	Prop.	Prop.	Prop.	Prop.	Prop.
Diameter (Meters)	1	1	1	1	1
Power (Hp Each)	2	2	2	2	2
Filters - 5.08cm Throwaway					
Quantity	10 / 15	10 / 15	10 / 15	12 / 18	12 / 18
Size (Length x Width) (Meters)	.6x.4 / .6x.5	.6x.4 / .6x.5	.6x.4 / .6x.5	.6x.4 / .6x.5	.6x.4 / .6x.5
Total Filter Face Area (Square Meters)	7	7	7	9	9
Filters - 5.08cm Cleanable					
Quantity	10 / 15	10 / 15	10 / 15	12 / 18	12 / 18
Size (Length x Width) (Meters)	.6x.4 / .6x.5	.6x.4 / .6x.5	.6x.4 / .6x.5	.6x.4 / .6x.5	.6x.4 / .6x.5
Total Filter Face Area (Square Meters)	7	7	7	9	9
Filters - 5.08cm Pleated (30% Efficient)					
Quantity	10 / 15	10 / 15	10 / 15	12 / 18	12 / 18
Size (Length x Width) (Meters)	.6x.4 / .6x.5	.6x.4 / .6x.5	.6x.4 / .6x.5	.6x.4 / .6x.5	.6x.4 / .6x.5
Total Filter Face Area (Square Meters)	7	7	7	9	9
Filters -30.48cm Rigid 65%, 5.08cm 30% Prefilter					
Quantity	2 / 8 / 9	2 / 8 / 9	2 / 8 / 9	8 / 12	8 / 12
Size (Length x Width) (Meters)	.4x.5 / .6x.4 / .6x.5	.4x.5 / .6x.4 / .6x.5	.4x.5 / .6x.4 / .6x.5	.6x.4 / .6x.5	.6x.4 / .6x.5
Total Filter Face Area (Square Meters)	1	1	1	2	2
Filters -30.48cm Rigid 95%, 5.08cm 30% Prefilter					
Quantity	2 / 8 / 9	2 / 8 / 9	2 / 8 / 9	8 / 12	8 / 12
Size (Length x Width) (Meters)	.4x.5 / .6x.4 / .6x.5	.4x.5 / .6x.4 / .6x.5	.4x.5 / .6x.4 / .6x.5	.6x.4 / .6x.5	.6x.4 / .6x.5
Total Filter Face Area (Square Meters)	1	1	1	2	2
Filters - 5.08cm Carbon (30% Efficient)					
Quantity	10 / 15	10 / 15	10 / 15	12 / 18	12 / 18
Size (Length x Width) (Meters)	.6x.4 / .6x.5	.6x.4 / .6x.5	.6x.4 / .6x.5	.6x.4 / .6x.5	.6x.4 / .6x.5
Total Filter Face Area (Square Meters)	2	2	2	2	2
Minimum OA Temp. for Mech. Cig.	45	45	45	45	45

Cooling Performance Data – 50 Ton Model

TABLE 2 – COOLING PERFORMANCE DATA* – 50 TON MODEL

29.4°C AIR ON CONDENSER COIL

m ³ /hr	ENTERING WB (°C)	CAPACITY (kW) AT ENTERING DRY BULB (°C)											
		32		30		28		27		25		23	
		CAP	SHC	CAP	SHC	CAP	SHC	CAP	SHC	CAP	SHC	CAP	SHC
22653	22	189	141	188	125	187	111	186	99	186	86	–	–
	19	179	162	175	148	173	134	173	121	171	108	170	96
	17	179	179	170	172	164	169	160	156	156	143	157	125
25485	22	190	143	189	126	188	112	187	100	187	86	–	–
	19	180	165	175	150	173	135	173	122	172	109	171	97
	17	180	180	172	174	166	168	161	153	157	140	158	122
29733	22	191	146	190	128	189	113	188	101	187	87	–	–
	19	181	168	176	152	175	138	174	124	173	110	172	97
	17	181	181	173	176	167	164	162	150	158	137	159	119
31148	22	196	156	193	134	193	119	192	104	191	89	–	–
	19	186	184	181	163	180	147	179	130	178	115	176	100
	17	189	189	181	183	175	179	167	158	165	144	164	126

* Rated performance is at sea level. Cooling capacities are gross cooling capacity.

35°C AIR ON CONDENSER COIL

m ³ /hr	ENTERING WB (°C)	CAPACITY (kW) AT ENTERING DRY BULB (°C)											
		32		30		28		27		25		23	
		CAP	SHC	CAP	SHC	CAP	SHC	CAP	SHC	CAP	SHC	CAP	SHC
22653	22	182	138	181	121	180	108	180	96	179	83		
	19	173	159	170	146	167	131	167	118	165	107	164	93
	17	173	173	166	167	159	150	156	140	153	128	153	114
25485	22	183	140	182	123	181	109	180	97	180	84	–	–
	19	174	162	171	148	168	133	168	119	166	107	165	94
	17	175	175	167	169	160	152	157	142	154	130	154	115
29733	22	184	143	183	124	182	110	181	97	180	84	–	–
	19	175	165	171	150	169	135	169	120	167	107	166	94
	17	177	177	169	171	162	155	158	144	155	132	155	117
31148	22	188	153	187	132	186	116	185	101	184	87	–	–
	19	182	182	175	159	174	144	173	128	171	109	170	97
	17	184	184	176	178	169	169	162	153	159	140	159	125

* Rated performance is at sea level. Cooling capacities are gross cooling capacity.

TABLE 2 – COOLING PERFORMANCE DATA* – 50 TON MODEL (CONT'D)**40.5°C AIR ON CONDENSER COIL**

m ³ /hr	ENTERING WB (°C)	CAPACITY (kW) AT ENTERING DRY BULB (°C)											
		32		30		28		27		25		23	
		CAP	SHC	CAP	SHC	CAP	SHC	CAP	SHC	CAP	SHC	CAP	SHC
22653	22	175	136	175	119	174	105	173	93	173	80	–	–
	19	164	154	162	142	160	128	160	114	160	102	159	90
	17	168	168	161	163	150	147	150	135	148	126	147	111
25485	22	176	138	176	120	174	106	174	94	173	81	–	–
	19	165	156	163	144	161	130	161	115	161	103	160	90
	17	169	169	162	164	152	149	151	137	149	127	148	113
29733	22	177	140	176	122	175	108	175	95	174	81	–	–
	19	167	160	164	146	162	132	162	117	162	104	161	91
	17	171	171	164	166	154	152	152	140	150	129	149	114
31148	22	181	149	180	129	179	113	178	98	177	83	–	–
	19	175	177	169	157	167	141	166	125	165	109	164	94
	17	179	179	171	173	163	164	155	151	153	137	152	120

* Rated performance is at sea level. Cooling capacities are gross cooling capacity.

46.1°C AIR ON CONDENSER COIL

m ³ /hr	ENTERING WB (°C)	CAPACITY (kW) AT ENTERING DRY BULB (°C)											
		32		30		28		27		25		23	
		CAP	SHC	CAP	SHC	CAP	SHC	CAP	SHC	CAP	SHC	CAP	SHC
22653	22	168	133	167	115	165	101	164	90	163	78		
	19	159	153	155	138	154	126	152	112	151	99	151	87
	17	161	161	154	156	145	147	142	132	140	123	139	109
25485	22	169	135	168	116	166	102	165	90	164	78	–	–
	19	160	156	156	140	154	127	153	113	152	100	151	87
	17	163	163	155	157	147	149	143	135	140	124	139	110
29733	22	170	137	169	118	167	104	166	91	165	79	–	–
	19	162	158	157	142	155	129	154	114	153	101	152	88
	17	165	165	157	158	149	151	144	138	142	126	140	111
31148	22	174	147	172	125	171	109	170	95	169	80	–	–
	19	169	172	160	151	160	137	159	121	158	106	156	91
	17	172	172	163	165	157	160	150	150	146	134	145	118

* Rated performance is at sea level. Cooling capacities are gross cooling capacity.

Cooling Performance Data – 55 Ton Model

TABLE 3 – COOLING PERFORMANCE DATA* – 55 TON MODEL

29.4°C AIR ON CONDENSER COIL

m3/hr	ENTERING WB (°C)	CAPACITY (kW) AT ENTERING DRY BULB (°C)											
		32		30		28		27		25		23	
		CAP	SHC	CAP	SHC	CAP	SHC	CAP	SHC	CAP	SHC	CAP	SHC
20388	22	197	148	197	130	196	116	195	103	194	89	–	–
	19	185	167	181	153	181	139	182	125	180	113	178	100
	17	183	183	175	178	166	171	167	147	166	136	166	123
27184	22	202	159	201	138	201	123	200	107	198	92	–	–
	19	192	186	186	166	186	150	186	134	185	119	183	104
	17	193	193	185	187	177	174	173	159	171	146	171	131
32706	22	209	175	207	150	207	132	206	113	204	96	–	–
	19	202	211	193	183	193	164	192	145	192	127	190	109
	17	206	206	197	199	190	195	180	176	178	159	177	141
33980	22	210	177	208	151	208	133	206	114	205	96	–	–
	19	204	213	194	185	193	166	193	147	193	128	191	110
	17	208	208	199	201	192	197	181	178	179	161	178	143

* Rated performance is at sea level. Cooling capacities are gross cooling capacity.

35°C AIR ON CONDENSER COIL

m3/hr	ENTERING WB (°C)	CAPACITY (kW) AT ENTERING DRY BULB (°C)											
		32		30		28		27		25		23	
		CAP	SHC	CAP	SHC	CAP	SHC	CAP	SHC	CAP	SHC	CAP	SHC
20388	22	190	145	190	126	189	113	189	100	187	87	–	–
	19	178	162	175	150	175	136	175	122	174	113	173	97
	17	178	178	171	173	163	167	162	145	161	133	160	119
27184	22	195	156	194	135	193	120	193	107	192	89	–	–
	19	186	182	180	162	179	147	179	131	178	113	177	101
	17	188	188	180	182	172	170	167	156	165	143	165	128
32706	22	201	171	200	148	199	129	198	129	197	92	–	–
	19	197	205	187	178	186	162	185	143	184	122	183	106
	17	200	200	192	194	184	189	173	171	171	157	171	140
33980	22	202	173	201	149	200	130	199	132	198	92	–	–
	19	198	207	187	180	187	164	186	144	185	123	184	107
	17	202	202	193	196	185	190	174	173	172	158	172	142

* Rated performance is at sea level. Cooling capacities are gross cooling capacity.

TABLE 3 – COOLING PERFORMANCE DATA* – 55 TON MODEL (CONT'D)**40.5°C AIR ON CONDENSER COIL**

m3/hr	ENTERING WB (°C)	CAPACITY (kW) AT ENTERING DRY BULB (°C)											
		32		30		28		27		25		23	
		CAP	SHC	CAP	SHC	CAP	SHC	CAP	SHC	CAP	SHC	CAP	SHC
20388	22	177	139	175	120	174	106	173	94	172	80	–	–
	19	166	159	164	144	162	130	161	116	161	104	161	91
	17	166	166	160	162	152	151	149	137	147	127	146	113
27184	22	182	150	181	130	180	115	180	105	178	84	–	–
	19	175	174	169	157	168	141	167	125	165	111	165	96
	17	177	177	170	172	162	164	156	153	154	137	153	121
32706	22	193	166	193	144	193	127	191	128	190	90	–	–
	19	191	200	181	176	180	159	179	140	175	121	177	104
	17	195	195	186	188	179	184	167	174	165	153	164	135
33980	22	195	168	194	146	194	128	193	131	192	91	–	–
	19	194	202	183	179	181	161	181	142	177	123	178	105
	17	197	197	188	190	182	187	169	176	167	156	166	137

* Rated performance is at sea level. Cooling capacities are gross cooling capacity.

46.1°C AIR ON CONDENSER COIL

m3/hr	ENTERING WB (°C)	CAPACITY (kW) AT ENTERING DRY BULB (°C)											
		32		30		28		27		25		23	
		CAP	SHC	CAP	SHC	CAP	SHC	CAP	SHC	CAP	SHC	CAP	SHC
20388	22	177	139	175	119	174	106	173	94	172	80	–	–
	19	166	158	164	144	161	130	161	115	161	104	160	91
	17	166	166	160	162	152	151	149	137	147	126	146	113
27184	22	181	150	179	129	178	113	177	98	176	83	–	–
	19	173	173	166	154	165	140	165	124	164	110	164	95
	17	175	175	166	168	160	162	155	152	152	136	151	121
32706	22	185	165	185	141	183	122	184	105	181	87	–	–
	19	184	192	170	169	171	154	171	136	169	118	168	100
	17	187	187	175	176	172	177	164	172	158	150	157	131
33980	22	186	167	185	143	184	123	185	106	182	87	–	–
	19	185	193	171	171	172	156	172	137	170	119	169	101
	17	189	189	176	178	173	178	165	173	159	151	158	133

* Rated performance is at sea level. Cooling capacities are gross cooling capacity.

Cooling Performance Data – 60 Ton Model

TABLE 4 – COOLING PERFORMANCE DATA* – 60 TON MODEL

29.4°C AIR ON CONDENSER COIL

m3/hr	ENTERING WB (°C)	CAPACITY (kW) AT ENTERING DRY BULB (°C)											
		32		30		28		27		25		23	
		CAP	SHC	CAP	SHC	CAP	SHC	CAP	SHC	CAP	SHC	CAP	SHC
23786	22	224	170	223	150	222	119	221	117	219	101	–	–
	19	213	199	205	177	205	147	204	144	204	129	202	113
	17	209	209	200	203	196	169	189	175	186	160	187	139
30582	22	232	192	229	165	229	138	228	125	226	106	–	–
	19	224	225	213	199	213	173	212	160	212	141	210	121
	17	225	225	215	218	208	202	198	192	196	180	195	170
35679	22	238	208	234	176	233	156	232	131	231	110	–	–
	19	232	242	219	215	219	195	218	171	217	149	215	126
	17	237	237	226	228	217	224	204	205	203	199	201	195
38228	22	239	213	235	178	234	161	233	133	232	111	–	–
	19	234	244	221	219	220	201	219	174	219	151	216	127
	17	239	239	229	231	220	226	206	208	205	204	203	202

* Rated performance is at sea level. Cooling capacities are gross cooling capacity.

35°C AIR ON CONDENSER COIL

m3/hr	ENTERING WB (°C)	CAPACITY (kW) AT ENTERING DRY BULB (°C)											
		32		30		28		27		25		23	
		CAP	SHC	CAP	SHC	CAP	SHC	CAP	SHC	CAP	SHC	CAP	SHC
23786	22	216	167	214	146	213	126	213	113	211	98	–	–
	19	208	186	199	160	198	154	197	141	196	127	195	110
	17	204	204	195	197	188	179	184	168	182	153	183	135
30582	22	223	188	221	162	220	139	219	122	218	103	–	–
	19	218	216	210	182	206	173	205	156	203	133	202	117
	17	219	219	209	211	201	199	192	187	187	179	184	169
35679	22	229	204	226	174	225	151	223	129	222	107	–	–
	19	225	235	218	210	212	191	210	167	208	142	207	123
	17	229	229	219	222	210	216	198	201	191	198	185	192
38228	22	230	208	227	177	226	155	225	130	223	108	–	–
	19	227	236	221	217	213	196	211	170	209	144	208	124
	17	232	232	222	224	213	219	199	205	192	202	186	195

* Rated performance is at sea level. Cooling capacities are gross cooling capacity.

TABLE 4 – COOLING PERFORMANCE DATA* – 60 TON MODEL (CONT'D)**40.5°C AIR ON CONDENSER COIL**

m3/hr	ENTERING WB (°C)	CAPACITY (kW) AT ENTERING DRY BULB (°C)											
		32		30		28		27		25		23	
		CAP	SHC	CAP	SHC	CAP	SHC	CAP	SHC	CAP	SHC	CAP	SHC
23786	22	208	165	206	143	205	126	205	110	204	94	–	–
	19	200	187	190	171	190	154	190	137	189	122	188	106
	17	197	197	189	191	179	179	177	163	175	150	175	133
30582	22	213	182	212	158	211	139	210	119	209	99	–	–
	19	210	208	198	188	197	172	197	152	195	133	194	114
	17	211	211	202	205	193	197	185	183	180	166	181	147
35679	22	217	195	217	168	216	148	214	125	213	103	–	–
	19	218	227	204	209	203	185	201	163	199	141	198	119
	17	222	222	212	214	204	209	190	197	183	178	185	157
38228	22	218	198	218	171	217	150	215	127	214	104	–	–
	19	220	229	206	217	204	189	202	166	200	144	199	121
	17	224	224	214	217	206	212	192	200	184	181	186	159

* Rated performance is at sea level. Cooling capacities are gross cooling capacity.

46.1°C AIR ON CONDENSER COIL

m3/hr	ENTERING WB (°C)	CAPACITY (kW) AT ENTERING DRY BULB (°C)											
		32		30		28		27		25		23	
		CAP	SHC	CAP	SHC	CAP	SHC	CAP	SHC	CAP	SHC	CAP	SHC
23786	22	199	160	197	138	195	121	194	106	192	91	–	–
	19	187	187	182	169	182	150	181	134	179	118	178	103
	17	190	190	181	183	172	174	167	160	165	147	165	131
30582	22	203	177	203	154	202	134	200	115	199	96	–	–
	19	200	206	190	187	188	168	188	149	186	130	185	110
	17	204	204	192	194	186	190	179	182	173	162	173	144
35679	22	206	190	207	166	206	143	205	121	204	100	–	–
	19	210	219	195	200	193	180	193	159	191	138	190	115
	17	214	214	200	202	197	202	188	196	178	173	178	154
38228	22	207	193	208	169	208	145	206	123	205	100	–	–
	19	213	222	197	204	194	184	194	162	192	140	191	117
	17	216	216	202	204	199	205	190	199	179	176	180	156

* Rated performance is at sea level. Cooling capacities are gross cooling capacity.

Cooling Performance Data – 65 Ton Model

TABLE 5 – COOLING PERFORMANCE DATA* – 65 TON MODEL

29.4°C AIR ON CONDENSER COIL

m3/hr	ENTERING WB (°C)	CAPACITY (kW) AT ENTERING DRY BULB (°C)											
		32		30		28		27		25		23	
		CAP	SHC	CAP	SHC	CAP	SHC	CAP	SHC	CAP	SHC	CAP	SHC
23786	22	226	172	226	150	225	134	224	118	223	102	–	–
	19	215	196	209	179	208	162	208	146	207	130	206	114
	17	211	211	202	205	193	186	194	172	192	159	192	143
30582	22	235	193	233	166	232	147	231	127	230	108	–	–
	19	225	226	217	201	217	182	216	161	215	142	214	122
	17	227	227	218	220	209	210	202	193	200	176	199	157
35679	22	240	206	238	177	237	155	236	133	234	111	–	–
	19	234	244	223	216	222	194	221	171	220	149	218	128
	17	238	238	227	224	219	215	208	196	205	177	204	155
38228	22	241	210	239	180	238	157	237	134	236	112	–	–
	19	236	246	224	219	223	197	222	173	221	151	220	129
	17	240	240	230	213	222	194	209	173	206	154	205	132

* Rated performance is at sea level. Cooling capacities are gross cooling capacity.

35°C AIR ON CONDENSER COIL

m3/hr	ENTERING WB (°C)	CAPACITY (kW) AT ENTERING DRY BULB (°C)											
		32		30		28		27		25		23	
		CAP	SHC	CAP	SHC	CAP	SHC	CAP	SHC	CAP	SHC	CAP	SHC
23786	22	218	168	217	147	217	131	216	115	214	99	–	–
	19	210	193	201	175	201	159	201	142	200	127	199	111
	17	205	205	197	199	188	182	187	169	185	156	184	139
30582	22	226	189	224	163	224	143	223	123	221	104	–	–
	19	218	220	209	197	209	178	208	157	207	138	206	119
	17	221	221	211	214	203	204	195	189	193	173	192	154
35679	22	231	203	229	173	228	151	227	129	225	108	–	–
	19	227	237	214	212	214	190	212	167	211	146	210	124
	17	231	231	220	221	212	217	200	202	197	184	196	162
38228	22	232	206	230	176	229	153	228	131	226	109	–	–
	19	229	239	216	215	215	193	214	170	212	148	211	125
	17	233	233	221	218	215	216	201	203	199	185	198	162

* Rated performance is at sea level. Cooling capacities are gross cooling capacity.

TABLE 5 – COOLING PERFORMANCE DATA* – 65 TON MODEL (CONT'D)

40.5°C AIR ON CONDENSER COIL

m3/hr	ENTERING WB (°C)	CAPACITY (kW) AT ENTERING DRY BULB (°C)											
		32		30		28		27		25		23	
		CAP	SHC	CAP	SHC	CAP	SHC	CAP	SHC	CAP	SHC	CAP	SHC
23786	22	210	165	209	143	208	127	207	111	206	95	–	–
	19	202	189	194	172	193	155	193	138	192	123	191	107
	17	199	199	190	193	181	179	180	165	178	152	177	135
30582	22	217	186	215	159	215	140	214	120	212	100	–	–
	19	210	213	202	194	200	174	200	154	198	135	197	115
	17	214	214	204	207	196	199	187	185	185	169	184	149
35679	22	222	199	219	169	219	148	218	126	216	104	–	–
	19	219	229	207	207	205	186	204	164	202	142	201	120
	17	223	223	213	215	205	211	192	198	189	180	188	158
38228	22	223	203	220	172	220	150	219	127	217	105	–	–
	19	222	231	209	211	206	189	205	166	204	144	202	121
	17	225	225	215	218	207	213	193	202	190	183	189	161

* Rated performance is at sea level. Cooling capacities are gross cooling capacity.

46.1°C AIR ON CONDENSER COIL

m3/hr	ENTERING WB (°C)	CAPACITY (kW) AT ENTERING DRY BULB (°C)											
		32		30		28		27		25		23	
		CAP	SHC	CAP	SHC	CAP	SHC	CAP	SHC	CAP	SHC	CAP	SHC
23786	22	201	161	200	139	199	123	198	107	197	91	–	–
	19	194	186	186	168	185	152	185	135	184	120	183	104
	17	191	191	184	187	173	175	172	161	170	148	170	131
30582	22	208	182	206	156	205	136	205	116	203	97	–	–
	19	202	207	192	188	192	170	191	150	190	131	189	111
	17	206	206	195	197	188	192	182	184	177	165	176	145
35679	22	212	195	211	166	209	144	209	122	207	100	–	–
	19	211	220	196	201	196	182	195	159	193	138	192	116
	17	215	215	201	202	197	196	189	186	181	165	180	143
38228	22	213	198	212	169	210	146	210	123	207	101	–	–
	19	214	223	197	205	197	185	196	162	194	140	193	118
	17	217	217	202	199	200	183	191	162	182	142	181	120

* Rated performance is at sea level. Cooling capacities are gross cooling capacity.

Cooling Performance Data – 70 Ton Model

TABLE 6 – COOLING PERFORMANCE DATA* – 70 TON MODEL

29.4°C AIR ON CONDENSER COIL

m3/hr	ENTERING WB (°C)	CAPACITY (kW) AT ENTERING DRY BULB (°C)											
		32		30		28		27		25		23	
		CAP	SHC	CAP	SHC	CAP	SHC	CAP	SHC	CAP	SHC	CAP	SHC
27184	22	238	186	237	162	236	147	235	125	233	106	–	–
	19	223	222	220	194	220	176	220	157	218	139	216	121
	17	226	226	220	219	209	206	206	188	202	171	202	153
33980	22	249	211	246	180	246	162	244	136	242	114	–	–
	19	239	249	234	224	230	199	229	175	227	153	225	131
	17	243	243	240	242	224	230	220	214	212	192	211	170
37378	22	252	224	250	190	249	169	247	140	246	117	–	–
	19	244	255	241	240	234	210	232	183	231	159	229	135
	17	249	249	247	250	229	235	227	226	216	202	214	178
38228	22	253	226	250	191	249	170	248	141	246	118	–	–
	19	245	256	242	242	234	212	233	185	231	160	229	136
	17	250	250	248	251	229	235	229	228	217	204	215	179

* Rated performance is at sea level. Cooling capacities are gross cooling capacity.

35°C AIR ON CONDENSER COIL

m3/hr	ENTERING WB (°C)	CAPACITY (kW) AT ENTERING DRY BULB (°C)											
		32		30		28		27		25		23	
		CAP	SHC	CAP	SHC	CAP	SHC	CAP	SHC	CAP	SHC	CAP	SHC
27184	22	230	183	229	159	228	140	227	122	225	104	–	–
	19	223	218	213	192	212	173	212	153	210	136	209	118
	17	226	226	213	212	208	206	198	184	195	168	195	149
33980	22	240	208	238	177	237	154	236	133	231	109	–	–
	19	239	244	226	221	222	195	221	170	219	149	218	127
	17	243	243	232	235	224	230	212	209	205	189	203	166
37378	22	244	220	241	186	240	161	239	137	234	112	–	–
	19	244	255	233	236	225	206	224	179	222	155	221	131
	17	249	249	239	242	228	235	219	221	208	199	206	173
38228	22	244	222	242	188	240	162	239	138	235	113	–	–
	19	245	256	235	239	226	207	224	180	223	156	221	132
	17	249	249	241	243	229	235	220	224	209	200	207	175

* Rated performance is at sea level. Cooling capacities are gross cooling capacity.

TABLE 6 – COOLING PERFORMANCE DATA* – 70 TON MODEL (CONT'D)**40.5°C AIR ON CONDENSER COIL**

m3/hr	ENTERING WB (°C)	CAPACITY (kW) AT ENTERING DRY BULB (°C)											
		32		30		28		27		25		23	
		CAP	SHC	CAP	SHC	CAP	SHC	CAP	SHC	CAP	SHC	CAP	SHC
27184	22	221	185	220	159	218	139	218	119	216	100	–	–
	19	216	215	205	196	204	174	204	153	202	134	201	114
	17	219	219	205	204	201	199	191	186	187	169	187	149
33980	22	231	203	229	173	227	150	227	129	225	108	–	–
	19	232	242	218	216	213	191	212	167	211	145	209	123
	17	236	235	224	226	216	222	204	204	196	184	195	161
37378	22	234	215	232	182	230	157	230	133	228	111	–	–
	19	237	247	225	231	217	201	215	175	214	151	212	127
	17	241	241	230	233	221	227	211	216	200	194	198	169
38228	22	235	217	232	183	230	158	230	134	228	111	–	–
	19	238	248	226	233	217	203	216	176	214	152	213	128
	17	242	242	232	234	221	228	212	218	201	195	199	170

* Rated performance is at sea level. Cooling capacities are gross cooling capacity.

46.1°C AIR ON CONDENSER COIL

m3/hr	ENTERING WB (°C)	CAPACITY (kW) AT ENTERING DRY BULB (°C)											
		32		30		28		27		25		23	
		CAP	SHC	CAP	SHC	CAP	SHC	CAP	SHC	CAP	SHC	CAP	SHC
27184	22	215	184	213	157	212	138	211	118	209	99	–	–
	19	213	211	202	194	198	172	197	152	196	133	195	113
	17	215	215	202	201	197	195	188	184	183	168	181	148
33980	22	222	200	220	169	219	147	217	125	216	104	–	–
	19	224	234	209	212	205	187	204	163	202	141	201	119
	17	228	228	215	217	209	215	196	200	189	181	187	158
37378	22	225	211	223	178	221	153	220	129	218	107	–	–
	19	229	239	216	226	208	197	206	171	205	147	203	123
	17	233	233	221	224	213	219	202	211	192	190	190	165
38228	22	226	213	223	179	222	154	221	130	219	107	–	–
	19	230	240	217	228	209	199	207	172	205	148	204	124
	17	234	234	222	225	214	220	204	213	193	192	191	167

* Rated performance is at sea level. Cooling capacities are gross cooling capacity.

Cooling Performance Data – 75 Ton Model

TABLE 7 – COOLING PERFORMANCE DATA* – 75 TON MODEL

29.4°C AIR ON CONDENSER COIL

m3/hr	ENTERING WB (°C)	CAPACITY (kW) AT ENTERING DRY BULB (°C)											
		32		30		28		27		25		23	
		CAP	SHC	CAP	SHC	CAP	SHC	CAP	SHC	CAP	SHC	CAP	SHC
27184	22	244	183	233	159	233	141	232	123	230	104	–	–
	19	228	210	217	191	216	174	216	155	215	137	214	119
	17	228	219	215	214	202	201	202	184	200	170	199	151
33980	22	255	211	243	181	242	158	241	136	240	112	–	–
	19	244	237	231	220	227	198	226	174	224	153	223	131
	17	248	238	234	237	217	224	216	209	211	193	209	170
37378	22	259	224	247	191	245	166	244	141	243	116	–	–
	19	252	246	238	234	230	209	229	184	228	160	226	136
	17	255	245	242	245	223	229	224	220	215	205	212	179
38228	22	259	226	247	193	246	168	245	142	243	117	–	–
	19	254	247	239	237	231	212	230	186	228	161	227	136
	17	256	246	243	246	224	230	225	222	216	207	213	180

* Rated performance is at sea level. Cooling capacities are gross cooling capacity.

35°C AIR ON CONDENSER COIL

m3/hr	ENTERING WB (°C)	CAPACITY (kW) AT ENTERING DRY BULB (°C)											
		32		30		28		27		25		23	
		CAP	SHC	CAP	SHC	CAP	SHC	CAP	SHC	CAP	SHC	CAP	SHC
27184	22	235	183	233	159	233	141	232	123	230	104	–	–
	19	220	210	217	191	216	174	216	155	215	137	214	119
	17	224	219	215	214	202	201	202	184	200	170	199	151
33980	22	246	211	243	181	242	158	241	136	240	112	–	–
	19	236	237	231	220	227	198	226	174	224	153	223	131
	17	243	238	234	237	217	224	216	209	211	193	209	170
37378	22	250	224	247	191	245	166	244	141	243	116	–	–
	19	244	246	238	234	230	209	229	184	228	160	226	136
	17	250	245	242	245	223	229	224	220	215	205	212	179
38228	22	250	226	247	193	246	168	245	142	243	117	–	–
	19	245	247	239	237	231	212	230	186	228	161	227	136
	17	251	246	243	246	224	230	225	222	216	207	213	180

* Rated performance is at sea level. Cooling capacities are gross cooling capacity.

TABLE 7 – COOLING PERFORMANCE DATA* – 75 TON MODEL (CONT'D)

40.5°C AIR ON CONDENSER COIL

m3/hr	ENTERING WB (°C)	CAPACITY (kW) AT ENTERING DRY BULB (°C)											
		32		30		28		27		25		23	
		CAP	SHC	CAP	SHC	CAP	SHC	CAP	SHC	CAP	SHC	CAP	SHC
27184	22	226	183	233	159	233	141	232	123	230	104	–	–
	19	219	210	217	191	216	174	216	155	215	137	214	119
	17	219	219	215	214	202	201	202	184	200	170	199	151
33980	22	236	211	243	181	242	158	241	136	240	112	–	–
	19	235	237	231	220	227	198	226	174	224	153	223	131
	17	238	238	234	237	217	224	216	209	211	193	209	170
37378	22	240	224	247	191	245	166	244	141	243	116	–	–
	19	243	246	238	234	230	209	229	184	228	160	226	136
	17	245	245	242	245	223	229	224	220	215	205	212	179
38228	22	241	226	247	193	246	168	245	142	243	117	–	–
	19	244	247	239	237	231	212	230	186	228	161	227	136
	17	246	246	243	246	224	230	225	222	216	207	213	180

* Rated performance is at sea level. Cooling capacities are gross cooling capacity.

46.1°C AIR ON CONDENSER COIL

m3/hr	ENTERING WB (°C)	CAPACITY (kW) AT ENTERING DRY BULB (°C)											
		32		30		28		27		25		23	
		CAP	SHC	CAP	SHC	CAP	SHC	CAP	SHC	CAP	SHC	CAP	SHC
27184	22	217	183	233	159	233	141	232	123	230	104	–	–
	19	212	210	217	191	216	174	216	155	215	137	214	119
	17	212	219	215	214	202	201	202	184	200	170	199	151
33980	22	227	211	243	181	242	158	241	136	240	112	–	–
	19	227	237	231	220	227	198	226	174	224	153	223	131
	17	230	238	234	237	217	224	216	209	211	193	209	170
37378	22	231	224	247	191	245	166	244	141	243	116	–	–
	19	235	246	238	234	230	209	229	184	228	160	226	136
	17	237	245	242	245	223	229	224	220	215	205	212	179
38228	22	231	226	247	193	246	168	245	142	243	117	–	–
	19	236	247	239	237	231	212	230	186	228	161	227	136
	17	238	246	243	246	224	230	225	222	216	207	213	180

* Rated performance is at sea level. Cooling capacities are gross cooling capacity.

Cooling Performance Data – 80 Ton Model

TABLE 8 – COOLING PERFORMANCE DATA* – 80 TON MODEL

29.4°C AIR ON CONDENSER COIL

m3/hr	ENTERING WB (°C)	CAPACITY (kW) AT ENTERING DRY BULB (°C)											
		32		30		28		27		25		23	
		CAP	SHC	CAP	SHC	CAP	SHC	CAP	SHC	CAP	SHC	CAP	SHC
27184	22	265	195	264	172	262	153	261	135	259	116	–	–
	19	248	224	244	204	244	186	243	167	241	149	240	131
	17	251	251	239	233	226	216	225	196	224	182	223	162
30582	22	272	207	270	181	269	160	267	140	266	120	–	–
	19	256	239	250	216	250	196	249	175	247	156	246	136
	17	259	259	251	250	237	236	231	208	230	192	229	171
37378	22	282	228	281	198	279	173	277	150	275	127	–	–
	19	272	268	261	240	260	216	259	191	257	167	255	145
	17	277	277	268	271	253	260	247	236	239	210	238	185
45307	22	290	252	289	216	287	187	285	160	283	133	–	–
	19	293	301	271	265	269	237	268	208	265	180	263	154
	17	298	298	278	281	264	271	267	274	247	230	246	200

* Rated performance is at sea level. Cooling capacities are gross cooling capacity.

35°C AIR ON CONDENSER COIL

m3/hr	ENTERING WB (°C)	CAPACITY (kW) AT ENTERING DRY BULB (°C)											
		32		30		28		27		25		23	
		CAP	SHC	CAP	SHC	CAP	SHC	CAP	SHC	CAP	SHC	CAP	SHC
27184	22	256	192	254	168	253	150	252	131	250	112	–	–
	19	240	220	235	200	235	181	234	163	233	146	231	127
	17	243	243	231	225	226	216	218	193	215	177	215	158
30582	22	262	203	261	176	259	156	258	137	256	117	–	–
	19	247	235	242	212	241	191	240	171	239	152	237	132
	17	251	251	243	241	237	236	224	205	221	187	220	167
37378	22	272	224	271	193	269	169	267	146	265	123	–	–
	19	263	264	252	235	251	211	250	186	248	164	246	140
	17	268	268	259	262	253	260	239	233	230	204	230	181
45307	22	280	247	279	211	277	183	275	156	273	129	–	–
	19	284	296	262	260	259	232	258	202	256	176	254	149
	17	289	289	268	272	263	271	259	270	238	224	237	195

* Rated performance is at sea level. Cooling capacities are gross cooling capacity.

TABLE 8 – COOLING PERFORMANCE DATA* – 80 TON MODEL

40.5°C AIR ON CONDENSER COIL

m3/hr	ENTERING WB (°C)	CAPACITY (kW) AT ENTERING DRY BULB (°C)											
		32		30		28		27		25		23	
		CAP	SHC	CAP	SHC	CAP	SHC	CAP	SHC	CAP	SHC	CAP	SHC
27184	22	247	189	245	164	244	146	242	127	241	109	–	–
	19	235	229	227	196	226	177	226	160	224	142	222	123
	17	237	237	222	216	219	209	210	189	207	173	206	154
30582	22	253	200	251	172	250	153	248	133	246	114	–	–
	19	242	245	233	208	232	187	232	167	230	148	228	128
	17	245	245	233	232	230	228	216	200	213	182	212	162
37378	22	262	221	260	188	259	165	257	142	255	120	–	–
	19	257	269	242	231	241	206	241	182	239	159	237	136
	17	262	262	249	252	245	252	230	227	221	200	221	176
45307	22	270	243	268	206	267	178	265	151	262	126	–	–
	19	277	289	252	255	249	227	248	199	246	171	244	145
	17	282	282	258	261	255	262	249	260	228	219	228	190

* Rated performance is at sea level. Cooling capacities are gross cooling capacity.

46.1°C AIR ON CONDENSER COIL

m3/hr	ENTERING WB (°C)	CAPACITY (kW) AT ENTERING DRY BULB (°C)											
		32		30		28		27		25		23	
		CAP	SHC	CAP	SHC	CAP	SHC	CAP	SHC	CAP	SHC	CAP	SHC
27184	22	237	185	235	161	234	142	233	124	231	105	–	–
	19	235	229	219	194	217	174	216	155	215	138	213	120
	17	237	237	214	209	212	202	202	184	198	169	198	150
30582	22	243	196	241	169	240	148	238	129	236	109	–	–
	19	242	244	224	206	223	184	222	162	220	143	219	124
	17	245	245	225	224	222	220	208	196	204	178	203	158
37378	22	252	216	250	185	249	160	247	138	245	115	–	–
	19	257	269	234	228	232	202	230	177	229	154	227	132
	17	261	261	240	243	236	243	221	222	212	195	212	172
45307	22	259	238	258	202	256	173	255	147	252	121	–	–
	19	277	289	243	251	239	223	238	193	236	166	234	141
	17	282	282	249	252	246	253	239	250	219	213	218	185

* Rated performance is at sea level. Cooling capacities are gross cooling capacity.

Cooling Performance Data – 85 Ton Model

TABLE 9 – COOLING PERFORMANCE DATA* – 85 TON MODEL

29.4°C AIR ON CONDENSER COIL

m3/hr	ENTERING WB (°C)	CAPACITY (kW) AT ENTERING DRY BULB (°C)											
		32		30		28		27		25		23	
		CAP	SHC	CAP	SHC	CAP	SHC	CAP	SHC	CAP	SHC	CAP	SHC
27184	22	277	204	277	180	275	160	274	141	273	121	–	–
	19	260	232	255	213	255	194	255	175	253	156	252	137
	17	258	258	247	239	239	220	236	204	234	190	233	171
30582	22	285	217	284	190	282	169	281	148	279	125	–	–
	19	267	249	263	227	262	206	262	184	260	164	259	143
	17	269	269	260	257	246	235	244	218	241	201	240	180
37378	22	296	242	294	209	293	184	292	159	290	134	–	–
	19	285	280	274	253	273	228	272	202	271	178	269	153
	17	290	290	277	281	264	262	258	247	252	222	250	196
45307	22	306	269	303	229	302	200	300	170	298	142	–	–
	19	309	315	284	281	283	252	281	221	279	192	277	164
	17	314	314	289	293	287	292	276	283	261	245	258	214

* Rated performance is at sea level. Cooling capacities are gross cooling capacity.

35°C AIR ON CONDENSER COIL

m3/hr	ENTERING WB (°C)	CAPACITY (kW) AT ENTERING DRY BULB (°C)											
		32		30		28		27		25		23	
		CAP	SHC	CAP	SHC	CAP	SHC	CAP	SHC	CAP	SHC	CAP	SHC
27184	22	267	200	267	176	266	157	264	137	263	117	–	–
	19	250	229	246	209	246	190	245	171	244	152	243	133
	17	249	249	240	232	232	224	228	201	225	185	225	166
30582	22	275	213	273	186	272	165	271	144	269	122	–	–
	19	257	245	254	222	253	202	252	180	251	160	249	139
	17	259	259	252	250	239	238	235	214	232	196	231	175
37378	22	286	237	284	204	283	180	281	155	279	130	–	–
	19	275	276	265	248	263	223	262	197	261	173	259	149
	17	279	279	269	272	256	263	249	243	242	216	241	191
45307	22	295	264	292	224	291	195	289	166	287	138	–	–
	19	297	310	274	275	273	247	270	215	269	187	267	159
	17	302	302	281	284	279	287	267	278	251	238	249	208

* Rated performance is at sea level. Cooling capacities are gross cooling capacity.

TABLE 9 – COOLING PERFORMANCE DATA* – 85 TON MODEL**40.5°C AIR ON CONDENSER COIL**

m3/hr	ENTERING WB (°C)	CAPACITY (kW) AT ENTERING DRY BULB (°C)											
		32		30		28		27		25		23	
		CAP	SHC	CAP	SHC	CAP	SHC	CAP	SHC	CAP	SHC	CAP	SHC
27184	22	257	196	256	172	255	153	254	133	252	114	–	–
	19	241	223	237	204	236	185	236	166	234	148	233	129
	17	239	239	233	225	232	223	219	196	217	181	216	162
30582	22	264	209	263	181	262	161	261	140	259	118	–	–
	19	248	239	244	217	242	196	242	175	241	155	240	135
	17	249	249	244	242	239	238	226	209	223	192	222	170
37378	22	275	233	273	199	272	175	270	151	268	126	–	–
	19	264	269	254	242	253	218	252	192	250	168	249	144
	17	269	269	261	264	256	263	240	237	233	212	231	186
45307	22	284	258	281	218	280	190	278	161	276	134	–	–
	19	286	299	263	268	262	241	260	210	258	182	257	154
	17	291	291	272	276	279	287	256	268	242	234	239	203

* Rated performance is at sea level. Cooling capacities are gross cooling capacity.

46.1°C AIR ON CONDENSER COIL

m3/hr	ENTERING WB (°C)	CAPACITY (kW) AT ENTERING DRY BULB (°C)											
		32		30		28		27		25		23	
		CAP	SHC	CAP	SHC	CAP	SHC	CAP	SHC	CAP	SHC	CAP	SHC
27184	22	246	191	246	168	245	149	244	129	242	110	–	–
	19	231	219	227	199	226	181	226	162	225	144	224	124
	17	230	230	224	217	224	216	210	191	208	177	207	157
30582	22	253	204	252	177	251	156	250	135	248	114	–	–
	19	238	234	234	212	232	192	232	171	231	151	230	130
	17	240	240	235	233	231	230	216	204	214	187	213	165
37378	22	263	227	262	195	261	170	259	146	257	122	–	–
	19	254	263	244	237	242	212	242	187	240	164	239	140
	17	258	258	251	254	247	254	230	231	223	206	222	181
45307	22	272	252	270	213	269	185	267	156	264	130	–	–
	19	275	287	252	263	251	235	249	204	247	176	246	149
	17	280	280	262	265	270	277	245	256	232	228	229	197

* Rated performance is at sea level. Cooling capacities are gross cooling capacity.

Cooling Performance Data – 90 Ton Model

TABLE 10 – COOLING PERFORMANCE DATA* – 90 TON MODEL

29.4°C AIR ON CONDENSER COIL

m3/hr	ENTERING WB (°C)	CAPACITY (kW) AT ENTERING DRY BULB (°C)											
		32		30		28		27		25		23	
		CAP	SHC	CAP	SHC	CAP	SHC	CAP	SHC	CAP	SHC	CAP	SHC
33980	22	310	233	308	206	307	183	306	161	304	137	–	–
	19	292	272	286	247	286	224	285	200	283	179	282	156
	17	293	293	286	286	269	258	266	239	262	219	262	195
40776	22	322	260	320	228	318	201	317	174	315	146	–	–
	19	311	307	298	277	297	249	296	220	294	195	293	168
	17	317	317	305	308	289	287	281	269	274	243	272	214
45307	22	329	278	325	242	324	211	322	182	320	152	–	–
	19	325	328	305	295	304	265	301	233	300	205	298	175
	17	330	330	314	318	302	305	290	290	280	258	278	225
50970	22	334	292	330	252	328	219	326	188	324	157	–	–
	19	335	345	310	310	308	277	306	242	304	212	302	180
	17	341	341	321	325	313	319	297	305	284	269	282	234

* Rated performance is at sea level. Cooling capacities are gross cooling capacity.

35°C AIR ON CONDENSER COIL

m3/hr	ENTERING WB (°C)	CAPACITY (kW) AT ENTERING DRY BULB (°C)											
		32		30		28		27		25		23	
		CAP	SHC	CAP	SHC	CAP	SHC	CAP	SHC	CAP	SHC	CAP	SHC
33980	22	299	233	298	202	296	179	295	157	293	133	–	–
	19	281	268	277	243	276	220	275	196	273	174	272	152
	17	282	282	277	278	262	263	257	234	253	214	252	191
40776	22	311	260	309	223	307	196	306	169	303	142	–	–
	19	300	302	288	272	287	244	285	215	284	189	282	163
	17	305	305	296	300	280	288	271	264	264	237	263	209
45307	22	317	278	314	237	313	206	311	177	309	148	–	–
	19	313	322	295	291	293	260	291	227	289	199	287	169
	17	318	318	305	309	294	302	280	284	270	252	268	220
50970	22	322	292	318	247	317	214	315	183	313	152	–	–
	19	323	337	300	305	298	272	295	236	293	206	291	175
	17	329	329	312	316	304	313	287	299	274	263	272	229

* Rated performance is at sea level. Cooling capacities are gross cooling capacity.

TABLE 10 – COOLING PERFORMANCE DATA* – 90 TON MODEL (CONT'D)

40.5°C AIR ON CONDENSER COIL

m3/hr	ENTERING WB (°C)	CAPACITY (kW) AT ENTERING DRY BULB (°C)											
		32		30		28		27		25		23	
		CAP	SHC	CAP	SHC	CAP	SHC	CAP	SHC	CAP	SHC	CAP	SHC
33980	22	288	227	286	197	285	174	284	152	282	129	–	–
	19	273	262	266	238	265	215	264	191	263	169	261	147
	17	274	274	269	270	262	263	247	228	243	209	243	186
40776	22	299	254	297	218	295	191	294	165	292	138	–	–
	19	291	295	278	267	276	239	275	210	273	184	271	158
	17	296	296	288	291	280	288	261	257	254	232	253	204
45307	22	305	272	302	231	301	201	299	172	297	143	–	–
	19	304	314	284	285	282	254	280	222	278	193	276	165
	17	309	309	296	300	294	302	269	275	259	247	258	215
50970	22	310	285	306	241	304	209	303	178	300	147	–	–
	19	314	328	289	298	286	265	284	231	282	201	280	170
	17	319	319	303	307	304	312	276	288	264	258	262	223

* Rated performance is at sea level. Cooling capacities are gross cooling capacity.

46.1°C AIR ON CONDENSER COIL

m3/hr	ENTERING WB (°C)	CAPACITY (kW) AT ENTERING DRY BULB (°C)											
		32		30		28		27		25		23	
		CAP	SHC	CAP	SHC	CAP	SHC	CAP	SHC	CAP	SHC	CAP	SHC
33980	22	276	223	274	192	273	170	272	148	270	125	–	–
	19	260	256	255	233	254	210	253	186	252	164	250	143
	17	261	261	259	259	253	253	237	223	233	204	232	181
40776	22	287	249	285	212	283	186	282	159	280	133	–	–
	19	277	287	267	260	265	233	263	204	261	179	260	153
	17	282	282	276	279	271	278	250	252	243	226	242	198
45307	22	293	266	290	225	288	196	287	167	284	138	–	–
	19	289	302	272	278	270	248	268	216	266	188	265	159
	17	294	294	284	288	284	292	258	267	248	240	247	208
50970	22	297	279	294	235	292	203	290	172	288	143	–	–
	19	299	312	277	291	274	260	272	225	270	195	268	164
	17	304	304	291	295	293	302	264	276	252	251	251	216

* Rated performance is at sea level. Cooling capacities are gross cooling capacity.

Cooling Performance Data – 95 Ton Model

TABLE 11 – COOLING PERFORMANCE DATA* – 95 TON MODEL

29.4°C AIR ON CONDENSER COIL

m3/hr	ENTERING WB (°C)	CAPACITY (kW) AT ENTERING DRY BULB (°C)											
		32		30		28		27		25		23	
		CAP	SHC	CAP	SHC	CAP	SHC	CAP	SHC	CAP	SHC	CAP	SHC
33980	22	324	250	323	222	322	197	321	171	319	143	–	–
	19	304	293	298	265	298	241	299	215	297	191	295	159
	17	310	310	298	302	282	272	278	256	275	235	274	203
40776	22	337	271	335	239	334	210	332	182	330	152	–	–
	19	324	317	311	287	311	259	310	231	308	204	306	169
	17	330	330	313	317	299	292	293	280	287	254	285	218
45307	22	343	289	341	253	339	221	338	190	336	158	–	–
	19	339	341	318	306	317	276	316	244	314	214	312	176
	17	344	344	323	327	313	313	303	301	293	270	291	230
50970	22	349	303	346	264	344	230	342	196	340	163	–	–
	19	349	360	323	321	322	289	320	254	319	222	316	181
	17	355	355	330	334	324	330	310	317	298	282	295	238

* Rated performance is at sea level. Cooling capacities are gross cooling capacity.

35°C AIR ON CONDENSER COIL

m3/hr	ENTERING WB (°C)	CAPACITY (kW) AT ENTERING DRY BULB (°C)											
		32		30		28		27		25		23	
		CAP	SHC	CAP	SHC	CAP	SHC	CAP	SHC	CAP	SHC	CAP	SHC
33980	22	312	250	312	217	311	192	309	166	307	139	–	–
	19	293	288	289	261	288	236	288	210	286	186	284	155
	17	298	298	290	293	274	278	268	251	265	230	264	199
40776	22	325	271	323	234	322	205	320	177	318	148	–	–
	19	313	312	301	282	300	254	299	225	297	199	295	164
	17	318	318	304	308	290	293	283	274	277	248	275	213
45307	22	332	289	329	248	327	216	326	185	324	153	–	–
	19	326	335	308	301	306	271	305	238	303	209	301	171
	17	332	332	314	317	304	310	292	295	283	263	280	225
50970	22	337	303	333	259	332	224	330	191	328	158	–	–
	19	337	352	313	316	311	283	309	248	307	216	305	176
	17	342	342	321	325	315	324	299	311	287	275	285	233

* Rated performance is at sea level. Cooling capacities are gross cooling capacity.

TABLE 11 – COOLING PERFORMANCE DATA* – 95 TON MODEL (CONT'D)

40.5°C AIR ON CONDENSER COIL

m3/hr	ENTERING WB (°C)	CAPACITY (kW) AT ENTERING DRY BULB (°C)											
		32		30		28		27		25		23	
		CAP	SHC	CAP	SHC	CAP	SHC	CAP	SHC	CAP	SHC	CAP	SHC
33980	22	305	247	304	214	303	189	301	164	300	137	–	–
	19	288	285	282	258	282	233	281	207	279	183	277	152
	17	293	293	285	288	272	277	262	248	259	227	258	196
40776	22	308	249	307	216	305	191	304	165	302	138	–	–
	19	290	288	285	260	285	236	284	209	282	185	280	154
	17	297	297	289	292	275	281	266	251	263	230	261	198
45307	22	309	250	308	217	307	192	305	166	303	139	–	–
	19	292	289	287	262	286	237	285	210	284	186	282	155
	17	300	300	291	295	278	283	268	254	265	232	264	200
50970	22	310	251	309	218	308	192	306	166	304	139	–	–
	19	293	291	288	263	288	238	287	211	285	187	283	155
	17	302	302	294	297	280	286	271	256	267	234	266	202

* Rated performance is at sea level. Cooling capacities are gross cooling capacity.

46.1°C AIR ON CONDENSER COIL

m3/hr	ENTERING WB (°C)	CAPACITY (kW) AT ENTERING DRY BULB (°C)											
		32		30		28		27		25		23	
		CAP	SHC	CAP	SHC	CAP	SHC	CAP	SHC	CAP	SHC	CAP	SHC
33980	22	293	241	291	209	290	184	289	159	287	132	–	–
	19	275	279	271	252	270	227	269	202	267	177	266	147
	17	280	280	275	278	264	272	251	242	248	221	247	190
40776	22	296	243	294	211	292	185	291	160	289	133	–	–
	19	278	282	274	255	273	230	272	204	270	179	268	149
	17	284	284	279	282	268	275	254	245	252	224	250	193
45307	22	297	244	295	212	294	186	292	161	291	134	–	–
	19	280	283	275	256	274	231	273	205	272	180	270	150
	17	287	287	281	285	271	278	257	248	254	226	253	195
50970	22	298	244	296	213	295	187	293	162	292	134	–	–
	19	281	285	277	257	275	232	275	206	273	181	271	150
	17	289	289	284	287	273	280	259	249	256	228	254	196

* Rated performance is at sea level. Cooling capacities are gross cooling capacity.

Heating Performance Data – Gas/Electric Heat

GAS HEATING

TABLE 12 – GAS HEAT PERFORMANCE DATA

UNIT	GAS INPUT CAPACITY (BTU/HR X 1000)	MAXIMUM OUTPUT CAPACITY (BTU/HR X 1000)	AIRFLOW (m3/hr)		TEMP. RISE (°C)
			MIN.	MAX.	
50-65	375	300	11808	47147	10-40
	750	600	18944	47147	20-50
70-85	375	300	11808	47147	10-40
	750	600	18944	47147	20-50
	1125	900	25740	56619	25-55
90-95	375	300	11808	47147	10-40
	750	600	18944	47147	20-50
	1125	900	25740	56619	25-55

ELECTRIC HEATING

TABLE 13 – ELECTRIC HEAT PERFORMANCE DATA

UNIT	SIZE (kW)	NOMINAL HEATER SIZE (kW)	HEAT CAPACITY (kW)	AIR FLOW MIN (m3/hr)	MAX TEMP RISE (°C)
50-65 Ton	40	40	40037	13,592	16
	80	80	80075	16,990	25
	108	108	108101	20,388	28
	150	150	150140	23,786	34
70-85 Ton	80	80	80075	16,990	25
	108	108	108101	20,388	28
	150	150	150140	23,786	34
	200	200	200187	25,485	42
90-95 Ton	80	80	80075	16,990	25
	108	108	108101	20,388	28
	150	150	150140	23,786	34
	200	200	200187	25,485	42
	250	250	250234	27,184	49

Supply Fan Data

TABLE 14 – 50 THROUGH 65 TON SUPPLY FAN DATA

TOTAL STATIC PRESSURE (Pascals of water column)										
m3/hr	245		373		498		622		747	
STD. AIR	kW	RPM	kW	RPM	kW	RPM	kW	RPM	kW	RPM
16990										
20388			4.0	515	5.1	601	6.3	675		
23786			4.9	516	6.0	588	7.2	657	8.7	730
27184			6.2	528	7.5	597	8.8	662	10.3	727
29733	5.8	466	7.1	537	8.6	603	10.0	665	11.4	724
30582	6.1	470	7.5	540	8.9	605	10.4	666	11.8	723
32706	7.1	483	8.6	551	10.2	614	11.7	673	13.2	729
33980	7.7	491	9.3	558	10.9	619	12.5	677	14.1	732
37378	9.4	511	11.1	575	12.8	633	14.5	688	16.4	741
38228	9.9	517	11.6	579	13.4	637	15.1	692	17.0	744
40776	11.6	535	13.5	595	15.3	651	17.2	704	19.1	754
44174	13.9	559	15.9	616	17.9	669	20.0	720	22.0	768

TABLE 14 – 50 THROUGH 65 TON SUPPLY FAN DATA (CONT'D)

TOTAL STATIC PRESSURE (Pascals of water column)										
m3/hr	871		995		1120		1244		1369	
STD. AIR	kW	RPM	kW	RPM	kW	RPM	kW	RPM	kW	RPM
16990										
20388										
23786	10.4	802								
27184	11.8	789	13.5	851	15.2	908				
29733	12.9	779	14.5	836	16.3	892	18.3	949		
30582	13.3	776	14.9	831	16.7	886	18.7	942	20.7	999
32706	14.8	781	16.5	834	18.0	880	20.2	938	22.2	991
33980	15.7	784	17.4	835	18.8	880	21.1	936	23.0	986
37378	18.2	792	19.9	839	21.7	885	23.4	929	25.3	973
38228	18.9	794	20.7	841	22.4	887	24.2	930	26.1	973
40776	21.1	803	23.0	849	25.0	894	26.6	936	26.8	935
44174	24.0	814	26.2	860	28.4	903				

Supply Fan Data (continued)

TABLE 15 – 70 THROUGH 85 TON SUPPLY FAN DATA

TOTAL STATIC PRESSURE (Pascals of water column)										
m3/hr	245		373		498		622		747	
STD. AIR	kW	RPM	kW	RPM	kW	RPM	kW	RPM	kW	RPM
27184	4.2	397	5.5	467						
30582	5.3	411	6.7	478	8.2	538	9.8	596	11.4	646
33980	6.4	425	7.9	488	9.5	547	11.2	599	13.0	648
37378	7.8	441	9.6	503	11.3	559	14.0	610	14.9	658
40776	9.3	457	11.2	517	14.0	570	16.0	620	16.9	667
44174	11.3	475	13.3	533	15.4	585	17.4	633	19.5	678
45873	12.1	483	14.4	540	16.5	592	18.6	639	2.8	684
47572	13.8	492	15.4	548	17.7	599	19.8	645	22.4	689
50970	15.5	511	18.2	565	2.5	615	22.8	660	25.1	703
54368	17.9	530	2.6	582	23.3	631	25.8	674	28.2	716

TABLE 15 – 70 THROUGH 85 TON SUPPLY FAN DATA (CONT'D)

TOTAL STATIC PRESSURE (Pascals of water column)										
m3/hr	871		995		1120		1244		1369	
STD. AIR	kW	RPM	kW	RPM	kW	RPM	kW	RPM	kW	RPM
27184										
30582										
33980	14.7	696								
37378	16.8	704	18.6	745	2.9	791				
40776	18.9	711	3.0	752	23.7	792	25.3	832	27.9	877
44174	21.6	721	23.8	762	26.0	801	28.3	840	3.8	879
45873	22.9	726	25.1	767	27.4	806	29.7	843	32.2	880
47572	24.3	731	26.5	772	28.8	810	31.2	847	33.7	881
50970	27.5	743.5	29.9	783	32.3	820	34.8	857	37.3	891
54368	3.8	756	33.3	794	35.8	830				

TABLE 16 – 90 THROUGH 95 TON SUPPLY FAN DATA

TOTAL STATIC PRESSURE (Pascals of water column)										
m3/hr	245		373		498		622		747	
STD. AIR	kW	RPM	kW	RPM	kW	RPM	kW	RPM	kW	RPM
30582			6.3	460	7.9	524	9.9	591	12.6	670
33980			7.5	468	9.2	530	11.2	591	13.6	656
37378			8.7	475	1.6	535	12.5	590	14.5	641
40776	8.2	425	1.2	486	12.3	543	14.3	597	16.4	647
44174	9.6	438	11.8	497	13.9	551	16.2	603	18.4	652
47572	11.4	453	13.8	461	16.4	563	18.4	612	2.7	659
50970	13.2	467	15.6	424	18.1	574	2.6	621	23.9	666
53519	14.2	475	16.8	456	19.4	581	21.9	627	24.5	671
54368	15.4	483	17.9	488	2.7	587	23.3	633	25.9	676
57766	17.7	499	2.3	551	23.2	600	26.6	644	28.8	686
61164	2.3	515	23.1	556	26.2	614	29.6	657	32.6	698

TABLE 16 – 90 THROUGH 95 TON SUPPLY FAN DATA (CONT'D)

TOTAL STATIC PRESSURE (Pascals of water column)										
m3/hr	871		995		1120		1244		1369	
STD. AIR	kW	RPM	kW	RPM	kW	RPM	kW	RPM	kW	RPM
30582	15.4	739	17.6	795						
33980	16.6	717	18.7	776	22.2	841	24.5	899		
37378	16.8	695	19.8	756	23.3	821	26.7	880	29.6	930
40776	18.7	697	21.3	749	24.3	804	27.5	856	3.7	907
44174	2.7	698	23.0	742	25.5	786	28.4	832	31.8	884
47572	23.2	705	25.6	748	28.2	789	3.9	832	34.5	877
50970	25.7	711	28.3	753	3.9	792	33.5	831	36.3	869
53519	27.2	715	29.8	757	32.6	796	35.2	834	38.2	872
54368	28.7	719	31.4	760	34.2	799	36.9	838	39.8	874
57766	31.6	727	34.6	767	37.5	806	4.4	844	43.3	879
61164	46.9	737	6.0	776	55.6	814	59.2	850		

Component Static Pressure Drops

TABLE 17 – COMPONENT STATIC PRESSURE DROPS

SIZE	AIR FLOW m3/hr STD. AIR	EVAPORATOR COILS		RETURN AIR OPENING			FILTERS			
		WET	DRY	BOTTOM	FRONT	SIDE	50.1 cm THROWAWAY	50.1 cm CLEANABLE	50.1 cm PLEATED	50.1 cm CARBON
50	16990	24.83	17.59	10.27	14.79	–	13.14	3.48	10.26	20.98
	20388	32.98	23.79	14.79	21.30	–	17.17	5.14	13.69	27.11
	23786	41.93	30.71	20.13	28.99	–	21.53	7.16	17.46	33.66
	27184	51.63	38.32	26.29	37.87	–	26.19	9.52	21.57	40.61
	29733	59.36	44.45	31.45	45.30	–	29.87	11.54	24.85	46.06
	30582	62.02	46.57	33.28	47.93	–	31.13	12.25	25.98	47.92
	33980	73.08	55.46	41.08	59.17	–	36.34	15.35	30.68	55.57
	35679	78.85	60.12	45.29	65.23	–	39.04	17.04	33.14	59.51
	37378	84.78	64.94	49.71	71.59	–	41.80	18.82	35.67	63.53
40776	97.08	75.01	59.16	85.20	–	47.49	22.68	40.92	71.80	
55	20388	42.85	32.25	14.79	21.30	–	17.17	5.14	13.69	27.11
	23786	54.36	41.47	20.13	28.99	–	21.53	7.16	17.46	33.66
	27184	66.81	51.56	26.29	37.87	–	26.19	9.52	21.57	40.61
	30582	80.13	62.47	33.28	47.93	–	31.13	12.25	25.98	47.92
	32706	88.89	69.70	38.06	54.81	–	34.36	14.15	28.88	52.66
	33980	94.29	74.18	41.08	59.17	–	36.34	15.35	30.68	55.57
	37378	109.24	86.66	49.71	71.59	–	41.80	18.82	35.67	63.53
	40776	124.94	99.87	59.16	85.20	–	47.49	22.68	40.92	71.80
60	23786	98.97	61.80	20.13	28.99	–	21.53	7.16	17.46	33.66
	27184	119.00	76.36	26.29	37.87	–	26.19	9.52	21.57	40.61
	30582	140.02	92.01	33.28	47.93	–	31.13	12.25	25.98	47.92
	33980	161.94	108.72	41.08	59.17	–	36.34	15.35	30.68	55.57
	35679	173.23	117.46	45.29	65.23	–	39.04	17.04	33.14	59.51
	37378	184.72	126.44	49.71	71.59	–	41.80	18.82	35.67	63.53
	40776	208.30	145.12	59.16	85.20	–	47.49	22.68	40.92	71.80
	44174	232.64	164.73	69.43	99.99	–	53.42	26.91	46.44	80.34
	45873	245.09	174.87	74.87	107.83	–	56.46	29.18	49.29	84.72
65	23786	92.50	63.35	20.13	28.99	–	21.53	7.16	17.46	33.66
	27184	111.93	78.56	26.29	37.87	–	26.19	9.52	21.57	40.61
	30582	132.43	94.98	33.28	47.93	–	31.13	12.25	25.98	47.92
	33980	153.93	112.56	41.08	59.17	–	36.34	15.35	30.68	55.57
	35679	165.04	121.76	45.29	65.23	–	39.04	17.04	33.14	59.51
	37378	176.38	131.24	49.71	71.59	–	41.80	18.82	35.67	63.53
	40776	199.71	151.00	59.16	85.20	–	47.49	22.68	40.92	71.80
	44174	223.90	171.79	69.43	99.99	–	53.42	26.91	46.44	80.34
	45873	236.29	182.56	74.87	107.83	–	56.46	29.18	49.29	84.72
70	23786	48.97	30.35	11.09	16.83	29.89	15.51	4.44	12.27	24.60
	27184	59.63	37.87	14.48	21.99	39.04	18.87	5.91	15.16	29.68
	30582	70.94	46.03	18.33	27.83	49.41	22.44	7.60	18.26	35.02
	33980	82.86	54.81	22.62	34.36	61.00	26.19	9.52	21.57	40.61
	37378	95.36	64.18	27.38	41.57	73.81	30.12	11.68	25.07	46.43
	40776	108.41	74.14	32.58	49.47	87.84	34.23	14.07	28.76	52.47
	44174	121.99	84.65	38.23	58.06	103.09	38.50	16.70	32.64	58.72
	47572	136.08	95.71	44.34	67.34	119.56	42.92	19.56	36.70	65.16
	50970	150.65	107.30	50.90	77.30	137.25	47.49	22.68	40.92	71.80
75	23786	81.48	49.88	11.09	16.83	29.89	15.51	4.44	12.27	24.60
	27184	97.69	61.74	14.48	21.99	39.04	18.87	5.91	15.16	29.68
	30582	114.63	74.52	18.33	27.83	49.41	22.44	7.60	18.26	35.02
	33980	132.27	88.17	22.62	34.36	61.00	26.19	9.52	21.57	40.61
	37378	150.56	102.67	27.38	41.57	73.81	30.12	11.68	25.07	46.43
	40776	169.45	117.97	32.58	49.47	87.84	34.23	14.07	28.76	52.47
	44174	188.91	134.06	38.23	58.06	103.09	38.50	16.70	32.64	58.72
	47572	208.92	150.90	44.34	67.34	119.56	42.92	19.56	36.70	65.16
	50970	229.44	168.48	50.90	77.30	137.25	47.49	22.68	40.92	71.80

NOTES: * Includes 2" pleated filters. ** Power exhaust pressure drops are for sizing supply fan.

FILTERS			ECONOMIZER	ECONOMIZER		POWERED EXHAUST
RIGID FILTER RACK, NO MEDIA	30.5 cm RIGID, 65%*	30.5 cm RIGID, 95%*	FRESH AIR OPENINGS	MANUAL OR 2-POSITION	0-100% MODULATION	
22.28	52.86	73.78	18.15	6.66	28.17	2.47
29.11	68.66	93.86	26.65	9.59	38.99	3.56
36.51	85.68	115.12	36.90	13.05	51.33	4.85
44.41	103.82	137.45	48.90	17.04	65.12	6.33
50.66	118.11	154.85	59.09	20.39	76.41	7.57
52.79	123.00	160.77	62.70	21.57	80.34	8.01
61.63	143.17	185.01	78.32	26.63	96.95	9.89
66.20	153.60	197.47	86.82	29.36	105.76	10.91
70.88	164.26	210.13	95.78	32.22	114.90	11.97
80.54	186.23	236.08	115.09	38.35	134.19	14.25
29.11	68.66	93.86	26.65	9.59	38.99	3.56
36.51	85.68	115.12	36.90	13.05	51.33	4.85
44.41	103.82	137.45	48.90	17.04	65.12	6.33
52.79	123.00	160.77	62.70	21.57	80.34	8.01
58.26	135.49	175.81	72.25	24.67	90.56	9.17
61.63	143.17	185.01	78.32	26.63	96.95	9.89
70.88	164.26	210.13	95.78	32.22	114.90	11.97
80.54	186.23	236.08	115.09	38.35	134.19	14.25
36.51	85.68	115.12	36.90	13.05	51.33	4.85
44.41	103.82	137.45	48.90	17.04	65.12	6.33
52.79	123.00	160.77	62.70	21.57	80.34	8.01
61.63	143.17	185.01	78.32	26.63	96.95	9.89
66.20	153.60	197.47	86.82	29.36	105.76	10.91
70.88	164.26	210.13	95.78	32.22	114.90	11.97
80.54	186.23	236.08	115.09	38.35	134.19	14.25
90.58	209.05	262.81	136.29	45.00	154.77	16.72
95.74	220.76	276.46	147.59	48.53	165.54	18.03
36.51	85.68	115.12	36.90	13.05	51.33	4.85
44.41	103.82	137.45	48.90	17.04	65.12	6.33
52.79	123.00	160.77	62.70	21.57	80.34	8.01
61.63	143.17	185.01	78.32	26.63	96.95	9.89
66.20	153.60	197.47	86.82	29.36	105.76	10.91
70.88	164.26	210.13	95.78	32.22	114.90	11.97
80.54	186.23	236.08	115.09	38.35	134.19	14.25
90.58	209.05	262.81	136.29	45.00	154.77	16.72
95.74	220.76	276.46	147.59	48.53	165.54	18.03
24.89	58.92	81.53	20.11	13.05	29.78	2.30
30.29	71.37	97.27	26.65	17.04	37.78	3.00
36.00	84.53	113.68	34.17	21.57	46.61	3.80
42.02	98.35	130.74	42.68	26.63	56.24	4.69
48.34	112.81	148.40	52.19	32.22	66.66	5.67
54.92	127.86	166.63	62.70	38.35	77.85	6.75
61.77	143.49	185.41	74.25	45.00	89.79	7.92
68.87	159.68	204.70	86.82	52.19	102.47	9.19
76.21	176.39	224.48	100.43	59.92	115.88	10.55
24.89	58.92	81.53	20.11	13.05	29.78	2.30
30.29	71.37	97.27	26.65	17.04	37.78	3.00
36.00	84.53	113.68	34.17	21.57	46.61	3.80
42.02	98.35	130.74	42.68	26.63	56.24	4.69
48.34	112.81	148.40	52.19	32.22	66.66	5.67
54.92	127.86	166.63	62.70	38.35	77.85	6.75
61.77	143.49	185.41	74.25	45.00	89.79	7.92
68.87	159.68	204.70	86.82	52.19	102.47	9.19
76.21	176.39	224.48	100.43	59.92	115.88	10.55

Component Static Pressure Drops (continued)

TABLE 17 – COMPONENT STATIC PRESSURE DROPS

EVAPORATOR		COILS		RETURN AIR OPENING			FILTERS			
SIZE	AIR FLOW m3/hr STD. AIR	WET	DRY	BOTTOM	FRONT	SIDE	50.1 cm THROWAWAY	50.1 cm CLEANABLE	50.1 cm PLEATED	50.1 cm CARBON
80	27184	56.67	39.61	14.48	21.99	39.04	18.87	5.91	15.16	29.68
	30582	67.46	47.88	18.33	27.83	49.41	22.44	7.60	18.26	35.02
	33980	78.84	56.73	22.62	34.36	61.00	26.19	9.52	21.57	40.61
	37378	90.77	66.14	27.38	41.57	73.81	30.12	11.68	25.07	46.43
	40776	103.24	76.08	32.58	49.47	87.84	34.23	14.07	28.76	52.47
	44174	116.21	86.54	38.23	58.06	103.09	38.50	16.70	32.64	58.72
	47572	129.68	97.50	44.34	67.34	119.56	42.92	19.56	36.70	65.16
	50970	143.61	108.95	50.90	77.30	137.25	47.49	22.68	40.92	71.80
54368	157.99	120.87	57.92	87.95	156.16	52.21	26.04	45.32	78.61	
85	27184	79.18	51.99	14.48	21.99	39.04	18.87	5.91	15.16	29.68
	30582	94.16	62.99	18.33	27.83	49.41	22.44	7.60	18.26	35.02
	33980	109.94	74.78	22.62	34.36	61.00	26.19	9.52	21.57	40.61
	37378	126.48	87.34	27.38	41.57	73.81	30.12	11.68	25.07	46.43
	40776	143.75	100.65	32.58	49.47	87.84	34.23	14.07	28.76	52.47
	44174	161.71	114.67	38.23	58.06	103.09	38.50	16.70	32.64	58.72
	47572	180.33	129.38	44.34	67.34	119.56	42.92	19.56	36.70	65.16
	50970	199.59	144.78	50.90	77.30	137.25	47.49	22.68	40.92	71.80
54368	219.47	160.83	57.92	87.95	156.16	52.21	26.04	45.32	78.61	
90	30582	85.67	56.81	14.31	27.83	39.84	17.17	5.14	13.69	27.11
	33980	100.22	67.40	17.67	34.36	49.19	20.04	6.45	16.17	31.43
	37378	115.49	78.68	21.38	41.57	59.52	23.05	7.90	18.80	35.94
	40776	131.47	90.61	25.44	49.47	70.83	26.19	9.52	21.57	40.61
	44174	148.10	103.18	29.86	58.06	83.13	29.46	11.30	24.47	45.45
	47572	165.37	116.37	34.63	67.34	96.41	32.84	13.24	27.51	50.43
	50970	183.26	130.16	39.75	77.30	110.67	36.34	15.35	30.68	55.57
	54368	201.74	144.53	45.23	87.95	125.92	39.95	17.62	33.97	60.84
57766	220.80	159.48	51.06	99.29	142.15	43.67	20.07	37.39	66.25	
61164	240.40	174.98	57.25	111.31	159.37	47.49	22.68	40.92	71.80	
95	30582	113.26	71.03	14.31	27.83	39.84	17.17	5.14	13.69	27.11
	33980	132.27	84.28	17.67	34.36	49.19	20.04	6.45	16.17	31.43
	37378	152.20	98.37	21.38	41.57	59.52	23.05	7.90	18.80	35.94
	40776	173.00	113.29	25.44	49.47	70.83	26.19	9.52	21.57	40.61
	44174	194.64	129.01	29.86	58.06	83.13	29.46	11.30	24.47	45.45
	47572	217.09	145.49	34.63	67.34	96.41	32.84	13.24	27.51	50.43
	50970	240.30	162.73	39.75	77.30	110.67	36.34	15.35	30.68	55.57
	54368	264.26	180.70	45.23	87.95	125.92	39.95	17.62	33.97	60.84
57766	288.94	199.38	51.06	99.29	142.15	43.67	20.07	37.39	66.25	
61164	314.31	218.76	57.25	111.31	159.37	47.49	22.68	40.92	71.80	

NOTES: * Includes 2" pleated filters. ** Power exhaust pressure drops are for sizing supply fan.

FILTERS			ECONOMIZER FRESH AIR OPENINGS	ECONOMIZER		POWERED EXHAUST**
RIGID FILTER RACK, NO MEDIA	30.5 cm RIGID, 65%*	30.5 cm RIGID, 95%*		MANUAL OR 2-POSITION	0-100% MODULATION	
30.29	71.37	97.27	26.65	17.04	37.78	3.00
36.00	84.53	113.68	34.17	21.57	46.61	3.80
42.02	98.35	130.74	42.68	26.63	56.24	4.69
48.34	112.81	148.40	52.19	32.22	66.66	5.67
54.92	127.86	166.63	62.70	38.35	77.85	6.75
61.77	143.49	185.41	74.25	45.00	89.79	7.92
68.87	159.68	204.70	86.82	52.19	102.47	9.19
76.21	176.39	224.48	100.43	59.92	115.88	10.55
83.78	193.61	244.74	115.09	68.17	130.02	12.00
30.29	71.37	97.27	26.65	17.04	37.78	3.00
36.00	84.53	113.68	34.17	21.57	46.61	3.80
42.02	98.35	130.74	42.68	26.63	56.24	4.69
48.34	112.81	148.40	52.19	32.22	66.66	5.67
54.92	127.86	166.63	62.70	38.35	77.85	6.75
61.77	143.49	185.41	74.25	45.00	89.79	7.92
68.87	159.68	204.70	86.82	52.19	102.47	9.19
76.21	176.39	224.48	100.43	59.92	115.88	10.55
83.78	193.61	244.74	115.09	68.17	130.02	12.00
17.17	73.32	99.72	26.54	14.20	38.99	2.58
20.04	85.30	114.65	33.14	17.53	47.05	3.18
23.05	97.83	130.11	40.52	21.21	55.76	3.85
26.19	110.88	146.06	48.69	25.24	65.12	4.58
29.46	124.42	162.48	57.65	29.62	75.11	5.37
32.84	138.44	179.36	67.41	34.36	85.72	6.23
36.34	152.92	196.66	77.97	39.44	96.95	7.15
39.95	167.84	214.37	89.35	44.87	108.77	8.14
43.67	183.18	232.49	101.55	50.66	121.18	9.19
47.49	198.94	250.99	114.58	56.79	134.19	10.30
17.17	73.32	99.72	26.54	14.20	38.99	2.58
20.04	85.30	114.65	33.14	17.53	47.05	3.18
23.05	97.83	130.11	40.52	21.21	55.76	3.85
26.19	110.88	146.06	48.69	25.24	65.12	4.58
29.46	124.42	162.48	57.65	29.62	75.11	5.37
32.84	138.44	179.36	67.41	34.36	85.72	6.23
36.34	152.92	196.66	77.97	39.44	96.95	7.15
39.95	167.84	214.37	89.35	44.87	108.77	8.14
43.67	183.18	232.49	101.55	50.66	121.18	9.19
47.49	198.94	250.99	114.58	56.79	134.19	10.30

Gas Heat Pressure Drops

TABLE 18 – GAS HEAT PRESSURE DROPS

SIZE	AIR FLOW m3/hr STD. AIR	SIZE (mbh)		
		375	750	1125
50	16990	29.86	62.21	–
	20388	37.33	74.65	–
	23786	42.30	87.09	–
	27184	49.77	99.54	–
	29733	54.74	109.49	–
	30582	54.74	111.98	–
	33980	62.21	124.42	–
	37378	67.19	136.86	–
	38228	69.68	139.35	–
55	20388	37.33	74.65	–
	23786	42.30	87.09	–
	27184	49.77	99.54	–
	30582	54.74	111.98	–
	32706	59.72	119.44	–
	33980	62.21	124.42	–
	37378	67.19	136.86	–
	40776	74.65	149.30	–
	45873	84.61	166.72	–
60	23786	42.30	87.09	–
	27184	49.77	99.54	–
	30582	54.74	111.98	–
	33980	62.21	124.42	–
	35679	64.70	129.40	–
	37378	67.19	136.86	–
	40776	74.65	149.30	–
	44174	79.63	161.75	–
	45873	84.61	166.72	–
65	23786	42.30	87.09	–
	27184	49.77	99.54	–
	30582	54.74	111.98	–
	33980	62.21	124.42	–
	35679	64.70	129.40	–
	37378	67.19	136.86	–
	40776	74.65	149.30	–
	44174	79.63	161.75	–
	45873	84.61	166.72	–
70	27184	39.81	79.63	119.44
	30582	44.79	89.58	134.37
	33980	49.77	99.54	149.30
	37378	54.74	109.49	164.23
	40776	59.72	119.44	179.16
	44174	64.70	129.40	194.10
	45873	67.19	134.37	201.56

SIZE	AIR FLOW m3/hr STD. AIR	SIZE (mbh)		
		375	750	1125
75	27184	39.81	79.63	119.44
	30582	44.79	89.58	134.37
	33980	49.77	99.54	149.30
	37378	54.74	109.49	164.23
	40776	59.72	119.44	179.16
	44174	64.70	129.40	194.10
	45873	67.19	134.37	201.56
	30582	44.79	89.58	134.37
80	33980	49.77	99.54	149.30
	37378	54.74	109.49	164.23
	40776	59.72	119.44	179.16
	44174	64.70	129.40	194.10
	47572	69.68	139.35	209.03
	50970	74.65	149.30	223.96
	54369	79.63	159.26	236.40
85	30582	44.79	89.58	134.37
	33980	49.77	99.54	149.30
	37378	54.74	109.49	164.23
	40776	59.72	119.44	179.16
	44174	64.70	129.40	194.10
	47572	69.68	139.35	209.03
	50970	74.65	149.30	223.96
	54369	79.63	159.26	236.40
90	33980	44.79	87.09	131.89
	37378	47.28	97.05	144.33
	40776	52.26	104.51	159.26
	44174	57.23	114.47	171.70
	47572	62.21	124.42	184.14
	50970	67.19	131.89	199.07
	53519	69.68	139.35	209.03
	54369	69.68	141.84	211.51
	57767	74.65	149.30	223.96
95	61165	79.63	159.26	236.40
	33980	44.79	87.09	137.61
	37378	47.28	97.05	144.33
	40776	52.26	104.51	159.26
	44174	57.23	114.47	171.70
	47572	62.21	124.42	184.14
	50970	67.19	131.89	199.07
	53519	69.68	139.35	209.03
	54369	69.68	141.84	211.51
57767	74.65	149.30	223.96	
61165	79.63	159.26	236.40	



00566VIP

Electric Heat Pressure Drops

TABLE 19 – ELECTRIC HEAT PRESSURE DROPS

	SIZE (kW)	40	80	108	150	250
	VOLT/PHASE/HZ	400/3/50	400/3/50	400/3/50	400/3/50	400/3/50
SIZE	AIR FLOW m3/hr STD. AIR					
50	16990	3.50	5.09	5.09		
	20388	5.04	7.34	7.34		
	23786	6.87	9.99	9.99		
	27184	8.97	13.04	13.04		
	29733	10.73	15.60	15.60		
	30582	11.35	16.51	16.51		
	33980	14.01	20.38	20.38		
	37378	16.95	24.66	24.66		
	38228	17.73	25.79	25.79		
55	40776	20.18	29.35	29.35		
	20388	5.04	7.34	7.34		
	23786	6.87	9.99	9.99		
	27184	8.97	13.04	13.04		
	30582	11.35	16.51	16.51		
	32706	12.98	18.88	18.88		
	33980	14.01	20.38	20.38		
	37378	16.95	24.66	24.66		
60	40776	20.18	29.35	29.35		
	23786	6.87	9.99	9.99		
	27184	8.97	13.04	13.04		
	30582	11.35	16.51	16.51		
	33980	14.01	20.38	20.38		
	35679	15.45	22.47	22.47		
	37378	16.95	24.66	24.66		
	40776	20.18	29.35	29.35		
65	44174	23.68	34.44	34.44		
	45873	25.53	37.14	37.14		
	23786	6.87	9.99	9.99		
	27184	8.97	13.04	13.04		
	30582	11.35	16.51	16.51		
	33980	14.01	20.38	20.38		
	35679	15.45	22.47	22.47		
	37378	16.95	24.66	24.66		
70	40776	20.18	29.35	29.35		
	44174	23.68	34.44	34.44		
	45873	25.53	37.14	37.14		
	27184			10.95	21.22	
	30582			13.86	26.86	
	33980			17.12	33.16	
	37378			20.71	40.12	
	40776			24.65	47.75	
	44174			28.93	56.04	
	47572			31.19	60.44	
50970			33.55	65.00		
50970			38.51	74.61		
47572			33.55	65.00		
50970			38.51	74.61		

TABLE 19 – ELECTRIC HEAT PRESSURE DROPS (CONT'D)

SIZE	SIZE (kW)	40	80	108	150	250
	VOLT/PHASE/HZ	400/3/50	400/3/50	400/3/50	400/3/50	400/3/50
SIZE	AIR FLOW m3/hr STD. AIR					
75	27184		10.95	10.95	21.22	
	30582		13.86	13.86	26.86	
	33980		17.12	17.12	33.16	
	37378		20.71	20.71	40.12	
	40776		24.65	24.65	47.75	
	44174		28.93	28.93	56.04	
	45873		31.19	31.19	60.44	
	47572		33.55	33.55	65.00	
80	50970		38.51	38.51	74.61	
	27184		10.95	10.95	21.22	
	30582		13.86	13.86	26.86	
	33980		17.12	17.12	33.16	
	37378		20.71	20.71	40.12	
	40776		24.65	24.65	47.75	
	44174		28.93	28.93	56.04	
	47572		33.55	33.55	65.00	
85	50970		38.51	38.51	74.61	
	54368		43.82	43.82	84.89	
	27184		10.95	10.95	21.22	
	30582		13.86	13.86	26.86	
	33980		17.12	17.12	33.16	
	37378		20.71	20.71	40.12	
	40776		24.65	24.65	47.75	
	44174		28.93	28.93	56.04	
90	47572		33.55	33.55	65.00	
	50970		38.51	38.51	74.61	
	54368		43.82	43.82	84.89	
	33980		13.19	13.19	25.55	25.55
	37378		15.96	15.96	30.91	30.91
	40776		18.99	18.99	36.79	36.79
	44174		22.28	22.28	43.18	43.18
	47572		25.85	25.85	50.07	50.07
95	50970		29.67	29.67	57.48	57.48
	53519		32.71	32.71	63.38	63.38
	54368		33.76	33.76	65.40	65.40
	57766		38.11	38.11	73.83	73.83
	61164			42.72	82.78	82.78
	33980			13.19	25.55	25.55
	37378			15.96	30.91	30.91
	40776			18.99	36.79	36.79
95	44174			22.28	43.18	43.18
	47572			25.85	50.07	50.07
	50970			29.67	57.48	57.48
	53519			32.71	63.38	63.38
	54368			33.76	65.40	65.40
	57766			38.11	73.83	73.83
	61164			42.72	82.78	82.78

Exhaust Fan Data

EXHAUST FAN MOTOR SIZING INSTRUCTIONS

In order to determine the proper exhaust fan motor size, add the return duct static pressure to the appropriate damper pressure drop value in Table 23 to get the total static pressure applied to the exhaust fan. Based on the exhaust fan air flow and total static pressure, determine the brake horsepower and RPM of the exhaust fan.

TABLE 20 – 50 THROUGH 65 TON EXHAUST FAN DATA

TOTAL STATIC PRESSURE (Pascals of water column)								
m3/hr	62		124		187		249	
STD. AIR	kW	RPM	kW	RPM	kW	RPM	kW	RPM
13592	1.2	498	1.6	598	1.9	675	2.3	744
20388	3.7	694	3.9	732	4.5	804	5.9	867
27184	8.4	906	8.8	930	9.2	957	9.6	996
33980			16.6	1141	17.7	1161		

TABLE 20 – 50 THROUGH 65 TON EXHAUST FAN DATA (CONT'D)

TOTAL STATIC PRESSURE (Pascals of water column)								
m3/hr	311		373		435		478	
STD. AIR	kW	RPM	kW	RPM	kW	RPM	kW	RPM
13592	2.6	810	3.0	873	3.4	933	3.9	992
20388	5.6	924	6.1	976	6.6	1025	7.2	1072
27184	1.4	1055	11.2	1104	12.0	1150	12.7	1196
33980								

NOTE: * Grey areas indicate operation in motor service factor.

TABLE 21 – 70 THROUGH 85 TON EXHAUST FAN DATA

TOTAL STATIC PRESSURE (Pascals of water column)								
m3/hr	62		124		187		249	
STD. AIR	kW	RPM	kW	RPM	kW	RPM	kW	RPM
20388	1.5	432	2.0	517	2.4	583	2.8	641
27184	3.0	516	3.7	593	4.3	658	4.9	713
33980	5.5	610	6.2	672	7.1	733	7.9	788
40776	9.0	710	9.9	760	1.9	812	12.0	864

TABLE 21 – 70 THROUGH 85 TON EXHAUST FAN DATA (CONT'D)

TOTAL STATIC PRESSURE (Pascals of water column)								
m3/hr	311		373		435		478	
STD. AIR	kW	RPM	kW	RPM	kW	RPM	kW	RPM
20388	3.2	694	3.6	744	4.3	792	4.6	839
27184	5.5	762	6.0	807	6.5	850	7.6	890
33980	8.8	837	9.4	881	1.2	921	1.8	959
40776	13.0	912	14.0	956	14.9	997	15.7	1034

TABLE 22 – 90 THROUGH 95 TON EXHAUST FAN DATA

TOTAL STATIC PRESSURE (Pascals of water column)								
m3/hr	62		124		187		249	
STD. AIR	kW	RPM	kW	RPM	kW	RPM	kW	RPM
23786	2.2	474	2.8	555	3.4	621	3.8	677
30582	4.2	563	5.0	633	5.7	696	6.4	751
37378	7.2	660	8.5	716	9.4	773	10.0	826
44174	11.2	761	12.2	807	13.3	855	14.4	904

TABLE 22 – 90 THROUGH 95 TON EXHAUST FAN DATA (CONT'D)

TOTAL STATIC PRESSURE (Pascals of water column)								
m3/hr	311		373		435		478	
STD. AIR	kW	RPM	kW	RPM	kW	RPM	kW	RPM
23786	4.3	728	4.8	776	5.3	821	5.8	865
30582	7.8	800	7.8	844	8.3	886	8.9	925
37378	1.9	875	11.7	919	12.5	959	13.3	997
44174	15.6	950	16.7	994	16.7	994	18.7	1072

Component Static Pressure Drops

TABLE 23 – COMPONENT STATIC PRESSURE DROPS (PASCALS OF WATER COLUMN)

SIZE	AIR FLOW m ³ /hr STD. AIR	2-POSITION OR VFD POWERED EXHAUST (BAROMETRIC DAMPER)	MODULATING EXHAUST (CONTROL DAMPER)
50	13592	4.98	4.98
	16990	7.47	7.47
	20388	9.95	9.95
	23786	12.44	12.44
	27184	17.42	17.42
	30582	19.91	19.91
	33980	24.88	24.88
	37378	29.86	29.86
	40776	37.33	37.33
55	135921	4.98	4.98
	16990	7.47	7.47
	20388	9.95	9.95
	23786	12.44	12.44
	27184	17.42	17.42
	30582	19.91	19.91
	33980	24.88	24.88
	37378	29.86	29.86
	40776	37.33	37.33
60	16990	7.47	7.47
	20388	9.95	9.95
	23786	12.44	12.44
	27184	17.42	17.42
	30582	19.91	19.91
	33980	24.88	24.88
	37378	29.86	29.86
	40776	37.33	37.33
65	16990	7.47	7.47
	20388	9.95	9.95
	23786	12.44	12.44
	27184	17.42	17.42
	30582	19.91	19.91
	33980	24.88	24.88
	37378	29.86	29.86
	40776	37.33	37.33
70	20388	24.88	7.47
	23786	34.84	9.95
	27184	44.79	12.44
	30582	59.72	17.42
	33980	74.65	19.91
	37378	92.07	24.88
	40776	109.49	29.86
	44174	131.89	37.33

TABLE 23 – COMPONENT STATIC PRESSURE DROPS (PASCALS OF WATER COLUMN) (CONT'D)

SIZE	AIR FLOW m3/hr STD. AIR	2-POSITION OR VFD POWERED EXHAUST (BAROMETRIC DAMPER)	MODULATING EXHAUST (CONTROL DAMPER)
75	20388	24.88	24.88
	23786	34.84	34.84
	27184	44.79	44.79
	30582	59.72	59.72
	33980	74.65	74.65
	37378	92.07	92.07
	40776	109.49	109.49
	44174	131.89	131.89
80	20388	24.88	24.88
	23786	34.84	34.84
	27184	44.79	44.79
	30582	59.72	59.72
	33980	74.65	74.65
	37378	92.07	92.07
	40776	109.49	109.49
	44174	131.89	131.89
85	20388	24.88	24.88
	23786	34.84	34.84
	27184	44.79	44.79
	30582	59.72	59.72
	33980	74.65	74.65
	37378	92.07	92.07
	40776	109.49	109.49
	44174	131.89	131.89
90	27184	29.86	29.86
	30582	37.33	37.33
	33980	47.28	47.28
	37378	59.72	59.72
	40776	72.16	72.16
	44174	87.09	87.09
95	27184	29.86	29.86
	30582	37.33	37.33
	33980	47.28	47.28
	37378	59.72	59.72
	40776	72.16	72.16
	44174	87.09	87.09

Electrical Data

ELECTRICAL SERVICE SIZING

In order to use the electrical service required for the cooling only eco² rooftop, use the appropriate calculations listed below from U.L. 1995. Based on the configuration of the rooftop, the calculations will yield different MCA (minimum circuit ampacity), and MOP (maximum overcurrent protection).

Using the following load definitions and calculations, determine the correct electrical sizing for your unit. All concurrent load conditions must be considered in the calculations, and you must use the highest value for any combination of loads.

Load Definitions:

- **LOAD1** is the current of the largest motor – compressor or fan motor.
- **LOAD2** is the sum of the remaining motor currents that may run concurrently with LOAD1.

- **LOAD3** is the current of the electric heaters – zero for cooling only units.
- **LOAD4** is the sum of any remaining currents greater than or equal to 1.0 amp.

Use the following calculations to determine MCA and MOP for units supplied with a single-point power connection:

$$\text{MCA} = (1.25 \times \text{LOAD1}) + \text{LOAD2} + \text{LOAD3} + \text{LOAD4}$$

$$\text{MOP} = (2.25 \times \text{LOAD1}) + \text{LOAD2} + \text{LOAD3} + \text{LOAD4}$$

If the MOP does not equal a standard current rating of an overcurrent protective device, then the marked maximum rating is to be the next lower standard rating. However, if the device selected for MOP is less than the MCA, then select the lowest standard maximum fuse size greater than or equal to the MCA.

TABLE 24 – COMPRESSOR DATA

Model	Compressor		Nominal Voltage	
	Quantity per Unit	Model	400/3/50	
			RLA	LRA
50	4	SZ160	24.2	135
55	4	SZ160	24.2	135
60	4	SZ185	27.9	175
65	4	SZ185	27.9	175
70	4	SZ125	17.9	120
	2	SZ160	24.2	135
75	4	SZ125	17.9	120
	2	SZ160	24.2	135
80	6	SZ160	24.2	135
85	6	SZ160	24.2	135
90	2	SZ160	24.2	135
	4	SZ185	27.9	175
95	2	SZ160	24.2	135
	4	SZ185	27.9	175

**TABLE 25 – SUPPLY AND EXHAUST FAN MOTOR
(ODP OR TEFC)**

MOTOR HP	NOMINAL VOLTAGE
	400/3/50
	FLA
5	8.5
7.5	12.7
10	15.6
15	25.0
20	32.0
25	42.0
30	46.0
40	62.0
50	74.0
60	91.0

TABLE 26 – CONDENSER FAN MOTORS / TOTAL

NOMINAL TONS	NOMINAL VOLTAGE
	400/3/50
	FLA
50	14.4
55	14.4
60	14.4
65	14.4
70	21.6
75	21.6
80	21.6
85	21.6
90	21.6
95	21.6

TABLE 27 – CONTROL TRANSFORMER

DESCRIPTION	NOMINAL VOLTAGE
	400/3/50
	AMPS
YPAL050-065	1.9
YPAL070-095	1.9

TABLE 28 – ELECTRIC HEAT

kW	NOM. VOLTAGE
	400/3/50
	AMPS
40	56
80	111
108	150
150	209
200	279
250	Not Available

CONTROL SEQUENCES COMMON TO ALL UNITS

GENERAL

The control system for the YORK eco² Packaged Rooftop Unit is fully self-contained and based around an OptiLogic™ rooftop unit controller. To aid in unit setup, maintenance, and operation, the OptiLogic™ rooftop unit controller is equipped with a user interface that is based around a 4 line x 20 character backlit LCD display. The LCD displays plain language text in a menu-driven format to facilitate use. In addition to the display, the OptiLogic™ user interface is also equipped with an LED indicator light, which will warn of any abnormal operation of the equipment or communication failures.

For the maximum in system flexibility, the YORK eco² Packaged Rooftop Unit can be operated by either a typical 7-wire thermostat (2 cool/2 heat), a space temperature sensor, or stand-alone (VAV only). Note, a field wiring terminal block is provided to facilitate unit setup and installation.

In lieu of the hard-wired control options, the OptiLogic™ rooftop unit controller can be connected to and operated by a Building Automation System (BAS). If required, the OptiLogic™ rooftop unit controller can be equipped with an optional BACNet IP communication card, which allows communication, via Ethernet, to a BACNet IP based BAS.

UNOCCUPIED / OCCUPIED SWITCHING

Depending on application, the unit can be indexed between unoccupied and occupied modes of operation by one of three methods, hard-wired input, internal time clock, or BAS. A contact-closure input is provided for hard-wiring to an external indexing device such as a central time clock, thermostat with built in scheduling, or a manual switch. The unit controller is also equipped with a built in 7-day time clock which can be used, in lieu of the contact closure input, to switch the unit between Unoccupied and Occupied modes of operation. The internal time clock is fully configurable via the user interface and includes Holiday scheduling. In addition to the hard-wired input or the internal time clock, the unit can also be indexed between unoccupied and occupied modes of operation via a BAS command.

Note a unit operated from a space sensor can be equipped to temporarily override an unoccupied mode of operation. This Unoccupied Override feature is fully configurable via the OptiLogic™ user interface.

GAS HEATING OPERATION

Units supplied with gas heat can be equipped one, two, or three independently operated burner modules. Each module is fully self-contained furnace with all necessary ignition controls, safeties, and gas valves. The OptiLogic rooftop unit controller determines how the furnaces are started and stopped and prevents furnace operation if the Supply Fan airflow is not sufficient or if the Supply Air Temperature is excessively high.

If a furnace module receives a signal to start from the OptiLogic controller, the ignition control engages the furnace inducer (draft) fan for a 30-second pre-purge cycle. At the end of the 30-second pre-purge, the ignition control will stop the furnace and allows the inducer fan to operate for a 30-second post-purge. Each furnace contains a direct spark ignition system and included safeties for flame and inducer fan verification, high temperature and flame roll-out.

MORNING WARM-UP

Morning Warm-Up can be initialized by BAS or by the OptiLogic controller if the Internal Scheduling is used. If the Internal Scheduling is used, the Morning Warm-Up start time is calculated through an adaptive algorithm, which determines the optimum start time.

When Morning Warm-Up is required, the OptiLogic controller starts the Supply Fan and qualifies the Return Air Temperature for 5 minutes. The internal heat source (Gas, HW/Steam, or Electric) is controlled to maintain the Return Air Temperature to the Morning Warm-Up Setpoint, Morning Warm-Up ends when occupancy occurs (BAS, Internal Scheduling, or contact closure), or when the Maximum Morning Warm-Up Time has expired.

ELECTRIC HEATING OPERATION

For units equipped with electric heaters, the unit can control up to six stages of electric heat which are staged on based on heating demand calculates by the OptiLogic controller.

ECONOMIZER OPERATION

The unit can be equipped with one of three types of optional economizers, dry bulb, single enthalpy, or comparative enthalpy. When the unit controller determines that Outside Air is suitable for economizing, the unit controller will control the outside air damper(s) open to provide economizer cooling. If economizer cooling alone is insufficient for the cooling load, the unit controller shall stage up compressors, one at a time, to meet demand.

The control logic for the three types of economizers is as follows:

Dry Bulb Economizer

The dry bulb economizer is the default economizer control scheme. With the dry bulb economizer, the unit controller monitors the Outside Air temperature only and compares it to a reference temperature setting. Outside Air is deemed suitable for economizing when the Outside Air temperature is determined to be less than the reference temperature setting. This method of economizing is effective, but is prone to some change-over inefficiencies due to the fact that this method is based on sensible temperatures only and does not take Outside Air moisture content into consideration.

Single Enthalpy Economizer

With the optional single enthalpy economizer, the unit controller monitors the Outside Air enthalpy in addition to the Outside Air temperature and compares it to a reference enthalpy setting and a reference temperature setting. Outside Air is deemed suitable for economizing when the Outside Air enthalpy is determined to be less than the reference enthalpy setting and the Outside Air temperature is less than the reference temperature setting. This method of economizing allows the reference temperature setting to be set higher than the DB Economizer and is consequently a more efficient packaged rooftop economizer.

Comparative (Dual) Enthalpy Economizer

With the optional comparative enthalpy economizer, the unit controller monitors and compares the Outside Air and Return Air enthalpies in addition to comparing the Outside Air temperature to the reference temperature setting. Outside Air is deemed suitable for economizing when the Outside Air enthalpy is determined to be less than the Return Air enthalpy and the Outside Air temperature is less than the reference temperature setting. This method of economizing is the most accurate and provides the highest degree of energy efficiency for a packaged rooftop economizer.

VENTILATION CONTROL SEQUENCES

Minimum OA Damper Position (CV Units)

When the unit goes into the Occupied mode of operation, the unit controller shall open the Outside Air Damper to a fixed minimum position. The damper shall remain at this position as long as the unit is in the occupied mode, and the economizer is not suitable for cooling.

Minimum OA Damper Position (VAV Units)

With Variable Air Volume units, there are two Minimum OA Damper Positions, one when the unit is at full speed and the second when the unit is at approximately half speed. These two points allow the control to linearly reset the position of the OA damper in response to fan speed.

When the unit goes into the Occupied mode of operation, the unit controller shall monitor the speed of the supply fan and open the Outside Air damper to a calculated minimum position based on the fan speed. This minimum position shall vary as the speed of the fan changes. The damper shall remain at this calculated position as long as the unit is in the occupied mode, and the economizer is not suitable for cooling.

Air Measurement Stations

When the unit is equipped with an air measurement station, the unit controller shall control the Outside Air damper to a measured flow rate through the Air Measurement Station.

When the unit goes into the Occupied mode of operation, the unit controller shall control the Outside Air damper to maintain the Minimum AirFlow Setpoint

Controls (continued)

through the Air Measurement Station. The unit controller shall control the Outside Air damper to this flow rate as long as the unit is in the Occupied mode, and the economizer is not suitable for cooling.

Demand Ventilation

If an optional CO₂ sensor is connected to the unit, the unit controller can reset the minimum OA damper position(s) or minimum flow rate based on demand.

The unit controller shall monitor the CO₂ level within the building. If the CO₂ level rises above the CO₂ setpoint, the controller will temporarily increase the Minimum OA Damper Position or Minimum OA flow rate to increase ventilation. If the CO₂ level drops below the CO₂ setpoint, the controller will decrease the Minimum OA Damper Position or Minimum OA flow rate to decrease ventilation.

Demand Ventilation shall remain active as long as the unit is in the Occupied mode of operation.

EXHAUST CONTROL SEQUENCES

Barometric

The optional barometric exhaust system consists of a lightweight barometric relief damper installed on the end of the unit in the Return Air section. As more outside air is introduced into the controlled zone due to Economizer and Ventilation control sequences, the pressure inside the building rises. This increase in building pressure forces the barometric relief damper open to allow exhaust air to escape. Because this type of exhaust system is not powered, it is limited to small amounts of exhaust.

Powered Fixed Volume Exhaust Based on Outside Air Damper Position

This optional fixed volume powered exhaust system consists of a fixed speed fan that is controlled ON and OFF based on the position of the Outside Air Damper. During operation, when the Outside Air Damper opens to a selected turn-on point, the Exhaust Fan is cycled ON. The fan remains on as long as the Outside Air damper is above a selected turn-off point. If the Outside Air Damper closes to the selected turn-off point, the Exhaust Fan is cycled OFF. The turn-on and turn-off points are user selectable from the OptiLogic™ User Interface panel.

Powered Fixed Volume Exhaust Based on Building Pressure

The optional fixed volume powered exhaust system consists of a fixed speed fan that is controlled ON and

OFF based on the pressure inside the building. During operation, the pressure within the building is monitored by the OptiLogic™ controller. If the pressure rises to or above a selected turn-on pressure, the Exhaust Fan is cycled ON. The fan shall remain on as long as the pressure within the building remains above a selected turn-off pressure. If the building pressure falls to or below the selected turn-off pressure, the Exhaust Fan is cycled OFF. The turn-on and turn-off pressure setpoints are user selectable from the OptiLogic™ User Interface.

Powered Variable Volume Exhaust-Discharge Damper Controlled

This optional variable volume powered exhaust system consists of a fixed speed fan configured with a proportionally controlled discharge damper. The OptiLogic™ controller monitors the pressure inside the building and controls the Exhaust Damper and the Exhaust Fan. If the Building Pressure rises, the Exhaust Damper is proportionally controlled open and the Exhaust Fan is controlled ON. If the Building Pressure falls, the Exhaust Damper is proportionally controlled closed and the Exhaust Fan is controlled OFF. The position of the Exhaust Damper in which the Exhaust Fan is controlled ON and OFF as well as the Building Pressure setpoint is user selectable from the OptiLogic™ User Interface.

Powered Variable Volume Exhaust-VFD Controlled

This optional variable volume powered exhaust system consists of an Exhaust Fan driven by a Variable Frequency Drive (VFD), which is controlled by the OptiLogic™ controller. The OptiLogic™ controller monitors the pressure within the building. As the pressure rises, the VFD is controlled to increase Exhaust Fan speed. As the pressure falls, the VFD is controlled to decrease Exhaust Fan speed. The Building Pressure Setpoint is user selectable from the OptiLogic™ User Interface. On/Off control is maintained the same as Exhaust-Discharge Damper control stated above.

LOW AMBIENT OPERATION

The OptiLogic™ controller continuously monitors the outside air temperature to determine if mechanical cooling should be allowed. As a safety, if the Outside Air temperature falls to or below the Low Ambient Lockout temperature, mechanical cooling is prevented from operating. For units with economizers, the Low Ambient Lockout temperature is typically low enough that mechanical cooling will rarely be required. However, for some applications mechanical cooling is required when the Outside Air temperature is lower than the Low Ambient Lockout temperature.

For these applications, the unit must be equipped with optional Low Ambient controls. For optional Low Ambient operation, the OptiLogic™ controller monitors the refrigeration system discharge pressure and controls the speed of the condenser fans. If the discharge pressure falls, the speeds of the condenser fans are reduced to maintain acceptable condensing pressures in the refrigeration system. With the optional Low Ambient controls, mechanical cooling is allowed down to Outside Air temperatures of -17.7°C.

SMOKE PURGE SEQUENCES

General

As a convenience, for when buildings catch fire or the building is inundated with smoke or fumes from manufacturing processes, etc., the OptiLogic™ control system provides one of five ventilation override control sequences for building purge. The five selectable purge sequences are, Shutdown, Pressurization, Exhaust, Purge and Purge with duct pressure control. Note, when any of the purge sequences are activated, cooling and heating modes are disabled. A contact closure input is provided which indexes the OptiLogic™ controller into the selected purge sequence.

Shutdown

When this purge sequence is selected and activated, the supply and exhaust fans are controlled OFF and the Outside Air damper is overridden closed. This idle state is maintained until the purge input is deactivated and the unit returns to normal operation.

Pressurization

When this purge sequence is selected and activated, the exhaust fan is controlled OFF and the Supply Fan is controlled ON. The Outside Air damper is opened full and the Return Air Damper is closed full. If the unit is a VAV unit, the VAV boxes are also driven full open to prevent duct over-pressurization. This mode is maintained until the smoke purge input is deactivated and the unit returns to normal operation.

Exhaust

When this purge sequence is selected and activated, the Supply Fan is controlled OFF and the Exhaust Fan is controlled ON (Exhaust Damper driven full open and the outside air damper is closed). This mode is maintained until the smoke purge input is deactivated and the unit returns to normal operation.

Purge

When this purge sequence is selected and activated, the Supply Fan is controlled ON and the Exhaust Fan is controlled ON. The Outside Air damper is opened full and the Return Air damper is closed full. If the unit is a VAV unit, the VAV boxes are also driven full open to prevent duct over-pressurization. This mode is maintained until the smoke purge input is deactivated and the unit returns to normal operation.

Purge With Duct Pressure Control (VAV Only)

When this purge sequence is selected and activated, the Supply Fan is cycled ON and controlled to maintain the duct static pressure setpoint. The Exhaust Fan is also controlled ON (Exhaust Damper driven full open) and the Outside Air Damper is driven full open. This mode is maintained until the smoke purge input is deactivated and the unit returns to normal operation.

VAV SPECIFIC SEQUENCES

SUPPLY FAN OPERATION

For VAV units, the supply fan is controlled ON and OFF based on the occupancy state or the G input from a Thermostat (Unit must be configured for Thermostat operation to respond to the G input). When the unit goes into the Occupied mode of operation (or “G” is called) the Supply Fan will be controlled ON. The OptiLogic™ controller will monitor the static pressure within the supply duct system and control the speed of the supply fan to maintain a specified Duct Static Pressure setpoint. A Variable Frequency Drive (VFD) is used on all VAV units to vary the speed of the supply fan. Note, the use of a VFD in lieu of inlet guide vanes provides for higher energy efficiency for the unit by eliminating the losses (air pressure drop) typical of inlet guide vane systems.

COOLING OPERATION

Thermostat Control

When a VAV unit is configured for thermostat operation, the OptiLogic™ controller will command the Supply Fan to start when the unit goes into the Occupied mode or a thermostat “G” signal is received by the control. With no thermostat calls for cooling, the unit shall remain idle with the Supply Fan operating as required.

When a Cooling Stage 1 call (“Y1”) is received, and the unit is equipped with an economizer, the OptiLogic™ controller will check the Outside Air conditions to deter-

Controls (continued)

mine if conditions are suitable for economizing and modulate the outside air damper and/or stage up compressors as required to maintain the VAV High Supply Air Temperature Setpoint. This setpoint is user selectable at the OptiLogic™ User Interface. The OptiLogic™ controller will control to this setpoint as long as Cooling Stage 1 (“Y1”) remains active.

When a Cooling Stage 2 call (“Y2”) is received, and the unit is equipped with an economizer, the OptiLogic™ controller will check the Outside Air conditions to determine if conditions are suitable for economizing and modulate the outside air damper and/or stage up compressors as required to maintain the VAV Low Supply Air Temperature Setpoint. This setpoint is user selectable at the OptiLogic™ User Interface. The OptiLogic™ controller will control to this setpoint as long as Cooling Stage 2 (“Y2”) remains active.

The VAV High SAT Setpoint is always greater than the VAV Low SAT Setpoint and because of this essentially makes this control sequence a Supply Air Temperature Reset algorithm based on Zone Temperature or Outside Air.

Zone Sensor Control

When a VAV unit is configured for Zone Sensor operation, the OptiLogic™ controller will monitor a reference Zone Temperature and command the Supply Fan to start when the unit goes into the Occupied mode.

If the zone temperature is above the VAV Setpoint for SAT Reset, the OptiLogic™ controller will modulate the outside air damper (Economizer available and conditions suitable) and/or stage compressors up and down, as required, to maintain the VAV High Supply Air Temperature Setpoint.

If the zone temperature is below or falls below the VAV Setpoint for SAT Reset, the OptiLogic™ controller will modulate the Outside Air Damper (Economizer available and conditions suitable) and/or stage compressors up and down, as required, to maintain the VAV High Supply Air Temperature Setpoint.

As with thermostat operation, this sequence is also a Supply Air Temperature Reset algorithm based on Zone Temperature.

Stand-Alone Control

If the unit is not configured for Thermostat or Zone Sensor operation, the unit will operate in Stand-Alone Mode.

In Stand-Alone Mode, the OptiLogic™ Controller will monitor only the Occupied/Unoccupied state. When the unit is commanded into the Occupied Mode of operation, the OptiLogic™ Controller will start the Supply Fan. If the unit is equipped with an Economizer, the Controller will check to see if Outside Air conditions are suitable for Economizing. The controller will then use Outside Air (when available and suitable) and/or stage compressors up and down, as required, to maintain the VAV Low SAT Setpoint.

Supply Air Tempering

Supply Air Tempering is a continuation of the a VAV cooling operation when the outside air temperature is below the supply air temperature setpoint where heating is used to maintain economizer operation. This function will use small increments of heat to maintain the Supply Air Temperature when the economizer damper is at minimum position. If the unit is equipped with stepped heat (electric or gas), the heat will be duty cycled. A maximum of six cycles per hour is permitted for the heating stages.

HEATING OPERATION

VAV Occupied Heating

When VAV Occupied Heating is enabled, full heating will energize when either the thermostat W1 or W2 signal is received or the space temperature falls below the VAV Setpoint for SAT Reset by more than -16.6°C. If the return air temperature falls below the return air temperature setpoint for occupied heating, full heat capacity will be energized.

CV SPECIFIC SEQUENCES

COOLING OPERATION

Thermostat Control

If a 7-wire thermostat (2 Cool/2 Heat) controls the unit, all zone temperature setpoint control is maintained at the thermostat. With this operation, the unit remains idle until it receives a stage call from the thermostat. If “G” is called from the thermostat, the Supply Fan will start. Ventilation functions (if equipped) will be permitted to run with an occupied signal. Economizer functions will operate with a “G” call and a call for cooling.

Stage 1 (“Y1”) Call

If Y1 is called and the unit is equipped with an economizer, the control will check to see if the Outside Air is suitable for economizing. If conditions are suitable for economizing, the control will control the economizer and stage up compressors, as required, to maintain the economizer first-stage setpoint. If conditions are not suitable for economizing or not equipped with an economizer, the control will stage up 50% of the compressors. This shall be maintained until Stage 1 is deactivated or Stage 2 is called.

Stage 2 (“Y2”) Call

If Y2 is called and the unit is equipped with an economizer, the control will check to see if the Outside Air is suitable for economizing. If conditions are suitable for economizing, the control will control the economizer and stage up compressors, as required, to maintain the economizer second-stage setpoint. If conditions are not suitable for economizing or not equipped with an economizer, the control will stage up 100% of the compressors. This shall be maintained until Stage 2 is deactivated.

Zone Sensor Control

If a zone sensor controls the unit, the OptiLogic™ controller shall maintain the zone temperature setpoint. This setpoint is user selectable at the OptiLogic™ User Interface.

When a zone sensor is used for control, the OptiLogic™ unit controller will monitor the temperature within the space and control the unit accordingly. A closed-loop staging algorithm is used to stage compressors up and down as required to maintain the desired zone temperature setpoint. If the unit is equipped with an economizer, Outside Air conditions are continuously monitored by the control to determine if conditions are suitable for economizing. If conditions are suitable for economizing, the OptiLogic™ controller will modulate the Outside Air damper in addition to staging compressors up and down to maintain the zone temperature setpoint.

HEATING OPERATION**Thermostat Control**

If a 7-wire thermostat (2 Cool/2 Heat) controls the unit, all zone temperature setpoint control is maintained at the thermostat. With this operation, the unit remains idle until it receives a stage call from the thermostat. If “G” is called from the thermostat, the Supply Fan will start. Ventilation functions (if equipped) will be permitted to run with an occupied signal.

Stage 1 (“W1”) Call

If W1 is called and the unit is equipped with an economizer, the economizer will go to minimum position with an occupied signal or close with an unoccupied signal. and the control will stage up 50% of the heating steps. This shall remain active until Stage 1 call is deactivated or a Stage 2 call is activated.

Stage 2 (“W2”) Call

If W2 is called and the unit is equipped with an economizer, the economizer will go to minimum position with an occupied signal or close with an unoccupied signal, and the control will stage up 100% of the heating steps. This shall remain active until Stage 2 call is deactivated.

Zone Sensor Control

If a zone sensor controls the unit, the OptiLogic™ controller shall maintain all zone temperature setpoints. These setpoints are user selectable at the OptiLogic™ User Interface.

When a zone sensor is used for control, the OptiLogic™ unit controller will monitor the temperature within the space and control the unit accordingly. A closed-loop staging algorithm is used to stage heating steps up and down as required to maintain the desired zone temperature setpoint. If the unit is equipped with an economizer, Outside Air conditions are continuously monitored by the control to determine if conditions are suitable for economizing. If conditions are suitable for economizing, the OptiLogic™ controller will modulate the Outside Air damper in addition to staging heating steps up and down to maintain the zone temperature setpoint.

Power Wiring

SINGLE-POINT POWER SUPPLY WIRING

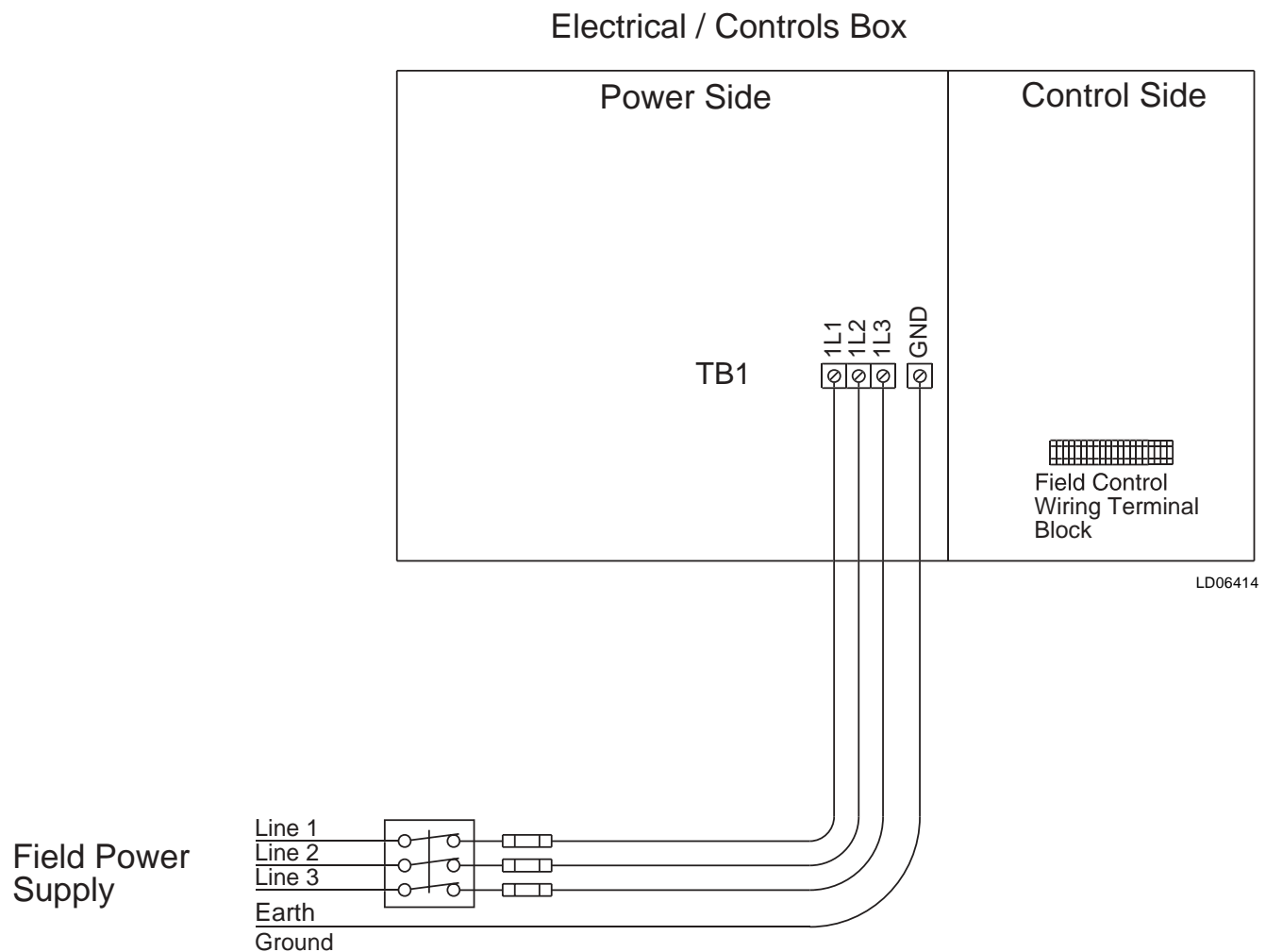

NOTES:

1. All field wiring must be provided through a field-supplied fused disconnect switch to the unit terminals (or optional molded disconnect switch).
2. All electrical wiring must be made in accordance with all N.E.C. and/or local code requirements.
3. Minimum Circuit Ampacity (MCA) is based on U.L. Standard 1995, Section 36.14 (N.E.C. Section 440.34).
4. Maximum Dual Element Fuse size is based on U.L. Standard 1995, Section 36.15 (N.E.C. Section 440.22)
5. Use copper conductors only.
6. On units with an optional disconnect switch, the supplied disconnect switch is a "Disconnecting Means" as defined in the N.E.C. Section 100, and is intended for isolating the unit from the available power supply to perform maintenance and troubleshooting. This disconnect switch is not intended to be a Load Break Device.

FIG. 1 – SINGLE-POINT POWER SUPPLY WIRING

SINGLE-POINT POWER SUPPLY WIRING WITH NON-FUSED DISCONNECT

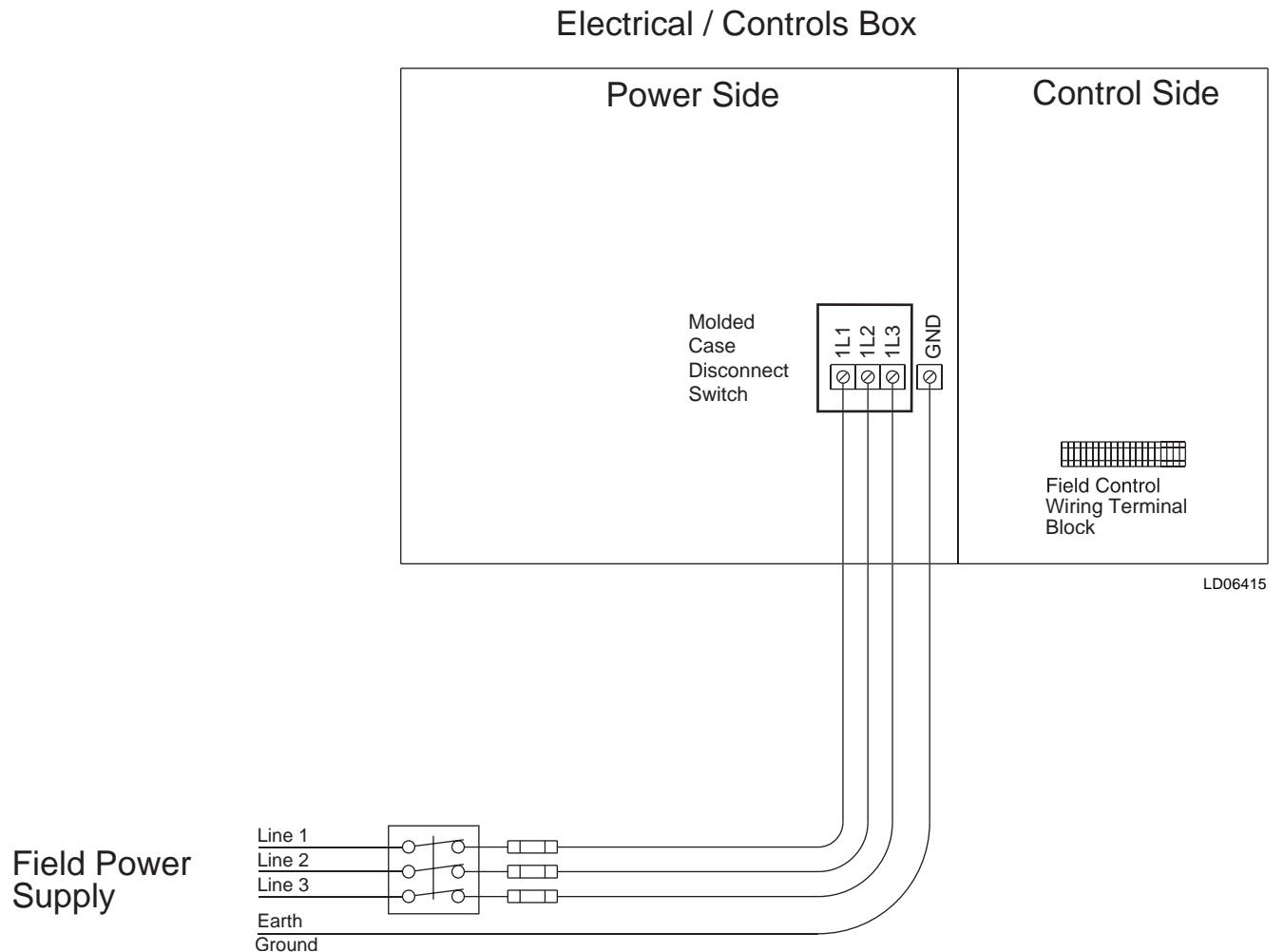

NOTES:

1. All field wiring must be provided through a field-supplied fused disconnect switch to the unit terminals (or optional molded disconnect switch).
2. All electrical wiring must be made in accordance with all N.E.C. and/or local code requirements.
3. Minimum Circuit Ampacity (MCA) is based on U.L. Standard 1995, Section 36.14 (N.E.C. Section 440.34).
4. Maximum Dual Element Fuse size is based on U.L. Standard 1995, Section 36.15 (N.E.C. Section 440.22)
5. Use copper conductors only.
6. On units with an optional disconnect switch, the supplied disconnect switch is a "Disconnecting Means" as defined in the N.E.C. Section 100, and is intended for isolating the unit from the available power supply to perform maintenance and troubleshooting. This disconnect switch is not intended to be a Load Break Device.

FIG. 2 – SINGLE-POINT POWER SUPPLY WIRING WITH NON-FUSED DISCONNECT

Power Wiring (continued)

DUAL-POINT POWER SUPPLY WIRING

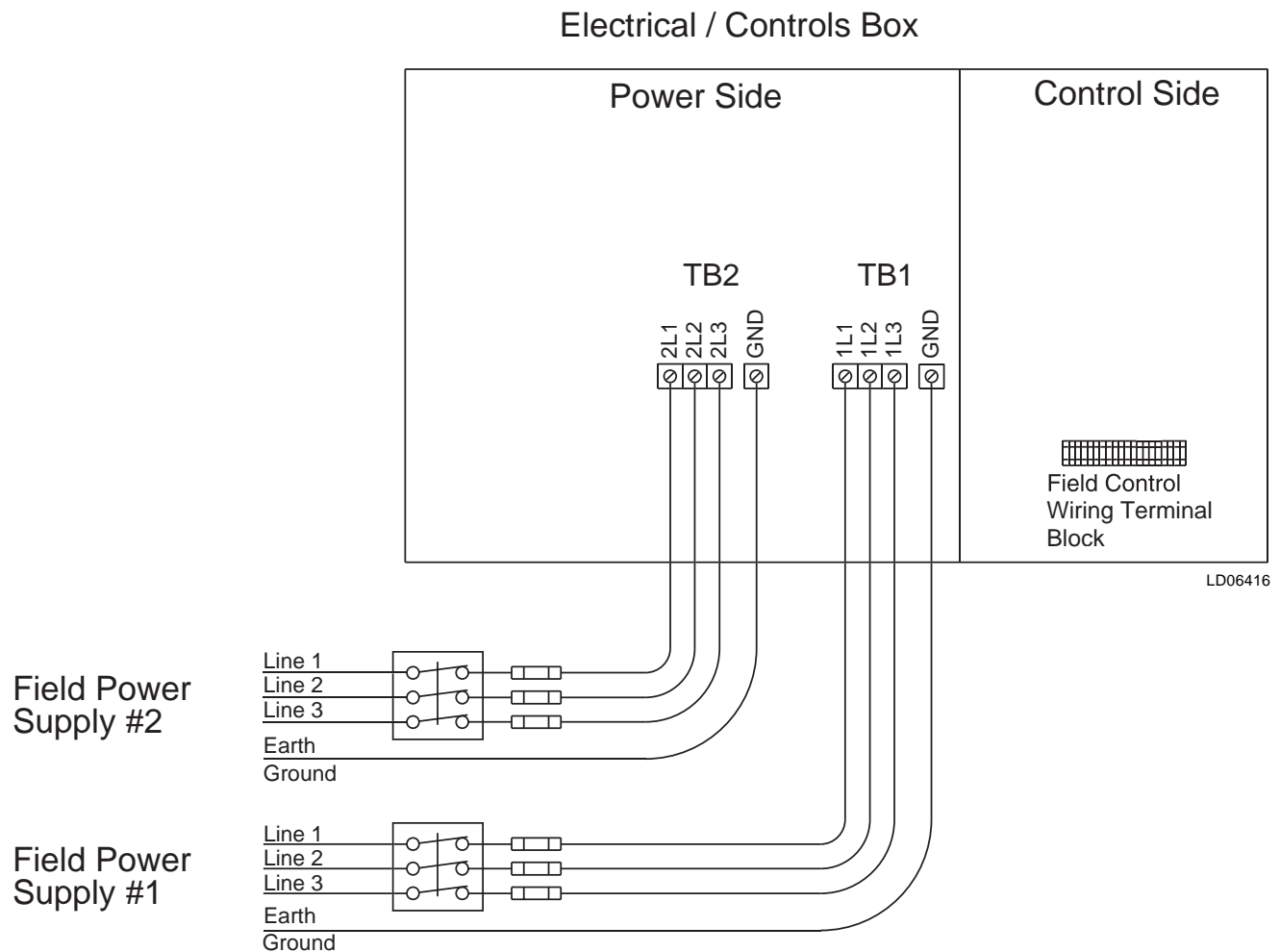

NOTES:

1. All field wiring must be provided through a field-supplied fused disconnect switch to the unit terminals (or optional molded disconnect switch).
2. All electrical wiring must be made in accordance with all N.E.C. and/or local code requirements.
3. Minimum Circuit Ampacity (MCA) is based on U.L. Standard 1995, Section 36.14 (N.E.C. Section 440.34).
4. Maximum Dual Element Fuse size is based on U.L. Standard 1995, Section 36.15 (N.E.C. Section 440.22)
5. Use copper conductors only.
6. On units with an optional disconnect switch, the supplied disconnect switch is a "Disconnecting Means" as defined in the N.E.C. Section 100, and is intended for isolating the unit from the available power supply to perform maintenance and troubleshooting. This disconnect switch is not intended to be a Load Break Device.

FIG. 3 – DUAL-POINT POWER SUPPLY WIRING

Field Control Wiring

Wiring Notes:

1. Wiring shown indicates typical wiring.
2. All wiring is Class 2, low voltage.
3. Maximum power available from the 24 VAC terminal is 40VA.
4. Use shielded wire where shown.

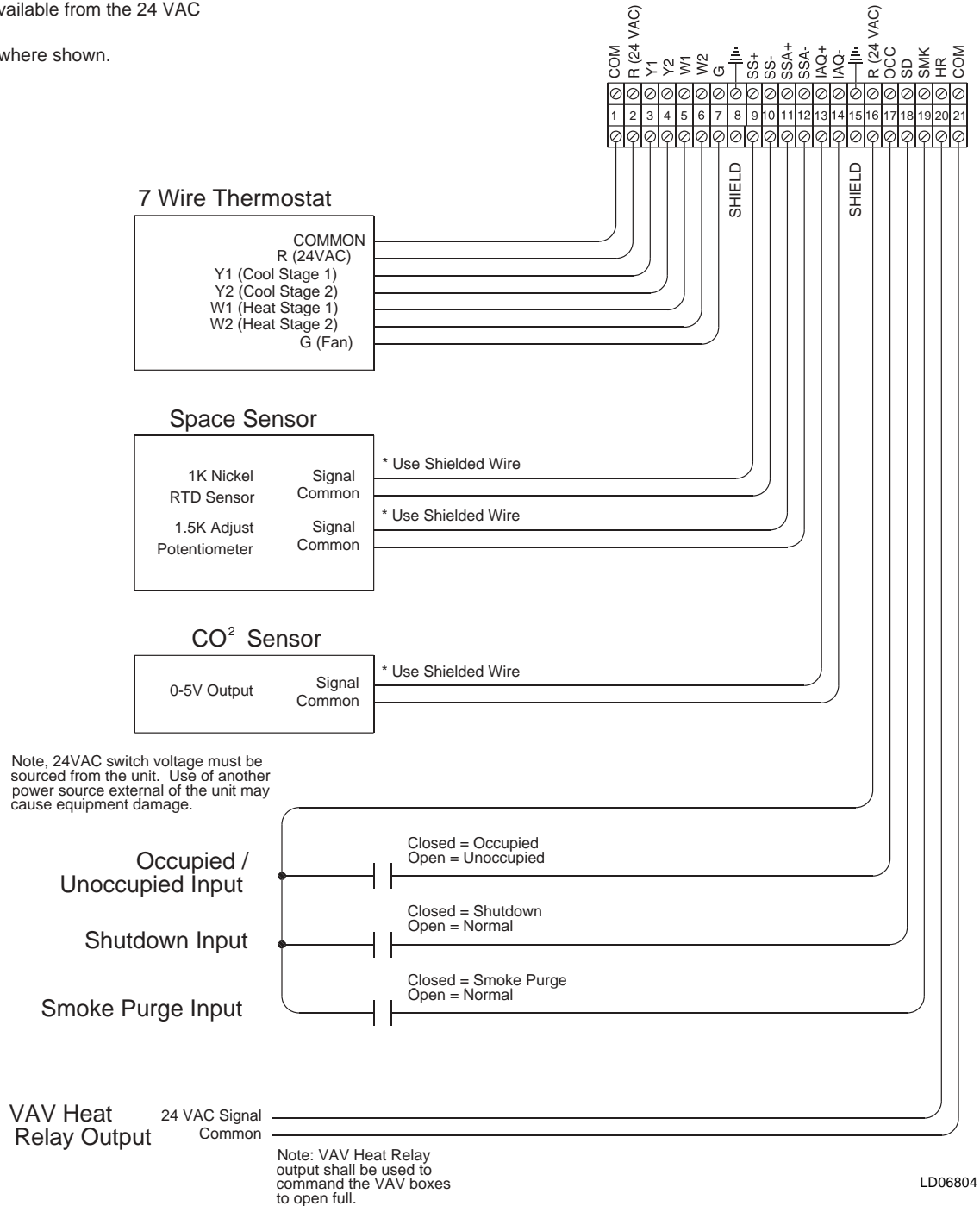

LD06804

FIG. 4 – FIELD CONTROL WIRING

General Arrangement Drawing – 50-65 Ton Models

BOTTOM SUPPLY / BOTTOM RETURN

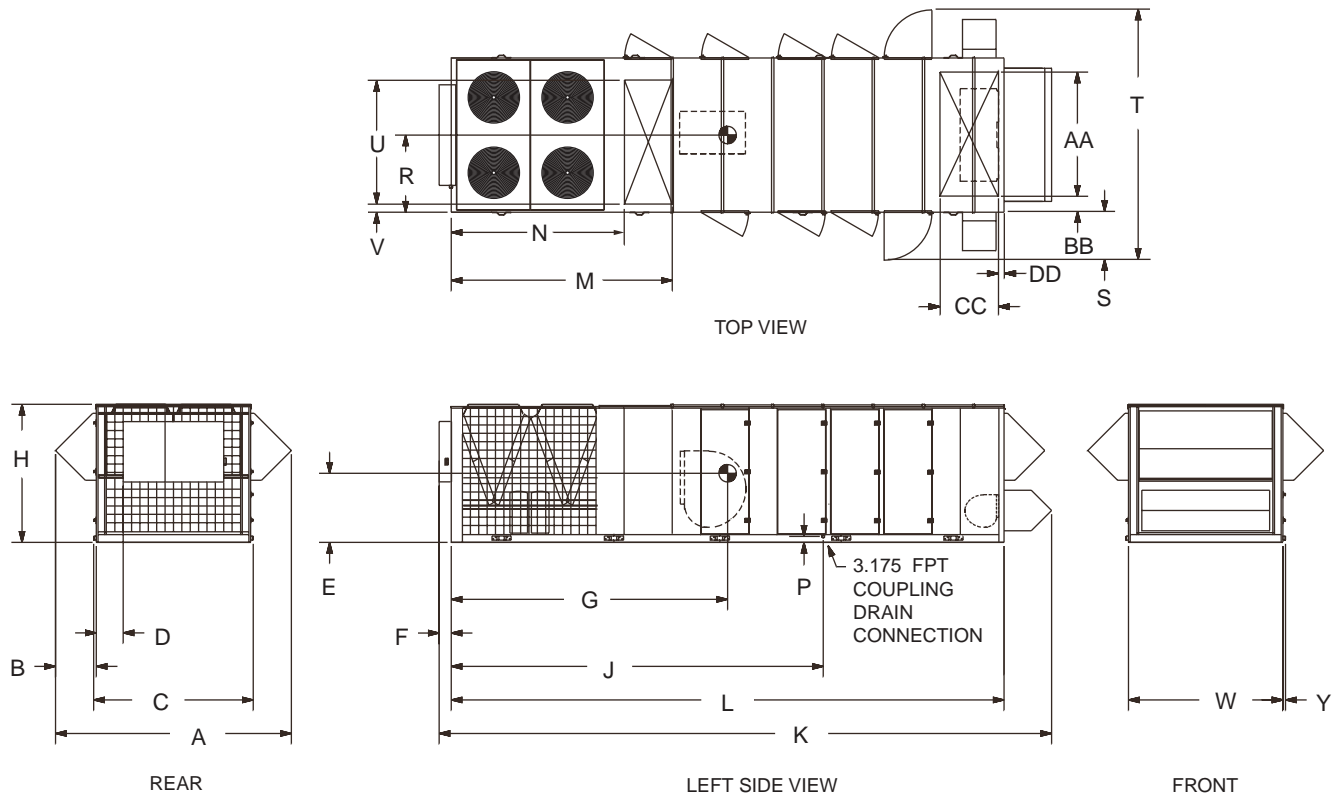

LD07880

TABLE 29 – BOTTOM SUPPLY / BOTTOM RETURN (ALL DIMENSIONS ARE IN CM)

MODEL	A	B	C	D	E	F	G	H	J	K	L	M	N
50-65	350.04	58.1	241.61	49.69	91.44	24.61	485.14	209.87	600.7	973.30	873.76	369.89	270.83

MODEL	P	R	S	T	U	V	W	Y	AA	BB	CC	DD
50-65	6.03	124.46	72.39	378.46	179.38	11.75	233.68	3.97	210.18	11.75	90.33	11.75

NOTES:

1. Standard configuration.
2. Center of gravity information is based on a base cooling only unit equipped with power exhaust and economizer options.

FIG. 5 – GENERAL ARRANGEMENT DRAWING – 50-65 TON MODEL

SIDE SUPPLY / FRONT RETURN

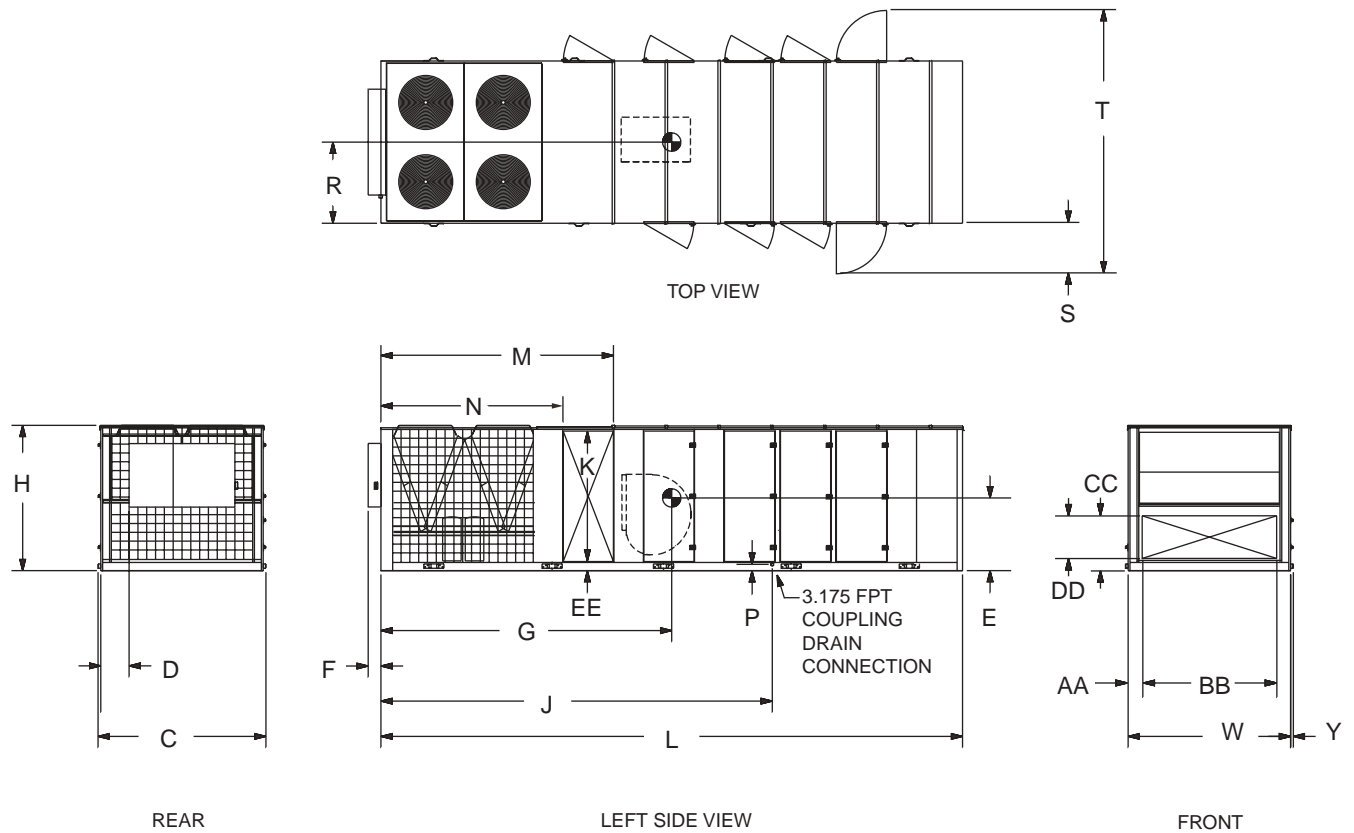

LD07881

TABLE 30 – SIDE SUPPLY / FRONT RETURN (ALL DIMENSIONS ARE IN CM)

MODEL	C	D	E	F	G	H	J	K	L	M	N
50-65	241.61	49.69	96.52	24.61	543.56	209.87	600.7	183.51	873.76	369.09	300.51

MODEL	P	R	S	T	W	Y	AA	BB	CC	DD	EE
50-65	6.03	124.46	72.39	378.46	233.68	3.97	16.35	201.30	90.49	74.61	15.87

NOTES:

1. Left and right hand side openings are the same size.
2. Right supply available with cooling only units.
3. Left supply available with cooling only and gas heat units.
4. Bottom supply available on all configurations.
5. Rear return not available with exhaust/relief options.
6. Center of gravity information is based on a base cooling only unit.

FIG. 6 – GENERAL ARRANGEMENT DRAWING – 70-95 TON MODEL

General Arrangement Drawing – 70-95 Ton Models

BOTTOM SUPPLY / BOTTOM RETURN

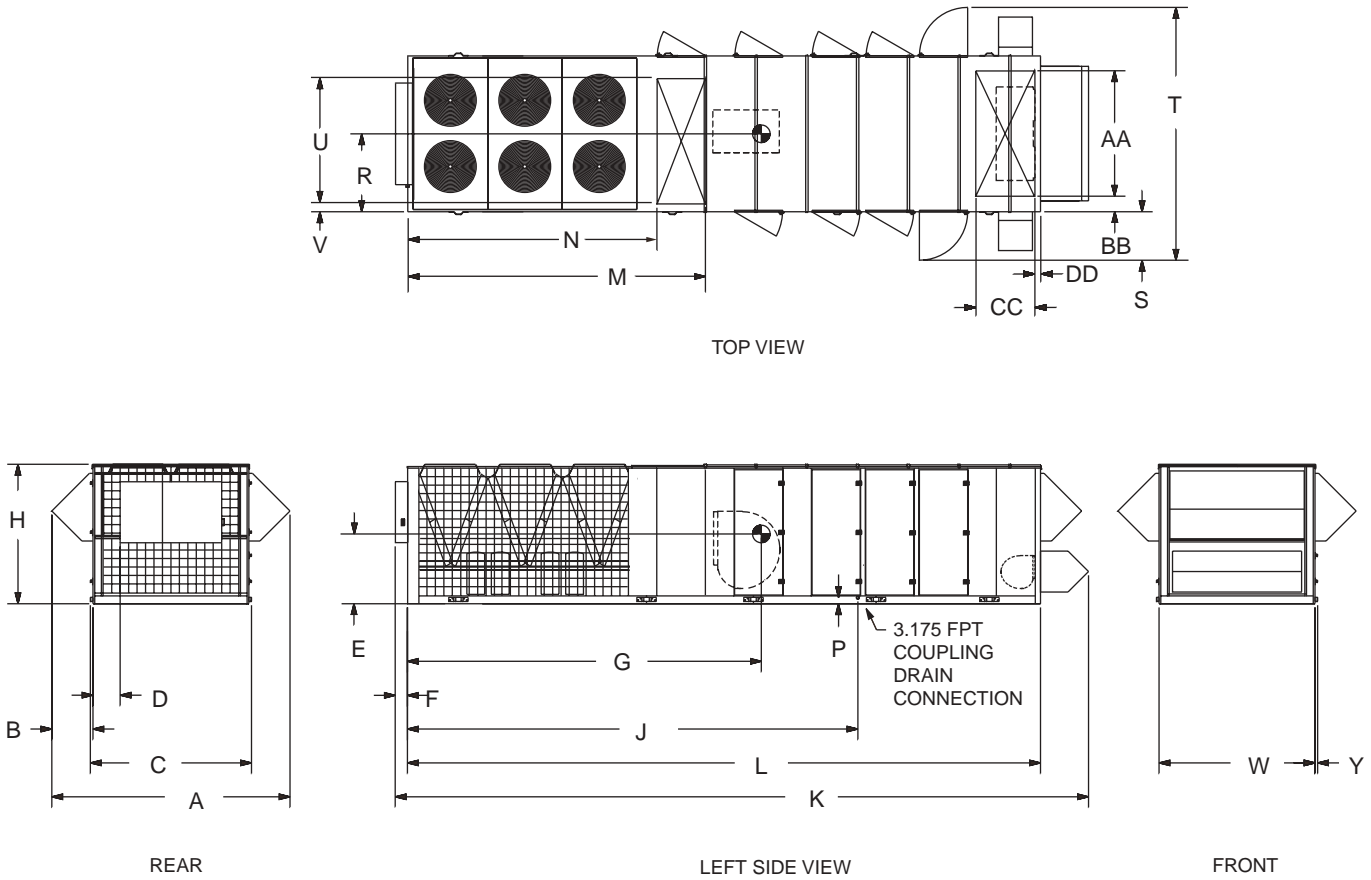

LD07882

TABLE 31 – BOTTOM SUPPLY / BOTTOM RETURN (ALL DIMENSIONS ARE IN CM)

MODEL	A	B	C	D	E	F	G	H	J	K	L	M	N
70-85	350.04	58.1	241.61	49.69	96.52	24.61	574.04	235.27	814.07	1260.48	1153.16	519.43	410.21
90-95	350.04	58.1	241.61	49.69	96.52	24.61	614.68	235.27	826.77	1351.28	1239.52	532.13	410.21

MODEL	P	R	S	T	U	V	W	Y	AA	BB	CC	DD
70-85	6.033	121.92	87.63	408.94	179.39	11.75	233.68	3.97	210.19	11.75	121.92	11.75
90-95	6.033	121.92	72.39	378.46	179.39	11.75	233.68	3.97	210.19	11.75	137.16	11.75

NOTES:

1. Standard configuration.
2. Center of gravity information is based on a base cooling only unit equipped with power exhaust and economizer options.

FIG. 7 – GENERAL ARRANGEMENT DRAWING – 70-95 TON MODEL

SIDE SUPPLY / REAR RETURN

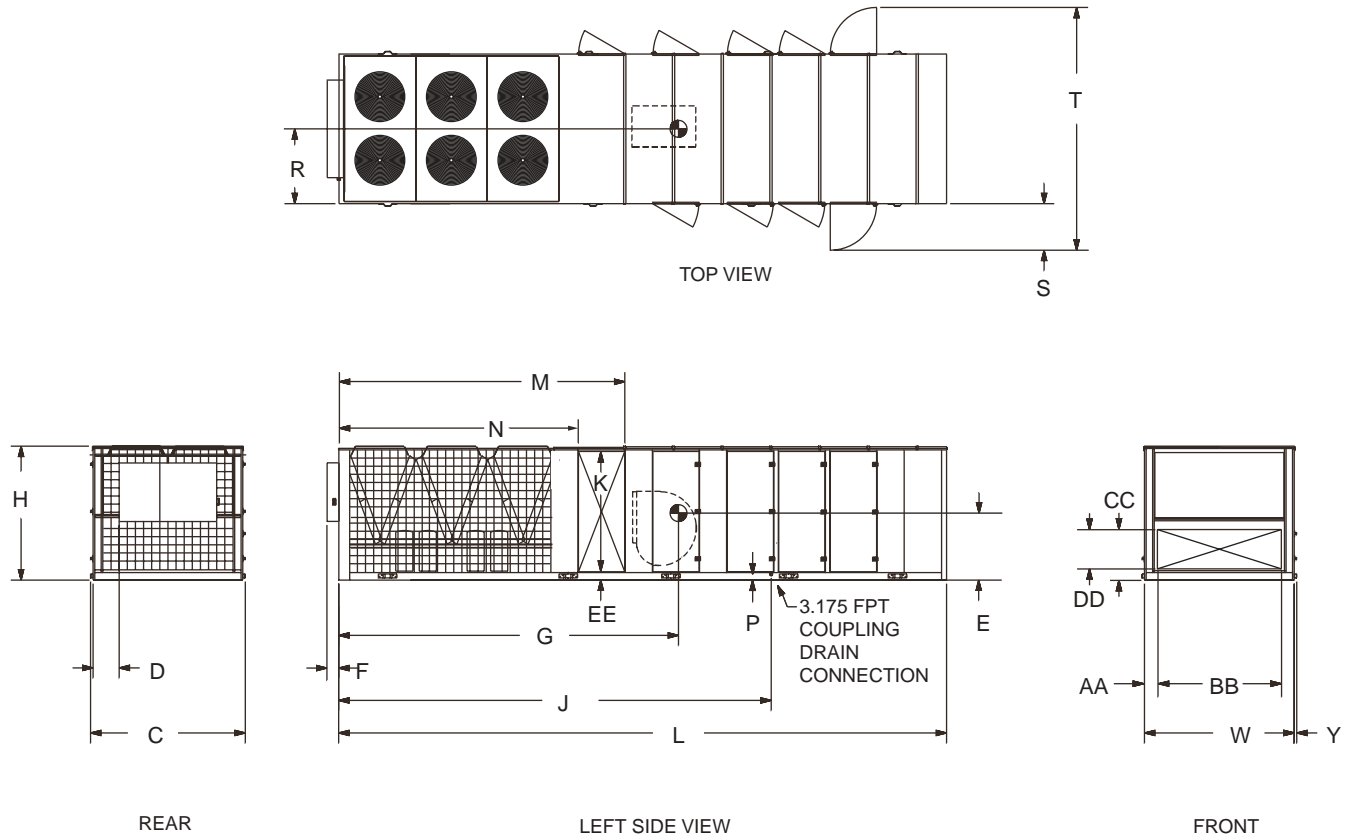

LD07883

TABLE 32 – SIDE SUPPLY / FRONT RETURN (ALL DIMENSIONS ARE IN CM)

MODEL	C	D	E	F	G	H	J	K	L	M	N	P
70-85	241.61	49.69	99.06	24.61	640.08	235.27	814.07	209.07	1153.16	562.29	414.97	6.03
90-95	241.61	49.69	99.06	24.61	688.34	235.27	826.77	209.07	1239.52	569.91	414.97	6.03

MODEL	R	S	T	W	Y	AA	BB	CC	DD	EE
70-85	119.38	87.63	408.94	233.68	3.97	16.35	201.3	93.03	77.15	15.875
90-95	119.38	72.39	378.46	233.68	3.97	16.35	201.3	113.35	97.47	15.875

NOTES:

1. Left and right hand side openings are the same size.
2. Right supply available with cooling only units.
3. Left supply available with cooling only and gas heat unit.
4. Bottom supply available on all configurations.
5. Rear return not available with exhaust/relief options.
6. Rear return not available with exhaust/relief options.
7. Center of gravity information is based on a base cooling only unit.

FIG. 8 – GENERAL ARRANGEMENT DRAWING – 70-95 TON MODEL

General Arrangement Drawing – 70-95 Ton Models (ONLY)

OPTIONAL SIDE RETURN

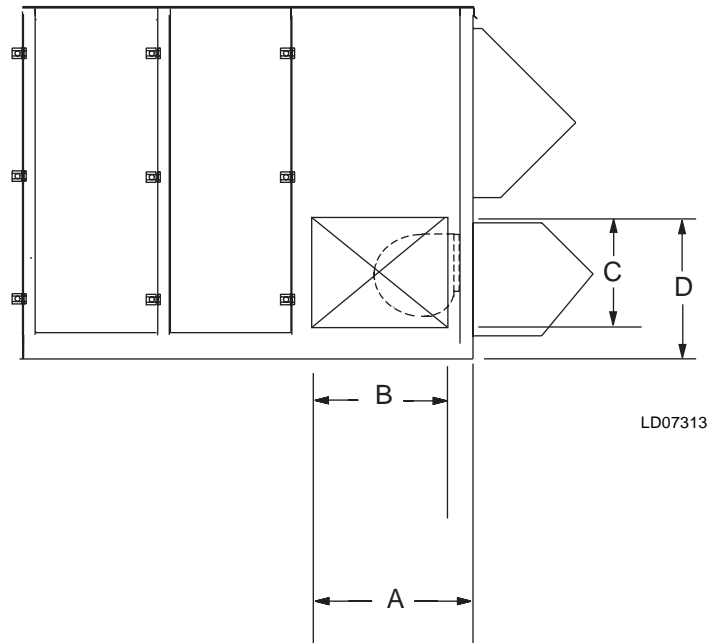

NOTE:

1. Left side shown, RH side available (mirror image).

TABLE 33 – OPTIONAL SIDE RETURN (CM)

MODEL	A	B	C	D
70-85	157.80	147.32	101.6	128.91
90-95	174.62	164.14	105.73	131.13

FIG. 9 – GENERAL ARRANGEMENT DRAWING – 70-95 TON MODEL (ONLY)

Curb Layout Drawing

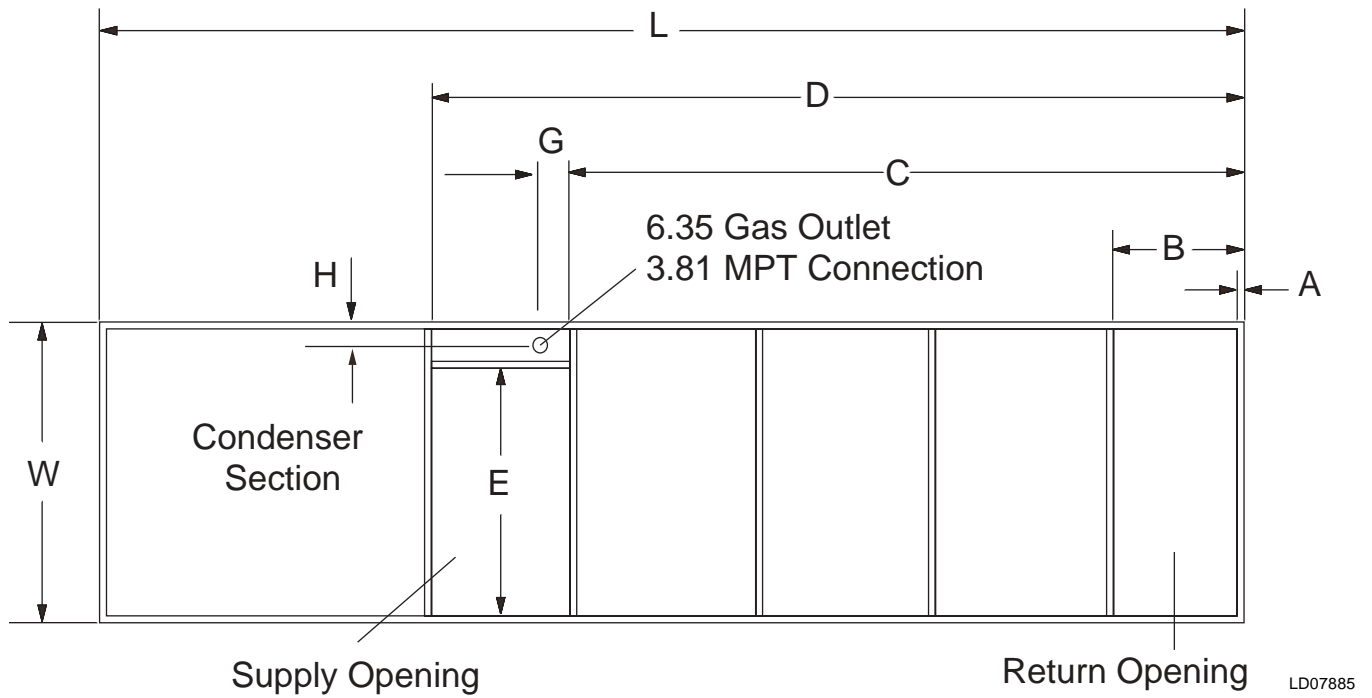

UNIT BASERAIL PROFILE

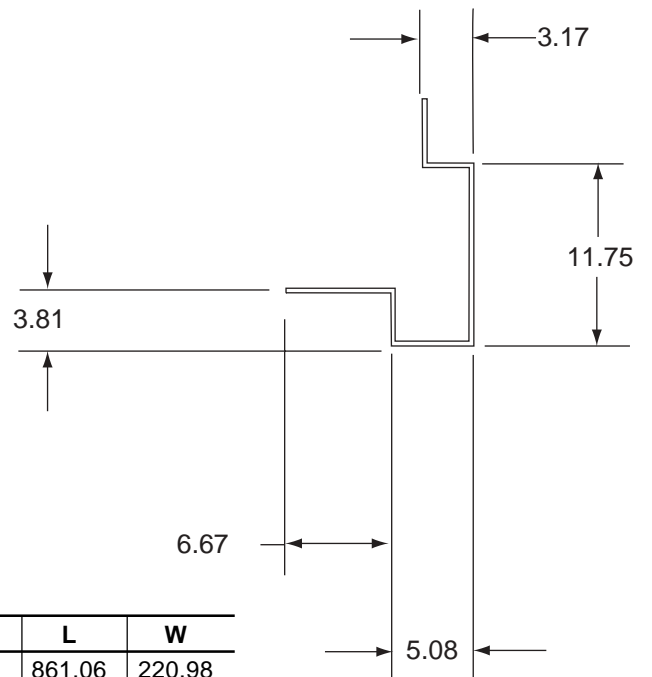
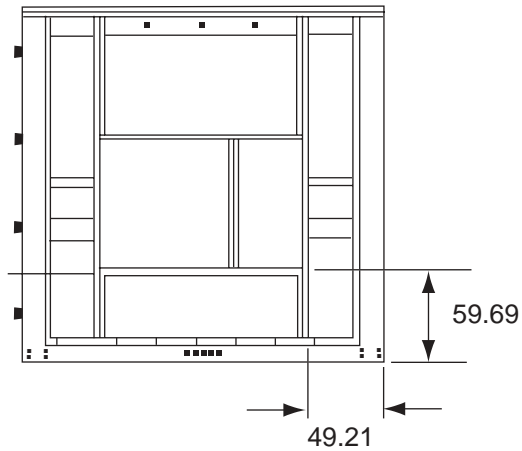

TABLE 34 – CURB LAYOUT DIMENSIONS (CM)

MODEL	A	B	C	D	E	G	H	L	W
50-65	5.08	95.89	495.3	596.9	181.77	40.64	26.03	861.06	220.98
70-85	5.08	127	627.38	736.6	181.77	45.72	26.03	1140.46	220.98
90-95	5.08	142.88	701.04	822.96	181.77	60.96	26.03	1226.82	220.98

FIG. 10 – CURB LAYOUT DRAWING

Power/Control Entry Drawing



POWER SUPPLY KNOCKOUTS

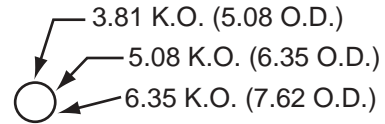

END VIEW

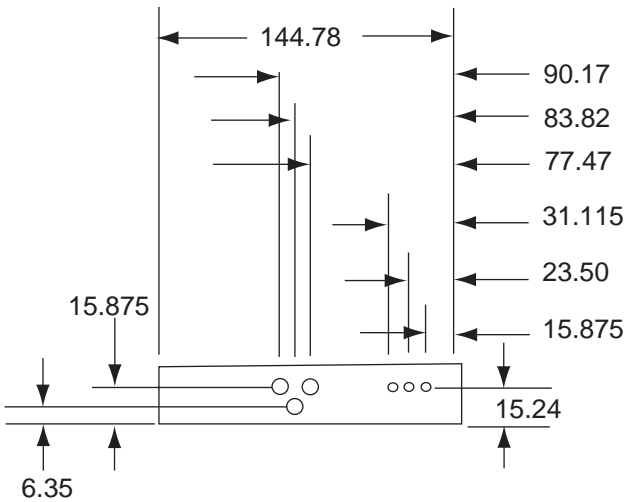

PANEL A

1.905 K.O. (CONTROL WIRING)

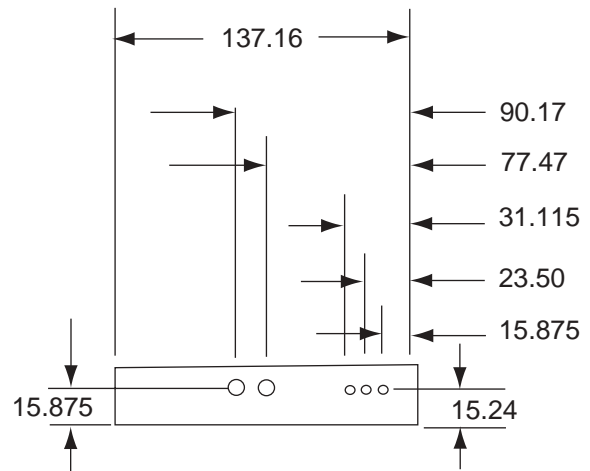

PANEL B

1.905 K.O. (CONTROL WIRING)

LD07886

BOTTOM VIEW

TABLE 35 – POWER/CONTROL ENTRY DIMENSIONS ARE IN CM

MODEL	208V	230V	460V	575V
50	A	A	B	B
55	A	A	B	B
60	A	A	B	B
65	A	A	B	B
70	A	A	B	B
75	A	A	B	B
80	A	A	B	B
85	A	A	B	B
90	A	A	A	A
95	A	A	A	A

FIG. 11 – POWER/CONTROL ENTRY DRAWING – 50 - 95 TON MODELS

Guide Specifications

GENERAL

Units shall be designed for outdoor rooftop installation on a roof curb (optional). Units shall be capable of providing mechanical cooling down to 7.2°C (-17.7°C with a low ambient kit). Unit shall be capable of starting and running at 48.8°C. Unit electric and gas connections shall be either through the curb or the side of the unit.

QUALITY ASSURANCE

Units shall be rated according to ARI 360 and conform to ASHRAE 90.1 energy efficiency requirements. Units shall be shipped in a single package, fully charged with HFC-407C (HCFC-22 optional) refrigerant. The manufacturing facility shall be registered under ISO 9001 Quality Standards for Manufacturing. All units shall be completely factory wired and assembled, and undergo a complete and automated factory run test. The factory run test shall confirm proper operation of all functional components on the unit, configure the unit controller per the project and test the unit controller. Units shall be E.T.L. listed and be tested according to U.L. 1995.

Warranty

Manufacturer shall Warrant all equipment and material of its manufacture against defects in workmanship and material for a period of one year from date of initial start-up or eighteen (18) months from date of shipment, whichever occurs first.

SHIPPING PREPARATION AND UNIT CLEANLINESS

All units shall be shipped from the factory shrink-wrap in plastic to maintain a clean unit interior for maximum indoor air quality and to protect the exterior finish of the unit during transit. Tags and decals to aid in the service or indicate caution areas shall be provided. Installation, operation and maintenance manuals shall be supplied with each unit.

CONSTRUCTION

Base

The base rail shall be constructed of 12-gauge galvanized steel, extending the full perimeter of the unit. All components shall be supported from the base, and the base shall include integral lifting lugs. The unit base rail shall overhang the roof curb for water runoff and shall have a fabricated recess with a continuous flat surface to seat on the roof curb gasket, providing a positive, weather tight seal between the unit and the curb.

Casing

The unit cabinet shall be one-inch double-wall construction of all panels, doors, floor, roof and walls to provide both maximum resistance to bacterial growth in the air stream and superior structural integrity. All sheet metal shall be G90 mill galvanized sheet metal, formed and reinforced to provide a rigid assembly. Cabinet shall be coated with baked on powder paint which, when subject to ASTM B117, 500 hour, 5% salt spray test. The unit shall be insulated with 1-1/2 pound fiberglass insulation between the two sheet metal skins. Insulation shall meet NFPA-90A regulations for smoke and flame spread ratings. Single-wall units, or foil-faced insulation in the air stream shall be not acceptable.

The cabinet corner post and the intermediate side supports shall be a minimum of 16-gauge steel. All access doors shall be a minimum of 18-gauge on the exterior surfaces, and 20-gauge on the interior. Interior floor panels shall be 18-gauge. All serviceable sections shall have hinged access doors with latches on both sides of the unit. Each door shall seal against gaskets to prevent air and water leakage.

The roof shall be double wall, with 18-gauge on the external surface and 24-gauge on the interior. The roof shall be formed with a 45 degree "drip lip" overhanging the side walls to prevent precipitation drainage from streaming down the side of the unit. Roof sections shall be connected together via integral channels fastened with screws and sealed with gasketing. Each fastened seam shall be further protected by a sheet metal channel covering the full length of the gasket surface, making a completely water tight seal.

SUPPLY AIR FAN

Fan shall be centrifugal type, statically and dynamically balanced in the factory. Fan wheels shall be designed for continuous operation at the maximum rate of fan speed and motor HP. Fans shall be double-width, double-inlet with forward curved blades.

The fan and motor assembly shall be mounted on a common base to allow consistent belt tension with no relative motion between the fan and motor shafts. The entire assembly shall be isolated from the unit base with 1" deflection springs. The fan discharge shall be connected to the cabinet through a reinforced neoprene flexible connection to eliminate vibration transmission from the fan to the unit casing.

Bearings shall be self-aligning pillow-block re-greasable ball bearings with an average life expectancy L50 of 200,000 hours. Grease fittings shall be accessible through access doors.

Guide Specifications (continued)

Fan motors shall be NEMA designed, Standard efficiency ball bearing type with electrical characteristics and horsepower as specified. Motors shall be 1750 RPM, open drip proof type. The motor shall be located within the unit on an adjustable, heavy steel base.

All fan motor drives shall be selected for a minimum service factor of 1.2 and have fixed pitched sheaves.

AIR FILTERING SYSTEM

All filter holding frames shall be of heavy-duty construction designed for industrial applications. All filters shall be accessible from either side via access doors on both sides of the filter section.

All filter media shall be Class II listed under U.L. Standard 900. Filter efficiencies shall be rated in accordance with ASHRAE Standard 52.

Two-inch throwaway filters in an angled filter rack shall be standard. On units with rigid filters, two-inch prefilters shall be installed upstream of the rigid filters.

AIR INLET SYSTEM

A factory installed outside air rain hood permanently attached to the cabinet to prevent windblown precipitation from entering the unit shall cover inlet openings. The rain hoods on the sides of the unit shall be rotated into the cabinet and secured for shipment so that upon installation they need only be rotated upwards and screwed into place. The outside air hood shall contain a removable and cleanable filter.

All damper assemblies shall be of low leak design. Damper blades shall be fabricated from a minimum of 16-gauge galvanized steel.

REFRIGERATION SYSTEM

Units shall have four compressors (six for YPAL070 - 095) for maximum load-matching capability. Each refrigerant circuit shall be controlled by two thermal expansion valves for maximum control at low load conditions.

Evaporator Coils

Evaporator coils shall be direct expansion. Coil tubes shall be 1/2" OD copper, with internally enhanced tubes. Fins shall be enhanced aluminum mechanically expanded to bond with the copper tubes. Coil casing shall be fabricated from heavy gauge galvanized steel.

A stainless steel double-sloped drain pan shall be provided under the entire width of the evaporator coil, including all return bends. The main drain pan shall be sloped a total of 1/4" per foot towards the drainage point according to ASHRAE 62 guidelines. Main drain pan shall be accessible and cleanable in the field. The condensate drain opening shall be flush with the bottom of the drain pan to allow complete drainage.

Compressors

Compressors shall be hermetic, scroll-type, including tip seals to provide efficient axial sealing while preventing scroll tip to base contact, controlled orbit design for radial sealing to incorporate minimum flank-to-flank contact for long service life, refrigerant cooled motors, large suction side free volume and oil sump to provide liquid handling capability, annular discharge check valve and reverse vent assembly to provide low pressure drop, silent shutdown and reverse rotation protection, initial oil charge, oil level sight glass, vibration isolator mounts for compressors, and brazed-type connections for fully hermetic refrigerant circuits.

Condenser Coils

Condenser coils shall have 3/8" seamless copper tubes, arranged in staggered rows, mechanically expanded into aluminum fins. Coils shall be protected from hail damage with a "V" configuration, with individual flat coils rotated from the vertical plane for each condensing circuit.

Condenser Fans and Motors

Condenser fans shall be direct drive, propeller type, discharging vertically. Condenser fan motors shall be 3-phase, totally enclosed air over (TEAO). Thermal overload protection shall be provided for each condenser fan motor.

Refrigerant Piping

All interconnecting piping between refrigeration components shall be copper tubing with brazed joints.

Each refrigerant circuit shall be equipped with liquid line filter drier, and moisture indicating sight glass. Each circuit shall also have both high and low pressure switches and include access fittings for replacement of the pressure switches without removing charge.

Polyurethane sleeves shall protect all small diameter distributor tubing to the evaporator coil to prevent the tubes from copper-to-copper contact during shipment or operation.

POWER SUPPLY

Unit power supply shall be 460V 3-phase 60 Hz (208, 230 and 575V optional) single-point power connections with terminal block connections.

GAS-FIRED HEATING SECTION

One or two (or three for the YPAL070-095) gas-fired heating modules shall be installed to provide the heating requirements per the schedule shown on the plans.

The heat exchanger shall be of tubular design. Tubes shall be 2-1/4" OD and constructed of minimum 20-gauge, G160 aluminized steel (1.6 mil aluminum silicocone alloy) for corrosion resistance.

Each gas-fired heat module shall have an induced draft combustion fan with reliable spark ignition and redundant gas valves with pressure regulator.

An induced draft fan shall be provided to maintain a positive flow of air through each tube, to expel the flue gas and to maintain a negative pressure within the heat exchanger relative to the conditioned space. Induced draft fans shall be direct-drive.

Dual (2) high limit controllers per heating module, with automatic reset to prevent the heat exchanger from operating at an excessive temperature will be installed. A safety pressure switch in the induced draft fan motor circuit must be provided to prevent ignition until sufficient air flow is established through the heat exchanger. Airflow safety shall be provided by rollout switch protection and shall discontinue furnace operation if the flue becomes restricted.

Units shall ship with an external flue to be shipped in the unit and mounted on the job site. The flue shall discharge products of combustion above the unit, preventing recycling of corrosive combustion gases back through the heat exchanger. Gas heating sections shall be U.L./CSA certified to both US and Canadian safety standards.

ELECTRIC HEAT SECTION

An electric slip-in heater shall be installed within the rooftop unit to provide the heating requirements per the schedule shown on the plans. The electric heater shall be wired in such a manner as to provide multiple steps of capacity.

The heater shall be an industrial grade design using an open coil(s) made of the highest grade resistance wire

containing 80% nickel and 20% chromium. The resistance coil(s) shall be adequately supported in the air stream using ceramic bushings in the supporting framework. Terminals of the coil(s) shall be stainless steel with high temperature ceramic bushings.

The primary high temperature protection shall be an automatic reset type thermal cut out. Secondary protection shall be an automatic reset type thermal cut out. Secondary protection shall be a replaceable thermal link.

The operation of the electric heater shall be an integral part of the roof top control system. Power connection to the strip heater shall be through the single power point connection for the entire unit. Electric heat shall be E.T.L. certified.

CONTROLS

A factory-mounted unit controller with a 4x20 character alphanumeric display and one-touch keypad shall be included as standard. The controller and keypad shall be housed inside the low-voltage compartment of the control/power panel. On units with supply or exhaust VFDs, the VFD keypads shall be located inside the same panel as the unit controller and interface keypad. Control operating data, setpoints, unit setup, configuration, service and history shall all be accessible via a single key. A system alarm LED shall indicate failures to the operator with more detail provide in the menu screens. The user interface shall function with a simple menu-driven display for easy access to unit data with integral time clock for weekly and holiday scheduling. The unit keypad shall include password protection to prevent unauthorized access and tampering with unit setpoints and configuration.

A single terminal strip shall be provided for all thermostat and customer hard-wire connections.

Unit controls shall be completely factory packaged and compatible with a room thermostat. Constant volume units shall operate with a two (2) cool/two (2) heat thermostat. Staging decisions shall be based upon the deviation of space temperature from set point and the rate of change of the space temperature.

VAV units shall operate with a sensor in the supply air stream for cooling operation. Staging decisions shall be based upon the deviation of supply air temperature from set point and the rate of change of the supply air temperature.

Controllers shall have the following safeties (both VAV and CV):

Guide Specifications (continued)

- High and low pressure cutouts (one each refrigerant circuit)
- Minimum on time for compressors
- Delay between compressor stages
- Anti-short cycle delays (minimum off time) for compressors and supply fan
- Cooling lockout at 7.2°C; -17.7°C if equipped for low ambient operation
- Air flow proving switch which proves that the fan is operational

POWER OPTIONS

Single-Point Supply with Terminal Block – includes enclosure, terminal-block, and interconnecting wiring to the compressors. Separate external protection must be supplied, by others, in the incoming compressor power wiring. (Do not include this option if either the Single-Point Non-Fused Disconnect Switch or Single-Point Circuit Breaker options have been included.)

Single-Point Supply with Non-fused Disconnect Switch – A unit-mounted disconnect switch with external, lockable handle (in compliance with Article 440-14 of N.E.C.), can be supplied to isolate the unit power voltage for servicing. Separate external fusing must be supplied, by others in the power wiring, which must comply with the National Electric Code and/or local codes. (This option includes the Single-Point Power connection.)

Dual-Point Supply with Terminal Block – includes enclosure, one terminal-block with interconnecting wiring to the supply and exhaust fans and control transformer and a second terminal block with interconnecting wiring to the compressors and condenser. Separate external protection must be supplied, by others, in the incoming compressor power wiring.

Convenience Outlet – an optional 115V convenience outlet can be provided to power hand tools for servicing the rooftop unit.

CONTROL OPTIONS

Note: On standard units, mechanical cooling may operate down to 7.2°C.

Low Ambient on System One – This option includes low ambient control of the first refrigerant system down to 0°F through the use of discharge pressure transducer and a variable speed drive that will vary the speed of the condenser fan to control condensing pressure. Mechanical cooling with system two (and three for YPAL070-095) is locked out below 7.2°C.

Low Ambient on Systems One and Two – This option includes low ambient control of the first and second refrigerant system down to -17.7°C through the use of discharge pressure transducers and variable speed drives that will vary the speed of the condenser fans to control condensing pressure. This option applies to YPAL050-065 models. On YPAL070-095 models, mechanical cooling with system three is locked out below 7.2°C.

Low Ambient on Systems One, Two and Three – This option includes low ambient control of the first, second, and third refrigerant system down to -17.7°C through the use of discharge pressure transducers and variable speed drives that will vary the speed of the condenser fans to control condensing pressure. This option not available on models YPAL050-065.

Low Ambient on System One + Transducers on System 2 (and 3 for YPAL070-095) – on standard units, mechanical cooling may operate down to 7.2°C. This option includes low ambient control of the first refrigerant system down to -17.7°C through the use of suction and discharge pressure transducers on system one. Suction and discharge pressure transducers are included on remaining system(s) for readout only. Mechanical cooling with remaining system(s) is locked out below 7.2°C.

Pressure Transducer with Readout Capability – suction and discharge pressure transducers are configured for pressure readout of all systems. This option is available only on units without low ambient control. Low ambient options already include pressure transducers on those specific systems. The two options listed directly before this option describe option combinations of low ambient and pressure transducer readout options.

Wall-Mount Zone Sensor, No Setpoint Adjustment – a 1 kOhm thin-film nickel zone sensor for wall mounting. This zone sensor is for sensing temperature only, and does not include any setpoint adjustment features.

Wall-Mount Zone Sensor, Scaled Setpoint Adjustment – a 1 kOhm thin-film nickel zone sensor for wall mounting. This zone sensor is for sensing temperature and includes a scaled temperature setpoint adjustment feature.

Wall-Mount Zone Sensor, Nonscaled Setpoint Adjustment – a 1 kOhm thin-film nickel zone sensor for wall mounting. This zone sensor is for sensing temperature and includes a non-scaled (warmer-cooler) setpoint adjustment feature.

BACNet IP Communications Card – for BAS communications, a BACNet card is available for ethernet connection.

BACNet MSTP Communications Card – for BAS communications, a BACNet MSTP card is available for an RS-485 connection.

IAQ OPTIONS

Filter Options – two-inch throwaway, cleanable, carbon or pleated filters in an angled rack are available. Additionally, twelve-inch 65% or 95% efficient rigid filters in a flat rack with two-inch prefilters. For field-supplied filters, the unit may be ordered with a rigid filter rack without filter media.

Manual Damper – economizer is available with a manual damper adjustable between 0-25 percent.

Two-Position – economizer is available with a two-position damper with the open position manually adjustable between 0-25 percent. It is controlled via the occupied/unoccupied signal from the unit controller. In occupied mode, the economizer will be open and in the unoccupied mode, the dampers will be closed.

0-100% Modulating – modulating control of exhaust air to maintain building static pressure. Outdoor air and return air dampers are interlocked and positioned by fully modulating, solid state damper actuators. Control of the damper is via a dry bulb sensor, single or comparative enthalpy.

Airflow Measurement – airflow measurement is available for the Modulating Damper Economizer option listed above. Three options exist for airflow measurement; minimum, full and 25%/75% airflow. Minimum airflow measures airflow between 0 and the minimum ventilation airflow up to 25% outside air. 100% airflow measurement measures air flow from 0-100% of the outside airflow. A third option includes a two-stage airflow measurement; stage one 0-25% and stage two 25-100%.

CO² Sensors – carbon dioxide sensors for occupied space that operate demand ventilation control opening outside air dampers to ventilate building. Available with 0-100% modulating economizer.

RELIEF SYSTEM

Barometric Relief – building air exhaust shall be accomplished through barometric relief dampers installed in the return air plenum. The dampers will open relative

to the building pressure. The opening pressure shall be adjustable.

Power Exhaust – exhaust control options are on/off, modulating discharge damper, or VFD fan speed control. On units with non-modulating exhaust a barometric relief damper is included to prevent outside air from entering in the off cycle. Fans shall cycle on and off with building pressure. (On units with modulating exhaust, a field-installed static pressure sensor mounted in the conditioned space or return air duct is required for damper and VFD modulation.)

EVAPORATOR COIL PROTECTION

Copper Fins – provided in lieu of aluminum fins.

Pre-Coated Fins – an epoxy-coated aluminum fin stock to guard from corrosive agents and insulate against galvanic potential. Used for mild seashore or industrial locations.

CONDENSER COIL PROTECTION

Copper Fins – provided in lieu of aluminum fins. **Pre-Coated Fins** - an epoxy-coated aluminum fin stock to guard from corrosive agents and insulate against galvanic potential. Used for mild seashore or industrial locations.

Post-Coated Fins – Technicoat coil-coating process used on condenser coils for seashore and other corrosive applications (with the exception of strong alkalis, oxidizers, wet bromide, chlorine and fluorine in concentrations greater than 100ppm).

REFRIGERANT SYSTEM OPTIONS

Hot Gas Bypass – Permits continuous, stable operation at capacities below the minimum step of compressor staging to as low as 5% capacity (depending on both the unit and operating conditions) by introducing an artificial load to the evaporator coil. Hot gas bypass is standard on refrigerant system #1 on VAV units; available as an option on constant volume.

Replaceable Core Liquid Line Driers – liquid line driers are standard on the eco² rooftop unit. An option is provided for replaceable core driers.

Compressor Isolation Valves – optional ball valves installed in the compressor suction and discharge lines allow easier access to the compressors without having to remove the unit charge during compressor servicing.

Guide Specifications (continued)

ROOF CURBS

Full Perimeter Roof Curbs – 14" high roof curb with wood nailer. Roof curb supports the entire perimeter of the unit.

Partial perimeter roof curbs – 14" high roof curb with wood nailer. Roof curb supports the air handling section with a separate support under the condenser end.

ACCESSORIES

Compressor Sound Blankets – compressor acoustic sound blankets for sound sensitive applications.

Filter Switch – an optional dirty filter alarm can be provided that will provide an alarm when the filters require cleaning.

Return Air Temperature Sensor – this sensor when ordered separately can be used for readout through the OptiLogic controller, and it can be used as a backup in the event space temperature sensor fails for temporary unit operation. For units supplied with a comparative enthalpy economizer control, this option is already included. This sensor is included with heat options, and optional for units with cooling options. This sensor must be present for morning warm-up.

Condenser Coil Guard – this optional wire guard protects the condenser section from access and is used for unit aesthetics.

Louvered Panels – Louvered panels surround the front, back, and sides of the unit. These prevent unauthorized access and visually screen unit components. Unrestricted air flow is permitted through generously sized louvered openings. This option is applicable for any outdoor design ambient temperature up to 46.1°C. (Factory- or Field-mounted.)

SUPPLY FAN OPTIONS

Fan Skid Isolation – the entire supply fan assembly shall be isolated from the unit base with two-inch deflection springs, or one or two-inch deflection springs with seismic restraints.

Supply and Exhaust Fan Motors – high efficiency ODP, standard and high efficiency TEFC motors are available, all meeting the Energy Policy Act of 1992 (EPACT).

Supply Fan VFD and Manual Bypass – for VAV applications, VFDs are provided to modulate air flow. Optional manual bypass can also be provided to allow full airflow in the event of a VFD failure.

