

TECHNICAL GUIDE

PREDATOR[®]

HIGH EFFICIENCY SINGLE PACKAGE AIR CONDITIONERS AND SINGLE PACKAGE GAS/ELECTRIC UNITS

DH 078, 090, 102, 120 and 150

6-1/2, 7-1/2, 8-1/2, 10 and 12-1/2 NOMINAL TONS

10.0-11.5 EER



Heating and Air Conditioning

DESCRIPTION

ASHRAE 90.1 COMPLIANT

YORK[®] Predator[®] units are convertible single packages with a common footprint cabinet and common roof curb for all 6-1/2 through 12-1/2 ton models. All units have two compressors with independent refrigeration circuits to provide 2 stages of cooling. The units were designed for light commercial applications and can be easily installed on a roof curb, slab, or frame.

All Predator[®] units are self-contained and assembled on rigid full perimeter base rails allowing for 3-way forklift access and overhead rigging. Every unit is completely charged, wired, piped, and tested at the factory to provide a quick and easy field installation.

All units are convertible between side and down airflow. Independent economizer designs are used on side and down discharge applications, as well as all tonnage sizes.

Predator[®] units are available in the following configurations: cooling only, cooling with electric heat, and cooling with gas heat. Electric heaters are available as factory-installed options or field-installed accessories.

Tested in accordance with:



TABLE OF CONTENTS

DESCRIPTION	1	<u>Tbl. #</u>	<u>Pg. #</u>
FEATURES	3	12 ELECTRICAL DATA DH090 (7-1/2 TON) HIGH EFFICIENCY W/O PWRD CONVENIENCE OUTLET ..	22
FACTORY INSTALLED OPTIONS	5	13 ELECTRICAL DATA DH090 (7-1/2 TON) HIGH EFFICIENCY WITH PWRD CONVENIENCE OUTLET ..	22
FIELD INSTALLED ACCESSORIES	6	14 ELECTRICAL DATA DH102 (8-1/2 TON) HIGH EFFICIENCY W/O PWRD CONVENIENCE OUTLET ..	23
NOMENCLATURE	10	15 ELECTRICAL DATA DH102 (8-1/2 TON) HIGH EFFICIENCY WITH PWRD CONVENIENCE OUTLET ..	23
GUIDE SPECIFICATIONS	47	16 ELECTRICAL DATA DH120 (10 TON) HIGH EFFICIENCY W/O PWRD CONVENIENCE OUTLET	24

LIST OF FIGURES

<u>Fig. #</u>		<u>Pg. #</u>	
1	PREDATOR® COMPONENT LOCATION (DH120 SHOWN)	3	17 ELECTRICAL DATA DH120 (10 TON) HIGH EFFICIENCY WITH PWRD CONVENIENCE OUTLET
2	POWER EXHAUST ACCESSORY DOWNFLOW APPLICATION	38	18 ELECTRICAL DATA DH150 (12-1/2 TON) HIGH EFFICIENCY W/O PWRD CONVENIENCE OUTLET ..
3	POWER EXHAUST ACCESSORY HORIZONTAL APPLICATION	38	19 ELECTRICAL DATA DH150 (12-1/2 TON) HIGH EFFICIENCY W/PWRD CONVENIENCE OUTLET
4	UNIT 4 POINT LOAD	39	20 ELECTRIC HEAT MULTIPLIERS
5	UNIT CENTER OF GRAVITY	39	21 DH078 (6-1/2) SIDE SHOT BLOWER PERFORMANCE
6	UNIT 6 POINT LOAD	39	22 DH090 (7-1/2 TON) SIDE SHOT BLOWER PERFORMANCE
7	UNIT DIMENSIONS	40	23 DH102 (8-1/2 TON) SIDE SHOT BLOWER PERFORMANCE
8	PREDATOR® ROOF CURB DIMENSIONS	41	24 DH120 (10 TON) SIDE SHOT BLOWER PERFORMANCE
9	SUNLINE™ TO PREDATOR® TRANSITION ROOF CURBS	41	25 DH150 (12-1/2 TON) SIDE SHOT BLOWER PERFORMANCE
10	BOTTOM DUCT OPENINGS	42	26 DH078 (6-1/2 TON) DOWN SHOT BLOWER PERFORMANCE
11	REAR DUCT DIMENSIONS	42	27 DH090 (7-1/2 TON) DOWN SHOT BLOWER PERFORMANCE
12	DOWNFLOW ECONOMIZER HOOD DETAIL	43	28 DH102 (8-1/2 TON) DOWN SHOT BLOWER PERFORMANCE
13	COOLING UNIT WITH GAS HEAT WIRING 230 VOLT DIAGRAM	44	29 DH120 (10 TON) DOWN SHOT BLOWER PERFORMANCE
14	COOLING UNIT WITH/WITHOUT ELECTRIC HEAT WIRING DIAGRAM	45	30 DH150 (12-1/2 TON) DOWN SHOT BLOWER PERFORMANCE
15	COOLING UNIT WITH GAS HEAT WIRING 460, 575 VOLT 50 HZ DIAGRAM	46	31 ADDITIONAL STATIC RESISTANCE DH120 AND 150 .

LIST OF TABLES

<u>Tbl. #</u>		<u>Pg. #</u>	
1	ACCESSORIES	8	32 ADDITIONAL STATIC RESISTANCE DH078, 090, 102 .
2	DH PHYSICAL DATA	14	33 ELECTRIC HEAT MINIMUM SUPPLY AIR CFM
3	DH CAPACITY RATINGS	15	34 INDOOR BLOWER SPECIFICATIONS
4	UNIT VOLTAGE LIMITATIONS	15	35 POWER EXHAUST SPECIFICATIONS
5	COOLING CAPACITY DH078 (6-1/2 TON) UNIT	16	36 4 POINT LOAD WEIGHT
6	COOLING CAPACITY DH090 (7-1/2 TON) UNIT	17	37 6 POINT LOAD WEIGHT
7	COOLING CAPACITY DH102 (8-1/2 TON) UNIT	18	38 UNIT WEIGHT
8	COOLING CAPACITY DH120 (10 TON) UNIT	19	39 UNIT HEIGHT
9	COOLING CAPACITY DH150 (12-1/2 TON) UNIT	20	40 UNIT CLEARANCES
10	ELECTRICAL DATA DH078 (6-1/2 TON) HIGH EFFICIENCY W/O PWRD CONVENIENCE OUTLET ...	21	
11	ELECTRICAL DATA DH078 (6-1/2 TON) HIGH EFFICIENCY WITH PWRD CONVENIENCE OUTLET ..	21	

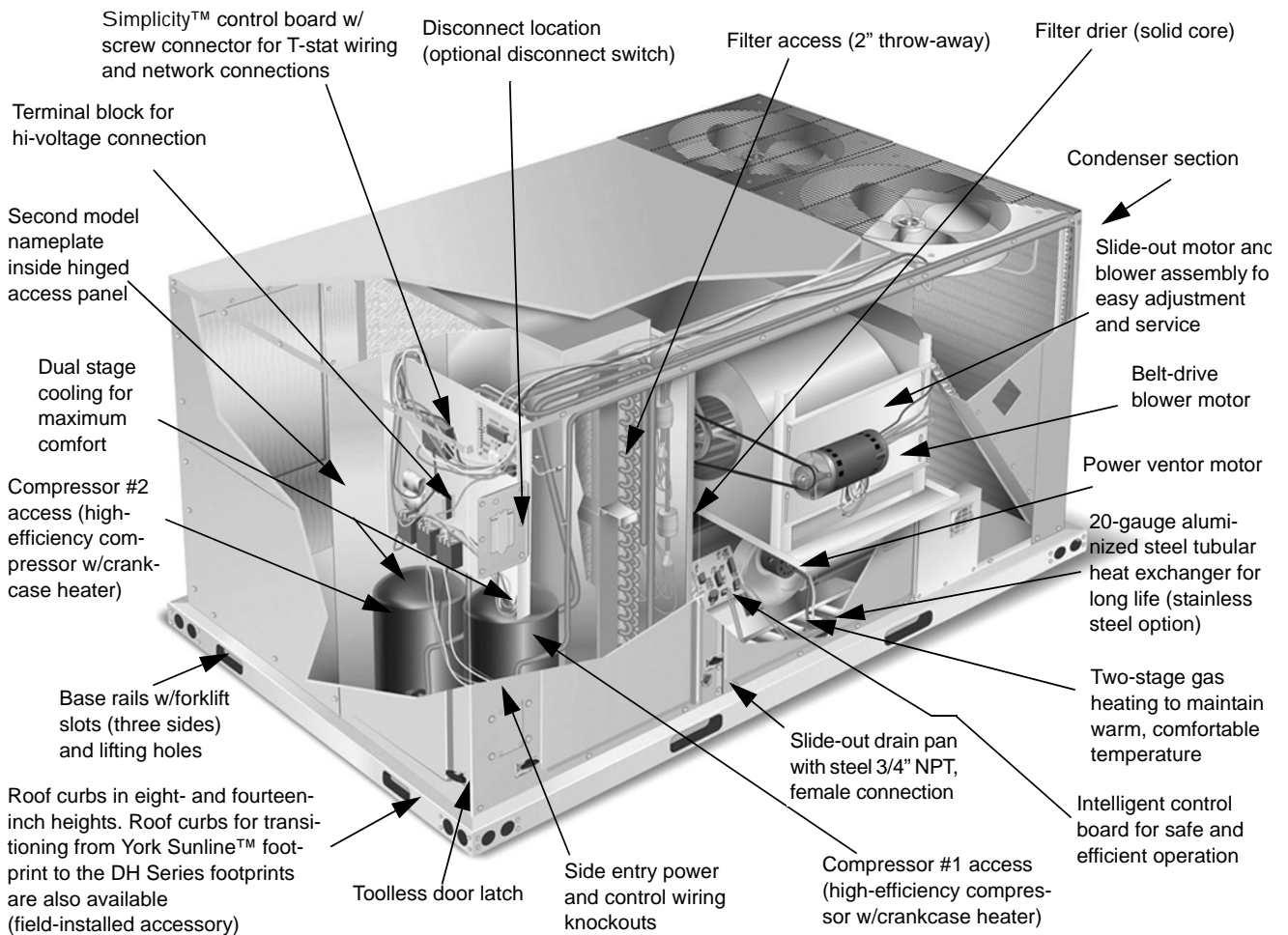

FIGURE 1 - PREDATOR® COMPONENT LOCATION (DH120 SHOWN)

FEATURES

- **High Efficiency** – High efficiency units reach as high as 11.5 EER. Gas/electric units have electronic spark ignition and power vented combustion with steady state efficiencies of 80%. These efficiencies exceed all legislated minimum levels and provide low operating costs.
- **Service Friendly** – The Predator® incorporates a number of enhancements which improve serviceability.

The motor and blower slide out of the unit as a common assembly. This facilitates greater access to all the indoor airflow components, thus simplifying maintenance and adjustment.

Service time is reduced through the use of hinged, toolless panels. Such panels provide access to frequently inspected components and areas, including the control box, compressors, filters, indoor motor & blower, and the heating section. The panels are screwed in place at the factory to prevent access by children or

other unauthorized persons. It is recommended that the panels be secured with screws once service is complete.

Service windows have been placed in both condenser section walls. Rotation of the cover allows easy access to the condenser coils for cleaning or inspection.

Both the unit control board and ignition control board utilize flash codes to aid in diagnosis of unit malfunctions. Unique alarm codes quickly identify the source of the unit alarm.

All units use the same standard filter size. This standardization removes any confusion on which filter sizes are needed for replacement.

The non-corrosive drain pan slides out of the unit to permit easy cleaning. The drain pan is accessed by removing the drain pan cover plate on the rear of the unit. Once the plate is removed, the drain pan slides out through the rear of the unit.

All Predator® units have a second model nameplate located inside the control access door. This is to prevent deterioration of the nameplate through weathering.

- **Environmentally Aware** – For improved Indoor Air Quality, foil faced insulation is used exclusively throughout the units.
- **Balanced Heating** – The Predator® offers “Ultimate Heating Comfort” with a balance between 1st and 2nd stage gas heating. The first stage of a gas heat Predator® unit provides 60% of the heating capacity. Balanced heating allows the unit to better maintain desired temperatures.
- **Convertible Airflow Design** – The side duct openings are covered when they leave the factory. If a side supply/return is desired, the installer simply removes the two side duct covers from the outside of the unit and installs them over the down shot openings. No panel cutting is required. Convertible airflow design allows maximum field flexibility and minimum inventory.
- **System Protection** - Suction line freezestats are supplied on all units to protect against loss of charge and coil frosting when the economizer operates at low outdoor air temperatures while the compressors are running. Every unit has solid-core liquid line filter-driers and high and low-pressure switches. Internal compressor protection is standard on all compressors. Crankcase heaters are standard on reciprocating compressors. Scroll compressors do not require crankcase heaters. Phase Monitors are standard on units with scroll compressors. This accessory monitors the incoming power to the unit and protects the unit from phase loss and reversed phase rotation.
- **Advanced Controls** - Simplicity™ control boards have standardized a number of features previously available only as options or by utilizing additional controls.
 - **Low Ambient** - An integrated low-ambient control allows all units to operate in the cooling mode down to 0°F outdoor ambient without additional assistance. Optionally, the control board can be programmed to lockout the compressors when the outdoor air temperature is low or when free cooling is available.
 - **Anti-Short Cycle Protection** - To aid compressor life, an anti-short cycle delay is incorporated into the standard controls. Compressor reliability is further ensured by programmable minimum run times. For testing, the anti-short cycle delay can be temporarily overridden with the push of a button.
 - **Fan Delays** - Fan on and fan off delays are fully programmable. Furthermore, the heating and cooling fan delay times are independent of one another. All units are programmed with default values based upon their configuration of cooling and heat.
 - **Safety Monitoring** - The control board monitors the high and low-pressure switches, the freezestats, the

gas valve, if applicable, and the temperature limit switch on gas and electric heat units. The unit control board will alarm on ignition failures, compressor lockouts and repeated limit switch trips.

- **Nuisance Trip Protection and Strikes** - To prevent nuisance trouble calls, the control board uses a “three times, you’re out” philosophy. The high and low-pressure switches and the freezestats must trip three times within two hours before the unit control board will lock out the associated compressor.
- **On Board Diagnostics** - Each alarm will energize a trouble light on the thermostat, if so equipped, and flash an alarm code on the control board LED. Each high and low-pressure switch alarm as well as each freezestat alarm has its own flash code. The control board saves the five most recent alarms in memory, and these alarms can be reviewed at any time. Alarms and programmed values are retained through the loss of power.
- **Reliable** – From the beginning – All units undergo computer automated testing before they leave the factory. Units are tested for refrigerant charge and pressure, unit amperage, and 100% functionality. For the long term – All Predator® units are painted with a long lasting, powder paint that stands up over the life of the unit. The paint used has been proven by a 1000 hour salt spray test.
- **Flexible Placement** – All models and configurations share the same cabinet/footprint and thus the same roof curb. You have the flexibility to set one curb and choose the correct tonnage size and heating option after the internal loads have been determined.

To further simplify planning and installation, Predator® cabinets are designed to fit your roof. With the optional roof curb, the unit ductwork is designed to fit around 24” on-center joists or between 48” on-center joists.

The drain pan can be rotated to drain to either the front or the rear of the unit. Additionally, the drain pan can be fitted to drain through the roof curb. As it is sometimes difficult to have a level installation, the drain pan features a generous slope to ensure proper drainage.

- **Full Perimeter Base Rails** – The permanently attached base rails provide a solid foundation for the entire unit and protect the unit during shipment. The rails offer fork-lift access from 3 sides, and rigging holes are available so that an overhead crane can be used to place the units on a roof.
- **Easy Installation** – Gas and electric utility knockouts are supplied in the unit underside as well as the side of the unit. A clearly identified location is provided to mount a field supplied electrical disconnect switch. Utility connections can be made quickly and with a minimum amount of field labor.

All units are shipped with 2” throw-away filters installed.

- **Wide Range of Indoor Airflows** – All indoor fan motors are belt-drive type providing maximum flexibility to handle most airflow requirements. For high static applications, factory installed alternate indoor fan motors are available. With the optional indoor fan motor, all units can supply nominal airflow at a minimum of 1.5" ESP.
- **Warranty** - All models include a 1-year limited warranty on the complete unit. Compressors and electric heater elements each carry a 5-year warranty. Aluminized steel and stainless steel tubular heat exchangers carry a 10-year warranty.

FACTORY INSTALLED OPTIONS

YORK® offers several equipment options factory installed, for the Predator® line.

- **Downflow Economizer - (With barometric relief)** - The economizer is provided with a single enthalpy input. The economizer is 2% low leakage type, and is shipped installed and wired. The installer needs only to assemble and mount the outdoor air hood (Provided). The economizer has spring return, fully modulating damper actuators and is capable of introducing up to 100% outdoor air. As the outdoor air intake dampers open, the return air dampers close. The changeover from mechanical refrigeration to economizer operation is regulated by the standard single enthalpy input. There is an optional input dual dry bulb available. To meet regulated air standards, the economizer control accepts an optional CO₂ input for demand ventilation. With single enthalpy input, the economizer control monitors outdoor air. The dual enthalpy kit provides a second input used to monitor the return air. With a dual input kit installed, the economizer control compares the values of the two enthalpy or temperature inputs and positions the dampers to provide the maximum efficiency possible.
- **Horizontal Economizer - (Without barometric relief)** - All features of the downflow economizer exist except you must order the duct mount barometric relief separately. **You must order a 1EH0408 if you are installing a power exhaust. You can order a 1RD0411 Barometric Relief for horizontal flow economizers only.**
- **BAS Ready Economizer -(With barometric relief)** - The economizer is provided with a Belimo actuator that requires a 0-10V DC input from an external source (i.e., field installed building automation system controller). Power exhaust options are available. The economizer is 2% low leakage type with spring return and fully modulating dampers capable of introducing up to 100% outside air. Also include 2" pleated filters.
- **Slab Economizer for Energy Recovery Ventilators-(With barometric relief and Fresh Air Hood)** - The economizer is provided with a single enthalpy input. The economizer is 2% low leakage type, and is shipped installed and wired. The economizer has spring return, fully modulating damper actuators and is capable of introducing up to 100% outdoor air. As the outdoor air intake dampers open, the return air dampers close. The changeover from mechanical refrigeration to economizer operation is regulated by the standard single enthalpy input. There is an optional input dual dry bulb available. To meet regulated air standards, the economizer control accepts an optional CO₂ input for demand ventilation. With single enthalpy input, the economizer control monitors outdoor air. The dual enthalpy kit provides a second input used to monitor the return air. With a dual input kit installed, the economizer control compares the values of the two enthalpy or temperature inputs and positions the dampers to provide the maximum efficiency possible.
- **Power Exhaust (Downflow only)** - This accessory installs in the unit with a down flow economizer.
- **Motorized Outdoor Air Damper** - The motorized outdoor air damper includes a slide-in/plug-in damper assembly with an outdoor air hood and filters. The outdoor air dampers open to the preset position when the indoor fan motor is energized. The damper has a range of 0% to 100% outdoor air entry. Factory installed option or field installed accessory.
- **Alternate Indoor Blower Motor** - For applications with high static restrictions, units are offered with optional indoor motors that provide higher static output and/or higher airflow, depending upon the installer's needs.
- **Aluminized Steel Gas Heat Exchanger** - For applications in non-corrosive environments.
- **Stainless Steel Gas Heat Exchanger** - For applications in corrosive environments, this option provides a full stainless steel heat exchanger assembly.
- **Stainless Steel Drain Pan** - An optional rust-proof stainless steel drain pan is available to provide years of trouble-free operation in corrosive environments.
- **Electric Heaters** - The electric heaters range from 9kW to 54kW and are available in all the voltage options of the base units. All heaters are dual staged. All heaters are intended for single point power supply.
- **Disconnect Switch** - For gas heat units and cooling units with electric heat, a HACR breaker sized to the unit is provided. For cooling only units, a switch sized to the largest electric heat available for the particular unit is provided. Factory installed option only.
- **Convenience Outlet - (Non-Powered/Powered)** - This option locates a 120V single-phase GFCI outlet with cover, on the corner of the unit housing adjacent to the compressors. The "Non-powered" option requires the installer to provide the 120V single-phase power source and wiring. The "Powered" option is powered by a step-down transformer in the unit. Factory installed option only.
- **Smoke Detectors** - The smoke detectors stop operation of the unit by interrupting power to the control board if smoke is detected within the air compartment. Available for both the supply and/or return air.

- **Phase Monitors** - Designed to prevent unit damage. The phase monitor will shut the unit down in an out-of-phase condition. **(Standard on units with Scroll Compressors.)**
- **Coil Guard** - Customers can purchase a coil guard kit to protect the condenser coil from damage. Additionally, this kit stops animals and foreign objects from entering the space between the inner condenser coil and the main cabinet. This is not a hail guard kit.
- **Dirty Filter Switch** - This kit includes a differential pressure switch that energizes the fault light on the unit thermostat, indicating that there is an abnormally high pressure drop across the filters. Factory installed option or field installed accessory.
- **Technicoat Condenser Coils** - The condenser coils are coated with a phenolic coating for protection against corrosion due to harsh environments.
- **Technicoat Evaporator Coil** - The evaporator coils are coated with a phenolic coating for protection against corrosion due to harsh environments.
- **BAS - Building Automation System Controls Simplicity™ INTELLI-Comfort™ Control** - The York® Simplicity™ INTELLI-Comfort™ control is factory installed. It includes a supply air sensor, a return air sensor, and an outside air sensor. There are provisions for a field installed dirty filter indicator switch, an air-proving switch, an Outside Air Humidity sensor, a Return Air Humidity sensor, an Inside IAQ sensor, and an Outside Air IAQ sensor. Construction mode operation, 365-day real time clock with 7 day programming plus holiday scheduling is built-in. Two different modes of demand ventilation are achieved through the INTELLI-Comfort™ using CO₂ sensors. It uses an inside CO₂ sensor to perform Demand Ventilation. It can also use an Outside CO₂ sensor to perform Differential Demand Ventilation. It uses a Patented Comfort Ventilation algorithm to provide comfortable ventilation air temperature. The patented economizer-loading algorithm will protect the equipment when harsh operating conditions exist. Humidity in the occupied space or return duct can be monitored and controlled via humidity sensors and the on-board connection for hot gas re-heat system. It uses the INTELLI-Start™ algorithm to maximize energy savings by recovering the building from the Unoccupied Setpoints to the Occupied Setpoints just in time for the Occupied Time Period to begin. The Simplicity™ INTELLI-Comfort™ balances space temperature, ventilation air temperature, CO₂ and humidity for ultimate comfort.
- **Simplicity™ INTELLI-Comfort™ with ModLINC Control** - The York® Simplicity™ INTELLI-Comfort™ with ModLINC control is factory installed. It includes all the features of the INTELLI-Comfort™ control with an additional control to translate communications from MODBUS to the BACnet MSTP protocol.
- **Novar® BAS Control** - The Novar® ETC-3 building automation system controller is factory installed. Includes

supply air sensor, return air sensor, dirty filter indicator switch, and air proving switch.

- **Johnson Controls BAS Control** - The Johnson Control YK-UNT-1126 building automation system controller is factory installed. Includes supply air sensor, return air sensor, dirty filter indicator switch, and air proving switch.
- **CPC BAS Control** - The Computer Process Controls Model 810-3060 ARTC Advanced Rooftop building automation system controller is factory installed. Includes supply air sensor, return air sensor, dirty filter indicator switch and air proving switch.
- **Honeywell BAS Control** - The Honeywell W7750C building automation system controller is factory installed. Includes air supply sensor, return air sensor, dirty filter indicator switch, and air proving switch.

FIELD INSTALLED ACCESSORIES

YORK® offers several equipment accessories for field installation, for the Predator® line.

- **Downflow Economizer - (With barometric relief)** - The economizer is provided with a single enthalpy input. The economizer is 2% low leakage type. The economizer has spring return, fully modulating damper actuators and is capable of introducing up to 100% outdoor air. As the outdoor air intake dampers open, the return air dampers close. The changeover from mechanical refrigeration to economizer operation is regulated by the standard single enthalpy input. There is an optional input dual dry bulb available. To meet regulated air standards, the economizer control accepts an optional CO₂ input for demand ventilation. With single enthalpy input, the economizer control monitors outdoor air. The dual enthalpy kit provides a second input used to monitor the return air. With a dual input kit installed, the economizer control compares the values of the two enthalpy or temperature inputs and positions the dampers to provide the maximum efficiency possible
- **Horizontal Economizer - (Without barometric relief)** - All features of the downflow economizer exist except you must order the duct mount barometric relief separately. **You must order a 1EH0408 if you are installing a power exhaust. You can order a 1RD0411 Barometric Relief for horizontal flow economizer.**
- **Slab Economizer for Energy Recovery Ventilator - (Without barometric relief or Fresh Air Hood)** - The economizer is provided with a single enthalpy input. The economizer is 2% low leakage type. The economizer has spring return, fully modulating damper actuators and is capable of introducing up to 100% outdoor air. As the outdoor air intake dampers open, the return air dampers close. The changeover from mechanical refrigeration to economizer operation is regulated by the standard single enthalpy input. There is an optional input dual dry bulb available. To meet regulated air standards, the economizer control accepts an optional CO₂ input for demand

ventilation. With single enthalpy input, the economizer control monitors outdoor air. The dual enthalpy kit provides a second input used to monitor the return air. With a dual input kit installed, the economizer control compares the values of the two enthalpy or temperature inputs and positions the dampers to provide the maximum efficiency possible.

You can order 1EH0409 Barometric Relief/FA Hood for field installations without an ERV.

- **Dual Enthalpy Control, Accessory** - This kit contains the required components to convert a single enthalpy economizer to dual enthalpy.
- **Barometric Relief Damper** - Zero to 100% capacity barometric relief dampers for use with horizontal flow, or field installed slab economizers.
- **Power Exhaust** - This accessory installs in the unit with a down flow economizer. Power exhaust plugs into the connector in the unit bulkhead. **You must purchase 1EH0408 barometric relief when applying to a horizontal flow application.**
- **Manual Outdoor Air Damper** - Like the motorized outdoor air damper, each manual outdoor air damper includes a slide-in damper assembly with an outdoor air hood and filters. Customers have a choice of dampers with ranges of 0% to 100% or 0% to 35% outdoor air entry.
- **Motorized Outdoor Air Damper** - The motorized outdoor air damper includes a slide-in/plug-in damper assembly with an outdoor air hood and filters. The outdoor air dampers open to the preset position when the indoor fan motor is energized. The damper has a range of 0% to 100% outdoor air entry. Factory installed option or field installed accessory.
- **Smoke Detectors** - The smoke detectors stop operation of the unit by interrupting power to the control board if smoke is detected within the air compartment.
- **CO₂ Sensor** - Senses CO₂ levels and automatically overrides the economizer when levels rise above the preset limits.
- **Dirty Filter Switch** - This kit includes a differential pressure switch that energizes the fault light on the unit thermostat, indicating that there is an abnormally high pressure drop across the filters.
- **Coil Guard** - Field installed decorative wire coil guard.
- **Hail Guard** - This kit includes a sloped hood which installs over the outside condenser coil and prevents damage to the coil fins from hail strikes. Field installed accessory only.
- **Flue Exhaust Extension Kit** - In locations with wind or weather conditions which may interfere with proper exhausting of furnace combustion products, this kit can be installed to prevent the flue exhaust from entering nearby fresh air intakes.
- **-60°F Gas Heat Kit** - For installations which require gas heat units to perform in low ambient temperatures, a gas section heating kit is available. This kit provides electric heat in the gas heat controls section to ensure the gas valve and controls will continue to function properly at extremely low temperatures.
- **Gas Heat High Altitude Kit** - This kit converts a gas heat unit to operate at high altitudes, 2,000 to 6,000 feet. Conversion kits are available for natural gas and propane.
- **Gas Heat Propane Conversion Kit** - This kit converts a gas-fired heater from natural gas to propane. It contains the main burner orifices and gas valve replacement springs.
- **Gas Piping Kit** - Contains pipe nipples, fittings and gas cock required for gas supply connection with external shut off.
- **Electric Heaters** - The electric heaters range from 9 kW to 54kW and are available in all the voltage options of the base units. All heaters are dual staged. Cooling units include an adapter panel for easy installation of the electric heaters. Necessary hardware and connectors are included with the heaters. All heaters are intended for single point power supply.
- **Low Limit / Compressor Lockout Kit**
 1. **Compressor Lockout (CLO):** To prevent mechanical (compressorized) operation of the unit during cold outdoor conditions where there is a risk of returning liquid refrigerant back to the compressors.
 2. **Low Limit Control (LLC):** To prevent the supply air from dropping below a specified setpoint by utilizing the units first stage heating means when there is a demand for cooling during cold outside conditions.
- **Metal Frame Filter Kit** - Metal frame with polyester filter medium.
- **Permanent Filters** - Permanent filters are available.
- **Roof Curbs** - The roof curbs have insulated decks and are shipped disassembled. The roof curbs are available in 8" and 14" heights. For applications with security concerns, burglar bars are available for the duct openings of the roof curbs.
- **Roof Curb Transition** - Single Piece Adapter (10" High) - Roof curbs for transitioning from Sunline™ units to Predator® units. Fits 7.5 to 12.5 Sunline™ roof curbs only.
- **Burglar Bars** - Mount in the supply and return openings to prevent entry into the duct work.
- **Thermostat** - The units are designed to operate with 24-volt electronic and electro-mechanical thermostats. All units (with or without an economizer) operate with two-stage heat/two-stage cool or two-stage cooling only thermostats, depending upon unit configuration.

TABLE 1: ACCESSORIES

Part Number	Description	Weight
1RC0470	Roof Curb, 8" Height	-
1RC0471	Roof Curb, 14" Height	-
1RC0472	Roof Curb, Transition (7.5 T through 12.5 T)	-
1BD0408	Burglar Bars, Downflow	-
2TP04520925	Electric Heat 9kW 230V	-
2TP04521825	Electric Heat 18kW 230V	-
2TP04522425	Electric Heat 24kW 230V	-
2TP04523625	Electric Heat 36kW 230V	-
2TP04525425	Electric Heat 54kW 230V	-
2TP04520946	Electric Heat 9kW 460V	-
2TP04521846	Electric Heat 18kW 460V	-
2TP04522446	Electric Heat 24kW 460V	-
2TP04523646	Electric Heat 36kW 460V	-
2TP04525446	Electric Heat 54kW 460V	-
2TP04520958	Electric Heat 9kW 575V	-
2TP04521858	Electric Heat 18kW 575V	-
2TP04522458	Electric Heat 24kW 575V	-
2TP04523658	Electric Heat 36kW 575V	-
2TP04525458	Electric Heat 54kW 575V	-
2TP04540925	Electric Heat 9kW 230V, 42" Tall Cabinet	-
2TP04541825	Electric Heat 18kW 230V, 42" Tall Cabinet	-
2TP04542425	Electric Heat 24kW 230V, 42" Tall Cabinet	-
2TP04543625	Electric Heat 36kW 230V, 42" Tall Cabinet	-
2TP04540946	Electric Heat 9kW 460V, 42" Tall Cabinet	-
2TP04541846	Electric Heat 18kW 460V, 42" Tall Cabinet	-
2TP04542446	Electric Heat 24kW 460V, 42" Tall Cabinet	-
2TP04543646	Electric Heat 36kW 460V, 42" Tall Cabinet	-
2TP04540958	Electric Heat 9kW 575V, 42" Tall Cabinet	-
2TP04541858	Electric Heat 18kW 575V, 42" Tall Cabinet	-
2TP04542458	Electric Heat 24kW 575V, 42" Tall Cabinet	-
2TP04543658	Electric Heat 36kW 575V, 42" Tall Cabinet	-
1FA0411	Manual Outside Air Damper 0-35%, Downflow (Incl. Hood, Damper & Filters, No Barometric Relief)	-
1FA0412	Manual Outside Air Damper 0-100%, Downflow (Incl. Hood, Damper & Filters, No Barometric Relief)	-
2MD04702724	Motorized Damper, Downflow (Incl. Hood, Damper & Filter, no Barometric Relief)	-
2MD04703324	Motorized Damper, Horizontal (Incl. Hood, Damper & Filter, no Barometric Relief)	-
2EE04705424	Economizer, Downflow (Incl. Barometric Relief & All Hoods)	124 lbs.
2EE04705524	Economizer, Horizontal (Incl. Dampers & Hoods, no Barometric Relief)	97 lbs.
2EE04705224	Economizer, Slab, Downflow (Incl. Dampers only no Hoods or Barometric Relief)	-
2EE04705624	"Downflow Economizer, Slab type for ERV (no Barometric Relief or FA hood)", 42" Tall Cabinet	-
2PE04703225	Power Exhaust, Downflow, 230V (For Units with Economizer only)	-
2PE04703246	Power Exhaust, Downflow, 460V(For Units with Economizer only)	-
2PE04703258	Power Exhaust, Downflow, 580V (For Units with Economizer only)	-
2EC04700924	Dual Enthalpy Control (Use with Single Enthalpy Economizer)	-
1EH0407	Hood Kit, Downflow Economizer (Included with all Downflow Economizers)	-
1RD0411	Barometric Relief Kit, Ductmount for Horizontal Application (Incl. Damper & Hood)	-
1EH0408	Barometric Relief Kit, Ductmount for Horizontal Application w/Power Exhaust (Incl. Damper & Hood)	25 lbs.
1EH0409	Barometric Relief / Hood Kit, for Field Installed Slab Econ. w/o ERV (Incl. Barometric Relief & FA Hood)	-
2AQ04700424	CO2 Detector Unit Mount	-
2AQ04700324	CO2 Detector Space Mount	-
2SD04700424	Smoke Detector, Supply or Return (Return Not Available with Horizontal Economizer)	-
2MK04700624	Low Limit / Compressor Lockout Kit	-
1CG0419	Coil Guard (Electric / Electric & HP models)	-

TABLE 1: ACCESSORIES (CONTINUED)

Part Number	Description	Weight
1CG0420	Coil Guard (Gas / Electric models)	-
1CG0427	Coil Guard (Electric / Electric & HP Models), 42" Tall Cabinet	-
1CG0428	Coil Guard (Gas / Electric Models), 42" Tall Cabinet	-
1HG0411	Hail Guard Kit	-
1HG0415	Hail Guard Kit, 42" Tall Cabinet	-
1GP0405	Gas Piping Kit	-
1NP0442	Propane Conversion Kit	-
1HA0442	High Altitude Kit for Natural Gas	-
1HA0443	High Altitude Kit for Propane	-
1FE0412	Flue Exhaust Extension Kit	-
2BC04700106	Gas Heat Kit, -60 deg F, 230V	-
2BC04700151	Gas Heat Kit, -60 deg F, 460V	-
2BC04700154	Gas Heat Kit, -60 deg F, 575V	-
1FL0402	Permanent Filter Kit	-
1FL0423	Permanent Filter Kit, 42" Tall Cabinet	-
2DF0401	Dirty Filter Switch	-
1FF0410	Filter Frame Kit, Metal	-
1FF0411	Metal Filter Frame Kit, 42" Tall Cabinet	-

NOMENCLATURE

6½ - 12½ Ton Predator Model Number Nomenclature

D H 090 N10 A 2 A AA 3

Product Category
D = Air Cond., Single Package

Product Identifier
H = R-22 High Efficiency

Nominal Cooling Capacity - MBH
078 = 6-½ Ton
090 = 7-½ Ton
102 = 8-½ Ton
120 = 10 Ton
150 = 12-½ Ton

Heat Type & Nominal Heat Capacity
C00 = Cooling Only. Suitable for field installed electric heat

Gas Heat Options
N 10 = 100 MBH Output Aluminized Steel
N 15 = 150 MBH Output Aluminized Steel
N 20 = 200 MBH Output Aluminized Steel
S 10 = 100 MBH Output Stainless Steel
S 15 = 150 MBH Output Stainless Steel
S 20 = 200 MBH Output Stainless Steel

Electric Heat Options
E09 = 9 kW Electric Heat
E18 = 18 kW Electric Heat
E24 = 24 kW Electric Heat
E36 = 36 kW Electric Heat
E54 = 54 kW Electric Heat

Voltage
2 = 208/230-3-60
4 = 460-3-60
5 = 575-3-60

Installation Options
A = No Options Installed
B = Option 1
C = Option 2
D = Options 1 & 2
E = Option 3
F = Option 4
G = Options 1 & 3
H = Options 1 & 4
J = Options 1, 2 & 3
K = Options 1, 2 & 4
L = Options 1, 3 & 4
M = Options 1, 2, 3 & 4
N = Options 2 & 3
P = Options 2 & 4
Q = Options 2, 3 & 4
R = Options 3 & 4
S = Option 5
T = Options 1 & 5
U = Options 1, 3 & 5
V = Options 1, 4 & 5
W = Options 1, 3, 4 & 5
X = Options 3 & 5
Y = Options 4 & 5
Z = Options 3, 4 & 5

Options
1 = Disconnect
2 = Non-Pwr'd Conv Outlet
3 = Smoke Detector S. A.
4 = Smoke Detector R. A.
5 = Pwr'd Conv Outlet

Product Generation
3 = Third Generation
4 = Fourth Generation
5 = Fifth Generation

Additional Options
(See Next Page)

Airflow

A = Standard Motor
B = Standard Motor/Economizer/Barometric Relief (Downflow only)
C = Standard Motor/Economizer/Power Exhaust (Downflow only)
D = Standard Motor/Motorized Damper (Downflow only)
E = Standard Motor/Horizontal Economizer (No Barometric Relief)
F = Standard Motor/Slab Economizer/Power Exhaust (Downflow only)
G = Standard Motor/Slab Economizer/Barometric Relief (Downflow only)
L = Standard Motor/BAS Ready Econ (NoBASController)/Barometric Relief w/2" Pleated Filters (Downflow only)
M = Standard Motor/BAS Ready Econ (NoBASController)/Power Exhaust w/2" Pleated Filters (Downflow only)
N = High Static Motor
P = High Static Motor/Economizer/Barometric Relief (Downflow only)
Q = High Static Motor/Economizer/Power Exhaust (Downflow only)
R = High Static Motor/Motorized Damper (Downflow only)
S = High Static Motor/Horizontal Economizer (No Barometric Relief)
T = High Static Motor/Slab Economizer/Power Exhaust (Downflow only)
U = High Static Motor/Slab Economizer/Barometric Relief (Downflow only)
Y = High Static Motor/BAS Ready Econ (NoBASController)/Barometric Relief w/2" Pleated Filters (Downflow only)
Z = High Static Motor/BAS Ready Econ (NoBASController)/Power Exhaust w/2" Pleated Filters (Downflow only)

NOMENCLATURE ADDITIONAL OPTIONS:

Additional Options	
AA	None
AB	Phase Monitor
AC	Coil Guard
AD	Dirty Filter Switch
AE	Phase Monitor & Coil Guard
AF	Phase Monitor & Dirty Filter Switch
AG	Coil Guard & Dirty Filter Switch
AH	Phase Monitor, Coil Guard, & Dirty Filter Switch
AJ	SS Drain Pan
AK	SS Drain Pan & Phase Monitor
AL	SS Drain Pan & Coil Guard
AM	SS Drain Pan & Dirty Filter Switch
AN	SS Drain Pan, Phase Monitor, Coil Guard & Dirty Filter Switch
CA	CPC Controller with Dirty Filter Switch & Air Proving Switch
CB	CPC Controller, DFS, APS & Phase Monitor
CC	CPC Controller, DFS, APS & Coil Guard
CD	CPC Controller, DFS, APS, Phase Monitor, & Coil Guard
CE	CPC Controller, DFS, APS & Technicoat Cond. Coil
CF	CPC Controller, DFS, APS, Technicoat Cond. Coil, & Phase Monitor
CG	CPC Controller, DFS, APS, Technicoat Cond. Coil, & Coil Guard
CH	CPC Controller, DFS, APS, Technicoat Cond. Coil, Phase Monitor, & Coil Guard
CJ	CPC Controller, DFS, APS & Technicoat Evap. Coil
CK	CPC Controller, DFS, APS, Technicoat Evap. Coil, & Phase Monitor
CL	CPC Controller, DFS, APS, Technicoat Evap. Coil, & Coil Guard
CM	CPC Controller, DFS, APS, Technicoat Evap. Coil, Phase Monitor, & Coil Guard
CN	CPC Controller, DFS, APS & Technicoat Evap. & Cond Coils
CP	CPC Controller, DFS, APS, Technicoat Evap. & Cond Coils, & Phase Monitor
CQ	CPC Controller, DFS, APS, Technicoat Evap. & Cond Coils, & Coil Guard
CR	CPC Controller, DFS, APS, Technicoat Evap. & Cond Coils, Phase Monitor, & Coil Guard
CS	CPC Controller, DFS, APS, SS Drain Pan
CT	CPC Controller, DFS, APS, SS Drain Pan, Phase Monitor, & Coil Guard
CU	CPC Controller, DFS, APS, SS Drain Pan, & Technicoat Cond Coils
CV	CPC Controller, DFS, APS, SS Drain Pan, & Technicoat Evap Coil
CW	CPC Controller, DFS, APS, SS Drain Pan, & Technicoat Evap and Cond Coils
CX	CPC Controller, DFS, APS, SS Drain Pan, Phase Monitor, Coil Guard, & Technicoat Evap and Cond Coils
JA	Johnson UNT Controller with Dirty Filter Switch & Air Proving Switch
JB	Johnson UNT Controller, DFS, APS & Phase Monitor
JC	Johnson UNT Controller, DFS, APS & Coil Guard
JD	Johnson UNT Controller, DFS, APS, Phase Monitor, & Coil Guard
JE	Johnson UNT Controller, DFS, APS & Technicoat Cond. Coil
JF	Johnson UNT Controller, DFS, APS, Technicoat Cond. Coil, & Phase Monitor
JG	Johnson UNT Controller, DFS, APS, Technicoat Cond. Coil, & Coil Guard
JH	Johnson UNT Controller, DFS, APS, Technicoat Cond. Coil, Phase Monitor, & Coil Guard
JJ	Johnson UNT Controller, DFS, APS & Technicoat Evap. Coil
JK	Johnson UNT Controller, DFS, APS, Technicoat Evap. Coil, & Phase Monitor
JL	Johnson UNT Controller, DFS, APS, Technicoat Evap. Coil, & Coil Guard
JM	Johnson UNT Controller, DFS, APS, Technicoat Evap. Coil, Phase Monitor, & Coil Guard
JN	Johnson UNT Controller, DFS, APS & Technicoat Evap. & Cond Coils
JP	Johnson UNT Controller, DFS, APS, Technicoat Evap. & Cond Coils, & Phase Monitor
JQ	Johnson UNT Controller, DFS, APS, Technicoat Evap. & Cond Coils, & Coil Guard
JR	Johnson UNT Controller, DFS, APS, Technicoat Evap. & Cond Coils, Phase Monitor, & Coil Guard
JS	Johnson UNT Controller, DFS, APS, SS Drain Pan
JT	Johnson UNT Controller, DFS, APS, SS Drain Pan, Phase Monitor, & Coil Guard
JU	Johnson UNT Controller, DFS, APS, SS Drain Pan, & Technicoat Cond Coils
JV	Johnson UNT Controller, DFS, APS, SS Drain Pan, & Technicoat Evap Coil
JW	Johnson UNT Controller, DFS, APS, SS Drain Pan, & Technicoat Evap and Cond Coils
JX	Johnson UNT Controller, DFS, APS, SS Drain Pan, Phase Monitor, Coil Guard, & Technicoat Evap and Cond Coils
HA	Honeywell Excel 10 Controller with Dirty Filter Switch & Air Proving Switch

Additional Options	
HB	Honeywell Excel 10 Controller, DFS, APS & Phase Monitor
HC	Honeywell Excel 10 Controller, DFS, APS & Coil Guard
HD	Honeywell Excel 10 Controller, DFS, APS, Phase Monitor, & Coil Guard
HE	Honeywell Excel 10 Controller, DFS, APS & Technicoat Cond. Coil
HF	Honeywell Excel 10 Controller, DFS, APS, Technicoat Cond. Coil, & Phase Monitor
HG	Honeywell Excel 10 Controller, DFS, APS, Technicoat Cond. Coil, & Coil Guard
HH	Honeywell Excel 10 Controller, DFS, APS, Technicoat Cond. Coil, Phase Monitor, & Coil Guard
HJ	Honeywell Excel 10 Controller, DFS, APS & Technicoat Evap. Coil
HK	Honeywell Excel 10 Controller, DFS, APS, Technicoat Evap. Coil, & Phase Monitor
HL	Honeywell Excel 10 Controller, DFS, APS, Technicoat Evap. Coil, & Coil Guard
HM	Honeywell Excel 10 Controller, DFS, APS, Technicoat Evap. Coil, Phase Monitor, & Coil Guard
HN	Honeywell Excel 10 Controller, DFS, APS & Technicoat Evap. & Cond Coils
HP	Honeywell Excel 10 Controller, DFS, APS, Technicoat Evap. & Cond Coils, & Phase Monitor
HQ	Honeywell Excel 10 Controller, DFS, APS, Technicoat Evap. & Cond Coils, & Coil Guard
HR	Honeywell Excel 10 Controller, DFS, APS, Technicoat Evap. & Cond Coils, Phase Monitor, & Coil Guard
HS	Honeywell Excel 10 Controller, DFS, APS, SS Drain Pan
HT	Honeywell Excel 10 Controller, DFS, APS, SS Drain Pan, Phase Monitor, & Coil Guard
HU	Honeywell Excel 10 Controller, DFS, APS, SS Drain Pan, & Technicoat Cond Coils
HV	Honeywell Excel 10 Controller, DFS, APS, SS Drain Pan, & Technicoat Evap Coil
HW	Honeywell Excel 10 Controller, DFS, APS, SS Drain Pan, & Technicoat Evap and Cond Coils
HX	Honeywell Excel 10 Controller, DFS, APS, SS Drain Pan, Phase Monitor, Coil Guard, & Technicoat Evap and Cond Coils
WA	Intelli-Comfort w/ModLINC Controller
WB	Intelli-Comfort w/ModLINC Controller, & Phase Monitor
WC	Intelli-Comfort w/ModLINC Controller, & Coil Guard
WD	Intelli-Comfort w/ModLINC Controller, Phase Monitor, & Coil Guard
WE	Intelli-Comfort w/ModLINC Controller, & Technicoat Cond. Coil
WF	Intelli-Comfort w/ModLINC Controller, Technicoat Cond. Coil, & Phase Monitor
WG	Intelli-Comfort w/ModLINC Controller, Technicoat Cond. Coil, & Coil Guard
WH	Intelli-Comfort w/ModLINC Controller, Technicoat Cond. Coil, Phase Monitor, & Coil Guard
WJ	Intelli-Comfort w/ModLINC Controller, & Technicoat Evap. Coil
WK	Intelli-Comfort w/ModLINC Controller, Technicoat Evap. Coil, & Phase Monitor
WL	Intelli-Comfort w/ModLINC Controller, Technicoat Evap. Coil, & Coil Guard
WM	Intelli-Comfort w/ModLINC Controller, Technicoat Evap. Coil, Phase Monitor, & Coil Guard
WN	Intelli-Comfort w/ModLINC Controller, & Technicoat Evap. & Cond Coils
WP	Intelli-Comfort w/ModLINC Controller, Technicoat Evap. & Cond Coils, & Phase Monitor
WQ	Intelli-Comfort w/ModLINC Controller, Technicoat Evap. & Cond Coils, & Coil Guard
WR	Intelli-Comfort w/ModLINC Controller, Technicoat Evap. & Cond Coils, Phase Monitor, & Coil Guard
WS	Intelli-Comfort w/ModLINC Controller, SS Drain Pan
WT	Intelli-Comfort w/ModLINC Controller, SS Drain Pan, Phase Monitor, & Coil Guard
WU	Intelli-Comfort w/ModLINC Controller, SS Drain Pan, & Technicoat Cond Coils
WV	Intelli-Comfort w/ModLINC Controller, SS Drain Pan, & Technicoat Evap Coil
WW	Intelli-Comfort w/ModLINC Controller, SS Drain Pan, & Technicoat Evap and Cond Coils
WX	Intelli-Comfort w/ModLINC Controller, SS Drain Pan, Phase Monitor, Coil Guard, & Technicoat Evap and Cond Coils
NA	Novar ETC-3 Controller with Dirty Filter Switch & Air Proving Switch
NB	Novar ETC-3 Controller, DFS, APS & Phase Monitor
NC	Novar ETC-3 Controller, DFS, APS & Coil Guard
ND	Novar ETC-3 Controller, DFS, APS, Phase Monitor, & Coil Guard
NE	Novar ETC-3 Controller, DFS, APS & Technicoat Cond. Coil
NF	Novar ETC-3 Controller, DFS, APS, Technicoat Cond. Coil, & Phase Monitor
NG	Novar ETC-3 Controller, DFS, APS, Technicoat Cond. Coil, & Coil Guard
NH	Novar ETC-3 Controller, DFS, APS, Technicoat Cond. Coil, Phase Monitor, & Coil Guard
NJ	Novar ETC-3 Controller, DFS, APS & Technicoat Evap. Coil
NK	Novar ETC-3 Controller, DFS, APS, Technicoat Evap. Coil, & Phase Monitor
NL	Novar ETC-3 Controller, DFS, APS, Technicoat Evap. Coil, & Coil Guard
NM	Novar ETC-3 Controller, DFS, APS, Technicoat Evap. Coil, Phase Monitor, & Coil Guard
NN	Novar ETC-3 Controller, DFS, APS & Technicoat Evap. & Cond Coils
NP	Novar ETC-3 Controller, DFS, APS, Technicoat Evap. & Cond Coils, & Phase Monitor
NQ	Novar ETC-3 Controller, DFS, APS, Technicoat Evap. & Cond Coils, & Coil Guard
NR	Novar ETC-3 Controller, DFS, APS, Technicoat Evap. & Cond Coils, Phase Monitor, & Coil Guard

Additional Options	
NS	Novar ETC-3 Controller, DFS, APS, SS Drain Pan
NT	Novar ETC-3 Controller, DFS, APS, SS Drain Pan, Phase Monitor, & Coil Guard
NU	Novar ETC-3 Controller, DFS, APS, SS Drain Pan, & Technicoat Cond Coils
NV	Novar ETC-3 Controller, DFS, APS, SS Drain Pan, & Technicoat Evap Coil
NW	Novar ETC-3, DFS, APS, SS Drain Pan, & Technicoat Evap and Cond Coils
NX	Novar ETC-3 Controller, DFS, APS, SS Drain Pan, Phase Monitor, Coil Guard, & Technicoat Evap and Cond Coils
LA	Simplicity Intelli-Comfort Controller
LB	Simplicity Intelli-Comfort Controller, & Phase Monitor
LC	Simplicity Intelli-Comfort Controller, & Coil Guard
LD	Simplicity Intelli-Comfort Controller, Phase Monitor, & Coil Guard
LE	Simplicity Intelli-Comfort Controller, & Technicoat Cond. Coil
LF	Simplicity Intelli-Comfort Controller, Technicoat Cond. Coil, & Phase Monitor
LG	Simplicity Intelli-Comfort Controller, Technicoat Cond. Coil, & Coil Guard
LH	Simplicity Intelli-Comfort Controller, Technicoat Cond. Coil, Phase Monitor, & Coil Guard
LJ	Simplicity Intelli-Comfort Controller, & Technicoat Evap. Coil
LK	Simplicity Intelli-Comfort Controller, Technicoat Evap. Coil, & Phase Monitor
LL	Simplicity Intelli-Comfort Controller, Technicoat Evap. Coil, & Coil Guard
LM	Simplicity Intelli-Comfort Controller, Technicoat Evap. Coil, Phase Monitor, & Coil Guard
LN	Simplicity Intelli-Comfort Controller, & Technicoat Evap. & Cond Coils
LP	Simplicity Intelli-Comfort Controller, Technicoat Evap. & Cond Coils, & Phase Monitor
LQ	Simplicity Intelli-Comfort Controller, Technicoat Evap. & Cond Coils, & Coil Guard
LR	Simplicity Intelli-Comfort Controller, Technicoat Evap. & Cond Coils, Phase Monitor, & Coil Guard
LS	Simplicity Intelli-Comfort Controller, SS Drain Pan
LT	Simplicity Intelli-Comfort Controller, SS Drain Pan, Phase Monitor, & Coil Guard
LU	Simplicity Intelli-Comfort Controller, SS Drain Pan, & Technicoat Cond Coils
LV	Simplicity Intelli-Comfort Controller, SS Drain Pan, & Technicoat Evap Coil
LW	Simplicity Intelli-Comfort Controller, SS Drain Pan, & Technicoat Evap and Cond Coils
LX	Simplicity Intelli-Comfort Controller, SS Drain Pan, Phase Monitor, Coil Guard, & Technicoat Evap and Cond Coils
TA	Technicoat Condenser Coil
TB	Technicoat Condenser Coil & Phase Monitor
TC	Technicoat Condenser Coil & Coil Guard
TD	Technicoat Condenser Coil & Dirty Filter Switch
TE	Technicoat Condenser Coil, Phase Monitor, & Coil Guard
TF	Technicoat Condenser Coil, Phase Monitor, & Dirty Filter Switch
TG	Technicoat Condenser Coil, Coil Guard, & Dirty Filter Switch
TH	Technicoat Condenser Coil, Phase Monitor, Coil Guard, & Dirty Filter Switch
TJ	Technicoat Evaporator Coil
TK	Technicoat Evaporator Coil & Phase Monitor
TL	Technicoat Evaporator Coil & Coil Guard
TM	Technicoat Evaporator Coil & Dirty Filter Switch
TN	Technicoat Evaporator Coil, Phase Monitor, & Coil Guard
TP	Technicoat Evaporator Coil, Phase Monitor, & Dirty Filter Switch
TQ	Technicoat Evaporator Coil, Coil Guard, & Dirty Filter Switch
TR	Technicoat Evaporator Coil, Phase Monitor, Coil Guard, & Dirty Filter Switch
TS	Technicoat Evaporator & Condenser Coils
TT	Technicoat Evaporator & Condenser Coils & Phase Monitor
TU	Technicoat Evaporator & Condenser Coils & Coil Guard
TV	Technicoat Evaporator & Condenser Coils & Dirty Filter Switch
TW	Technicoat Evaporator & Condenser Coils, Phase Monitor, & Coil Guard
TX	Technicoat Evaporator & Condenser Coils, Phase Monitor, & Dirty Filter Switch
TY	Technicoat Evaporator & Condenser Coils, Coil Guard, & Dirty Filter Switch
TZ	Technicoat Evaporator & Condenser Coils, Phase Monitor, Coil Guard, & Dirty Filter Switch
T1	Technicoat Condenser & SS Drain Pan
T3	Technicoat Condenser Coil, SS Drain Pan, Phase Monitor, Coil Guard, & Dirty Filter Switch
T4	Technicoat Evaporator & SS Drain Pan
T6	Technicoat Evaporator Coil, SS Drain Pan, Phase Monitor, Coil Guard, & Dirty Filter Switch
T7	Technicoat Evaporator & Condenser Coils & SS Drain Pan
T9	Technicoat Evaporator & Condenser Coils, SS Drain Pan, Phase Monitor, Coil Guard, & Dirty Filter Switch

TABLE 2: DH PHYSICAL DATA

Component		Models				
		078	090	102	120	150
Evaporator Blower	Blower, Centrifugal (Dia. X Wd. in.)	12 x 12	12 x 12	12 X 12	15 x 15	15 x 15
	Motor, Standard (HP)	1-1/2	2	3	2	3
	Motor, Optional (HP)	2	3	3	3	5
Evaporator Coil	Rows	3	3	3	4	4
	Fins per Inch	15	15	15	15	15
	Height (in.)	32	32	32	40	40
	Face Area (ft. ² each)	10.67	10.67	10.67	13.2	13.2
Condenser Fan (2 per Unit)	Propeller Dia. (in., each)	24	24	24	24	24
	Motor (HP, each)	1/3	1/3	1/3	3/4	3/4
	CFM, Nominal (each)	3400	3400	3400	4400	4400
Condenser Coil (2 per unit)	Rows (each)	Sys 1: 2 Row	2	2	2	2
		Sys 2: 1 Row				
	Fins per Inch	20	20	20	20	20
	Height (in., each)	36	36	36	44	44
Face Area (ft. ² each)	12	12	12	14.5	14.5	
Refrigerant Charge	System 1 (lb./oz.)	8/0	8/12	9/8	12/0	9/14
	System 2 (lb./oz.)	4/12	9/0	8/2	11/0	9/4
Compressors	Quantity	2	2	2	2	2
	Type	Recip.	Recip	Recip.	Recip	Scroll
Air Filters	Size (Wd. x Ht. x Thickness in.)	25x16x2	25x16x2	25x16x2	25x20x2	25x20x2
	Number Per Unit	4	4	4	4	4

TABLE 3: DH CAPACITY RATINGS

Size (Tons)	Model	Cooling Capacity ARI Ratings ¹			CFM	Sound Rating (dB) ²	Nominal Electric Heat Capacity ³ (kW)	Gas Heat Capacity				Gas Line Size (in. OD)
		MBH	EER	IPLV				Input (MBH)	Output (MBH)	Seasonal Efficiency (%)	Temp. Rise (°F)	
078 (6-1/2)	Cooling Only						-	-	-	-	-	-
	Electric Heat	75	11.5	11.90	2421	84	9, 18, 24, 36	-	-	-	-	-
	Gas Heat						-	120	96	80	20-50	3/4
	Gas Heat						-	180	144	80	35-65	3/4
090 (7-1/2)	Cooling Only						-	-	-	-	-	-
	Electric Heat	89	11.5	12.0	3000	84	18, 36	-	-	-	-	-
	Gas Heat						-	120	96	80	15-45	3/4
	Gas Heat						-	180	144	80	30-60	3/4
102 (8-1/2)	Cooling Only						-	-	-	-	-	-
	Electric Heat	99	11.0	11.50	2692	84	9, 18, 24, 36	-	-	-	-	-
	Gas Heat						-	120	96	80	15-45	3/4
	Gas Heat						-	180	144	80	30-60	3/4
120 (10)	Cooling Only						-	-	-	-	-	-
	Electric Heat	115	11.0	11.70	3840	90	18, 24, 36, 54	-	-	-	-	-
	Gas Heat						-	180	144	80	20-50	3/4
	Gas Heat						-	240	192	80	35-65	3/4
150 (12-1/2)	Cooling Only						-	-	-	-	-	-
	Electric Heat	146	10.0	10.70	4100	90	18, 24, 36, 54	-	-	-	-	-
	Gas Heat						-	180	144	80	10-40	3/4
	Gas Heat						-	240	192	80	25-55	3/4

1 Rated at 95°F ambient 80°F dry bulb and 67°F wet bulb.

2 Rated in accordance with ARI 270 standard.

3 See Table 20.

TABLE 4: UNIT VOLTAGE LIMITATIONS

POWER RATING	MIN.	MAX.
208/230-3-60	187	252
460-3-60	432	504
575-3-60	540	630

TABLE 5: COOLING CAPACITY DH078 (6-1/2 TON) UNIT

Air On Evap. Coil		Temperature of Air on Condenser Coil 75°F									Temperature of Air on Condenser Coil 85°F										
CFM	WB (°F)	Tot. Cap. ¹ (MBH)	Tot. Input ² (kW)	Sensible Capacity (MBH) ¹ Return Dry Bulb (°F)								Tot. Cap. ¹ (MBH)	Tot. Input ² (kW)	Sensible Capacity (MBH) ¹ Return Dry Bulb (°F)							
				86	83	80	77	74	71	68	86			83	80	77	74	71	68		
1950	72	88.9	4.8	51.3	45.8	40.2	34.6	29.1	-	-	84.6	5.3	49.4	43.9	38.3	32.7	27.2	-	-		
	67	85.5	4.8	65.4	59.9	54.3	48.7	43.2	37.6	32.1	79.8	5.2	62.9	57.4	51.8	46.2	40.7	35.1	29.6		
	62	80.0	4.7	80.0	73.8	68.2	62.7	57.1	51.5	46.0	74.2	5.1	74.2	69.8	64.3	58.7	53.1	47.6	42.0		
2275	57	78.2	4.7	78.2	76.8	71.3	65.7	60.2	54.6	49.0	73.1	5.1	73.1	71.6	66.0	60.5	54.9	49.4	43.8		
	72	91.3	4.8	56.3	49.7	43.2	36.6	30.0	-	-	87.1	5.3	54.5	47.9	41.4	34.8	28.2	-	-		
	67	87.9	4.8	71.4	64.9	58.3	51.7	45.1	38.6	32.0	82.2	5.3	69.1	62.5	56.0	49.4	42.8	36.2	29.7		
2600	62	82.2	4.7	82.2	79.1	73.3	66.7	60.1	53.5	47.0	76.4	5.2	76.4	74.2	69.4	62.8	56.3	49.7	43.1		
	57	80.4	4.7	80.4	79.7	76.5	70.0	63.4	56.8	50.3	75.2	5.2	75.2	74.5	71.3	64.8	58.2	51.6	45.0		
	72	93.8	4.8	61.3	53.7	46.1	38.5	30.9	-	-	89.6	5.4	59.6	52.0	44.4	36.9	29.3	-	-		
2925	67	90.2	4.8	77.4	69.9	62.3	54.7	47.1	39.5	31.9	84.5	5.3	75.3	67.7	60.1	52.5	44.9	37.4	29.8		
	62	84.4	4.8	84.4	84.4	78.3	70.7	63.1	55.5	47.9	78.6	5.2	78.6	78.6	74.6	67.0	59.4	51.8	44.2		
	57	82.6	4.7	82.6	82.6	81.8	74.2	66.6	59.1	51.5	77.4	5.2	77.4	77.4	76.6	69.0	61.5	53.9	46.3		
3250	72	94.5	4.8	65.3	56.6	48.0	39.4	30.7	-	-	90.5	5.4	63.7	55.1	46.5	37.8	29.2	-	-		
	67	90.9	4.8	83.2	73.5	64.8	56.2	47.6	38.9	30.3	85.4	5.3	80.1	71.5	62.8	54.2	45.6	36.9	28.3		
	62	85.0	4.8	85.0	85.0	82.0	73.3	64.7	56.0	47.4	79.4	5.2	79.4	79.4	77.4	68.8	60.1	51.5	42.9		
3250	57	83.1	4.7	83.1	83.1	82.8	74.1	65.5	56.9	48.2	78.2	5.2	78.2	78.2	77.8	69.2	60.5	51.9	43.3		
	72	95.1	4.9	69.3	59.6	49.9	40.2	30.5	-	-	91.4	5.4	67.8	58.2	48.5	38.8	29.1	-	-		
	67	91.5	4.8	88.9	77.1	67.4	57.7	48.0	38.3	28.6	86.3	5.3	84.9	75.2	65.6	55.9	46.2	36.5	26.8		
62	85.6	4.8	85.6	85.6	85.6	75.9	66.3	56.6	46.9	80.2	5.2	80.2	80.2	80.2	70.6	60.9	51.2	41.5			
57	83.7	4.7	83.7	83.7	83.7	74.0	64.4	54.7	45.0	79.0	5.2	79.0	79.0	79.0	69.3	59.6	49.9	40.2			
Temperature of Air on Condenser Coil 95°F											Temperature of Air on Condenser Coil 105°F										
1950	72	80.3	5.8	47.5	42.0	36.4	30.8	25.3	-	-	74.6	6.3	45.1	39.6	34.0	28.5	22.9	-	-		
	67	74.1	5.7	60.4	54.9	49.3	43.7	38.2	32.6	27.1	67.4	6.1	57.6	52.1	46.5	40.9	35.4	29.8	24.3		
	62	68.5	5.6	68.5	65.8	60.3	54.7	49.2	43.6	38.0	63.3	6.0	63.3	60.8	55.2	49.7	44.1	38.6	33.0		
2275	57	68.0	5.6	68.0	66.4	60.8	55.2	49.7	44.1	38.6	63.0	6.1	63.0	61.2	55.6	50.1	44.5	39.0	33.4		
	72	82.8	5.8	52.7	46.2	39.6	33.0	26.4	-	-	76.8	6.3	50.2	43.7	37.1	30.5	23.9	-	-		
	67	76.5	5.7	66.8	60.2	53.6	47.0	40.5	33.9	27.3	69.4	6.2	63.0	57.3	50.7	44.1	37.6	31.0	24.4		
2600	62	70.7	5.6	70.7	69.4	65.6	59.0	52.4	45.8	39.3	65.2	6.1	65.2	63.9	60.2	53.7	47.1	40.5	33.9		
	57	70.1	5.6	70.1	69.3	66.1	59.6	53.0	46.4	39.8	64.8	6.1	64.8	63.9	60.7	54.1	47.5	40.9	34.4		
	72	85.4	5.9	57.9	50.4	42.8	35.2	27.6	-	-	78.9	6.4	55.3	47.7	40.2	32.6	25.0	-	-		
2925	67	78.8	5.8	73.1	65.5	57.9	50.4	42.8	35.2	27.6	71.3	6.2	68.5	62.5	54.9	47.3	39.7	32.2	24.6		
	62	72.9	5.7	72.9	72.9	70.8	63.2	55.7	48.1	40.5	67.0	6.1	67.0	67.0	65.2	57.6	50.1	42.5	34.9		
	57	72.2	5.7	72.2	72.2	71.5	63.9	56.3	48.7	41.1	66.6	6.2	66.6	66.6	65.7	58.1	50.5	42.9	35.3		
3250	72	86.5	5.9	62.2	53.6	44.9	36.3	27.6	-	-	80.0	6.4	59.6	50.9	42.3	33.7	25.0	-	-		
	67	79.9	5.8	77.0	69.5	60.8	52.2	43.6	34.9	26.3	72.3	6.3	70.8	66.0	57.8	49.2	40.6	31.9	23.3		
	62	73.9	5.7	73.9	73.9	72.8	64.2	55.6	46.9	38.3	67.9	6.2	67.9	67.9	67.0	58.4	49.7	41.1	32.5		
3250	57	73.2	5.7	73.2	73.2	72.8	64.2	55.6	46.9	38.3	67.5	6.2	67.5	67.5	67.0	58.4	49.7	41.1	32.5		
	72	87.7	5.9	66.4	56.7	47.1	37.4	27.7	-	-	81.0	6.4	63.8	54.1	44.4	34.8	25.1	-	-		
	67	81.0	5.8	81.0	73.4	63.7	54.0	44.4	34.7	25.0	73.2	6.3	73.2	69.4	60.8	51.1	41.4	31.7	22.0		
62	74.9	5.7	74.9	74.9	74.9	65.2	55.5	45.8	36.1	68.8	6.2	68.8	68.8	68.8	59.1	49.4	39.7	30.0			
57	74.2	5.7	74.2	74.2	74.2	64.5	54.9	45.2	35.5	68.4	6.2	68.4	68.4	68.4	58.7	49.0	39.3	29.6			
Temperature of Air on Condenser Coil 115°F											Temperature of Air on Condenser Coil 125°F										
1950	72	69.0	6.8	42.8	37.2	31.6	26.1	20.5	-	-	63.3	7.3	40.4	34.8	29.2	23.7	18.1	-	-		
	67	60.7	6.6	54.8	49.3	43.7	38.2	32.6	27.0	21.5	54.0	7.1	52.0	46.5	40.9	35.4	29.8	24.2	18.7		
	62	58.2	6.5	58.2	55.8	50.2	44.7	39.1	33.5	28.0	53.0	7.0	53.0	50.7	45.2	39.6	34.1	28.5	23.0		
2275	57	58.0	6.6	58.0	56.0	50.5	44.9	39.3	33.8	28.2	53.0	7.1	53.0	50.9	45.3	39.7	34.2	28.6	23.1		
	72	70.7	6.8	47.7	41.2	34.6	28.0	21.4	-	-	64.6	7.4	45.2	38.7	32.1	25.5	18.9	-	-		
	67	62.3	6.7	59.3	54.4	47.8	41.2	34.7	28.1	21.5	55.2	7.1	55.2	51.5	44.9	38.3	31.8	25.2	18.6		
2600	62	59.6	6.6	59.6	58.5	54.9	48.3	41.8	35.2	28.6	54.1	7.1	54.1	53.0	49.6	43.0	36.4	29.9	23.3		
	57	59.4	6.7	59.4	58.5	55.2	48.6	42.0	35.5	28.9	54.1	7.2	54.1	53.1	49.7	43.1	36.6	30.0	23.4		
	72	72.5	6.9	52.7	45.1	37.5	30.0	22.4	-	-	66.0	7.4	50.1	42.5	34.9	27.3	19.8	-	-		
2925	67	63.8	6.7	63.8	59.5	51.9	44.3	36.7	29.1	21.6	56.3	7.2	56.3	56.3	48.9	41.3	33.7	26.1	18.5		
	62	61.1	6.6	61.1	61.1	59.6	52.0	44.4	36.9	29.3	55.3	7.1	55.3	55.3	54.0	46.4	38.8	31.2	23.7		
	57	60.9	6.7	60.9	60.9	59.9	52.3	44.7	37.2	29.6	55.3	7.2	55.3	55.3	54.1	46.5	39.0	31.4	23.8		
3250	72	73.4	6.9	57.0	48.3	39.7	31.0	22.4	-	-	66.8	7.5	54.3	45.7	37.1	28.4	19.8	-	-		
	67	64.6	6.7	64.6	62.5	54.8	46.2	37.6	28.9	20.3	57.0	7.2	57.0	57.0	51.8	43.2	34.6	25.9	17.3		
	62	61.9	6.7	61.9	61.9	61.2	52.5	43.9	35.2	26.6	55.9	7.1	55.9	55.9	55.3	46.7	38.0	29.4	20.8		
3250	57	61.7	6.7	61.7	61.7	61.2	52.6	43.9	35.3	26.7	55.9	7.3	55.9	55.9	55.4	46.7	38.1	29.5	20.8		
	72	74.3	7.0	61.2	51.5	41.8	32.1	22.4	-	-	67.6	7.5	58.6	48.9	39.2	29.5	19.8	-	-		
	67	65.5	6.8	65.5	65.5	57.8	48.1	38.4	28.7	19.0	57.7	7.3	57.7	57.7	54.8	45.1	35.5	25.8	16.1		
62	62.7	6.7	62.7	62.7	62.7	53.0	43.3	33.6	23.9	56.6	7.2	56.6	56.6	56.6	46.9	37.2	27.6	17.9			
57	62.5	6.8	62.5	62.5	62.5	52.8	43.1	33.4	23.7	56.6	7.3	56.6	56.6	56.6	46.9	37.2	27.6	17.9			

1 These capacities are gross ratings. For net capacity, deduct air blower motor, MBh = 3.415 x kW. Refer to the appropriate Blower Performance Table for the kW of the supply air blower motor.
 2 These ratings include the condensate fan motors (total 1 kW) and the compressor motors but not the supply air blower motor.

TABLE 6: COOLING CAPACITY DH090 (7-1/2 TON) UNIT

Air On Evap. Coil		Temperature of Air on Condenser Coil 75°F										Temperature of Air on Condenser Coil 85°F									
CFM	WB (°F)	Tot. Cap. ¹ (MBH)	Tot. Input ² (kW)	Sensible Capacity (MBH) [*] Return Dry Bulb (°F)								Tot. Cap. ¹ (MBH)	Tot. Input ² (kW)	Sensible Capacity (MBH) [*] Return Dry Bulb (°F)							
				86	83	80	77	74	71	68	86			83	80	77	74	71	68		
2250	72	102.7	5.7	60.1	53.7	47.3	40.9	34.5	-	-	98.5	6.2	58.2	51.8	45.4	39.0	32.5	-	-		
	67	98.7	5.6	75.6	69.2	62.8	56.4	50.0	43.5	37.1	93.0	6.1	73.4	67.0	60.5	54.1	47.7	41.3	34.9		
	62	95.0	5.6	95.0	87.3	80.9	74.5	68.0	61.6	55.2	88.7	6.1	88.7	82.4	76.0	69.6	63.2	56.8	50.4		
	57	96.7	5.5	96.7	90.6	84.1	77.7	71.3	64.9	58.5	88.4	6.0	88.4	84.3	77.9	71.5	65.0	58.6	52.2		
2625	72	105.1	5.7	65.5	57.9	50.3	42.8	35.2	-	-	100.9	6.2	63.8	56.2	48.6	41.1	33.5	-	-		
	67	101.0	5.6	82.0	74.4	66.8	59.2	51.6	44.0	36.5	95.2	6.1	80.1	72.5	64.9	57.3	49.7	42.2	34.6		
	62	97.2	5.6	97.2	93.4	86.1	78.5	70.9	63.3	55.7	90.8	6.1	90.8	87.7	81.5	73.9	66.3	58.8	51.2		
	57	98.9	5.5	98.9	95.9	89.6	82.0	74.4	66.8	59.2	90.5	6.1	90.5	88.5	83.5	75.9	68.3	60.7	53.2		
3000	72	107.5	5.7	70.9	62.1	53.4	44.6	35.9	-	-	103.2	6.3	69.4	60.7	51.9	43.2	34.4	-	-		
	67	103.3	5.6	88.3	79.5	70.8	62.0	53.3	44.5	35.8	97.4	6.2	86.8	78.0	69.3	60.5	51.8	43.0	34.3		
	62	99.4	5.6	99.4	99.4	91.2	82.5	73.8	65.0	56.3	92.9	6.1	92.9	92.9	87.0	78.2	69.5	60.7	52.0		
	57	101.2	5.5	101.2	101.2	95.0	86.2	77.5	68.7	60.0	92.6	6.1	92.6	92.6	89.1	80.3	71.6	62.8	54.1		
3375	72	108.5	5.7	75.3	65.4	55.4	45.4	35.5	-	-	104.6	6.3	74.2	64.3	54.3	44.3	34.4	-	-		
	67	104.3	5.6	94.8	83.4	73.5	63.5	53.6	43.6	33.6	98.7	6.2	92.4	82.4	72.5	62.5	52.5	42.6	32.6		
	62	100.4	5.6	100.4	100.4	95.9	85.9	76.0	66.0	56.0	94.2	6.1	94.2	94.2	91.0	81.0	71.0	61.1	51.1		
	57	102.2	5.5	102.2	102.2	99.1	89.2	79.2	69.2	59.3	93.9	6.1	93.9	93.9	92.1	82.1	72.2	62.2	52.3		
3750	72	109.6	5.7	79.8	68.6	57.4	46.2	35.1	-	-	106.0	6.3	79.0	67.9	56.7	45.5	34.3	-	-		
	67	105.4	5.6	101.3	87.3	76.2	65.0	53.8	42.6	31.5	100.1	6.2	98.0	86.8	75.6	64.5	53.3	42.1	30.9		
	62	101.4	5.6	101.4	101.4	100.5	89.4	78.2	67.0	55.8	95.4	6.1	95.4	95.4	95.0	83.8	72.6	61.4	50.3		
	57	103.3	5.5	103.3	103.3	92.1	80.9	69.7	58.6	47.5	95.1	6.1	95.1	95.1	95.1	83.9	72.8	61.6	50.4		
Temperature of Air on Condenser Coil 95°F										Temperature of Air on Condenser Coil 105°F											
2250	72	94.3	6.7	56.3	49.8	43.4	37.0	30.6	-	-	87.5	7.3	53.7	47.2	40.8	34.4	28.0	-	-		
	67	87.3	6.7	71.1	64.7	58.3	51.9	45.5	39.1	32.7	79.7	7.2	67.8	61.4	55.0	48.6	42.2	35.8	29.4		
	62	82.4	6.5	82.4	77.6	71.2	64.8	58.4	51.9	45.5	76.0	7.1	76.0	71.7	65.3	58.9	52.4	46.0	39.6		
	57	80.1	6.5	80.1	78.0	71.6	65.2	58.8	52.4	46.0	74.0	7.1	74.0	72.0	65.6	59.2	52.7	46.3	39.9		
2625	72	96.6	6.8	62.1	54.5	46.9	39.4	31.8	-	-	89.8	7.4	59.6	52.0	44.4	36.8	29.3	-	-		
	67	89.4	6.7	78.2	70.6	63.0	55.4	47.9	40.3	32.7	81.8	7.2	74.3	67.4	59.9	52.3	44.7	37.1	29.5		
	62	84.4	6.6	84.4	82.0	76.9	69.4	61.8	54.2	46.6	78.0	7.1	78.0	75.8	71.0	63.4	55.8	48.3	40.7		
	57	82.1	6.6	82.1	81.0	77.4	69.8	62.2	54.7	47.1	75.9	7.1	75.9	74.9	71.3	63.8	56.2	48.6	41.0		
3000	72	98.9	6.8	67.9	59.2	50.5	41.7	33.0	-	-	92.1	7.4	65.5	56.8	48.0	39.3	30.5	-	-		
	67	91.5	6.7	85.2	76.5	67.7	59.0	50.2	41.5	32.8	83.8	7.3	80.7	73.5	64.7	56.0	47.2	38.5	29.7		
	62	86.4	6.6	86.4	86.4	82.7	73.9	65.2	56.4	47.7	80.0	7.2	80.0	80.0	76.7	68.0	59.2	50.5	41.7		
	57	84.0	6.6	84.0	84.0	83.2	74.4	65.7	57.0	48.2	77.8	7.2	77.8	77.8	77.1	68.3	59.6	50.8	42.1		
3375	72	100.6	6.9	73.1	63.2	53.2	43.2	33.3	-	-	93.4	7.4	70.8	60.8	50.8	40.9	30.9	-	-		
	67	93.1	6.8	90.0	81.4	71.4	61.5	51.5	41.5	31.6	85.1	7.3	83.5	77.8	68.5	58.6	48.6	38.6	28.7		
	62	87.9	6.7	87.9	87.9	86.1	76.1	66.1	56.2	46.2	81.2	7.2	81.2	81.2	79.6	69.6	59.6	49.7	39.7		
	57	85.5	6.6	85.5	85.5	85.1	75.1	65.2	55.2	45.2	79.0	7.2	79.0	79.0	78.6	68.7	58.7	48.7	38.8		
3750	72	102.4	6.9	78.3	67.1	55.9	44.8	33.6	-	-	94.8	7.5	76.0	64.9	53.7	42.5	31.3	-	-		
	67	94.7	6.8	94.7	86.3	75.1	63.9	52.8	41.6	30.4	86.4	7.3	86.4	82.2	72.4	61.2	50.0	38.8	27.6		
	62	89.4	6.7	89.4	89.4	89.4	78.2	67.1	55.9	44.7	82.4	7.2	82.4	82.4	82.4	71.2	60.0	48.9	37.7		
	57	87.0	6.7	87.0	87.0	87.0	75.8	64.6	53.4	42.2	80.2	7.2	80.2	80.2	80.2	69.0	57.8	46.6	35.5		
Temperature of Air on Condenser Coil 115°F										Temperature of Air on Condenser Coil 125°F											
2250	72	80.6	7.9	51.1	44.6	38.2	31.8	25.4	-	-	73.7	8.4	48.4	42.0	35.6	29.2	22.8	-	-		
	67	72.0	7.7	64.6	58.1	51.7	45.3	38.9	32.5	26.1	64.4	8.2	61.3	54.8	48.4	42.0	35.6	29.2	22.8		
	62	69.6	7.6	69.6	65.8	59.4	52.9	46.5	40.1	33.7	63.2	8.1	63.2	59.9	53.5	47.0	40.6	34.2	27.8		
	57	67.8	7.6	67.8	66.0	59.5	53.1	46.7	40.3	33.9	61.6	8.2	61.6	59.9	53.5	47.1	40.7	34.3	27.8		
2625	72	82.9	7.9	57.1	49.5	41.9	34.3	26.7	-	-	76.0	8.5	54.5	47.0	39.4	31.8	24.2	-	-		
	67	74.1	7.7	70.3	64.3	56.7	49.1	41.5	34.0	26.4	66.4	8.2	66.4	61.1	53.5	46.0	38.4	30.8	23.2		
	62	71.6	7.7	71.6	69.7	65.1	57.5	49.9	42.3	34.7	65.2	8.2	65.2	63.5	59.1	51.6	44.0	36.4	28.8		
	57	69.7	7.7	69.7	68.8	65.3	57.7	50.1	42.5	34.9	63.5	8.2	63.5	62.7	59.2	51.6	44.0	36.4	28.9		
3000	72	85.2	8.0	63.1	54.3	45.6	36.8	28.1	-	-	78.3	8.5	60.6	51.9	43.1	34.4	25.6	-	-		
	67	76.1	7.8	76.1	70.4	61.7	52.9	44.2	35.4	26.7	68.4	8.3	68.4	67.4	58.6	49.9	41.1	32.4	23.6		
	62	73.6	7.7	73.6	73.6	70.8	62.0	53.3	44.5	35.8	67.2	8.2	67.2	67.2	64.8	56.1	47.3	38.6	29.8		
	57	71.6	7.7	71.6	71.6	71.0	62.2	53.5	44.7	36.0	65.4	8.3	65.4	65.4	64.9	56.1	47.4	38.6	29.9		
3375	72	86.2	8.0	68.4	58.5	48.5	38.5	28.6	-	-	79.0	8.6	66.1	56.1	46.1	36.2	26.2	-	-		
	67	77.1	7.8	77.1	74.2	65.6	55.7	45.7	35.7	25.8	69.0	8.4	69.0	69.0	62.7	52.8	42.8	32.8	22.9		
	62	74.5	7.7	74.5	74.5	73.1	63.1	53.2	43.2	33.2	67.8	8.3	67.8	67.8	66.6	56.6	46.7	36.7	26.8		
	57	72.5	7.8	72.5	72.5	72.2	62.2	52.3	42.3	32.3	66.0	8.3	66.0	66.0	65.8	55.8	45.8	35.9	25.9		
3750	72	87.3	8.1	73.8	62.6	51.4	40.2	29.1	-	-	79.7	8.7	71.5	60.3	49.2	38.0	26.8	-	-		
	67	78.0	7.9	78.0	78.0	69.6	58.4	47.2	36.1	24.9	69.7	8.4	69.7	69.7	66.8	55.6	44.5	33.3	22.1		
	62	75.4	7.8	75.4	75.4	75.4	64.2	53.0	41.9	30.7	68.4	8.3	68.4	68.4	68.4	57.2	46.0	34.8	23.7		
	57	73.4	7.8	73.4	73.4	73.4	62.2	51.0	39.9	28.7	66.6	8.4	66.6	66.6	66.6	55.4	44.3	33.1	21.9		

1 These capacities are gross ratings. For net capacity, deduct air blower motor, MBh = 3.415 x kW. Refer to the appropriate Blower Performance Table for the kW of the supply air blower motor.
 2 These ratings include the condensate fan motors (total 1 kW) and the compressor motors but not the supply air blower motor.

TABLE 7: COOLING CAPACITY DH102 (8-1/2 TON) UNIT

Air On Evap. Coil		Temperature of Air on Condenser Coil 75°F									Temperature of Air on Condenser Coil 85°F										
CFM	WB (°F)	Tot. Cap. ¹ (MBH)	Tot. Input ² (kW)	Sensible Capacity (MBH) [*] Return Dry Bulb (°F)								Tot. Cap. ¹ (MBH)	Tot. Input ² (kW)	Sensible Capacity (MBH) [*] Return Dry Bulb (°F)							
				86	83	80	77	74	71	68	86			83	80	77	74	71	68		
2550	72	117.0	1.8	66.8	59.5	52.2	44.9	37.7	-	-	112.5	7.6	64.3	57.0	49.8	42.5	35.2	-	-		
	67	112.1	1.9	85.1	77.8	70.5	63.2	56.0	48.7	41.4	106.1	7.5	82.2	74.9	67.7	60.4	53.1	45.8	38.6		
	62	104.1	2.0	104.	99.2	92.0	84.7	77.4	70.2	62.9	98.1	7.4	98.1	93.4	86.1	78.8	71.6	64.3	57.0		
2975	57	104.5	1.9	104.	103.	96.0	88.7	81.5	74.2	66.9	97.5	7.4	97.5	96.7	89.4	82.2	74.9	67.6	60.4		
	72	120.7	4.3	72.7	64.1	55.5	46.9	38.3	-	-	116.0	7.6	70.5	61.9	53.3	44.7	36.1	-	-		
	67	115.7	4.3	92.1	83.5	75.0	66.4	57.8	49.2	40.6	109.4	7.5	89.6	81.0	72.4	63.9	55.3	46.7	38.1		
3400	62	107.5	4.4	107.	105.	97.8	89.2	80.6	72.0	63.4	101.1	7.4	101.	98.8	92.2	83.6	75.0	66.4	57.8		
	57	107.8	4.4	107.	107.	102.	93.5	84.9	76.3	67.7	100.6	7.4	100.	100.	95.8	87.2	78.6	70.0	61.4		
	72	124.5	6.8	78.6	68.7	58.8	48.9	39.0	-	-	119.6	7.6	76.6	66.7	56.8	46.9	37.0	-	-		
3825	67	119.3	6.8	99.2	89.3	79.4	69.5	59.6	49.6	39.7	112.7	7.5	97.1	87.1	77.2	67.3	57.4	47.5	37.6		
	62	110.8	6.9	110.	110.	103.	93.7	83.8	73.9	63.9	104.2	7.4	104.	104.	98.3	88.4	78.5	68.6	58.6		
	57	111.2	6.8	111.	111.	108.	98.3	88.3	78.4	68.5	103.7	7.4	103.	103.	102.	92.2	82.3	72.4	62.4		
4250	72	125.4	6.9	83.4	72.2	60.9	49.6	38.3	-	-	120.8	7.7	81.8	70.5	59.2	47.9	36.6	-	-		
	67	120.2	6.9	104.	93.5	82.2	70.9	59.6	48.3	37.0	113.9	7.6	103.	91.8	80.5	69.2	57.9	46.6	35.4		
	62	111.6	6.9	111.	111.	108.	96.7	85.4	74.1	62.8	105.3	7.5	105.	105.	102.	91.1	79.8	68.5	57.2		
2550	57	112.0	6.9	112.	112.	110.	99.2	87.9	76.6	65.3	104.7	7.5	104.	104.	104.	92.7	81.4	70.1	58.8		
	72	126.3	6.9	88.3	75.6	62.9	50.3	37.6	-	-	122.1	7.7	87.0	74.3	61.6	49.0	36.3	-	-		
	67	121.0	6.9	110.	97.6	85.0	72.3	59.6	46.9	34.3	115.1	7.6	109.	96.5	83.8	71.1	58.5	45.8	33.1		
2975	62	112.4	7.0	112.	112.	112.	99.8	87.1	74.4	61.8	106.4	7.5	106.	106.	106.	93.8	81.1	68.4	55.8		
	57	112.8	6.9	112.	112.	112.	100.	87.5	74.8	62.2	105.8	7.5	105.	105.	105.	93.2	80.5	67.8	55.2		
	Temperature of Air on Condenser Coil 95°F									Temperature of Air on Condenser Coil 105°F											
2550	72	108.0	13.4	61.8	54.6	47.3	40.0	32.8	-	-	99.4	11.5	59.2	52.0	44.7	37.4	30.2	-	-		
	67	100.0	13.1	79.3	72.1	64.8	57.5	50.3	43.0	35.7	90.8	11.2	75.4	68.1	60.8	53.6	46.3	39.0	31.7		
	62	92.0	12.8	92.0	87.5	80.3	73.0	65.7	58.5	51.2	82.0	11.0	82.0	79.8	72.7	65.4	58.2	50.9	43.6		
2975	57	90.5	12.9	90.5	90.2	82.9	75.6	68.3	61.1	53.8	83.3	11.1	83.3	82.3	75.1	67.8	60.5	53.2	46.0		
	72	111.3	10.9	68.2	59.7	51.1	42.5	33.9	-	-	102.8	10.3	65.7	57.2	48.6	40.0	31.4	-	-		
	67	103.1	10.7	87.1	78.5	69.9	61.4	52.8	44.2	35.6	93.9	10.0	83.3	74.7	66.1	57.5	48.9	40.3	31.7		
3400	62	94.8	10.4	94.8	92.6	86.6	78.0	69.4	60.9	52.3	84.8	9.8	84.8	83.7	79.0	70.4	61.8	53.2	44.6		
	57	93.3	10.5	93.3	93.1	89.5	80.9	72.3	63.7	55.1	86.2	9.9	86.2	85.7	81.5	72.9	64.3	55.7	47.1		
	72	114.7	8.4	74.6	64.7	54.8	44.9	35.0	-	-	106.2	9.1	72.3	62.3	52.4	42.5	32.6	-	-		
3825	67	106.2	8.2	94.9	85.0	75.1	65.2	55.3	45.3	35.4	97.0	8.9	91.2	81.2	71.3	61.4	51.5	41.6	31.7		
	62	97.7	8.0	97.7	97.7	93.0	83.1	73.2	63.3	53.3	87.6	8.7	87.6	87.6	85.2	75.3	65.4	55.5	45.6		
	57	96.1	8.1	96.1	96.1	96.0	86.1	76.2	66.3	56.4	89.1	8.7	89.1	89.1	88.0	78.1	68.1	58.2	48.3		
4250	72	116.3	8.4	80.2	68.9	57.6	46.3	35.0	-	-	107.6	9.1	78.0	66.7	55.4	44.1	32.9	-	-		
	67	107.7	8.3	101.	90.2	78.9	67.6	56.3	45.0	33.7	98.2	8.9	95.0	86.7	75.4	64.1	52.8	41.6	30.3		
	62	99.1	8.1	99.1	99.1	96.7	85.4	74.1	62.8	51.6	88.8	8.7	88.8	88.8	87.6	76.3	65.0	53.7	42.4		
2550	57	97.5	8.1	97.5	97.5	97.4	86.2	74.9	63.6	52.3	90.2	8.8	90.2	90.2	89.7	78.4	67.1	55.8	44.5		
	72	117.9	8.4	85.7	73.0	60.3	47.7	35.0	-	-	108.9	9.2	83.8	71.1	58.5	45.8	33.1	-	-		
	67	109.2	8.3	108.	95.3	82.7	70.0	57.3	44.7	32.0	99.5	8.9	98.9	92.2	79.5	66.9	54.2	41.5	28.9		
2975	62	100.5	8.1	100.	100.	100.	87.8	75.1	62.4	49.8	89.9	8.8	89.9	89.9	89.9	77.2	64.6	51.9	39.2		
	57	98.9	8.1	98.9	98.9	98.9	86.2	73.5	60.8	48.2	91.3	8.8	91.3	91.3	91.3	78.7	66.0	53.3	40.7		
	Temperature of Air on Condenser Coil 115°F									Temperature of Air on Condenser Coil 125°F											
2550	72	90.8	9.6	56.6	49.4	42.1	34.8	27.5	-	-	82.2	7.8	54.0	46.8	39.5	32.2	24.9	-	-		
	67	81.6	9.4	71.4	64.1	56.8	49.6	42.3	35.0	27.8	72.3	7.5	67.4	60.1	52.9	45.6	38.3	31.0	23.8		
	62	72.1	9.2	72.1	72.1	65.1	57.9	50.6	43.3	36.0	62.1	7.3	62.1	62.1	57.6	50.3	43.0	35.7	28.5		
2975	57	76.2	9.3	76.2	74.5	67.2	59.9	52.7	45.4	38.1	69.0	7.5	69.0	66.7	59.4	52.1	44.8	37.6	30.3		
	72	94.3	9.7	63.3	54.7	46.1	37.5	28.9	-	-	85.8	9.1	60.8	52.2	43.6	35.0	26.4	-	-		
	67	84.7	9.4	79.4	70.8	62.2	53.6	45.0	36.4	27.8	75.4	8.8	75.4	66.9	58.3	49.8	41.2	32.6	24.0		
3400	62	74.8	9.2	74.8	74.8	71.3	62.7	54.1	45.5	36.9	64.8	8.6	64.8	64.8	63.6	55.0	46.4	37.8	29.2		
	57	79.1	9.3	79.1	78.2	73.6	65.0	56.4	47.8	39.2	71.9	8.8	71.9	70.8	65.6	57.0	48.4	39.8	31.3		
	72	97.7	9.8	69.9	60.0	50.0	40.1	30.2	-	-	89.3	10.5	67.5	57.6	47.7	37.7	27.8	-	-		
3825	67	87.8	9.5	87.4	77.5	67.6	57.7	47.8	37.8	27.9	78.6	10.1	78.6	73.7	63.8	53.9	44.0	34.1	24.2		
	62	77.6	9.3	77.6	77.6	77.4	67.5	57.6	47.7	37.8	67.5	9.9	67.5	67.5	67.5	59.7	49.8	39.9	30.0		
	57	82.0	9.4	82.0	82.0	79.9	70.0	60.1	50.2	40.3	74.9	10.1	74.9	74.9	71.9	62.0	52.0	42.1	32.2		
4250	72	98.8	9.8	75.9	64.6	53.3	42.0	30.7	-	-	90.1	10.6	73.7	62.5	51.2	39.9	28.6	-	-		
	67	88.8	9.5	88.6	83.3	72.0	60.7	49.4	38.1	26.8	79.3	10.2	79.3	79.3	68.5	57.2	46.0	34.7	23.4		
	62	78.5	9.4	78.5	78.5	78.4	67.1	55.8	44.5	33.2	68.2	10.0	68.2	68.2	68.2	57.9	46.6	35.3	24.1		
2550	57	82.9	9.5	82.9	82.9	81.9	70.6	59.3	48.0	36.7	75.6	10.1	75.6	75.6	74.1	62.8	51.5	40.2	28.9		
	72	100.0	9.9	81.9	69.2	56.6	43.9	31.2	-	-	91.0	10.6	80.0	67.3	54.7	42.0	29.3	-	-		
	67	89.8	9.6	89.8	89.1	76.4	63.7	51.0	38.4	25.7	80.0	10.3	80.0	80.0	73.2	60.6	47.9	35.2	22.6		
2975	62	79.3	9.4	79.3	79.3	79.3	66.7	54.0	41.3	28.7	68.8	10.1	68.8	68.8	68.8	56.1	43.5	30.8	18.1		
	57	83.8	9.5	83.8	83.8	83.8	71.2	58.5	45.8	33.2	76.3	10.2	76.3	76.3	76.3	63.7	51.0	38.3	25.6		

1 These capacities are gross ratings. For net capacity, deduct air blower motor, MBh = 3.415 x kW. Refer to the appropriate Blower Performance Table for the kW of the supply air blower motor.
 2 These ratings include the condensate fan motors (total 1 kW) and the compressor motors but not the supply air blower motor.

TABLE 8: COOLING CAPACITY DH120 (10 TON) UNIT

Air On Evap. Coil		Temperature of Air on Condenser Coil 85°F									Temperature of Air on Condenser Coil 95°F										
CFM	WB (°F)	Tot. Cap.* (MBH)	Tot. Input† (kW)	Sensible Capacity (MBH)* Return Dry Bulb (°F)								Tot. Cap.* (MBH)	Tot. Input† (kW)	Sensible Capacity (MBH)* Return Dry Bulb (°F)							
				86	83	80	77	74	71	68	86			83	80	77	74	71	68		
3000	72	136	8.8	79	71	62	53	45	-	-	126	9.4	79	70	61	53	44	-	-		
	67	122	8.6	99	90	82	73	64	56	47	114	9.1	96	88	79	70	62	53	45		
	62	110	8.3	110	107	98	89	81	72	64	108	9.0	108	106	97	89	80	72	63		
	57	109	8.7	109	105	97	88	80	71	63	103	9.1	103	102	93	84	76	67	59		
3500	72	140	8.9	88	78	68	58	48	-	-	130	9.5	87	77	67	57	47	-	-		
	67	126	8.7	110	100	89	79	69	59	49	118	9.1	106	96	86	76	66	56	46		
	62	114	8.4	114	112	107	97	87	77	67	112	9.0	112	111	106	96	86	76	65		
	57	112	8.7	112	110	106	96	86	76	66	106	9.1	106	106	101	91	81	71	61		
4000	72	144	9.0	97	86	74	62	51	-	-	134	9.5	96	84	72	61	49	-	-		
	67	129	8.8	121	109	97	86	74	62	51	122	9.2	116	105	93	81	70	58	46		
	62	117	8.5	117	117	117	105	93	82	70	115	9.1	115	115	115	103	91	80	68		
	57	115	8.8	115	115	115	104	92	80	69	110	9.2	110	110	110	98	86	75	63		
4500	72	151	9.1	106	93	80	66	53	-	-	139	9.6	105	92	78	65	52	-	-		
	67	135	8.9	131	118	105	91	78	65	52	126	9.3	124	114	101	87	74	61	48		
	62	122	8.6	122	122	122	109	96	82	69	120	9.2	120	120	119	106	93	79	66		
	57	121	8.9	121	121	121	107	94	81	67	114	9.3	114	114	114	100	87	74	61		
5000	72	157	9.2	115	100	85	70	55	-	-	144	9.7	114	99	84	69	54	-	-		
	67	141	9.0	141	127	112	97	82	67	53	131	9.4	131	123	108	93	78	63	49		
	62	128	8.7	128	128	128	113	98	83	68	124	9.3	124	124	124	109	94	79	64		
	57	126	9.1	126	126	126	111	96	81	66	118	9.4	118	118	118	103	88	73	58		
		Temperature of Air on Condenser Coil 105°F									Temperature of Air on Condenser Coil 115°F										
3000	72	116	9.9	74	66	57	49	40	-	-	106	10.4	70	61	53	44	36	-	-		
	67	106	9.6	92	84	75	67	58	50	41	97	10.1	89	80	72	63	55	46	37		
	62	98	9.4	98	97	88	80	71	63	54	88	9.7	88	88	80	71	63	54	46		
	57	96	9.5	96	95	87	78	69	61	52	88	10.0	88	88	80	72	63	54	46		
3500	72	120	10.0	82	72	62	52	42	-	-	110	10.5	78	68	58	47	37	-	-		
	67	109	9.7	101	92	82	72	62	52	42	100	10.2	96	88	78	68	58	48	38		
	62	101	9.4	101	101	96	86	76	66	56	91	9.8	91	91	87	77	67	57	47		
	57	99	9.6	99	99	94	84	74	64	54	91	10.1	91	91	87	77	67	57	47		
4000	72	124	10.1	91	79	67	56	44	-	-	114	10.6	86	74	62	51	39	-	-		
	67	113	9.7	110	100	89	77	65	54	42	104	10.3	104	96	84	73	61	49	38		
	62	105	9.5	105	105	104	93	81	69	58	94	9.9	94	94	94	82	71	59	47		
	57	102	9.7	102	102	102	90	79	67	55	94	10.2	94	94	94	83	71	59	48		
4500	72	126	10.1	99	86	73	60	46	-	-	114	10.6	94	81	68	54	41	-	-		
	67	115	9.8	114	107	96	83	70	56	43	104	10.3	104	100	92	78	65	52	39		
	62	107	9.6	107	107	107	93	80	67	54	94	10.0	94	94	94	81	68	54	41		
	57	104	9.8	104	104	104	91	78	64	51	95	10.3	95	95	95	81	68	55	42		
5000	72	129	10.2	108	93	79	64	49	-	-	114	10.7	103	88	73	58	43	-	-		
	67	117	9.9	117	114	104	89	74	59	44	104	10.4	104	104	99	84	69	54	39		
	62	109	9.7	109	109	109	94	79	64	50	94	10.0	94	94	94	80	65	50	35		
	57	106	9.8	106	106	106	91	77	62	47	95	10.3	95	95	95	80	65	50	35		
		Temperature of Air on Condenser Coil 125°F																			
3000	72	97	10.8	66	57	48	40	31	-	-											
	67	88	10.5	85	77	68	59	51	42	34											
	62	78	10.1	78	78	71	63	54	45	37											
	57	81	10.4	81	81	74	65	57	48	39											
3500	72	100	11.0	73	63	53	43	33	-	-											
	67	92	10.7	91	84	74	64	54	44	34											
	62	81	10.2	81	81	77	67	57	47	37											
	57	84	10.6	84	84	80	70	60	50	40											
4000	72	104	11.1	80	69	57	46	34	-	-											
	67	95	10.8	95	92	80	68	57	45	33											
	62	83	10.3	83	83	83	72	61	49	37											
	57	87	10.7	87	87	87	75	63	52	40											
4500	72	101	11.1	89	76	62	49	36	-	-											
	67	93	10.9	93	93	87	74	61	47	34											
	62	82	10.4	82	82	82	69	55	42	29											
	57	85	10.8	85	85	85	72	59	45	32											
5000	72	99	11.2	97	82	67	52	38	-	-											
	67	91	10.9	91	91	91	79	65	50	35											
	62	80	10.4	80	80	80	65	50	35	20											
	57	83	10.8	83	83	83	68	54	39	24											

* These capacities are gross ratings. For net capacity, deduct air blower motor, MBH = 3.415 x kW. Refer to the appropriate Blower Performance Table for the kW of the supply air blower motor.

† These ratings include condenser fan motors and the compressor motors but not the supply air blower motor.

TABLE 9: COOLING CAPACITY DH150 (12-1/2 TON) UNIT

Air On Evap. Coil		Temperature of Air on Condenser Coil 85°F										Temperature of Air on Condenser Coil 95°F									
CFM	WB (°F)	Tot. Cap.* (MBH)	Tot. Input† (kW)	Sensible Capacity (MBH)* Return Dry Bulb (°F)								Tot. Cap.* (MBH)	Tot. Input† (kW)	Sensible Capacity (MBH)* Return Dry Bulb (°F)							
				86	83	80	77	74	71	68	86			83	80	77	74	71	68		
3750	72	165	11.9	95	85	74	63	52	-	-	159	13.1	94	83	72	62	51	-	-		
	67	158	11.8	124	114	103	92	82	71	60	151	13.0	121	111	100	89	79	68	57		
	62	148	11.6	147	137	126	115	105	94	83	141	12.8	141	135	124	113	103	92	81		
4375	57	138	11.5	138	135	124	113	103	92	81	132	12.8	132	130	120	109	98	87	77		
	72	169	11.9	105	92	80	67	54	-	-	163	13.2	103	91	78	65	53	-	-		
	67	161	11.8	136	124	111	98	86	73	61	155	13.1	133	121	108	95	83	70	57		
5000	62	151	11.7	151	146	136	123	111	98	85	144	12.9	144	141	134	121	109	96	83		
	57	141	11.5	141	139	134	121	109	96	83	135	12.8	135	134	129	116	104	91	78		
	72	172	12.0	115	100	86	71	56	-	-	167	13.2	113	98	84	69	55	-	-		
5625	67	165	11.9	148	134	119	105	90	76	61	159	13.1	145	131	116	101	87	72	58		
	62	155	11.7	155	155	146	132	117	102	88	148	12.9	148	148	144	129	115	100	85		
	57	144	11.6	144	144	144	129	115	100	86	139	12.9	139	139	139	124	109	95	80		
6250	72	172	11.9	121	105	88	71	55	-	-	166	13.2	120	104	87	70	54	-	-		
	67	164	11.8	156	139	122	106	89	73	56	158	13.1	151	137	120	104	87	71	54		
	62	154	11.7	154	154	150	133	117	100	83	147	12.9	147	147	145	128	112	95	78		
6250	57	143	11.5	143	143	143	127	110	94	77	138	12.8	138	138	138	121	104	88	71		
	72	171	11.9	127	109	90	72	53	-	-	165	13.2	127	109	90	71	53	-	-		
	67	164	11.8	163	144	126	107	88	70	51	157	13.1	157	143	125	106	88	69	50		
62	154	11.6	154	154	154	135	116	98	79	146	12.9	146	146	146	127	108	90	71			
57	143	11.5	143	143	143	124	106	87	68	137	12.8	137	137	137	118	99	81	62			
		Temperature of Air on Condenser Coil 105°F										Temperature of Air on Condenser Coil 115°F									
3750	72	152	14.6	91	80	70	59	48	-	-	145	16.2	88	78	67	56	46	-	-		
	67	143	14.5	118	107	97	86	75	64	54	135	15.9	114	104	93	82	72	61	50		
	62	133	14.3	133	128	118	107	96	86	75	125	15.8	125	122	111	101	90	79	68		
4375	57	124	14.2	124	122	111	100	90	79	68	116	15.7	116	113	103	92	81	71	60		
	72	156	14.7	101	88	76	63	50	-	-	149	16.2	99	86	73	61	48	-	-		
	67	147	14.5	130	118	105	92	80	67	54	138	15.9	127	114	102	89	77	64	51		
5000	62	137	14.3	137	134	128	115	103	90	77	129	15.8	129	127	122	109	96	84	71		
	57	127	14.3	127	126	121	108	95	83	70	119	15.7	119	118	112	100	87	75	62		
	72	160	14.7	111	96	82	67	53	-	-	153	16.2	109	94	80	65	50	-	-		
5625	67	150	14.5	142	128	113	99	84	70	55	142	15.9	140	125	111	96	81	67	52		
	62	140	14.4	140	140	138	123	109	94	80	132	15.8	132	132	132	118	103	88	74		
	57	130	14.3	130	130	130	116	101	87	72	122	15.8	122	122	122	108	93	78	64		
6250	72	159	14.7	118	102	85	68	52	-	-	152	16.2	116	100	83	66	50	-	-		
	67	149	14.5	145	134	118	101	85	68	51	141	15.9	140	132	115	99	82	66	49		
	62	139	14.4	139	139	138	121	105	88	72	131	15.8	131	131	131	115	98	81	65		
6250	57	129	14.3	129	129	129	113	96	80	63	121	15.8	121	121	121	105	88	71	55		
	72	158	14.7	126	107	88	70	51	-	-	151	16.2	124	105	87	68	49	-	-		
	67	148	14.5	148	141	122	104	85	67	48	140	15.9	140	139	120	102	83	64	46		
62	138	14.3	138	138	138	119	101	82	63	130	15.8	130	130	130	112	93	74	56			
57	128	14.3	128	128	128	110	91	72	54	120	15.8	120	120	120	102	83	64	46			
		Temperature of Air on Condenser Coil 125°F																			
3750	72	138	17.7	86	75	64	54	43	-	-											
	67	126	17.3	111	100	90	79	68	58	47											
	62	118	17.2	118	116	105	94	83	73	62											
4375	57	108	17.2	108	105	94	84	73	62	52											
	72	142	17.7	96	84	71	58	46	-	-											
	67	130	17.3	124	111	99	86	73	61	48											
5000	62	121	17.2	121	120	116	103	90	78	65											
	57	111	17.2	111	109	104	91	79	66	54											
	72	146	17.7	107	92	78	63	48	-	-											
5625	67	133	17.4	133	122	108	93	79	64	50											
	62	124	17.2	124	124	124	112	97	83	68											
	57	114	17.2	114	114	114	99	85	70	56											
6250	72	145	17.7	114	98	81	65	48	-	-											
	67	132	17.4	132	130	113	96	80	63	46											
	62	123	17.3	123	123	123	108	91	75	58											
6250	57	113	17.2	113	113	113	96	80	63	47											
	72	144	17.7	122	103	85	66	47	-	-											
	67	131	17.4	131	131	118	99	81	62	43											
62	122	17.3	122	122	122	104	85	67	48												
57	112	17.2	112	112	112	93	75	56	38												

* These capacities are gross ratings. For net capacity, deduct air blower motor, MBH = 3.415 x kW. Refer to the appropriate Blower Performance Table for the kW of the supply air blower motor.

† These ratings include condenser fan motors and the compressor motors but not the supply air blower motor.

TABLE 10: ELECTRICAL DATA DH078 (6-1/2 TON) HIGH EFFICIENCY W/O PWRD CONVENIENCE OUTLET

Voltage	Compressors		OD Fan Motors	Supply Blower Motor FLA		Pwr Exh Motor	Pwr Conv Outlet	Electric Heater Model No.	Actual KW	Heater Amps	Min. Circuit Ampacity (Amps)		MCA w/Power Exhaust (Amps)		Max Fuse* Size (Amps)		Max Fuse Size w/Power Exhaust (Amps)			
	RLA	LRA	FLA	1.5	2	FLA	FLA				1.5	2	1.5	2	1.5	2	1.5	2	1.5	2
	ea.	ea.	ea.	HP	HP						HP	HP	HP	HP	HP	HP	HP	HP	HP	HP
208	9.0	72.0	1.5	6.2	8.2	5.5	0.0	None	--	--	29.5	31.5	35.0	37.0	35	40	40	45		
								2TP04540925	6.8	18.9	31.3	33.8	38.2	40.7	35	40	40	45		
								2TP04541825	13.5	37.5	54.6	57.1	61.5	64.0	60	60	70	70		
								2TP04542425	18	50.0	70.2	72.7	77.1	79.6	80	80	80	80		
								2TP04543625	25.5	70.8	96.2	98.7	103.1	105.6	100	100	110	110		
230	9.0	72.0	1.5	6.2	8.2	5.5	0.0	None	--	--	29.5	31.5	35.0	37.0	35	40	40	45		
								2TP04540925	9	21.7	34.8	37.3	41.7	44.2	35	40	45	45		
								2TP04541825	18	43.3	61.9	64.4	68.8	71.3	70	70	70	80		
								2TP04542425	24	57.7	79.9	82.4	86.8	89.3	80	90	90	90		
								2TP04543625	34	81.8	110.0	112.5	116.9	119.4	110	125	125	125		
460	5.8	45.0	0.8	3.1	4.1	2.2	0.0	None	--	--	17.8	18.8	20	21	20	20	25	25		
								2TP04540946	9	11.3	17.8	18.8	20.2	21.4	20	20	25	25		
								2TP04541846	18	22.6	30.9	32.2	33.7	34.9	35	35	35	35		
								2TP04542446	24	30.1	40	41.2	42.7	44	40	45	45	45		
								2TP04543646	34	42.7	55	56.2	57.7	59	60	60	60	60		
575	4.5	36.0	0.6	2.4	3.6	1.8	0.0	None	--	--	13.7	14.9	15.5	16.7	15	15	20	20		
								2TP04540958	9	9.0	13.8	15.3	16.1	17.6	15	20	20	20		
								2TP04541858	18	18.1	24.7	26.2	26.9	28.4	25	30	30	30		
								2TP04542458	24	24.1	31.9	33.4	34.1	35.6	35	35	35	40		
								2TP04543658	34	34.1	43.9	45.4	46.1	47.6	45	50	50	50		

TABLE 11: ELECTRICAL DATA DH078 (6-1/2 TON) HIGH EFFICIENCY WITH PWRD CONVENIENCE OUTLET

Voltage	Compressors		OD Fan Motors	Supply Blower Motor FLA		Pwr Exh Motor	Pwr Conv Outlet	Electric Heater Model No.	Actual KW	Heater Amps	Min. Circuit Ampacity (Amps)		MCA w/Power Exhaust (Amps)		Max Fuse* Size (Amps)		Max Fuse Size w/Power Exhaust (Amps)			
	RLA	LRA	FLA	1.5	2	FLA	FLA				1.5	2	1.5	2	1.5	2	1.5	2	1.5	2
	ea.	ea.	ea.	HP	HP						HP	HP	HP	HP	HP	HP	HP	HP	HP	HP
208	9.0	72.0	1.5	6.2	8.2	5.5	10.0	None	--	--	39.7	41.7	45.2	47.2	45	50	50	50		
								2TP04540925	6.8	18.9	43.8	46.3	50.7	53.2	45	50	60	60		
								2TP04541825	13.5	37.5	67.1	69.6	74.0	76.5	70	70	80	80		
								2TP04542425	18	50.0	82.7	85.2	89.6	92.1	90	90	90	100		
								2TP04543625	25.5	70.8	108.7	111.2	115.6	118.1	110	125	125	125		
230	9.0	72.0	1.5	6.2	8.2	5.5	10.0	None	--	--	39.7	41.7	45.2	47.2	45	50	50	50		
								2TP04540925	9	21.7	47.3	49.8	54.2	56.7	50	50	60	60		
								2TP04541825	18	43.3	74.4	76.9	81.3	83.8	80	80	90	90		
								2TP04542425	24	57.7	92.4	94.9	99.3	101.8	100	100	100	110		
								2TP04543625	34	81.8	122.5	125.0	129.4	131.9	125	125	150	150		
460	5.8	45.0	0.8	3.1	4.1	2.2	5.0	None	--	--	22.8	23.8	25	26	25	25	30	30		
								2TP04540946	9	11.3	23.7	24.9	26.4	27.7	25	25	30	30		
								2TP04541846	18	22.6	37.2	38.4	39.9	41.2	40	40	40	45		
								2TP04542446	24	30.1	46.2	47.5	49	50.2	50	50	50	60		
								2TP04543646	34	42.7	61.2	62.5	64	65.2	70	70	70	70		
575	4.5	36.0	0.6	2.4	3.6	1.8	4.0	None	--	--	17.7	18.9	19.5	20.7	20	20	20	25		
								2TP04540958	9	9.0	18.8	20.3	21.1	22.6	20	25	25	25		
								2TP04541858	18	18.1	29.7	31.2	31.9	33.4	30	35	35	35		
								2TP04542458	24	24.1	36.9	38.4	39.1	40.6	40	40	40	45		
								2TP04543658	34	34.1	48.9	50.4	51.1	52.6	50	60	60	60		

TABLE 12: ELECTRICAL DATA DH090 (7-1/2 TON) HIGH EFFICIENCY W/O PWRD CONVENIENCE OUTLET

Voltage	Compressors		OD Fan Motors	Supply Blower Motor FLA		Pwr Exh Motor	Pwr Conv Outlet	Electric Heater Model No.	Actual KW	Heater Amps	Min. Circuit Ampacity (Amps)		MCA w/Power Exhaust (Amps)		Max Fuse* Size (Amps)		Max Fuse Size w/Power Exhaust (Amps)			
	RLA	LRA	FLA	2 HP	3 HP	FLA	FLA				2 HP	3 HP	2 HP	3 HP	2 HP	3 HP	2 HP	3 HP		
	ea.	ea.	ea.																	
208	14.1	110.0	1.5	8.2	10.9	5.5	0.0	None	--	--	42.9	45.6	48.4	51.1	50	50	60	60		
								2TP04540925	6.8	18.9	42.9	45.6	48.4	51.1	50	50	60	60	60	60
								2TP04541825	13.5	37.5	57.1	60.5	64.0	67.3	60	70	70	70	70	70
								2TP04542425	18.0	50.0	72.7	76.1	79.6	83.0	80	80	80	80	80	90
								2TP04543625	25.5	70.8	98.7	102.1	105.6	109.0	100	110	110	110	110	110
230	14.1	110.0	1.5	8.2	10.9	5.5	0.0	None	--	--	42.9	45.6	48.4	51.1	50	50	60	60		
								2TP04540925	9	21.7	42.9	45.6	48.4	51.1	50	50	60	60	60	60
								2TP04541825	18	43.3	64.4	67.8	71.3	74.6	70	70	70	80	80	80
								2TP04542425	24	57.7	82.4	85.8	89.3	92.7	90	90	90	90	100	100
								2TP04543625	34	81.8	112.5	115.9	119.4	122.7	125	125	125	125	125	125
460	7.1	54.0	0.8	4.1	5.3	2.2	0.0	None	--	--	21.7	22.9	23.9	25.1	25	25	30	30		
								2TP04540946	9.0	11.3	21.7	22.9	23.9	25.1	25	25	30	30	30	30
								2TP04541846	18.0	22.6	32.2	33.7	34.9	36.4	35	35	35	40	40	40
								2TP04542446	24.0	30.1	41.2	42.7	44.0	45.5	45	45	45	45	50	50
								2TP04543646	34.0	42.7	56.2	57.7	59.0	60.5	60	60	60	60	60	70
575	5.8	44.0	0.6	3.6	4.1	1.8	0.0	None	--	--	17.9	18.4	19.7	20.2	20	20	25	25		
								2TP04540958	9.0	9.0	17.9	18.4	19.7	20.2	20	20	25	25	25	25
								2TP04541858	18.0	18.1	26.2	26.8	28.4	29.0	30	30	30	30	30	30
								2TP04542458	24.0	24.1	33.4	34.0	35.6	36.2	35	35	40	40	40	40
								2TP04543658	34.0	34.1	45.4	46.0	47.6	48.3	50	50	50	50	50	50

TABLE 13: ELECTRICAL DATA DH090 (7-1/2 TON) HIGH EFFICIENCY WITH PWRD CONVENIENCE OUTLET

Voltage	Compressors		OD Fan Motors	Supply Blower Motor FLA		Pwr Exh Motor	Pwr Conv Outlet	Electric Heater Model No.	Actual KW	Heater Amps	Min. Circuit Ampacity (Amps)		MCA w/Power Exhaust (Amps)		Max Fuse* Size (Amps)		Max Fuse Size w/Power Exhaust (Amps)			
	RLA	LRA	FLA	2 HP	3 HP	FLA	FLA				2 HP	3 HP	2 HP	3 HP	2 HP	3 HP	2 HP	3 HP		
	ea.	ea.	ea.																	
208	14.1	110.0	1.5	8.2	10.9	5.5	10.0	None	--	--	52.9	55.6	58.4	61.1	60	60	70	70		
								2TP04540925	6.8	18.9	52.9	55.6	58.4	61.1	60	60	70	70	70	70
								2TP04541825	13.5	37.5	69.6	73.0	76.5	79.8	70	80	80	80	80	80
								2TP04542425	18.0	50.0	85.2	88.6	92.1	95.5	90	90	100	100	100	100
								2TP04543625	25.5	70.8	111.2	114.6	118.1	121.5	125	125	125	125	125	125
230	14.1	110.0	1.5	8.2	10.9	5.5	10.0	None	--	--	52.9	55.6	58.4	61.1	60	60	70	70		
								2TP04540925	9	21.7	52.9	55.6	58.4	61.1	60	60	70	70	70	70
								2TP04541825	18	43.3	76.9	80.3	83.8	87.1	80	90	90	90	90	90
								2TP04542425	24	57.7	94.9	98.3	101.8	105.2	100	100	110	110	110	110
								2TP04543625	34	81.8	125.0	128.4	131.9	135.2	125	150	150	150	150	150
460	7.1	54.0	0.8	4.1	5.3	2.2	5.0	None	--	--	26.7	27.9	28.9	30.1	30	30	35	35		
								2TP04540946	9.0	11.3	26.7	27.9	28.9	30.1	30	30	35	35	35	35
								2TP04541846	18.0	22.6	38.4	39.9	41.2	42.7	40	40	45	45	45	45
								2TP04542446	24.0	30.1	47.5	49.0	50.2	51.7	50	50	60	60	60	60
								2TP04543646	34.0	42.7	62.5	64.0	65.2	66.7	70	70	70	70	70	70
575	5.8	44.0	0.6	3.6	4.1	1.8	4.0	None	--	--	21.9	22.4	23.7	24.2	25	25	25	25		
								2TP04540958	9.0	9.0	21.9	22.4	23.7	24.2	25	25	25	25	25	25
								2TP04541858	18.0	18.1	31.2	31.8	33.4	34.0	35	35	35	35	35	35
								2TP04542458	24.0	24.1	38.4	39.0	40.6	41.2	40	40	45	45	45	45
								2TP04543658	34.0	34.1	50.4	51.0	52.6	53.3	60	60	60	60	60	60

TABLE 14: ELECTRICAL DATA DH102 (8-1/2 TON) HIGH EFFICIENCY W/O PWRD CONVENIENCE OUTLET

Voltage	Compressors		OD Fan Motors	Supply Blower Motor FLA		Pwr Exh Motor	Pwr Conv Outlet	Electric Heater Model No.	Actual KW	Heater Amps	Min. Circuit Ampacity (Amps)		MCA w/Power Exhaust (Amps)		Max Fuse* Size (Amps)		Max Fuse Size w/Power Exhaust (Amps)			
	RLA ea.	LRA ea.	FLA ea.	3 HP	3 HP	FLA	FLA				3 HP	3 HP	3 HP	3 HP	3 HP	3 HP	3 HP	3 HP	3 HP	3 HP
208	11.7	88.0	3.5	10.9	10.9	5.5	0.0	None	--	--	44.2	44.2	49.7	49.7	50	50	60	60		
								2TP04540925	6.8	18.9	44.2	44.2	49.7	49.7	50	50	60	60	60	60
								2TP04541825	13.5	37.5	60.5	60.5	67.3	67.3	70	70	80	70	70	70
								2TP04542425	18	50.0	76.1	76.1	83.0	83.0	80	80	90	90	90	90
								2TP04543625	25.5	70.8	102.1	102.1	109.0	109.0	110	110	110	110	110	110
230	11.7	88.0	3.5	10.9	10.9	5.5	0.0	None	--	--	44.2	44.2	50.4	50.4	50	50	60	60		
								2TP04540925	9	21.7	44.2	44.2	50.4	50.4	50	50	60	60	60	60
								2TP04541825	18	43.3	67.8	67.8	74.6	74.6	70	70	80	80	80	80
								2TP04542425	24	57.7	85.8	85.8	92.7	92.7	90	90	100	100	100	100
								2TP04543625	34	81.8	115.9	115.9	122.7	122.7	125	125	125	125	125	125
460	6.4	42.0	1.6	5.3	5.3	2.2	0.0	None	--	--	22.9	22.9	25.1	25.1	25	25	30	30		
								2TP04540946	9	11.3	22.9	22.9	25.1	25.1	25	25	30	30	30	30
								2TP04541846	18	22.6	33.7	33.7	36.4	36.4	35	35	40	40	40	40
								2TP04542446	24	30.1	42.7	42.7	45.5	45.5	45	45	50	50	50	50
								2TP04543646	34	42.7	57.7	57.7	60.5	60.5	60	60	70	70	70	70
575	5.1	36.0	1.3	4.1	4.1	1.8	0.0	None	--	--	18.2	18.2	20	20	20	20	25	25		
								2TP04540958	9	9.0	18.2	18.2	20	20	20	20	25	25	25	25
								2TP04541858	18	18.1	26.8	26.8	29	29	30	30	30	30	30	30
								2TP04542458	24	24.1	34	34	36.2	36.2	35	35	40	40	40	40
								2TP04543658	34	34.1	46	46	48.3	48.3	50	50	50	50	50	50

TABLE 15: ELECTRICAL DATA DH102 (8-1/2 TON) HIGH EFFICIENCY WITH PWRD CONVENIENCE OUTLET

Voltage	Compressors		OD Fan Motors	Supply Blower Motor FLA		Pwr Exh Motor	Pwr Conv Outlet	Electric Heater Model No.	Actual KW	Heater Amps	Min. Circuit Ampacity (Amps)		MCA w/Power Exhaust (Amps)		Max Fuse* Size (Amps)		Max Fuse Size w/Power Exhaust (Amps)			
	RLA ea.	LRA ea.	FLA ea.	3 HP	3 HP	FLA	FLA				3 HP	3 HP	3 HP	3 HP	3 HP	3 HP	3 HP	3 HP	3 HP	3 HP
208	11.7	88.0	3.5	10.9	10.9	5.5	10.0	None	--	--	54.2	54.2	59.7	59.7	60	60	70	70		
								2TP04540925	6.8	18.9	54.2	54.2	59.7	59.7	60	60	70	70	70	70
								2TP04541825	13.5	37.5	73.0	73.0	79.8	79.8	80	80	80	80	80	80
								2TP04542425	18	50.0	88.6	88.6	95.5	95.5	90	90	100	100	100	100
								2TP04543625	25.5	70.8	114.6	114.6	121.5	121.5	125	125	125	125	125	125
230	11.7	88.0	3.5	10.9	10.9	5.5	10.0	None	--	--	54.2	54.2	59.7	59.7	60	60	70	70		
								2TP04540925	9	21.7	54.2	54.2	59.7	59.7	60	60	70	70	70	70
								2TP04541825	18	43.3	80.3	80.3	87.1	87.1	90	90	90	90	90	90
								2TP04542425	24	57.7	98.3	98.3	105.2	105.2	100	100	110	110	110	110
								2TP04543625	34	81.8	128.4	128.4	135.2	135.2	150	150	150	150	150	150
460	6.4	42.0	1.6	5.3	5.3	2.2	10.0	None	--	--	27.9	27.9	30.1	30.1	30	30	35	35		
								2TP04540946	9	11.3	27.9	27.9	30.1	30.1	30	30	35	35	35	35
								2TP04541846	18	22.6	39.9	39.9	42.7	42.7	40	40	45	45	45	45
								2TP04542446	24	30.1	49	49	51.7	51.7	50	50	60	60	60	60
								2TP04543646	34	42.7	64	64	66.7	66.7	70	70	70	70	70	70
575	5.1	36.0	1.3	4.1	4.1	1.8	10.0	None	--	--	22.2	22.2	24	24	25	25	25	25		
								2TP04540958	9	9.0	22.2	22.2	24	24	24	25	25	25	25	25
								2TP04541858	18	18.1	31.8	31.8	34	34	35	35	35	35	35	35
								2TP04542458	24	24.1	39	39	41.2	41.2	40	40	45	45	45	45
								2TP04543658	34	34.1	51	51	53.3	53.3	60	60	60	60	60	60

TABLE 16: ELECTRICAL DATA DH120 (10 TON) HIGH EFFICIENCY W/O PWRD CONVENIENCE OUTLET

Voltage	Compressors		OD Fan Motors	Supply Blower Motor FLA		Pwr Exh Motor	Pwr Conv Outlet	Electric Heater Model No.	Actual KW	Heater Amps	Min. Circuit Ampacity (Amps)		MCA w/Power Exhaust (Amps)		Max Fuse* Size (Amps)		Max Fuse* Size w/Power Exhaust (Amps)			
	RLA ea.	LRA ea.	FLA ea.	2 HP	3 HP	FLA	FLA				2 HP	3 HP	2 HP	3 HP	2 HP	3 HP	2 HP	3 HP	2 HP	3 HP
	208	16.0	137.0	3.5	8.2	10.9	5.5				0.0	None	--	--	51.2	53.9	56.7	59.4	60	60
2TP04521825								13.5	37.5	57.1		60.5	64.0	67.3	60	70	70	70		
2TP04522425								18	50.0	72.7		76.1	79.6	83.0	80	80	80	90		
2TP04523625								25.5	70.8	98.7		102.1	105.6	109.0	100	110	110	110		
2TP04525425								40.6	112.7	151.1		154.5	158.0	161.4	175	175	175	175		
230	16.0	137.0	3.5	8.2	10.9	5.5	0.0	None	--	--	51.2	53.9	56.7	59.4	60	60	70	70		
								2TP04521825	18	43.3	64.4	67.8	71.3	74.6	70	70	80	80		
								2TP04522425	24	57.7	82.4	85.8	89.3	92.7	90	90	90	100		
								2TP04523625	34	81.8	112.5	115.9	119.4	122.7	125	125	125	125		
								2TP04525425	54	129.9	140.2	143.5	147.0	150.4	150	175	175	175		
460	8.3	69.0	1.6	4.1	5.3	2.2	0.0	None	--	--	26	27.2	28.2	29.4	30	35	35	35		
								2TP04521846	18	22.6	32.2	33.7	34.9	36.4	35	35	35	40		
								2TP04522446	24	30.1	41.2	42.7	44	45.5	45	45	45	50		
								2TP04523646	34	42.7	56.2	57.7	59	60.5	60	60	60	70		
								2TP04525446	54	67.8	70.1	71.6	72.8	74.3	80	80	80	80		
575	6.4	58.0	1.3	3.6	4.1	1.8	0.0	None	--	--	20.6	21.1	22.4	22.9	25	25	25	25		
								2TP04521858	18	18.1	26.2	26.8	28.4	29	30	30	30	30		
								2TP04522458	24	24.1	33.4	34	35.6	36.2	35	35	40	40		
								2TP04523658	34	34.1	45.4	46	47.6	48.3	50	50	50	50		
								2TP04525458	54	54.2	56.5	57.1	58.7	59.3	70	70	70	70		

* Maximum HACR breaker of the same AMP size is applicable.

TABLE 17: ELECTRICAL DATA DH120 (10 TON) HIGH EFFICIENCY WITH PWRD CONVENIENCE OUTLET

Voltage	Compressors		OD Fan Motors	Supply Blower Motor FLA		Pwr Exh Motor	Pwr Conv Outlet	Electric Heater Model No.	Actual KW	Heater Amps	Min. Circuit Ampacity (Amps)		MCA w/Power Exhaust (Amps)		Max Fuse* Size (Amps)		Max Fuse* Size w/Power Exhaust (Amps)			
	RLA ea.	LRA ea.	FLA ea.	2 HP	3 HP	FLA	FLA				2 HP	3 HP	2 HP	3 HP	2 HP	3 HP	2 HP	3 HP	2 HP	3 HP
	208	16.0	137.0	3.5	8.2	10.9	5.5				10.0	None	--	--	61.2	63.9	66.7	69.4	70	70
2TP04521825								13.5	37.5	69.6		73.0	76.5	79.8	70	80	80	80		
2TP04522425								18	50.0	85.2		88.6	92.1	95.5	90	90	100	100		
2TP04523625								25.5	70.8	111.2		114.6	118.1	121.5	125	125	125	125		
2TP04525425								40.6	112.7	163.6		167.0	170.5	173.9	175	175	175	175		
230	16.0	137.0	3.5	8.2	10.9	5.5	10.0	None	--	--	61.2	63.9	66.7	69.4	70	70	80	80		
								2TP04521825	18	43.3	76.9	80.3	83.8	87.1	80	90	90	90		
								2TP04522425	24	57.7	94.9	98.3	101.8	105.2	100	100	110	110		
								2TP04523625	34	81.8	125.0	128.4	131.9	135.2	125	150	150	150		
								2TP04525425	54	129.9	152.7	156.0	159.5	162.9	175	175	175	175		
460	8.3	69.0	1.6	4.1	5.3	2.2	5.0	None	--	--	31	32.2	33.2	34.4	35	40	40	40		
								2TP04521846	18	22.6	38.4	39.9	41.2	42.7	40	40	45	45		
								2TP04522446	24	30.1	47.5	49	50.2	51.7	50	50	60	60		
								2TP04523646	34	42.7	62.5	64	65.2	66.7	70	70	70	70		
								2TP04525446	54	67.8	76.3	77.8	79.1	80.6	90	90	90	90		
575	6.4	58.0	1.3	3.6	4.1	1.8	4.0	None	--	--	24.6	25.1	26.4	26.9	30	30	30	30		
								2TP04521858	18	18.1	31.2	31.8	33.4	34	35	35	35	35		
								2TP04522458	24	24.1	38.4	39	40.6	41.2	40	40	45	45		
								2TP04523658	34	34.1	50.4	51	52.6	53.3	60	60	60	60		
								2TP04525458	54	54.2	61.5	62.1	63.7	64.3	70	70	70	70		

* Maximum HACR breaker of the same AMP size is applicable.

TABLE 18: ELECTRICAL DATA DH150 (12-1/2 TON) HIGH EFFICIENCY W/O PWRD CONVENIENCE OUTLET

Voltage	Compressors		OD Fan Motors	Supply Blower Motor FLA		Pwr Exh Motor	Pwr Conv Outlet	Electric Heater Model No.	Actual KW	Heater Amps	Min. Circuit Ampacity (Amps)		MCA w/Power Exhaust (Amps)		Max Fuse* Size (Amps)		Max Fuse* Size w/Power Exhaust (Amps)	
	RLA ea.	LRA ea.	FLA ea.	3 HP	5 HP	FLA	FLA				3 HP	5 HP	3 HP	5 HP	3 HP	5 HP	3 HP	5 HP
	208	18.9	146.0	3.5	10.9	16.1	5.5				0.0	None	--	--	60.4	65.6	65.9	71.1
								2TP04521825	13.5	37.5	60.5	67.0	67.3	73.8	70	80	80	90
								2TP04522425	18	50.0	76.1	82.6	83.0	89.5	80	90	90	90
								2TP04523625	25.5	70.8	102.1	108.6	109.0	115.5	110	110	110	125
								2TP04525425	40.6	112.7	154.5	161.0	161.4	167.9	175	175	175	175
230	18.9	146.0	3.5	10.9	16.1	5.5	0.0	None	--	--	60.4	65.6	65.9	71.1	70	80	80	90
								2TP04521825	18	43.3	67.8	74.3	74.6	81.1	70	80	80	90
								2TP04522425	24	57.7	85.8	92.3	92.7	99.2	90	100	100	100
								2TP04523625	34	81.8	115.9	122.4	122.7	129.2	125	125	125	150
								2TP04525425	54	129.9	143.5	150.0	150.4	156.9	175	175	175	175
460	9.5	73.0	1.6	5.3	8.1	2.2	0.0	None	--	--	29.9	32.7	32.1	34.9	35	40	40	40
								2TP04521846	18	22.6	33.7	37.2	36.4	39.9	35	40	40	40
								2TP04522446	24	30.1	42.7	46.2	45.5	49	45	50	50	50
								2TP04523646	34	42.7	57.7	61.2	60.5	64	60	70	70	70
								2TP04525446	54	67.8	71.6	75.1	74.3	77.8	80	90	80	90
575	7.6	58.4	1.3	4.1	6.0	1.8	0.0	None	--	--	23.8	25.7	25.6	27.5	30	30	30	35
								2TP04521858	18	18.1	26.8	29.2	29	31.4	30	30	30	35
								2TP04522458	24	24.1	34	36.4	36.2	38.6	35	40	40	40
								2TP04523658	34	34.1	46	48.4	48.3	50.6	50	50	50	60
								2TP04525458	54	54.2	57.1	59.5	59.3	61.7	70	70	70	70

* Maximum HACR breaker of the same AMP size is applicable.

TABLE 19: ELECTRICAL DATA DH150 (12-1/2 TON) HIGH EFFICIENCY W/PWRD CONVENIENCE OUTLET

Voltage	Compressors		OD Fan Motors	Supply Blower Motor FLA		Pwr Exh Motor	Pwr Conv Outlet	Electric Heater Model No.	Actual KW	Heater Amps	Min. Circuit Ampacity (Amps)		MCA w/Power Exhaust (Amps)		Max Fuse* Size (Amps)		Max Fuse* Size w/Power Exhaust (Amps)	
	RLA ea.	LRA ea.	FLA ea.	3 HP	5 HP	FLA	FLA				3 HP	5 HP	3 HP	5 HP	3 HP	5 HP	3 HP	5 HP
	208	18.9	146.0	3.5	10.9	16.1	5.5				10.0	None	--	--	70.4	75.6	75.9	81.1
								2TP04521825	13.5	37.5	73.0	79.5	79.8	86.3	80	90	90	100
								2TP04522425	18	50.0	88.6	95.1	95.5	102.0	90	100	100	110
								2TP04523625	25.5	70.8	114.6	121.1	121.5	128.0	125	125	125	150
								2TP04525425	40.6	112.7	167.0	173.5	173.9	180.4	175	175	175	200
230	18.9	146.0	3.5	10.9	16.1	5.5	10.0	None	--	--	70.4	75.6	75.9	81.1	80	90	90	100
								2TP04521825	18	43.3	80.3	86.8	87.1	93.6	90	90	90	100
								2TP04522425	24	57.7	98.3	104.8	105.2	111.7	100	110	110	125
								2TP04523625	34	81.8	128.4	134.9	135.2	141.7	150	150	150	150
								2TP04525425	54	129.9	156.0	162.5	162.9	169.4	175	175	175	175
460	9.5	73.0	1.6	5.3	8.1	2.2	5.0	None	--	--	34.9	37.7	37.1	39.9	40	45	45	45
								2TP04521846	18	22.6	39.9	43.4	42.7	46.2	40	45	45	50
								2TP04522446	24	30.1	49	52.5	51.7	55.2	50	60	60	60
								2TP04523646	34	42.7	64	67.5	66.7	70.2	70	70	70	80
								2TP04525446	54	67.8	77.8	81.3	80.6	84.1	90	90	90	90
575	7.6	58.4	1.3	4.1	6.0	1.8	4.0	None	--	--	27.8	29.7	29.6	31.5	35	35	35	35
								2TP04521858	18	18.1	31.8	34.2	34	36.4	35	35	35	40
								2TP04522458	24	24.1	39	41.4	41.2	43.6	40	45	45	45
								2TP04523658	34	34.1	51	53.4	53.3	55.6	60	60	60	60
								2TP04525458	54	54.2	62.1	64.5	64.3	66.7	70	70	70	70

* Maximum HACR breaker of the same AMP size is applicable.

TABLE 20: ELECTRIC HEAT MULTIPLIERS

VOLTAGE		kW Cap. Multiplier
NOMINAL	RATING	
240	208	0.75
	230	0.92
480	460	0.92
600	575	0.92

NOTE: Electric heaters are rated at nominal voltage. Use this table to determine the electric heat capacity for heaters supplied at lower voltages.

NOTES FOR TABLES 21 THROUGH TABLE 30:

- Blower performance includes dry coil and 2" throwaway filters.
- Blower performance for gas heat includes the maximum number of heat tubes available for each tonnage.

ESP (External Static Pressure) given is that available for the supply and return air duct system. All internal resistances have been deducted from the total static pressure of the blower.

TABLE 21: DH078 (6-1/2) SIDE SHOT BLOWER PERFORMANCE

CFM	External Static Pressure																													
	0.2		0.4		0.6		0.8		1.0		1.2		1.4		1.6		1.8		2.0											
	RPM	BHP	Watts	RPM	BHP	Watts	RPM	BHP	Watts	RPM	BHP	Watts	RPM	BHP	Watts	RPM	BHP	Watts	RPM	BHP	Watts									
1800	705	0.31	291	776	0.50	466	844	0.67	622	910	0.82	761	977	0.95	888	1045	1.08	1005	1116	1.20	1115	1192	1.31	1220	1274	1.42	1324	1364	1.53	1429
1900	719	0.37	347	790	0.56	522	858	0.73	677	924	0.88	817	991	1.01	944	1059	1.14	1061	1130	1.26	1171	1206	1.37	1276	1288	1.48	1380	1378	1.59	1485
2000	734	0.44	408	805	0.62	582	873	0.79	738	939	0.94	878	1006	1.08	1005	1074	1.20	1121	1146	1.32	1231	1221	1.43	1336	1304	1.54	1440	1393	1.66	1545
2100	751	0.51	472	822	0.69	647	889	0.86	802	956	1.01	942	1023	1.15	1069	1091	1.27	1186	1162	1.39	1296	1238	1.50	1401	1320	1.61	1505	1410	1.73	1610
2200	768	0.58	541	839	0.77	716	907	0.93	871	974	1.08	1011	1040	1.22	1138	1108	1.35	1255	1180	1.46	1364	1266	1.58	1470	1338	1.69	1574	1312	1.84	1714
2300	787	0.66	614	858	0.85	789	926	1.01	945	992	1.16	1084	1069	1.30	1211	1127	1.42	1328	1198	1.54	1438	1274	1.66	1543	1270	1.80	1674	1326	1.92	1793
2400	807	0.74	692	878	0.93	866	946	1.10	1022	1012	1.25	1162	1079	1.38	1289	1147	1.51	1405	1218	1.63	1515	1294	1.74	1620	1284	1.88	1757	1341	2.01	1875
2500	828	0.83	773	899	1.02	948	966	1.18	1103	1033	1.33	1243	1100	1.47	1370	1168	1.59	1487	1239	1.71	1596	1246	1.85	1725	1300	1.98	1844	1356	2.11	1962
2600	849	0.92	858	920	1.11	1033	988	1.28	1189	1055	1.43	1328	1121	1.56	1455	1189	1.69	1572	1209	1.82	1694	1263	1.95	1816	1317	2.08	1935	1373	2.20	2053
2700	872	1.02	948	943	1.20	1122	1011	1.37	1278	1077	1.52	1418	1144	1.66	1544	1174	1.78	1661	1228	1.92	1789	1281	2.05	1911	1335	2.18	2030	1392	2.30	2148
2800	896	1.12	1041	966	1.30	1215	1034	1.47	1371	1101	1.62	1511	1139	1.74	1624	1193	1.89	1760	1247	2.03	1888	1300	2.16	2010	1355	2.28	2128	1400	2.40	2268
2900	920	1.22	1137	991	1.41	1312	1059	1.57	1467	1125	1.72	1607	1159	1.85	1726	1213	2.00	1862	1266	2.13	1990	1320	2.27	2112	1400	2.40	2268	1400	2.40	2268
3000	945	1.33	1237	1016	1.51	1412	1084	1.68	1567	1125	1.81	1684	1180	1.96	1832	1234	2.11	1968	1287	2.25	2095	1400	2.40	2268	1400	2.40	2268	1400	2.40	2268
3100	971	1.44	1341	1042	1.63	1515	1090	1.75	1631	1147	1.92	1793	1202	2.08	1940	1255	2.23	2077	1400	2.40	2268	1400	2.40	2268	1400	2.40	2268	1400	2.40	2268
3200	998	1.55	1448	1069	1.74	1623	1112	1.87	1743	1169	2.04	1905	1224	2.20	2052	1400	2.40	2268	1400	2.40	2268	1400	2.40	2268	1400	2.40	2268	1400	2.40	2268
3300	1025	1.67	1558	1076	1.80	1680	1135	1.99	1858	1192	2.17	2020	1247	2.33	2167	1400	2.40	2268	1400	2.40	2268	1400	2.40	2268	1400	2.40	2268	1400	2.40	2268
3400	1037	1.72	1599	1100	1.93	1797	1159	2.12	1976	1216	2.29	2138	1400	2.40	2268	1400	2.40	2268	1400	2.40	2268	1400	2.40	2268	1400	2.40	2268	1400	2.40	2268
3500	1062	1.85	1720	1124	2.06	1918	1183	2.25	2097	1400	2.40	2268	1400	2.40	2268	1400	2.40	2268	1400	2.40	2268	1400	2.40	2268	1400	2.40	2268	1400	2.40	2268
3600	1087	1.98	1843	1149	2.19	2042	1200	2.40	2268	1400	2.40	2268	1400	2.40	2268	1400	2.40	2268	1400	2.40	2268	1400	2.40	2268	1400	2.40	2268	1400	2.40	2268
3700	1112	2.11	1969	1175	2.33	2168	1220	2.40	2268	1400	2.40	2268	1400	2.40	2268	1400	2.40	2268	1400	2.40	2268	1400	2.40	2268	1400	2.40	2268	1400	2.40	2268

High Horsepower Option Required

TABLE 22: DH090 (7-1/2 TON) SIDE SHOT BLOWER PERFORMANCE

CFM	External Static Pressure																													
	0.2		0.4		0.6		0.8		1.0		1.2		1.4		1.6		1.8		2											
	RPM	BHP	Watts	RPM	BHP	Watts	RPM	BHP	Watts	RPM	BHP	Watts	RPM	BHP	Watts	RPM	BHP	Watts	RPM	BHP	Watts									
2000	745	0.31	292	811	0.51	478	876	0.71	658	939	0.89	827	1001	1.05	980	1061	1.19	1113	1118	1.31	1221	1174	1.46	1361	1227	1.59	1486	1278	1.74	1622
2100	759	0.38	359	825	0.58	545	890	0.78	725	954	0.96	894	1015	1.12	1047	1075	1.27	1180	1133	1.38	1288	1188	1.54	1434	1241	1.67	1559	1292	1.82	1695
2200	774	0.46	429	841	0.66	615	906	0.85	795	969	1.03	964	1031	1.20	1117	1090	1.34	1251	1148	1.46	1359	1204	1.62	1508	1257	1.75	1633	1307	1.90	1769
2300	791	0.54	504	857	0.74	690	922	0.93	870	985	1.11	1039	1047	1.28	1192	1107	1.42	1325	1164	1.54	1433	1220	1.70	1584	1273	1.83	1709	1324	1.98	1845
2400	808	0.62	582	874	0.82	768	939	1.02	948	1002	1.20	1117	1064	1.36	1270	1124	1.51	1403	1182	1.62	1511	1237	1.78	1664	1290	1.92	1789	1341	2.06	1925
2500	826	0.71	664	892	0.91	850	957	1.11	1030	1020	1.29	1199	1082	1.45	1353	1142	1.59	1486	1200	1.71	1594	1255	1.87	1746	1308	2.01	1871	1359	2.15	2007
2600	845	0.81	750	911	1.00	936	976	1.20	1116	1039	1.38	1285	1101	1.54	1438	1161	1.69	1571	1219	1.80	1680	1274	1.97	1832	1327	2.10	1957	1378	2.25	2093
2700	865	0.90	840	931	1.10	1026	996	1.29	1206	1059	1.47	1375	1121	1.64	1528	1181	1.78	1661	1238	1.90	1769	1294	2.06	1922	1347	2.20	2046	1398	2.34	2183
2800	885	1.00	933	952	1.20	1119	1016	1.39	1299	1080	1.58	1468	1141	1.74	1621	1201	1.88	1755	1259	2.00	1863	1314	2.16	2015	1368	2.30	2140	1418	2.44	2276
2900	907	1.11	1030	973	1.30	1216	1038	1.50	1396	1101	1.68	1565	1163	1.84	1718	1222	1.99	1851	1280	2.10	1960	1336	2.27	2113	1389	2.40	2238	1439	2.55	2374
3000	929	1.21	1131	995	1.41	1317	1060	1.61	1497	1123	1.79	1666	1185	1.95	1819	1244	2.09	1952	1302	2.21	2060	1358	2.38	2214	1411	2.51	2339	1461	2.66	2475
3100	951	1.32	1235	1017	1.52	1421	1082	1.72	1601	1146	1.90	1769	1207	2.06	1923	1267	2.21	2056	1325	2.32	2164	1380	2.49	2320	1434	2.62	2445	1484	2.77	2581
3200	975	1.44	1342	1041	1.64	1528	1106	1.83	1708	1169	2.01	1877	1231	2.18	2030	1290	2.32	2163	1348	2.48	2311	1404	2.61	2431	1457	2.74	2555	1507	2.89	2691
3300	999	1.56	1453	1065	1.76	1639	1130	1.95	1819	1193	2.13	1987	1255	2.30	2141	1314	2.47	2304	1372	2.60	2425	1428	2.73	2545	1481	2.86	2670	1531	3.01	2806
3400	1023	1.68	1567	1089	1.88	1753	1154	2.07	1932	1218	2.25	2101	1279	2.46	2293	1339	2.60	2422	1397	2.73	2544	1452	2.86	2664	1505	2.99	2789	1556	3.14	2925
3500	1048	1.81	1684	1115	2.01	1870	1179	2.20	2049	1243	2.44	2273	1304	2.59	2416	1364	2.73	2546	1422	2.86	2667	1478	2.99	2787	1531	3.12	2912	1581	3.27	3048
3600	1074	1.94	1804	1140	2.13	1990	1205	2.33	2170	1269	2.58	2401	1330	2.73	2544	1390	2.87	2673	1448	3.00	2794	1503	3.13	2914	1556	3.26	3039	1633	3.40	3171
3700	1101	2.07	1927	1167	2.27	2113	1232	2.54	2369	1295	2.72	2532	1357	2.87	2676	1416	3.01	2805	1474	3.14	2926	1530	3.27	3046	1583	3.40	3171	1684	3.54	3303
3800	1127	2.20	2053	1194	2.48	2315	1258	2.69	2505	1322	2.86	2669	1383	3.02	2812	1443	3.15	2941	1501	3.29	3062	1556	3.40	3171	1633	3.54	3303	1735	3.68	3435
3900	1155	2.39	2232	1221	2.63	2455	1286	2.84	2645	1349	3.01	2809	1411	3.17	2952	1471	3.31	3081	1556	3.40	3171	1633	3.54	3303	1735	3.68	3435	1836	3.82	3567
4000	1183	2.55	2377	1249	2.79	2600	1314	2.99	2790	1377	3.17	2953	1439	3.32	3097	1494	3.44	3211	1601	3.56	3321	1633	3.68	3435	1735	3.82	3567	1937	3.96	3699
4100	1211	2.71	2525	1277	2.95	2748	1342	3.15	2939	1406	3.33	3102	1467	3.53	3206	1516	3.67	3321	1651	3.79	3435	1684	3.96	3567	1784	4.10	3700	2038	4.10	3841
4200	1240	2.87	2678	1306	3.11	2901	1371	3.32	3091	1439	3.53	3102	1494	3.73	3301	1543	3.81	3435	1701	3.96	3567	1715	4.10	3700	1836	4.23	3841	2139	4.23	3982
4300	1269	3.04	2835	1336	3.28	3058	1406	3.53	3102	1467	3.73	3301	1516	3.96	3567	1576	4.10	3700	1751	4.23	3841	1784	4.40	3841	1836	4.53	3982	2240	4.53	4123
4400	1299	3.21	2996	1365	3.44	3215	1435	3.73	3301	1494	3.96	3567	1543	4.10	3700	1601	4.23	3841	1801	4.40	3982	1836	4.53	3982	1887	4.66	4123	2341	4.66	4264
4500	1329	3.39	3161	1394	3.60	3372	1464	3.96	3567	1516	4.40	3982	1576	4.53	3982	1627	4.66	4123	1851	4.79	4264	1887	4.92	4405	1937	5.05	4546	2442	5.05	4405

High Horsepower Option Required

TABLE 23: DH102 (8-1/2 TON) SIDE SHOT BLOWER PERFORMANCE

CFM	External Static Pressure																											
	0.2		0.4		0.6		0.8		1.0		1.2		1.4		1.6		1.8											
	RPM	BHP	Watts	RPM	BHP	Watts	RPM	BHP	Watts	RPM	BHP	Watts	RPM	BHP	Watts	RPM	BHP	Watts										
2000	802	0.31	288	866	0.55	510	923	0.75	700	1025	1.08	1007	1074	1.22	1137	1124	1.35	1259	1178	1.48	1378	1237	1.61	1503				
2100	813	0.38	354	877	0.62	576	934	0.82	766	986	1.00	930	1036	1.15	1074	1085	1.29	1203	1135	1.42	1325	1189	1.55	1445	1248	1.68	1569	
2200	825	0.45	423	889	0.69	646	946	0.90	836	999	1.07	1000	1048	1.23	1143	1097	1.37	1273	1147	1.50	1394	1201	1.62	1514	1260	1.76	1638	
2300	838	0.53	497	902	0.77	719	959	0.98	909	1012	1.15	1073	1061	1.30	1216	1110	1.44	1346	1160	1.57	1467	1214	1.70	1587	1273	1.84	1712	
2400	852	0.62	573	916	0.85	796	973	1.06	986	1026	1.23	1150	1075	1.39	1293	1124	1.53	1423	1174	1.66	1544	1228	1.79	1664	1287	1.92	1788	
2500	867	0.70	654	931	0.94	877	988	1.14	1067	1040	1.32	1230	1090	1.47	1374	1139	1.61	1504	1189	1.74	1625	1243	1.87	1745	1302	2.01	1869	
2600	882	0.79	739	946	1.03	962	1004	1.24	1152	1056	1.41	1316	1105	1.57	1459	1154	1.70	1589	1204	1.83	1710	1258	1.96	1830	1318	2.10	1954	
2700	899	0.89	829	963	1.13	1051	1020	1.33	1241	1072	1.51	1405	1122	1.66	1548	1170	1.80	1678	1221	1.93	1800	1274	2.06	1919	1334	2.19	2044	
2800	916	0.99	922	980	1.23	1145	1037	1.43	1335	1089	1.61	1498	1139	1.76	1642	1187	1.90	1771	1238	2.03	1893	1292	2.16	2013	1328	2.28	2128	
2900	934	1.09	1020	998	1.33	1243	1055	1.54	1433	1107	1.71	1596	1156	1.87	1740	1205	2.01	1869	1255	2.14	1991	1309	2.26	2111	1346	2.40	2235	
3000	952	1.20	1122	1016	1.44	1345	1073	1.65	1535	1125	1.82	1698	1175	1.98	1842	1224	2.12	1972	1274	2.25	2093	1315	2.38	2215	1365	2.52	2347	
3100	971	1.32	1229	1035	1.56	1451	1092	1.76	1641	1145	1.94	1805	1194	2.09	1949	1243	2.23	2078	1293	2.36	2200	1335	2.50	2333	1385	2.64	2465	
3200	991	1.44	1340	1055	1.68	1562	1112	1.88	1752	1164	2.06	1916	1214	2.21	2059	1263	2.35	2189	1313	2.48	2311	1355	2.64	2456	1406	2.78	2588	
3300	1012	1.56	1455	1076	1.80	1677	1133	2.00	1867	1185	2.18	2031	1234	2.33	2175	1283	2.47	2304	1327	2.63	2450	1377	2.77	2584	1427	2.91	2716	
3400	1033	1.69	1574	1097	1.93	1797	1154	2.13	1987	1206	2.31	2151	1256	2.46	2294	1304	2.60	2424	1349	2.77	2583	1399	2.91	2717	1449	3.06	2849	
3500	1054	1.82	1698	1118	2.06	1921	1176	2.26	2111	1228	2.44	2274	1277	2.59	2418	1322	2.77	2578	1372	2.92	2720	1421	3.06	2854	1471	3.20	2986	
3600	1077	1.96	1826	1141	2.20	2048	1198	2.40	2238	1250	2.58	2402	1300	2.73	2546	1345	2.92	2720	1395	3.07	2861	1444	3.21	2996	1495	3.36	3128	
3700	1100	2.10	1958	1164	2.34	2180	1221	2.54	2370	1273	2.72	2534	1318	2.91	2711	1369	3.07	2865	1418	3.23	3007	1468	3.37	3141	-----	-----	-----	
3800	1123	2.25	2094	1187	2.49	2316	1244	2.69	2506	1296	2.86	2670	1343	3.07	2861	1393	3.23	3015	1442	3.39	3156	-----	-----	-----	-----	-----	-----	-----
3900	1147	2.40	2234	1211	2.64	2457	1268	2.84	2647	1315	3.05	2843	1367	3.23	3014	1417	3.40	3168	-----	-----	-----	-----	-----	-----	-----	-----	-----	-----
4000	1171	2.55	2378	1236	2.79	2601	1293	2.99	2791	1340	3.22	2999	1392	3.40	3171	-----	-----	-----	-----	-----	-----	-----	-----	-----	-----	-----	-----	-----
4100	1197	2.71	2526	1261	2.95	2749	1311	3.18	2966	1365	3.39	3160	-----	-----	-----	-----	-----	-----	-----	-----	-----	-----	-----	-----	-----	-----	-----	-----
4200	1222	2.87	2678	1286	3.11	2900	1337	3.36	3129	-----	-----	-----	-----	-----	-----	-----	-----	-----	-----	-----	-----	-----	-----	-----	-----	-----	-----	-----
4300	1248	3.04	2834	1306	3.30	3075	-----	-----	-----	-----	-----	-----	-----	-----	-----	-----	-----	-----	-----	-----	-----	-----	-----	-----	-----	-----	-----	-----
4400	1275	3.21	2993	-----	-----	-----	-----	-----	-----	-----	-----	-----	-----	-----	-----	-----	-----	-----	-----	-----	-----	-----	-----	-----	-----	-----	-----	-----
4500	1302	3.39	3156	-----	-----	-----	-----	-----	-----	-----	-----	-----	-----	-----	-----	-----	-----	-----	-----	-----	-----	-----	-----	-----	-----	-----	-----	-----

Optional Drive Required

TABLE 24: DH120 (10 TON) SIDE SHOT BLOWER PERFORMANCE

CFM	External Static Pressure																	
	0.2		0.4		0.6		0.8		1.0		1.2		1.4		1.6		1.8	
	RPM	BHP	Watts	RPM	BHP	Watts	RPM	BHP	Watts	RPM	BHP	Watts	RPM	BHP	Watts	RPM	BHP	Watts
3000	741	1.20	1122	816	1.35	1256	865	1.46	1365	923	1.69	1571	971	1.91	1784	1035	2.04	1906
3100	705	1.13	1049	755	1.25	1167	828	1.41	1314	876	1.54	1431	933	1.75	1628	980	1.99	1851
3200	719	1.18	1100	769	1.31	1218	840	1.48	1376	887	1.61	1501	943	1.81	1691	988	2.06	1922
3300	733	1.24	1156	783	1.37	1274	851	1.55	1443	899	1.69	1575	952	1.89	1760	997	2.14	1997
3400	747	1.30	1216	797	1.43	1336	863	1.62	1514	910	1.77	1653	962	1.97	1834	1006	2.23	2076
3500	761	1.37	1281	811	1.51	1404	874	1.70	1589	922	1.86	1735	972	2.05	1915	1015	2.31	2158
3600	775	1.45	1351	825	1.59	1477	886	1.79	1669	933	1.95	1821	982	2.15	2001	1023	2.41	2244
3700	789	1.53	1426	839	1.67	1556	897	1.88	1753	944	2.05	1911	992	2.24	2092	1032	2.50	2334
3800	803	1.61	1505	853	1.76	1641	909	1.98	1841	956	2.15	2005	1002	2.35	2190	1041	2.60	2427
3900	817	1.70	1589	867	1.86	1731	920	2.07	1934	967	2.26	2103	1012	2.46	2293	1050	2.71	2524
4000	831	1.80	1678	881	1.96	1827	932	2.18	2031	979	2.37	2205	1022	2.58	2402	1058	2.82	2625
4100	845	1.90	1771	895	2.07	1928	943	2.29	2132	990	2.48	2311	1032	2.70	2516	1067	2.93	2729
4200	859	2.01	1869	909	2.18	2035	955	2.40	2238	1001	2.60	2422	1042	2.83	2637	1076	3.04	2838
4300	873	2.12	1972	923	2.30	2148	966	2.52	2348	1013	2.72	2536	1052	2.96	2763	1084	3.16	2949
4400	887	2.23	2079	937	2.43	2266	978	2.64	2463	1024	2.85	2654	1062	3.11	2895	1093	3.29	3065
4500	901	2.35	2191	951	2.56	2390	989	2.77	2581	1036	2.98	2776	1072	3.25	3032	1102	3.42	3184
4600	915	2.48	2308	965	2.70	2519	1001	2.90	2705	1047	3.11	2902	1082	3.41	3175	*****	*****	*****
4700	929	2.61	2430	979	2.85	2654	1012	3.04	2832	1058	3.25	3032	*****	*****	*****	*****	*****	*****
4800	943	2.74	2556	993	3.00	2795	1024	3.18	2964	1070	3.40	3166	*****	*****	*****	*****	*****	*****
4900	957	2.88	2687	1007	3.15	2941	1036	3.33	3100	*****	*****	*****	*****	*****	*****	*****	*****	*****
5000	971	3.03	2823	1021	3.32	3093	*****	*****	*****	*****	*****	*****	*****	*****	*****	*****	*****	*****

High Horsepower Option Required

TABLE 25: DH150 (12-1/2 TON) SIDE SHOT BLOWER PERFORMANCE

CFM	External Static Pressure																													
	0.2		0.4		0.6		0.8		1.0		1.2		1.4		1.6		1.8		2.0											
	RPM	BHP	Watts	RPM	BHP	Watts	RPM	BHP	Watts	RPM	BHP	Watts	RPM	BHP	Watts	RPM	BHP	Watts	RPM	BHP	Watts									
3700	---	---	---	---	---	---	874	1.93	1801	927	2.04	1906	984	2.27	2113	1037	2.41	2245	1089	2.57	2399	1138	2.68	2499	1178	2.82	2628			
3800	---	---	---	840	1.82	1699	888	2.01	1871	941	2.14	1993	997	2.36	2202	1048	2.50	2334	1099	2.67	2485	1146	2.77	2586	1186	2.93	2728			
3900	---	---	---	---	---	---	855	1.92	1786	903	2.09	1947	954	2.24	2085	1009	2.46	2295	1060	2.60	2427	1109	2.76	2576	1155	2.88	2680	1195	3.04	2834
4000	---	---	---	---	---	---	870	2.01	1877	917	2.18	2028	968	2.34	2182	1022	2.57	2392	1071	2.71	2524	1120	2.87	2672	1163	2.98	2780	1204	3.16	2947
4100	---	---	---	---	---	---	885	2.12	1973	932	2.27	2115	982	2.45	2283	1035	2.68	2494	1083	2.82	2626	1130	2.98	2774	1171	3.10	2887	1212	3.29	3066
4200	---	---	---	834	2.11	1970	900	2.22	2072	946	2.37	2207	996	2.56	2390	1048	2.79	2601	1094	2.93	2733	1140	3.09	2881	1179	3.22	3000	1221	3.42	3192
4300	---	---	---	851	2.19	2042	915	2.33	2175	961	2.47	2305	1009	2.68	2501	1061	2.91	2712	1106	3.05	2844	1150	3.21	2993	1188	3.35	3119	1230	3.57	3324
4400	---	---	---	868	2.28	2121	931	2.45	2283	975	2.58	2409	1023	2.81	2616	1074	3.03	2828	1117	3.18	2960	1160	3.34	3111	1196	3.48	3245	1239	3.71	3462
4500	822	2.13	1990	885	2.37	2208	946	2.57	2395	990	2.70	2518	1037	2.94	2736	1087	3.16	2948	1129	3.30	3080	1171	3.47	3234	1204	3.62	3377	1247	3.87	3607
4600	838	2.23	2083	901	2.47	2301	961	2.69	2511	1004	2.82	2633	1051	3.07	2862	1099	3.30	3072	1141	3.44	3204	1181	3.61	3362	1212	3.77	3515	1256	4.03	3758
4700	854	2.34	2184	918	2.58	2401	976	2.82	2631	1019	2.95	2753	1064	3.21	2991	1112	3.43	3201	1152	3.58	3333	1191	3.75	3496	1221	3.93	3659	1265	4.20	3916
4800	870	2.46	2291	935	2.69	2508	991	2.96	2755	1033	3.09	2879	1078	3.35	3126	1125	3.58	3335	1164	3.72	3467	1201	3.90	3635	1229	4.09	3810	1273	4.38	4080
4900	887	2.58	2406	952	2.81	2622	1007	3.09	2883	1048	3.23	3011	1092	3.50	3265	1138	3.73	3473	1175	3.87	3605	1211	4.05	3779	1237	4.26	3967	1282	4.56	4250
5000	903	2.71	2527	968	2.94	2744	1022	3.24	3016	1062	3.38	3148	1105	3.66	3409	1151	3.88	3616	1187	4.02	3748	1222	4.21	3929	1245	4.43	4131	1291	4.75	4427
5100	919	2.85	2656	985	3.08	2872	1037	3.38	3152	1077	3.53	3291	1119	3.82	3558	1164	4.04	3763	1198	4.18	3895	1232	4.38	4083	1254	4.61	4301	1300	4.95	4610
5200	936	2.99	2791	1002	3.23	3007	1052	3.53	3293	1091	3.69	3439	1133	3.98	3711	1177	4.20	3914	1210	4.34	4046	1242	4.55	4244	1262	4.80	4477	1308	5.15	4800
5300	952	3.15	2934	1018	3.38	3149	1067	3.69	3438	1106	3.85	3593	1147	4.15	3869	1189	4.37	4070	1221	4.51	4202	1252	4.73	4409	1270	5.00	4660	1317	5.36	4996
5400	968	3.31	3083	1035	3.54	3298	1083	3.85	3587	1120	4.03	3753	1160	4.33	4032	1202	4.54	4231	1233	4.68	4363	1262	4.91	4580	1278	5.20	4848	---	---	---
5500	984	3.48	3240	1052	3.71	3455	1098	4.01	3740	1135	4.20	3918	1174	4.51	4200	1215	4.72	4396	1244	4.86	4528	1273	5.10	4757	1286	5.41	5044	---	---	---
5600	1001	3.65	3403	1069	3.88	3618	1113	4.18	3897	1149	4.39	4089	1188	4.69	4372	1228	4.90	4566	1256	5.04	4698	1283	5.30	4938	---	---	---	---	---	
5700	1017	3.83	3574	1085	4.06	3788	1128	4.35	4058	1164	4.58	4265	1201	4.88	4549	1241	5.08	4740	1267	5.23	4872	1293	5.50	5125	---	---	---	---	---	
5800	1033	4.02	3751	1102	4.25	3965	1143	4.53	4224	1178	4.77	4447	1215	5.07	4731	1254	5.28	4918	1279	5.42	5050	---	---	---	---	---	---	---	---	
5900	1050	4.22	3936	1119	4.45	4149	1159	4.71	4393	1193	4.97	4635	1229	5.27	4917	1267	5.47	5101	---	---	---	---	---	---	---	---	---	---	---	---
6000	1066	4.43	4127	1136	4.66	4341	1174	4.90	4567	1207	5.18	4828	1243	5.48	5108	---	---	---	---	---	---	---	---	---	---	---	---	---	---	---
6100	1082	4.64	4326	1152	4.87	4539	1189	5.09	4745	1222	5.39	5027	---	---	---	---	---	---	---	---	---	---	---	---	---	---	---	---	---	---
6200	1098	4.86	4531	1169	5.09	4744	1204	5.29	4927	1236	5.61	5231	---	---	---	---	---	---	---	---	---	---	---	---	---	---	---	---	---	---

High Horsepower Option Required

TABLE 26: DH078 (6-1/2 TON) DOWN SHOT BLOWER PERFORMANCE

CFM	External Static Pressure																							
	0.2		0.4		0.6		0.8		1.0		1.2		1.4		1.6									
	RPM	BHP	Watts	RPM	BHP	Watts	RPM	BHP	Watts	RPM	BHP	Watts	RPM	BHP	Watts	RPM	BHP	Watts						
1800	770	0.49	456	835	0.62	576	907	0.75	694	983	0.87	810	1058	0.99	920	1127	1.10	1024	1186	1.20	1120	1229	1.29	1206
1900	783	0.54	505	848	0.67	625	920	0.80	743	996	0.92	859	1071	1.04	969	1140	1.15	1073	1199	1.25	1168	1242	1.35	1255
2000	798	0.60	558	862	0.73	678	935	0.85	796	1011	0.98	911	1086	1.10	1022	1155	1.21	1125	1213	1.31	1221	1257	1.40	1307
2100	814	0.66	614	878	0.79	734	951	0.91	853	1027	1.04	968	1102	1.16	1078	1171	1.27	1182	1229	1.37	1278	1273	1.46	1364
2200	831	0.72	674	895	0.85	794	968	0.98	913	1044	1.10	1028	1119	1.22	1138	1188	1.33	1242	1247	1.44	1338	1290	1.53	1424
2300	850	0.79	738	914	0.92	858	986	1.05	976	1062	1.17	1091	1137	1.29	1202	1206	1.40	1306	1265	1.50	1401	1308	1.60	1487
2400	869	0.86	805	933	0.99	925	1005	1.12	1043	1081	1.24	1158	1156	1.36	1268	1225	1.47	1372	1284	1.57	1468	1328	1.67	1554
2500	889	0.94	874	953	1.07	994	1025	1.19	1113	1101	1.32	1228	1176	1.44	1338	1245	1.55	1442	1304	1.65	1538	1412	1.95	1817
2600	909	1.02	947	973	1.14	1067	1046	1.27	1186	1122	1.40	1301	1197	1.51	1411	1266	1.63	1515	1324	1.73	1611	1434	2.05	1913
2700	930	1.10	1023	994	1.23	1143	1067	1.35	1261	1143	1.48	1377	1218	1.60	1487	1287	1.71	1591	1389	2.09	1946	1457	2.16	2015
2800	952	1.18	1102	1016	1.31	1221	1088	1.44	1340	1164	1.56	1455	1239	1.68	1565	1344	2.10	1957	1414	2.20	2053	1482	2.28	2121
2900	974	1.27	1183	1038	1.40	1303	1110	1.52	1421	1186	1.65	1536	1299	2.09	1949	1370	2.22	2068	*****	*****	*****	*****	*****	*****
3000	996	1.36	1266	1060	1.49	1386	1133	1.61	1505	1254	2.06	1923	1326	2.21	2064	*****	*****	*****	*****	*****	*****	*****	*****	*****
3100	1019	1.45	1353	1083	1.58	1473	1155	1.71	1591	1281	2.19	2043	*****	*****	*****	*****	*****	*****	*****	*****	*****	*****	*****	*****
3200	1042	1.55	1441	1106	1.67	1561	1237	2.15	2007	*****	*****	*****	*****	*****	*****	*****	*****	*****	*****	*****	*****	*****	*****	*****
3300	1065	1.64	1532	1192	2.10	1959	1266	2.29	2136	*****	*****	*****	*****	*****	*****	*****	*****	*****	*****	*****	*****	*****	*****	*****
3400	1148	2.04	1902	1223	2.24	2092	*****	*****	*****	*****	*****	*****	*****	*****	*****	*****	*****	*****	*****	*****	*****	*****	*****	*****
3500	1179	2.19	2039	1254	2.39	2230	*****	*****	*****	*****	*****	*****	*****	*****	*****	*****	*****	*****	*****	*****	*****	*****	*****	*****

High Horsepower Option Required

TABLE 27: DH090 (7-1/2 TON) DOWN SHOT BLOWER PERFORMANCE

CFM	External Static Pressure																										
	0.2			0.4			0.6			0.8			1.0			1.2			1.4			1.6			1.8		
	RPM	BHP	Watts	RPM	BHP	Watts	RPM	BHP	Watts	RPM	BHP	Watts	RPM	BHP	Watts	RPM	BHP	Watts	RPM	BHP	Watts	RPM	BHP	Watts	RPM	BHP	Watts
2000	814	0.52	488	888	0.71	665	960	0.89	834	1030	1.06	984	1103	1.18	1104	1179	1.27	1185	1253	1.51	1411	1335	1.69	1577	1429	1.90	1773
2100	831	0.60	558	905	0.79	735	977	0.97	904	1047	1.13	1054	1120	1.26	1174	1196	1.35	1255	1266	1.60	1492	1349	1.78	1658	1443	1.99	1854
2200	849	0.68	633	924	0.87	810	995	1.05	979	1066	1.21	1129	1138	1.34	1249	1214	1.43	1330	1282	1.69	1574	1364	1.87	1741	1458	2.08	1936
2300	869	0.77	713	943	0.95	890	1015	1.14	1059	1086	1.30	1208	1158	1.43	1329	1234	1.51	1410	1299	1.78	1658	1381	1.96	1824	1475	2.17	2020
2400	890	0.86	798	964	1.05	975	1036	1.23	1143	1106	1.39	1293	1179	1.52	1414	1255	1.60	1495	1317	1.87	1745	1400	2.05	1911	1493	2.26	2107
2500	911	0.95	887	986	1.14	1063	1057	1.32	1232	1128	1.48	1382	1201	1.61	1503	1277	1.70	1584	1337	1.97	1834	1420	2.15	2000	1513	2.36	2196
2600	934	1.05	980	1009	1.24	1157	1080	1.42	1325	1151	1.58	1475	1223	1.71	1596	1299	1.80	1677	1358	2.07	1928	1440	2.25	2094	1534	2.46	2290
2700	958	1.16	1077	1032	1.35	1254	1104	1.53	1422	1175	1.69	1572	1247	1.82	1693	1323	1.90	1774	1379	2.17	2026	1462	2.35	2192	1556	2.56	2388
2800	982	1.26	1178	1057	1.45	1355	1128	1.63	1524	1199	1.80	1674	1271	1.92	1794	1348	2.01	1875	1402	2.28	2128	1485	2.46	2294	1578	2.67	2490
2900	1007	1.38	1283	1082	1.57	1460	1153	1.75	1629	1224	1.91	1779	1297	2.04	1899	1373	2.12	1980	1425	2.40	2236	1508	2.58	2402	1602	2.79	2598
3000	1033	1.49	1392	1108	1.68	1569	1179	1.86	1737	1250	2.02	1887	1322	2.15	2008	1399	2.24	2089	1450	2.52	2348	1532	2.70	2515	1626	2.91	2710
3100	1060	1.61	1504	1134	1.80	1681	1206	1.98	1850	1277	2.15	1999	1349	2.27	2120	1400	2.49	2319	1474	2.65	2467	1557	2.82	2633	1651	3.03	2829
3200	1087	1.74	1620	1162	1.93	1797	1233	2.11	1965	1304	2.27	2115	1357	2.47	2303	1426	2.62	2443	1500	2.78	2590	1583	2.96	2756	1676	3.17	2952
3300	1115	1.87	1739	1189	2.06	1916	1261	2.24	2084	1318	2.46	2291	1383	2.61	2433	1451	2.76	2572	1526	2.92	2719	1608	3.10	2886	1702	3.31	3081
3400	1143	2.00	1861	1218	2.19	2038	1279	2.44	2270	1344	2.60	2426	1409	2.75	2568	1478	2.90	2707	1552	3.06	2854	1635	3.24	3021	1729	3.45	3216
3500	1172	2.13	1986	1246	2.32	2163	1306	2.59	2411	1371	2.75	2566	1436	2.91	2708	1505	3.06	2848	1579	3.21	2995	1662	3.39	3161	1779	3.66	3416
3600	1201	2.27	2114	1267	2.55	2377	1334	2.74	2557	1398	2.91	2713	1464	3.06	2855	1532	3.21	2994	1606	3.37	3142	1695	3.56	3296	1829	3.93	4096
3700	1223	2.48	2314	1295	2.71	2530	1361	2.91	2710	1426	3.07	2865	1491	3.23	3007	1560	3.38	3147	1647	3.52	3288	1741	3.71	3433	1881	4.08	4481
3800	1251	2.65	2473	1323	2.88	2688	1389	3.08	2868	1454	3.24	3023	1519	3.40	3165	1600	3.56	3307	1695	3.71	3481	1801	3.90	3631	1951	4.28	4881
3900	1280	2.83	2636	1351	3.06	2852	1418	3.25	3032	1487	3.46	3133	1551	3.57	3277	1650	3.71	3411	1741	3.86	3631	1881	4.05	3781	2001	4.45	5281
4000	1308	3.01	2806	1380	3.24	3021	1446	3.43	3201	1519	3.66	3277	1600	3.78	3411	1700	3.90	3551	1800	4.05	3781	1951	4.24	3931	2051	4.63	5781

High Horsepower Option Required

TABLE 28: DH102 (8-1/2 TON) DOWN SHOT BLOWER PERFORMANCE

CFM	External Static Pressure																										
	0.2			0.4			0.6			0.8			1.0			1.2			1.4			1.6			1.8		
	RPM	BHP	Watts	RPM	BHP	Watts	RPM	BHP	Watts	RPM	BHP	Watts	RPM	BHP	Watts	RPM	BHP	Watts	RPM	BHP	Watts	RPM	BHP	Watts	RPM	BHP	Watts
2000	842	0.46	431	913	0.69	647	980	0.89	827	1044	1.05	982	1110	1.21	1124	1178	1.36	1263	1253	1.51	1411	1335	1.69	1577	1429	1.90	1773
2100	856	0.55	513	927	0.78	728	993	0.97	908	1058	1.14	1064	1123	1.29	1206	1192	1.44	1345	1266	1.60	1492	1349	1.78	1658	1443	1.99	1854
2200	871	0.64	595	942	0.87	810	1009	1.06	990	1074	1.23	1146	1139	1.38	1288	1207	1.53	1427	1282	1.69	1574	1364	1.87	1741	1458	2.08	1936
2300	888	0.73	679	959	0.96	894	1026	1.15	1074	1091	1.32	1230	1156	1.47	1372	1224	1.62	1511	1299	1.78	1658	1381	1.96	1824	1475	2.17	2020
2400	906	0.82	765	978	1.05	980	1044	1.24	1160	1109	1.41	1316	1174	1.56	1458	1243	1.71	1597	1317	1.87	1745	1400	2.05	1911	1493	2.26	2107
2500	926	0.92	855	997	1.15	1070	1064	1.34	1250	1129	1.51	1406	1194	1.66	1548	1262	1.81	1687	1340	2.02	1883	1415	2.13	1990	1494	2.21	2063
2600	947	1.02	948	1018	1.25	1164	1085	1.44	1344	1149	1.61	1499	1215	1.76	1641	1283	1.91	1780	1362	2.13	1990	1436	2.25	2096	1515	2.33	2170
2700	969	1.12	1046	1040	1.35	1261	1106	1.55	1441	1171	1.71	1597	1236	1.87	1739	1305	2.02	1878	1384	2.26	2102	1459	2.37	2209	1538	2.45	2282
2800	991	1.23	1149	1062	1.46	1364	1129	1.66	1544	1194	1.82	1700	1259	1.98	1842	1328	2.13	1981	1408	2.38	2221	1483	2.50	2328	1562	2.58	2401
2900	1015	1.35	1256	1086	1.58	1471	1152	1.77	1651	1217	1.94	1807	1283	2.09	1949	1362	2.37	2207	1434	2.52	2346	1508	2.63	2452	1587	2.71	2526
3000	1039	1.47	1369	1110	1.70	1584	1177	1.89	1764	1241	2.06	1920	1307	2.21	2062	1388	2.51	2338	1460	2.66	2477	1534	2.77	2583	1613	2.85	2657
3100	1064	1.60	1487	1135	1.83	1702	1201	2.02	1882	1266	2.19	2038	1345	2.47	2307	1415	2.66	2475	1487	2.80	2614	1561	2.92	2721	1641	3.00	2794
3200	1089	1.73	1611	1160	1.96	1826	1227	2.15	2006	1292	2.32	2161	1373	2.63	2450	1443	2.81	2619	1515	2.96	2757	1590	3.07	2864	1669	3.15	2937
3300	1115	1.87	1740	1186	2.10	1955	1253	2.29	2135	1318	2.46	2291	1402	2.79	2600	1472	2.97	2768	1544	3.12	2907	1619	3.23	3013	1698	3.31	3087
3400	1142	2.01	1875	1213	2.24	2090	1279	2.44	2270	1361	2.74	2558	1432	2.96	2755	1502	3.14	2924	1574	3.29	3062	1648	3.40	3169	1777	3.50	3262
3500	1168	2.16	2016	1240	2.39	2231	1306	2.59	2411	1392	2.92	2720	1462	3.13	2917	1533	3.31	3086	1648	3.40	3169	1777	3.50	3262	1888	3.61	3381
3600	1196	2.32	2162	1267	2.55	2377	1351	2.86	2663	1423	3.10	2887	1494	3.31	3085	1648	3.40	3169	1777	3.50	3262	1888	3.61	3381	1999	3.72	3506
3700	1223	2.48	2314	1295	2.71	2530	1383	3.04	2837	1455	3.28	3061	1544	3.40	3169	1777	3.50	3262	1888	3.61	3381	1999	3.72	3506	2110	3.83	3631
3800	1251	2.65	2473	1341	2.97	2767	1416	3.24	3016	1506	3.40	3169	1648	3.40	3169	1777	3.50	3262	1888	3.61	3381	1999	3.72	3506	2221	3.94	3756
3900	1280	2.83	2636	1374	3.17	2952	1450	3.43	3202	1557	3.50	3262	1648	3.40	3169	1777	3.50	3262	1888	3.61	3381	1999	3.72	3506	2332	4.05	3881
4000	1328	3.08	2870	1408	3.37	3143	1483	3.61	3381	1607	3.61	3381	1648	3.40	3169	1777	3.50	3262	1888	3.61	3381	1999	3.72	3506	2443	4.16	4006
4100	1363	3.29	3067	1443	3.56	3334	1516	3.79	3506	1658	3.61	3381	1648	3.40	3169	1777	3.50	3262	1888	3.61	3381	1999	3.72	3506	2554	4.27	4131

Optional Drive Required

TABLE 29: DH120 (10 TON) DOWN SHOT BLOWER PERFORMANCE

CFM	External Static Pressure																							
	0.2		0.4		0.6		0.8		1.0		1.2		1.4		1.6									
	RPM	BHP	Watts	RPM	BHP	Watts	RPM	BHP	Watts	RPM	BHP	Watts	RPM	BHP	Watts	RPM	BHP	Watts						
3000	----	----	----	741	1.21	1128	814	1.34	1248	880	1.50	1400	935	1.68	1564	981	1.86	1732	1018	2.03	1893	1047	2.17	2026
3100	----	----	----	758	1.26	1178	829	1.41	1312	892	1.58	1473	945	1.76	1643	990	1.95	1815	1025	2.12	1976	1053	2.26	2107
3200	----	----	----	775	1.32	1234	843	1.48	1381	904	1.66	1550	956	1.85	1726	998	2.04	1900	1032	2.21	2061	1060	2.35	2190
3300	----	----	----	792	1.39	1298	858	1.56	1456	916	1.75	1632	966	1.94	1812	1007	2.13	1989	1040	2.31	2149	1066	2.44	2275
3400	1.34	1248	809	1.47	1369	872	1.65	1537	929	1.84	1719	976	2.04	1902	1015	2.23	2080	1047	2.40	2239	1072	2.53	2361	
3500	767	1.41	1315	826	1.55	1447	887	1.74	1623	941	1.94	1810	986	2.14	1995	1024	2.33	2174	1054	2.50	2331	-----	-----	-----
3600	786	1.49	1391	843	1.64	1532	901	1.84	1715	953	2.04	1905	997	2.24	2092	1033	2.44	2270	1062	2.60	2425	-----	-----	-----
3700	805	1.58	1474	860	1.74	1624	916	1.94	1812	965	2.15	2005	1007	2.35	2193	1041	2.54	2370	1069	2.71	2522	-----	-----	-----
3800	824	1.68	1566	877	1.85	1723	930	2.05	1915	977	2.26	2109	1017	2.46	2297	1050	2.65	2473	1076	2.81	2621	-----	-----	-----
3900	843	1.79	1666	894	1.96	1829	945	2.17	2023	990	2.38	2218	1027	2.58	2405	1059	2.77	2578	-----	-----	-----	-----	-----	-----
4000	862	1.90	1774	911	2.08	1943	959	2.29	2138	1002	2.50	2331	1038	2.70	2516	1067	2.88	2686	-----	-----	-----	-----	-----	-----
4100	881	2.03	1890	928	2.21	2063	974	2.42	2257	1014	2.63	2449	1048	2.82	2631	1076	3.00	2797	-----	-----	-----	-----	-----	-----
4200	900	2.16	2015	945	2.35	2190	988	2.56	2383	1026	2.76	2571	1058	2.95	2749	-----	-----	-----	-----	-----	-----	-----	-----	-----
4300	919	2.30	2148	962	2.49	2324	1003	2.70	2514	1038	2.89	2697	1068	3.08	2871	-----	-----	-----	-----	-----	-----	-----	-----	-----
4400	938	2.45	2288	979	2.65	2466	1017	2.84	2650	1050	3.03	2828	1079	3.21	2996	-----	-----	-----	-----	-----	-----	-----	-----	-----
4500	957	2.61	2437	996	2.80	2614	1032	3.00	2792	1063	3.18	2963	-----	-----	-----	-----	-----	-----	-----	-----	-----	-----	-----	-----
4600	976	2.78	2595	1013	2.97	2770	1046	3.15	2940	1075	3.33	3103	-----	-----	-----	-----	-----	-----	-----	-----	-----	-----	-----	-----
4700	995	2.96	2760	1030	3.15	2932	1061	3.32	3094	-----	-----	-----	-----	-----	-----	-----	-----	-----	-----	-----	-----	-----	-----	-----
4800	1015	3.15	2934	1047	3.33	3102	1075	3.49	3253	-----	-----	-----	-----	-----	-----	-----	-----	-----	-----	-----	-----	-----	-----	-----
4900	1034	3.34	3115	1065	3.52	3278	-----	-----	-----	-----	-----	-----	-----	-----	-----	-----	-----	-----	-----	-----	-----	-----	-----	-----
5000	1053	3.55	3305	1082	3.71	3462	-----	-----	-----	-----	-----	-----	-----	-----	-----	-----	-----	-----	-----	-----	-----	-----	-----	-----

High Horsepower Option Required

Motor Efficiency 0.8

Std HP Motor2

TABLE 30: DH150 (12-1/2 TON) DOWN SHOT BLOWER PERFORMANCE

CFM	External Static Pressure																																			
	0.2		0.4		0.6		0.8		1.0		1.2		1.4		1.6		1.8		2.0																	
	RPM	BHP	Watts	RPM	BHP	Watts	RPM	BHP	Watts	RPM	BHP	Watts	RPM	BHP	Watts	RPM	BHP	Watts	RPM	BHP	Watts															
3700	---	---	---	---	---	---	908	1.99	1853	1004	2.27	2112	1050	2.42	2258	1094	2.59	2412	1136	2.76	2571	1177	2.93	2733	1217	3.11	2895									
3800	---	---	---	875	1.96	1831	926	2.09	1946	974	2.23	2077	1020	2.38	2220	1065	2.54	2372	1108	2.71	2530	1151	2.89	2693	1191	3.06	2856	1231	3.24	3021						
3900	---	---	---	---	---	---	893	2.06	1918	943	2.19	2044	990	2.34	2183	1036	2.50	2332	1080	2.67	2489	1123	2.84	2652	1165	3.02	2817	1205	3.20	2983	1244	3.38	3149			
4000	---	---	---	---	---	---	911	2.16	2012	960	2.30	2147	1007	2.46	2294	1052	2.63	2449	1096	2.80	2611	1138	2.98	2777	1179	3.16	2945	1219	3.34	3113	1258	3.52	3280			
4100	878	2.13	1984	929	2.27	2113	977	2.42	2256	1023	2.59	2410	1068	2.76	2571	1111	2.94	2737	1153	3.12	2906	1194	3.30	3076	1233	3.48	3245	1271	3.66	3414						
4200	897	2.23	2080	947	2.38	2219	995	2.54	2371	1040	2.72	2531	1084	2.89	2697	1127	3.08	2867	1168	3.26	3039	1208	3.44	3211	1247	3.63	3381	1285	3.81	3550						
4300	915	2.34	2184	965	2.50	2332	1012	2.67	2491	1056	2.85	2657	1100	3.03	2828	1142	3.22	3001	1183	3.41	3175	1223	3.59	3348	1261	3.78	3520	1298	3.96	3690						
4400	934	2.46	2294	983	2.63	2451	1029	2.81	2617	1073	2.99	2788	1116	3.18	2963	1157	3.37	3139	1198	3.56	3315	1237	3.74	3490	1275	3.93	3662	1311	4.11	3832						
4500	953	2.59	2411	1001	2.76	2577	1046	2.95	2749	1090	3.14	2925	1132	3.33	3103	1173	3.52	3281	1212	3.71	3459	1251	3.90	3634	1289	4.08	3807	1325	4.27	3977						
4600	972	2.72	2536	1019	2.91	2708	1063	3.10	2886	1106	3.29	3066	1148	3.48	3247	1188	3.68	3428	1227	3.87	3606	1266	4.06	3782	1303	4.24	3955	1338	4.43	4125						
4700	991	2.86	2667	1036	3.05	2846	1081	3.25	3029	1123	3.45	3212	1164	3.64	3396	1204	3.84	3578	1242	4.03	3758	1280	4.22	3933	1316	4.40	4106	1352	4.59	4275						
4800	1009	3.01	2806	1054	3.21	2990	1098	3.41	3177	1139	3.61	3364	1180	3.81	3549	1219	4.00	3732	1257	4.20	3912	1294	4.39	4088	1330	4.57	4260	1365	4.75	4429						
4900	1028	3.17	2951	1072	3.37	3141	1115	3.57	3331	1156	3.78	3520	1196	3.98	3707	1234	4.17	3891	1272	4.37	4071	1309	4.56	4246	1344	4.74	4417	1379	4.92	4585						
5000	1047	3.33	3103	1090	3.54	3297	1132	3.74	3491	1172	3.95	3682	1211	4.15	3870	1250	4.35	4054	1287	4.54	4233	1323	4.73	4407	1358	4.91	4577	1392	5.09	4744						
5100	1066	3.50	3263	1108	3.71	3460	1149	3.92	3656	1189	4.13	3848	1227	4.33	4037	1265	4.53	4221	1302	4.72	4399	1338	4.91	4572	1372	5.09	4740	---	---	---	---					
5200	1084	3.68	3430	1126	3.89	3629	1167	4.11	3827	1205	4.31	4020	1243	4.51	4208	1281	4.71	4391	1317	4.90	4569	1352	5.09	4740	---	---	---	---	---	---	---					
5300	1103	3.87	3603	1144	4.08	3805	1184	4.29	4003	1222	4.50	4196	1259	4.70	4384	1296	4.90	4566	1331	5.09	4742	---	---	---	---	---	---	---	---	---	---					
5400	1122	4.06	3784	1162	4.28	3987	1201	4.49	4185	1238	4.70	4378	1275	4.90	4565	1311	5.09	4745	---	---	---	---	---	---	---	---	---	---	---	---	---	---				
5500	1141	4.26	3971	1180	4.48	4175	1218	4.69	4373	1255	4.90	4564	1291	5.10	4750	---	---	---	---	---	---	---	---	---	---	---	---	---	---	---	---	---				
5600	1160	4.47	4166	1198	4.69	4369	1235	4.90	4566	1271	5.10	4756	---	---	---	---	---	---	---	---	---	---	---	---	---	---	---	---	---	---	---	---	---			
5700	1178	4.69	4368	1216	4.90	4569	1253	5.11	4765	---	---	---	---	---	---	---	---	---	---	---	---	---	---	---	---	---	---	---	---	---	---	---	---			
5800	1197	4.91	4576	1234	5.12	4776	---	---	---	---	---	---	---	---	---	---	---	---	---	---	---	---	---	---	---	---	---	---	---	---	---	---	---			
5900	1216	5.14	4792	---	---	---	---	---	---	---	---	---	---	---	---	---	---	---	---	---	---	---	---	---	---	---	---	---	---	---	---	---	---	---		
6000	---	---	---	---	---	---	---	---	---	---	---	---	---	---	---	---	---	---	---	---	---	---	---	---	---	---	---	---	---	---	---	---	---	---	---	
6100	---	---	---	---	---	---	---	---	---	---	---	---	---	---	---	---	---	---	---	---	---	---	---	---	---	---	---	---	---	---	---	---	---	---	---	
6200	---	---	---	---	---	---	---	---	---	---	---	---	---	---	---	---	---	---	---	---	---	---	---	---	---	---	---	---	---	---	---	---	---	---	---	---

High Horsepower Option Required

Motor Efficiency 0.8

Std HP Motor 3

TABLE 31: ADDITIONAL STATIC RESISTANCE DH120 AND 150

CFM	Cooling Only ¹	Economizer ^{2 3}	Electric Heat KW ²				
			9	18	24	36	54
1900	0.06	0.02	0.05	0.06	0.07	0.08	0.10
2100	0.07	0.02	0.06	0.07	0.08	0.09	0.11
2300	0.08	0.02	0.07	0.08	0.09	0.10	0.13
2500	0.09	0.02	0.08	0.09	0.10	0.11	0.14
2700	0.11	0.03	0.09	0.10	0.12	0.13	0.16
2900	0.12	0.03	0.10	0.11	0.13	0.14	0.18
3100	0.14	0.03	0.12	0.13	0.15	0.16	0.20
3300	0.16	0.03	0.13	0.14	0.17	0.18	0.22
3500	0.18	0.04	0.15	0.16	0.19	0.20	0.24
3700	0.20	0.04	0.17	0.18	0.21	0.22	0.26
3900	0.23	0.04	0.19	0.20	0.23	0.24	0.28
4100	0.25	0.04	0.21	0.22	0.25	0.26	0.31
4300	0.28	0.05	0.23	0.24	0.28	0.29	0.34
4500	0.30	0.05	0.25	0.26	0.30	0.31	0.37
4700	0.33	0.05	0.28	0.29	0.33	0.34	0.40
4900	0.36	0.05	0.30	0.31	0.35	0.37	0.43
5100	0.39	0.06	0.33	0.34	0.38	0.40	0.46
5300	0.42	0.06	0.35	0.37	0.41	0.43	0.49
5500	0.45	0.06	0.38	0.40	0.44	0.46	0.53
5700	0.48	0.06	0.41	0.43	0.47	0.49	0.56
5900	0.52	0.07	0.44	0.46	0.50	0.53	0.59
6100	0.56	0.07	0.47	0.49	0.53	0.56	0.62
6300	0.60	0.07	0.50	0.53	0.56	0.59	0.65

- 1 Add these resistance values to the available static resistance in the respective Blower Performance Tables.
- 2 Deduct these resistance values from the available external static pressure shown in the respective Blower Performance Table.
- 3 The pressure drop through the economizer is greater for 100% outdoor air than for 100% return air. If the resistance of the return air duct system is less than 0.25 IWG, the unit will deliver less CFM during full economizer operation.

TABLE 32: ADDITIONAL STATIC RESISTANCE DH078, 090, 102

CFM	Cooling Only ¹	Economizer ^{2 3}	Electric Heat KW ²				
			9	18	24	36	54
1900	-0.004	0.07	0.05	0.06	0.07	0.08	0.10
2100	0.01	0.09	0.06	0.07	0.08	0.09	0.11
2300	0.01	0.11	0.07	0.08	0.09	0.10	0.13
2500	0.02	0.13	0.08	0.09	0.10	0.11	0.14
2700	0.03	0.16	0.09	0.10	0.12	0.13	0.16
2900	0.04	0.18	0.10	0.11	0.13	0.14	0.18
3100	0.05	0.20	0.12	0.13	0.15	0.16	0.20
3300	0.06	0.22	0.13	0.14	0.17	0.18	0.22
3500	0.07	0.24	0.15	0.16	0.19	0.20	0.24
3700	0.08	0.27	0.17	0.18	0.21	0.22	0.26
3900	0.09	0.29	0.19	0.20	0.23	0.24	0.28
4100	0.09	0.31	0.21	0.22	0.25	0.26	0.31
4300	0.10	0.33	0.23	0.24	0.28	0.29	0.34

- 1 Deduct these resistance values to the available static resistance in the respective Blower Performance Tables.
- 2 Deduct these resistance values from the available external static pressure shown in the respective Blower Performance Table.
- 3 The pressure drop through the economizer is greater for 100% outdoor air than for 100% return air. If the resistance of the return air duct system is less than 0.25 IWG, the unit will deliver less CFM during full economizer operation.

TABLE 33: ELECTRIC HEAT MINIMUM SUPPLY AIR CFM

HEATER		UNIT MODEL SIZE (NOMINAL TONS)				
kW	VOLTAGE	078 (6.5)	090 (7.5)	102 (8.5)	120 (10)	150 (12.5)
		MINIMUM SUPPLY AIR CFM				
9	208/230	1950	2250	2550	-	-
18		1950	2250	2550	3000	3750
24		1950	2250	2550	3000	3750
36		1950	2250	2550	3000	3750
54		-	-	-	3500	4000
9	480	1950	2250	2550	-	-
18		1950	2250	2550	3000	3750
24		1950	2250	2550	3000	3750
36		1950	2250	2550	3000	3750
54		-	-	-	3000	3750
9	600	1950	2250	2550	-	-
18		1950	2250	2550	3000	3750
24		1950	2250	2550	3000	3750
36		1950	2250	2550	3000	3750
54		-	-	-	3500	3750

TABLE 34: INDOOR BLOWER SPECIFICATIONS

MODEL	MOTOR					MOTOR SHEAVE			BLOWER SHEAVE			BELT
	HP	RPM	Eff.	SF	Frame	Datum Dia. (in.)	Bore (in.)	Model	Datum Dia. (in.)	Bore (in.)	Model	
DH078	1-1/2	1725	80%	1.15	56	3.4 - 4.4	7/8	1VM50	7.0	1	AK74	A49
	2	1725	80%	1.15	56	3.4 - 4.4	7/8	1VM50	6.2	1	AK66	A49
DH090	2	1725	80%	1.15	56	3.4 - 4.4	7/8	1VM50	6.5	1	AK69	A49
	3	1725	80%	1.15	56	3.4 - 4.4	7/8	1VM50	6.0	1	AK64	A49
DH102	3	1725	80%	1.15	56	3.4 - 4.4	7/8	1VM50	6.0	1	AK64	A49
	3	1725	80%	1.15	56	3.4 - 4.4	7/8	1VM50	5.7	1	AK61	A49
DH120	2	1725	80%	1.15	56	3.4 - 4.4	7/8	1VM50	8.5	1	AK89	A56
	3	1725	80%	1.15	56	3.4 - 4.4	7/8	1VM50	7.0	1	AK74	A54
DH150	3	1725	80%	1.15	56	3.4 - 4.4	7/8	1VM50	7.0	1	AK74	A54
	5	1725	87%	1.15	184T	4.3 - 5.3	1 1/8	1VP56	6.7	1	BK77	BX55

TABLE 35: POWER EXHAUST SPECIFICATIONS

POWER EXHAUST MODEL	VOLT	PHASE	MOTOR			ELECTRICAL			FUSE SIZE	CFM@ 0.1 ESP
			HP	RPM ¹	QTY	LRA	FLA	MCA		
2PE0473225	208/230	1	0.75	1075	1	24.9	5.0	6.3	10	3,800
2PE0473246	460	1				-	2.2	2.8	5	
2PE0473258	575	1				-	1.5	1.9	4	

1 Motors are multi-tapped and factory wired for high speed.

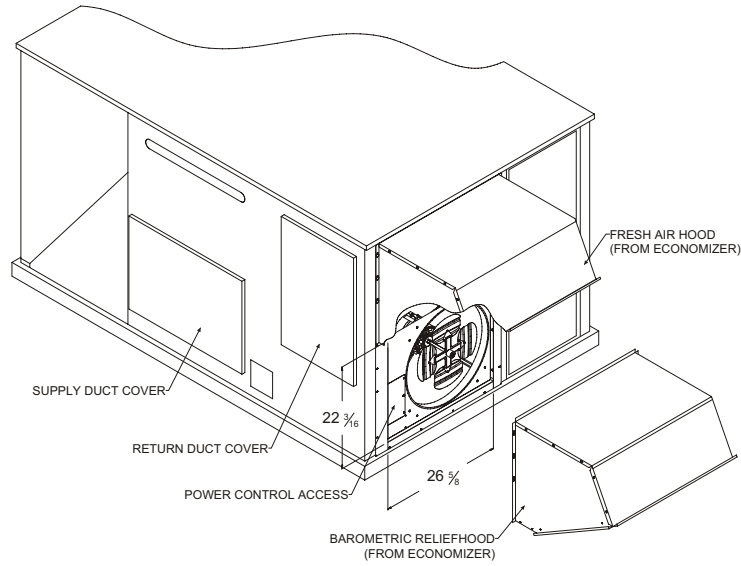

FIGURE 2 - POWER EXHAUST ACCESSORY DOWNFLOW APPLICATION

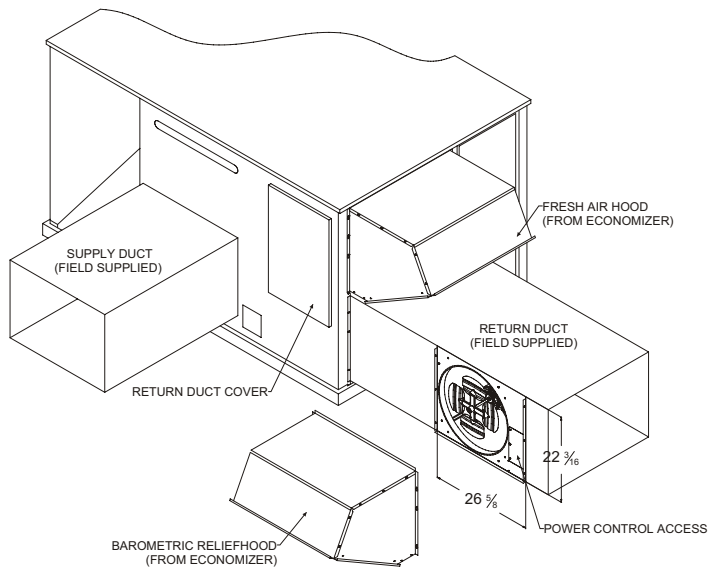

FIGURE 3 - POWER EXHAUST ACCESSORY HORIZONTAL APPLICATION

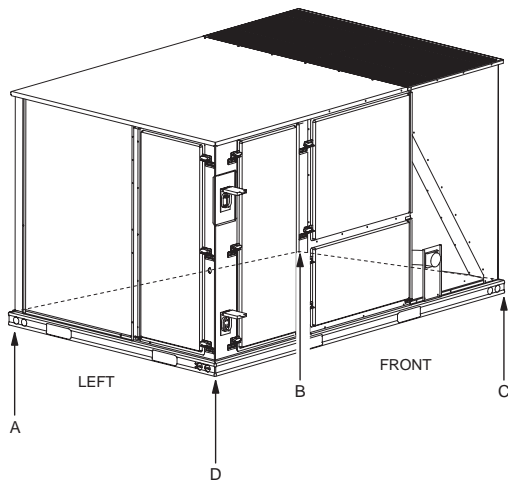

FIGURE 4 - UNIT 4 POINT LOAD

TABLE 36: 4 POINT LOAD WEIGHT

Model	Location (lbs.)			
	A	B	C	D
DH078	197	147	230	309
DH090	199	148	232	311
DH102	201	150	234	315
DH120	265	226	330	386
DH150	263	224	327	383

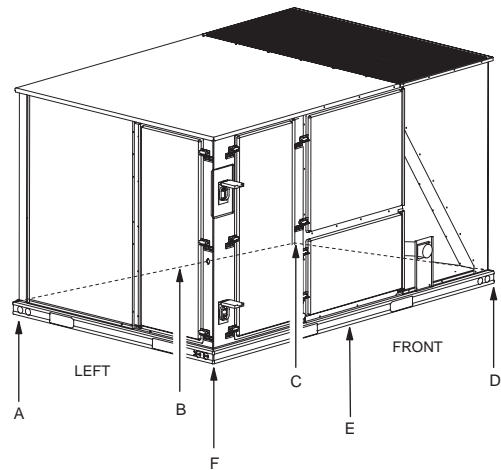
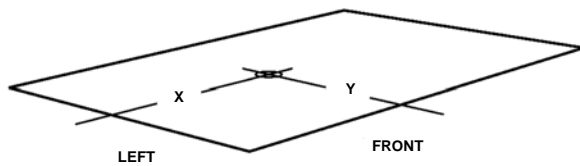

FIGURE 6 - UNIT 6 POINT LOAD

TABLE 37: 6 POINT LOAD WEIGHT

Model	Locations (lbs.)					
	A	B	C	D	E	F
DH078	138	113	93	146	176	216
DH090	139	113	94	147	178	218
DH102	141	115	95	149	180	221
DH120	181	163	147	214	237	264
DH150	180	161	146	213	235	262



Unit Model Number	X	Y
DH078	38	23
DH090	38	23
DH102	38	23
DH120	47 1/2	25 1/2
DH150	47 1/2	25 1/2

FIGURE 5 - UNIT CENTER OF GRAVITY

TABLE 38: UNIT WEIGHT

Model	Shipping Weight (lbs.)	Operating Weight (lbs.)
DH078	888	883
DH090	895	890
DH102	905	900
DH120	1212	1207
DH150	1202	1197
W/ECON.	85	84
W/PE	150	148
W/ELECT. HEAT ¹	49	49
W/GAS HEAT ²	110	110

- 1 54 KW Heater
- 2 8 Tube Heat Exchanger

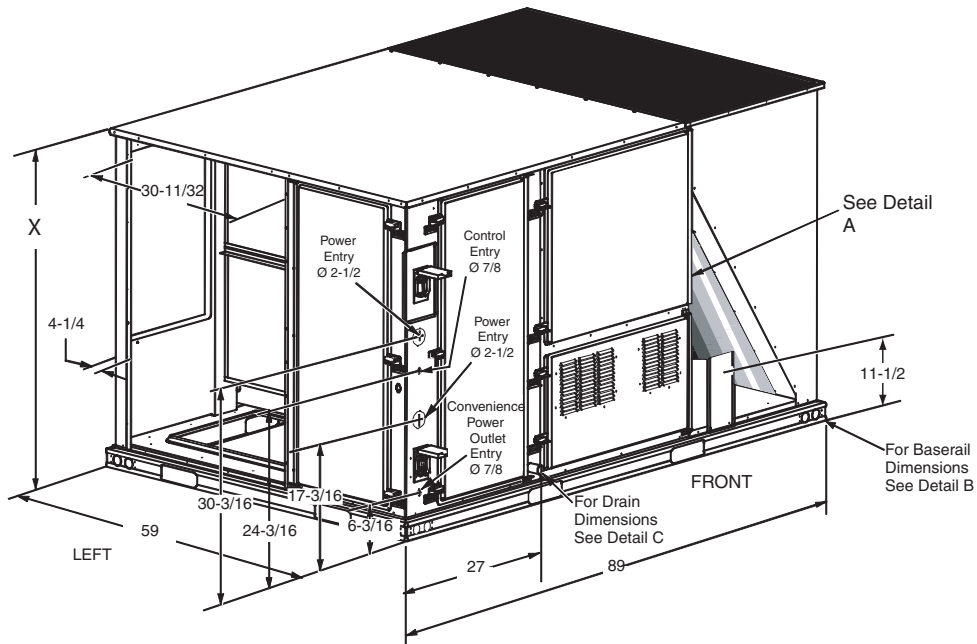
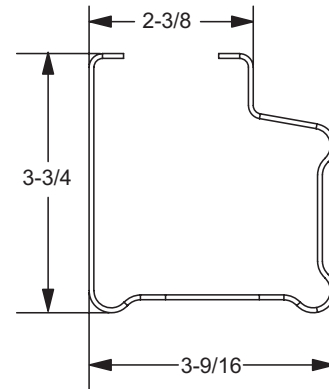

FIGURE 7 - UNIT DIMENSIONS

TABLE 39: UNIT HEIGHT

Unit Model Number	X
DH078	42
DH090	42
DH102	42
DH120	50 3/4
DH150	50 3/4

DETAIL B



DETAIL A

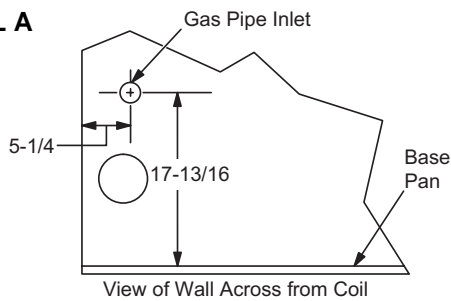

DETAIL C

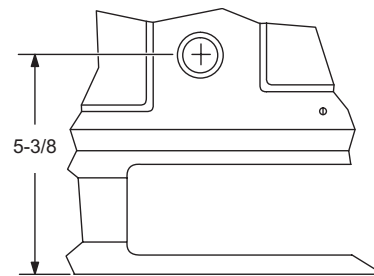

TABLE 40: UNIT CLEARANCES

Top ¹	72"	Right	12"
Front	36"	Left	36"
Rear ²	36"	Bottom ³	0"

- Units must be installed outdoors. Overhanging structure or shrubs should not obstruct condenser air discharge outlet.
- To remove the slide-out drain pan, a rear clearance of 60" is required. If space is unavailable, the drain pan can be removed through the front by separating the corner wall.
- Units may be installed on combustible floors made from wood or class A, B or C roof covering materials.

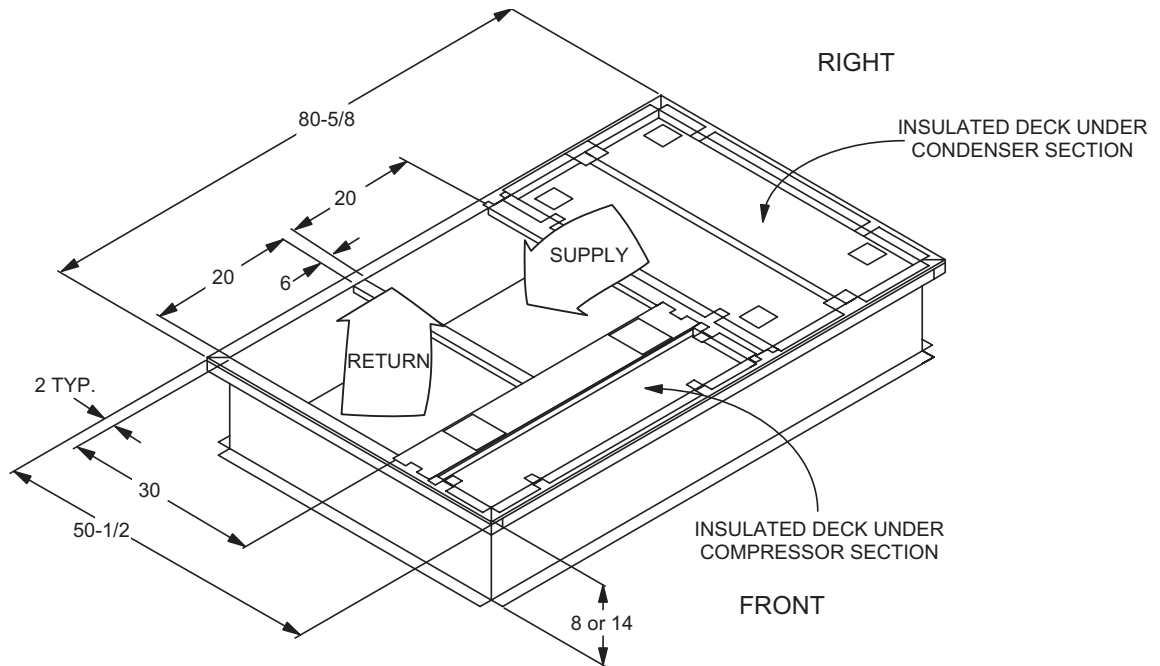

FIGURE 8 - PREDATOR® ROOF CURB DIMENSIONS

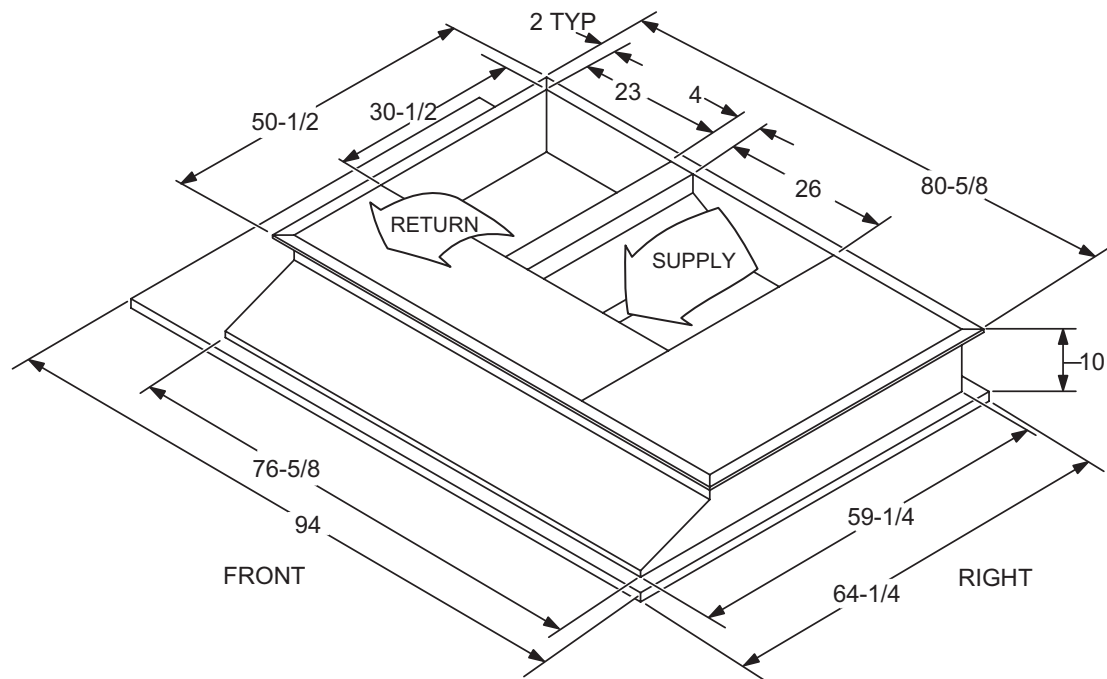

FIGURE 9 - SUNLINE™ TO PREDATOR® TRANSITION ROOF CURBS

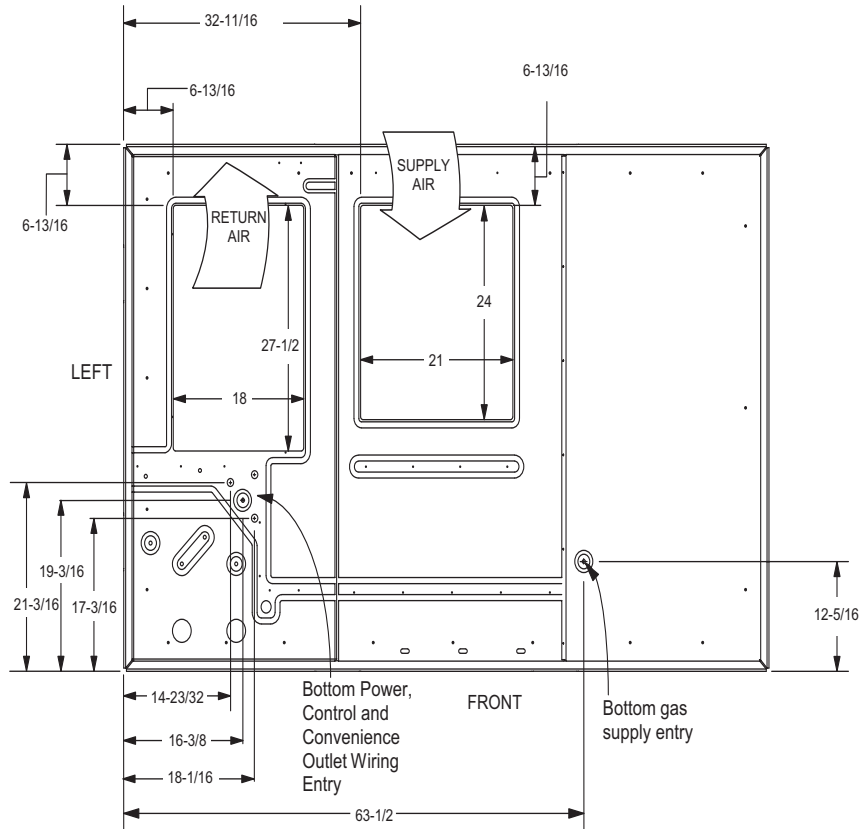

FIGURE 10 - BOTTOM DUCT OPENINGS (FROM ABOVE)

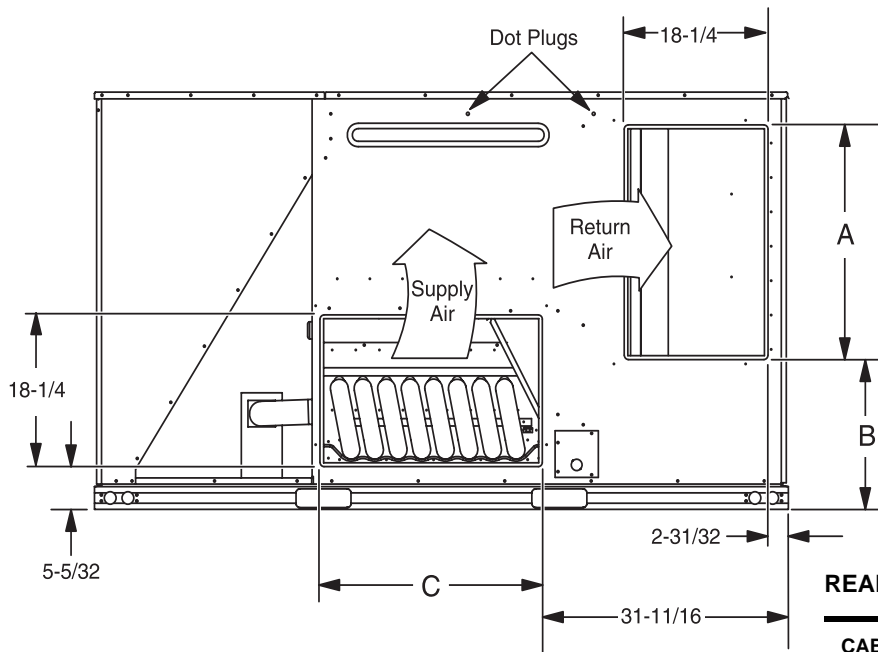

FIGURE 11 - REAR DUCT DIMENSIONS

REAR DUCT DIMENSIONS

CABINET SIZE	DIMENSION		
	"A"	"B"	"C"
50 3/4"	28 1/4"	18 1/16"	28 1/4"
42"	27 3/4"	12 1/16"	27 1/2"

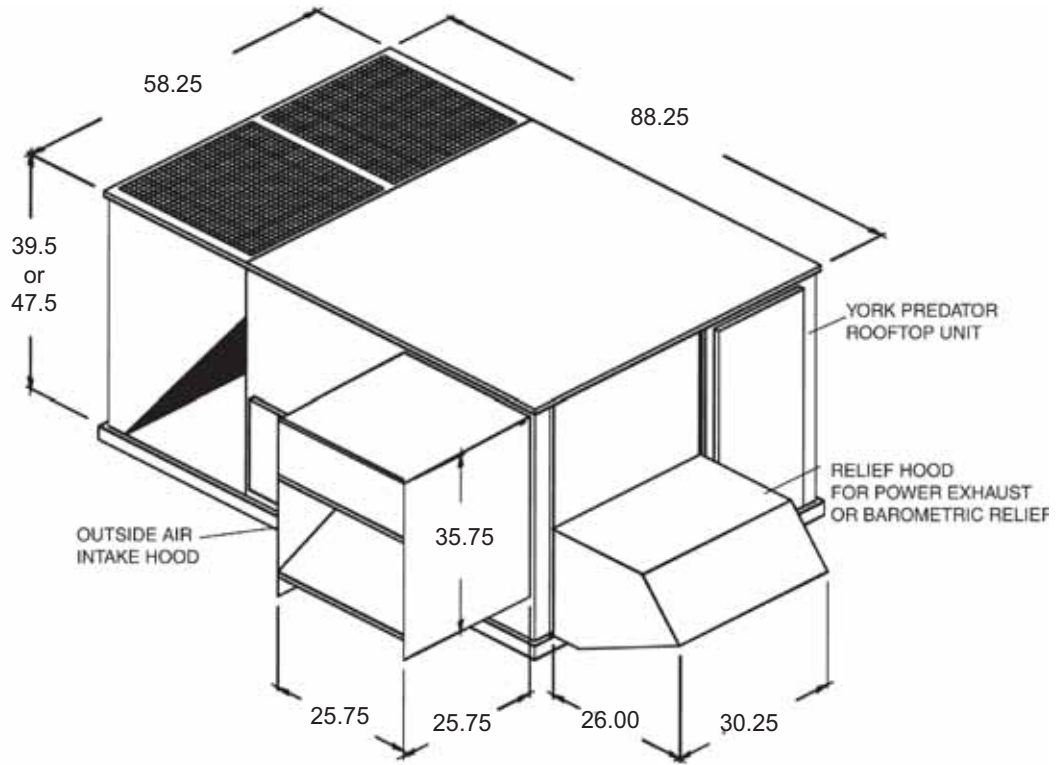

FIGURE 12 - DOWNFLOW ECONOMIZER HOOD DETAIL

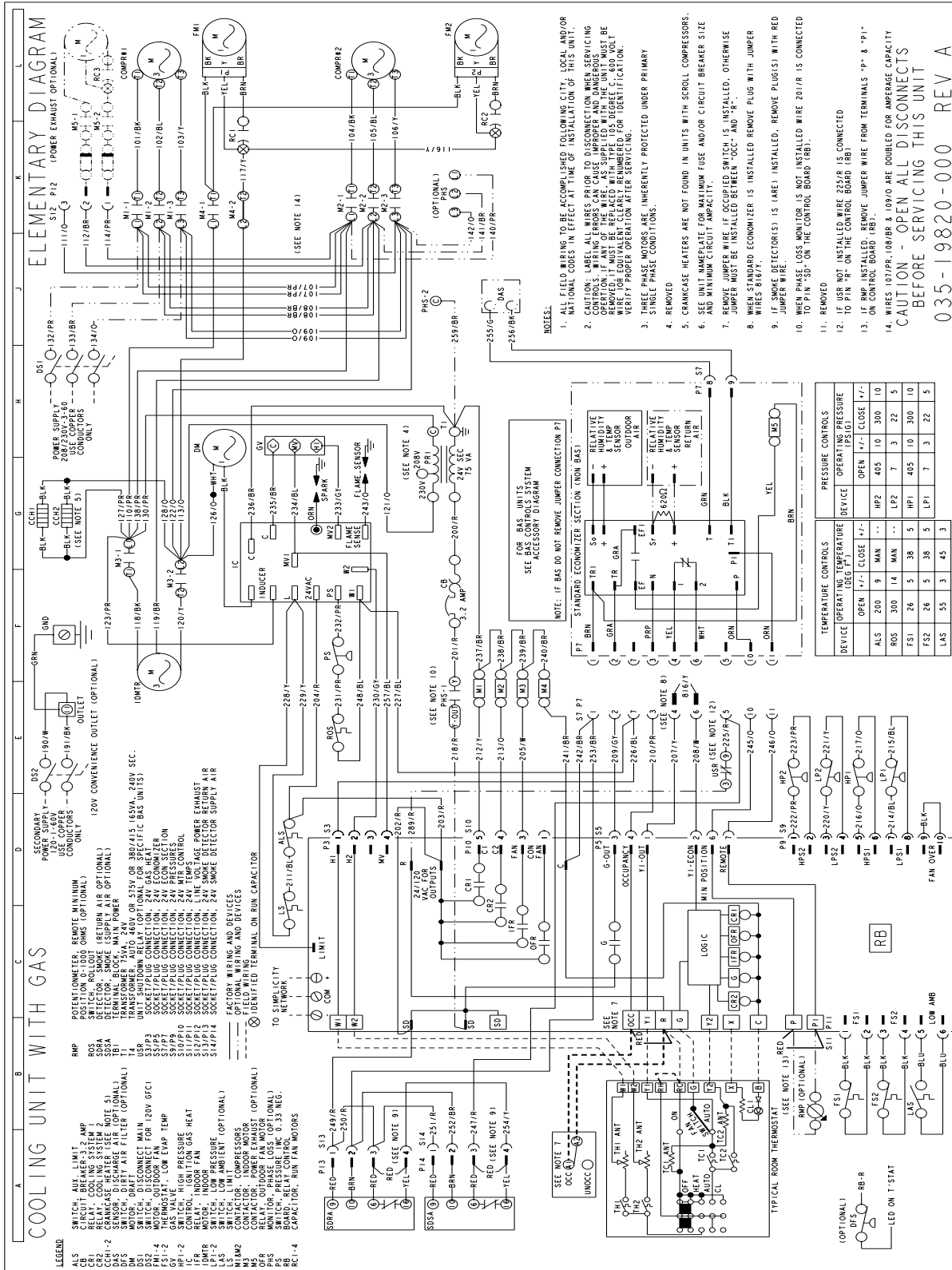

FIGURE 13 - COOLING UNIT WITH GAS HEAT WIRING 230 VOLT DIAGRAM

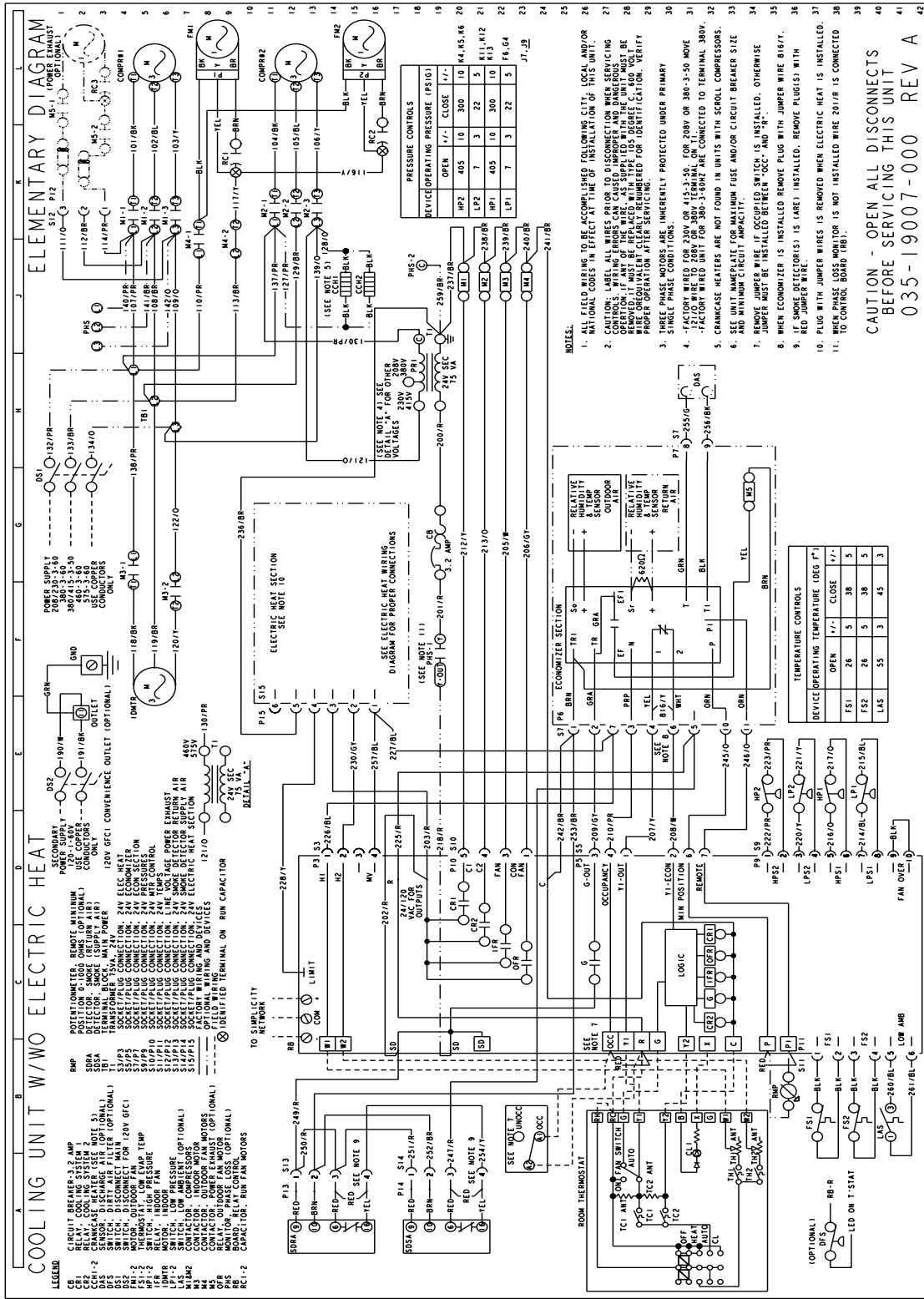

FIGURE 14 - COOLING UNIT WITH/WITHOUT ELECTRIC HEAT WIRING DIAGRAM

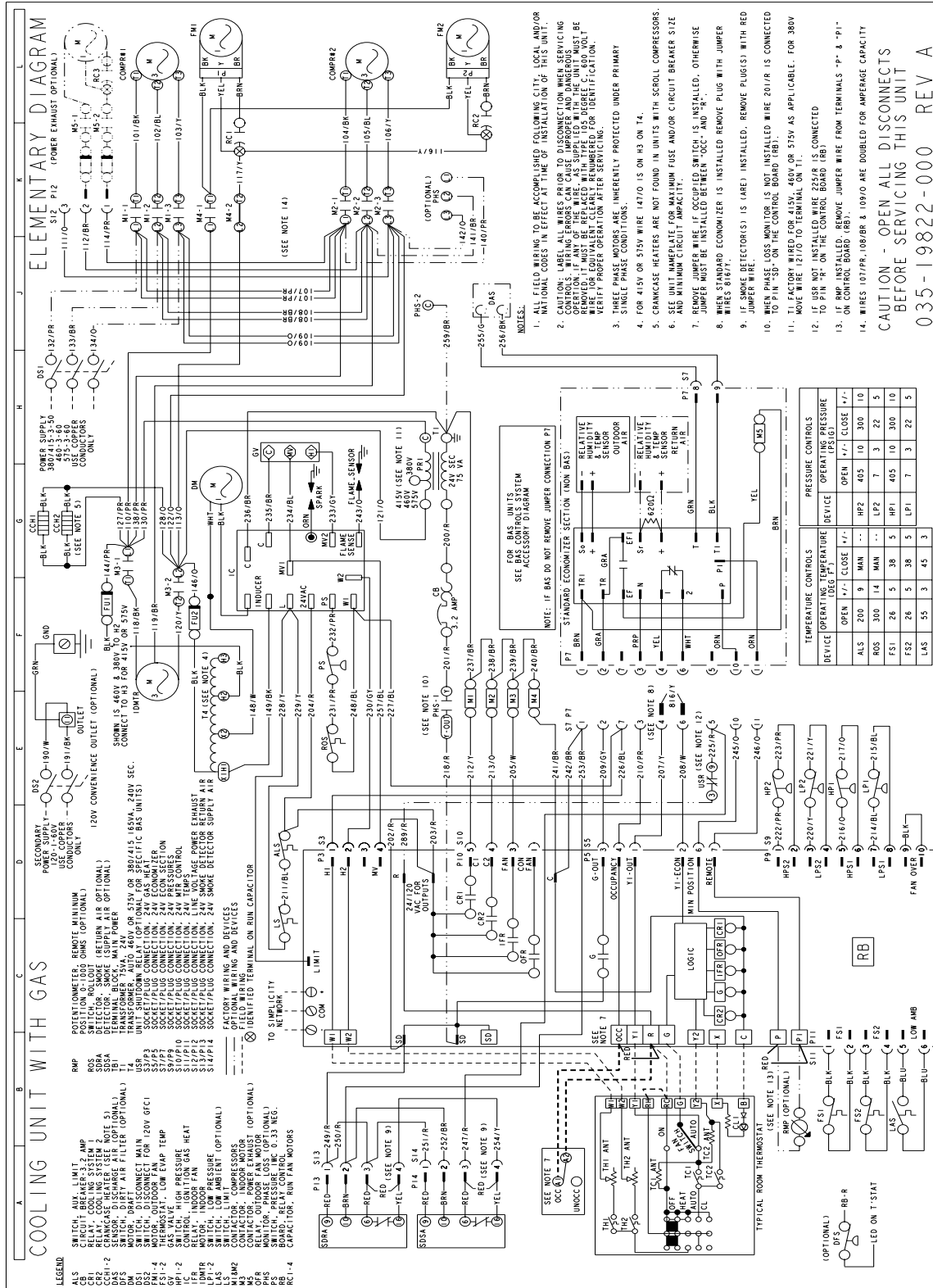

FIGURE 15 - COOLING UNIT WITH GAS HEAT WIRING 460, 575 VOLT 50 HZ DIAGRAM

GUIDE SPECIFICATIONS

PREDATOR® DH 078, 090, 102, 120 & 150, 11.5 EER

GENERAL

Units shall be manufactured by York International Unitary Products Group in an ISO 9001 certified facility. YORK® Predator® units are convertible single packages with a common footprint cabinet and common roof curb for all 6-1/2 through 12-1/2 ton models. All units have two compressors with independent refrigeration circuits to provide 2 stages of cooling. The units were designed for light commercial applications and can be easily installed on a roof curb, slab, or frame. All Predator® units are self-contained and assembled on rigid full perimeter base rails allowing for 3-way forklift access and overhead rigging. Every unit is completely charged, wired, piped, and tested at the factory to provide a quick and easy field installation. All units are convertible between side and down airflow. Independent economizer designs are used on side and down discharge applications, as well as all tonnage sizes. Predator® units are available in the following configurations: cooling only, cooling with electric heat, and cooling with gas heat. Electric heaters are available as factory-installed options or field-installed accessories.

DESCRIPTION

Units shall be factory assembled, single package, (Elec/Elec, Gas/Elec), designed for outdoor installation. Units shall have a minimum EER of 9.0. They shall have built in field convertible duct connections for down discharge supply/return or horizontal discharge supply/return and be available with factory installed options or field installed accessories. The units shall be factory wired, piped and charged with R-22 refrigerant and factory tested prior to shipment. All unit wiring shall be both numbered and color coded. The cooling performance shall be rated in accordance with DOE and ARI test procedures. Units shall be CSA certified to ANSI Z21.47 and UL 1995/CAN/CSA No. 236-M90 standards.

UNIT CABINET

Unit cabinet shall be constructed of G90 galvanized steel with exterior surfaces coated with a non-chalking, powder paint finish, certified at 1000 hour salt spray test per ASTM-B117 standards. Indoor blower sections shall be insulated with up to 1" thick insulation coated on the airside. Aluminum foil faced insulation shall be used in the unit's compartments and be fastened to prevent insulation from entering the air stream. Cabinet doors shall be hinged with toolless access for easy servicing and maintenance. Full perimeter base rails shall be provided to assure reliable transit of equipment, overhead rigging, fork truck access and proper sealing on roof curb applications. Disposable 2" filters shall be furnished and be accessible through hinged access door. Fan performance measuring ports shall be provided on the outside of the cabinet to allow accurate air measurements of evaporator fan performance without removing panels or creating bypass

of the coils. Condensate pan shall be slide out design, constructed of a non corrosive material, internally sloped and conforming to ASHRAE 62-B9 standards. Condensate connection shall be a minimum of 3/4" I.D. female and be rigid mount connection.

INDOOR (EVAPORATOR) FAN ASSEMBLY

Fan shall be a belt drive assembly and include an adjustable pitch motor pulley. Job site selected brake horsepower shall not exceed the motors nameplate horsepower rating plus the service factor. Units shall be designed to operate within the service factor. Fan wheel shall be double inlet type with forward curve blades, dynamically balanced to operate smoothly throughout the entire range of operation. Airflow design shall be constant volume. Bearings shall be sealed and permanently lubricated for longer life and no maintenance. Entire blower assembly and motor shall be slide out design.

OUTDOOR (CONDENSER) FAN ASSEMBLY

The outdoor fans shall be of the direct drive type, discharge air vertically, have aluminum blades riveted to corrosion resistant steel spider brackets and shall be dynamically balanced for smooth operation. The outdoor fan motors shall have permanently lubricated bearings internally protected against overload conditions and staged independently. A cleaning window shall be provided on two sides of the units for coil cleaning.

REFRIGERANT COMPONENTS

Compressors:

- A. Shall be fully hermetic type, direct drive, internally protected with internal high-pressure relief and over temperature protection. The hermetic motor shall be suction gas cooled and have a voltage range of + or - 10% of the unit nameplate voltage.
- B. Shall have internal spring isolation and sound muffling to minimize vibration and noise, and be externally isolated on a dedicated, independent mounting.

Coils:

- A. Evaporator and condenser coils shall have aluminum plate fins mechanically bonded to seamless internally enhanced copper tubes with all joints brazed. Special Phenolic coating shall be available as a factory option.
- B. Evaporator and condenser coils shall be of the direct expansion, draw-thru design.

Refrigerant Circuit and Refrigerant Safety Components shall include:

- A. Independent fixed-orifice or thermally operated expansion devices.
- B. Solid core filter drier/strainer to eliminate any moisture or foreign matter.
- C. Accessible service gage connections on both suction and discharge lines to charge, evacuate, and measure refrigerant pressure during any necessary servicing or troubleshooting, without losing charge.
- D. The unit shall have two independent refrigerant circuits, equally split in 50% capacity increments.

Unit Controls:

- A. Unit shall be complete with self-contained low-voltage control circuit protected by a resettable circuit breaker on the 24-volt transformer side.
- B. Unit shall incorporate a lockout circuit which provides reset capability at the space thermostat or base unit should any of the following standard safety devices trip and shut off compressor:
 - C. Loss-of-charge/Low-pressure switch.
 - (1) High-pressure switch.
 - (2) Freeze-protection thermostat, evaporator coil. If any of the above safety devices trip, an LED (light-emitting diode) indicator shall flash a diagnostic code that indicates which safety switch has tripped.
- D. Unit shall incorporate "AUTO RESET" compressor over temperature, over current protection.
- E. Unit shall operate with conventional thermostat designs and have a low voltage terminal strip for easy hook-up.
- F. Unit control board shall have on-board diagnostics and fault code display.
- G. Standard controls shall include anti-short cycle and low voltage protection, and permit cooling operation down to 0 °F.
- H. Control board shall monitor each refrigerant safety switch independently.
- I. Control board shall retain last 5 fault codes in non-volatile memory, which will not be lost in the event of a power loss.

GAS HEATING SECTION (IF EQUIPPED)

Heat exchanger and exhaust system shall be constructed of aluminized steel and shall be designed with induced draft combustion with post purge logic, energy saving direct spark ignition, and redundant main gas valve. The heat exchanger shall be of the tubular type, constructed of T1-40 aluminized steel for corrosion resistance and allowing minimum mixed air entering temperature of 40 °F. Burners shall be of the in-

shot type, constructed of aluminum-coated steel. All gas piping shall enter the unit cabinet at a single location, through either the side or bottom, without any field modifications. An integrated control board shall provide timed control of evaporator fan functioning and burner ignition. Heating section shall be provided with the following minimum protection:

- A. Primary and auxiliary high-temperature limit switches.
- B. Induced draft pressure sensor.
- C. Flame roll out switch (manual reset).
- D. Flame proving controls. Unit shall have two independent stages of capacity (60% 1st stage, 100% 2nd stage).

ELECTRIC HEATING SECTION (IF EQUIPPED)

An electric heating section, with nickel chromium elements, shall be provided in a range of 9 thru 54 KW, offering two states of capacity all sizes. The heating section shall have a primary limit control(s) (automatic reset) to prevent the heating element system from operating at an excessive temperature. The Heating Section assembly shall slide out of the unit for easy maintenance and service. Units with Electric Heating Sections shall be wired for a single point power supply with branch circuit fusing (where required).

UNIT OPERATING CHARACTERISTICS

Unit shall be capable of starting and running at 125 °F outdoor temperature, exceeding maximum load criteria of ARI Standard 210/240. The compressor, with standard controls, shall be capable of operation down to 0 °F outdoor temperature. Unit shall be provided with fan time delay to prevent cold air delivery before heat exchanger warms up. (Gas heat only)

ELECTRICAL REQUIREMENTS - All unit power wiring shall enter unit cabinet at a single factory provided location and be capable of side or bottom entry to minimize roof penetrations and avoid unit field modifications. Separate side and bottom openings shall be provided for the control wiring.

STANDARD LIMITED WARRANTIES - Compressor – 5 Years, Heat Exchanger – 10 Years, Elect. Heat Elem. – 5 Years, Parts – 1 Year

FACTORY INSTALLED OPTIONAL OUTDOOR AIR (Shall be made available by either/or):

1. **ELECTRONIC ENTHALPY AUTOMATIC ECONOMIZER** – Outdoor and return air dampers that are interlocked and positioned by a fully-modulating, spring-return damper actuator. The maximum leakage rate for the outdoor air intake dampers shall not exceed 2% when dampers are fully closed and operating against a pressure differential of 0.5 IWG. A unit-mounted potentiometer shall be provided to adjust the outdoor and return air damper assembly to take in outdoor air to meet the minimum ventilation requirement of the conditioned space during normal operation. During economizer operation, a mixed-air temperature control shall modulate the

outdoor and return air damper assembly to prevent the supply air temperature from dropping below 55 °F. Changeover from compressor to economizer operation shall be provided by an integral electronic enthalpy control that feeds input into the basic module. The outdoor intake opening shall be covered with a rain hood that matches the exterior of the unit. Water eliminator/filters shall be provided. Simultaneous economizer/compressor operation is also possible. Dampers shall fully close on power loss. Available with barometric relief or power exhaust.

2. **MOTORIZED OUTDOOR AIR DAMPERS** – Outdoor and return air dampers that are interlocked and positioned by a 2-position, spring-return damper actuator. The maximum leakage rate for the outdoor air intake dampers shall not exceed 2% when dampers are fully closed and operating against a pressure differential of 0.5 IWG. A unit-mounted potentiometer shall be provided to adjust the outdoor and return air damper assembly to take in the design CFM of outdoor air to meet the ventilation requirements of the conditioned space during normal operation. Whenever the indoor fan motor is energized, the dampers open up to one of two pre-selected positions – regardless of the outdoor air enthalpy. Dampers return to the fully closed position when the indoor fan motor is de-energized. Dampers shall fully close on power loss.

ADDITIONAL FACTORY INSTALLED OPTIONS

- **ALTERNATE INDOOR BLOWER MOTOR** – For applications with high restrictions, units are available with optional indoor blower motors that provide higher static output and/or higher airflow.
- **CONVENIENCE OUTLET (POWERED/NON-POWERED)**– Unit can be provided with an optional 120VAC GFCI outlet with cover on the corner of the unit housing the compressors.
- **ELECTRIC HEAT** - Electric Heaters range from 9 kW to 54 kW and are available in all the voltage options of the base unit.
- **PHASE MONITOR** - Designed to prevent damage in out-of-phase condition.
- **COIL GUARD** - Designed to prevent condenser coil damage.
- **BAS CONTROLS** - Include supply air sensor, return air sensor, dirty filter indicator and air proving switch.
- **DIRTY FILTER SWITCH** – This kit includes a differential pressure switch that energizes the fault light on the unit thermostat, indicating that there is an abnormally high-pressure drop across the filters.
- **BREAKER** – An HACR breaker can be factory installed on gas heat units or cooling units with electric heat.
- **DISCONNECT SWITCH** - A disconnect can be factory installed on a cooling only units sized for the largest electric heat available.
- **STAINLESS STEEL HEAT EXCHANGER** – For applications in a corrosive environment, this option provides a full stainless steel heat exchanger assembly.
- **SMOKE DETECTOR** – A smoke detector can be factory mounted and wired in the supply and/or return air compartments.

OTHER PRE-ENGINEERED ACCESSORIES AVAILABLE

- **ROOF CURB** - 14" and 8" high, full perimeter knockdown curb, with hinged design for quick assembly.
- **BAROMETRIC RELIEF DAMPER** – (Unit mounted – Downflow, Duct Mounted – Horizontal) – Contains a rain hood, air inlet screen, exhaust damper and mounting hardware. Used to relieve internal air pressure through the unit during economizer operation.
- **PROPANE CONVERSION KIT** – Contains new orifices and gas valve springs to convert from natural to L.P. gas.
- **60°F GAS HEAT KIT** – Provides an electric heat kit for the gas compartment for use in extreme low ambient conditions.
- **ECONOMIZER** (Downflow and Horizontal flow)
- **POWER EXHAUST** – (Unit mount – Downflow, Duct mount – Horizontal flow)
- **DUAL ENTHALPY KIT** - Provides a second input to economizer to monitor return air.

Subject to change without notice. Printed in U.S.A.
Copyright © 2005 by Unitary Products. All rights reserved.

036-21059-007-B-1005
Supersedes: 036-21059-007-A-0805

**Unitary
Products
Group**

**5005
York
Drive**

**Norman
OK
73069**