

## Product Data

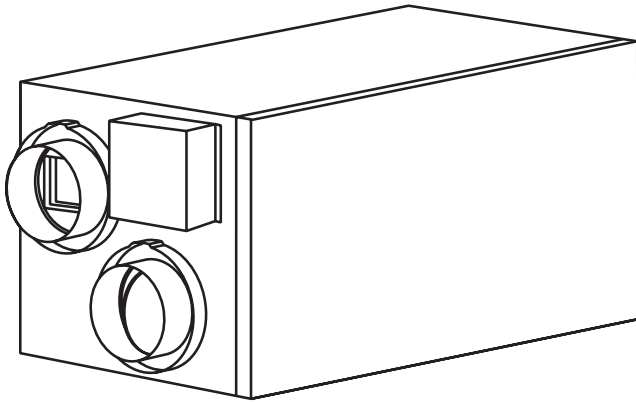

A07619

The Energy Recovery Ventilation (ERV) system offered by Carrier is the finest on the market today. The ERV provides efficient and cost effective heat recovery during the heating season when needed most.

As temperatures drop below 23°F (-5°C), indoor air is recirculated periodically through the heat exchanger core to prevent frost from forming. Competitors' methods of supplementary electric defrost waste energy. Unlike rotary wheel heat exchangers which mix air streams, these cross-flow or counterflow heat exchangers ensure that there is no mixing of the stale air stream with the fresh outdoor air stream.

A filter installed on the incoming outdoor air stream removes large airborne particles from the intake air stream before they enter the heat exchanger and reduces the maintenance required. (A filter is also installed on the outgoing air stream, up stream of the heat exchanger core.) The units' acoustically engineered design makes the Carrier ERV the quietest on the market and ensures that comfort is felt, not heard.

Unlatching two (2) suitcase style latches allows easy removal of the filters and core for cleaning.

### STANDARD FEATURES

- Drainless design
- Integrated airflow balancing points
- Integrated furnace interlock
- Acoustical design
- Onboard control for continuous high/low ventilator operation
- Energy saving defrost cycle
- Cross-flow, counterflow heat exchangers
- One filter on incoming air; one filter on outgoing air to protect core
- No-tools maintenance
- Enthalpic heat exchanger core

# MODEL NUMBER NOMENCLATURE

|                            |           |                        |                   |                    |
|----------------------------|-----------|------------------------|-------------------|--------------------|
| <b>ERV</b>                 | <b>CC</b> | <b>LHA</b>             | <b>1</b>          | <b>150</b>         |
| Product Type               | Brand     | Model Type             | Electrical Supply | Maximum Capacity   |
| Energy Recovery Ventilator | Carrier   | LHA – Large Horizontal | 1 – 115 Volts     | 150 CFM<br>200 CFM |



ERVCLHA

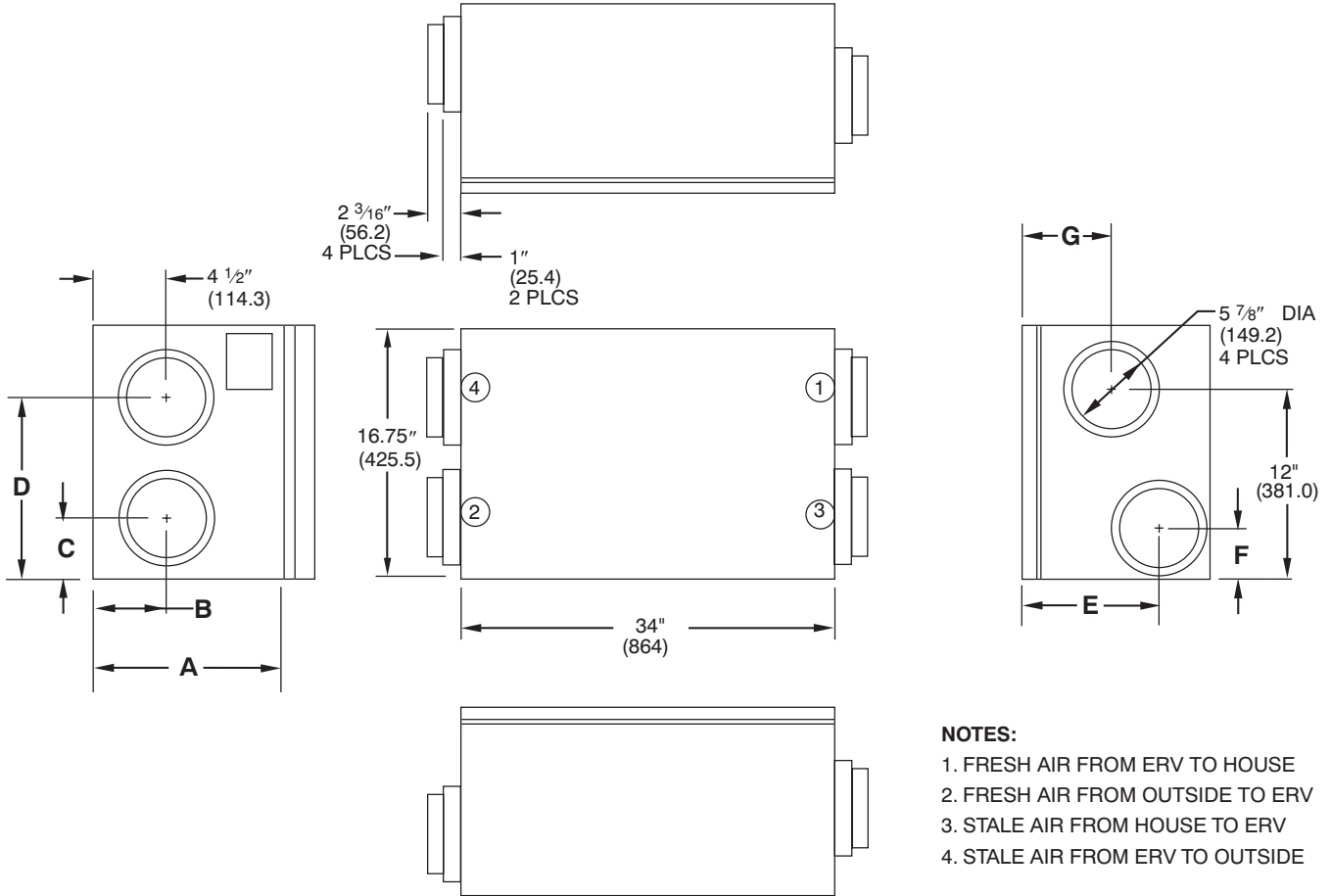

**NOTES:**

1. FRESH AIR FROM ERV TO HOUSE
2. FRESH AIR FROM OUTSIDE TO ERV
3. STALE AIR FROM HOUSE TO ERV
4. STALE AIR FROM ERV TO OUTSIDE

A07638

## DIMENSIONS

| MODEL   | A      |       | B   |     | C     |       | D   |       | E     |       | F     |     | G     |       |
|---------|--------|-------|-----|-----|-------|-------|-----|-------|-------|-------|-------|-----|-------|-------|
|         | in.    | mm    | in. | mm  | in.   | mm    | in. | mm    | in.   | mm    | in.   | mm  | in.   | mm    |
| ERVCLHA | 17-1/4 | 438.2 | 10  | 254 | 4-1/2 | 114.3 | 11  | 279.4 | 7-3/4 | 196.9 | 4-1/4 | 108 | 9-1/2 | 241.3 |

# Climate Map for Energy and Heat Recovery Ventilators

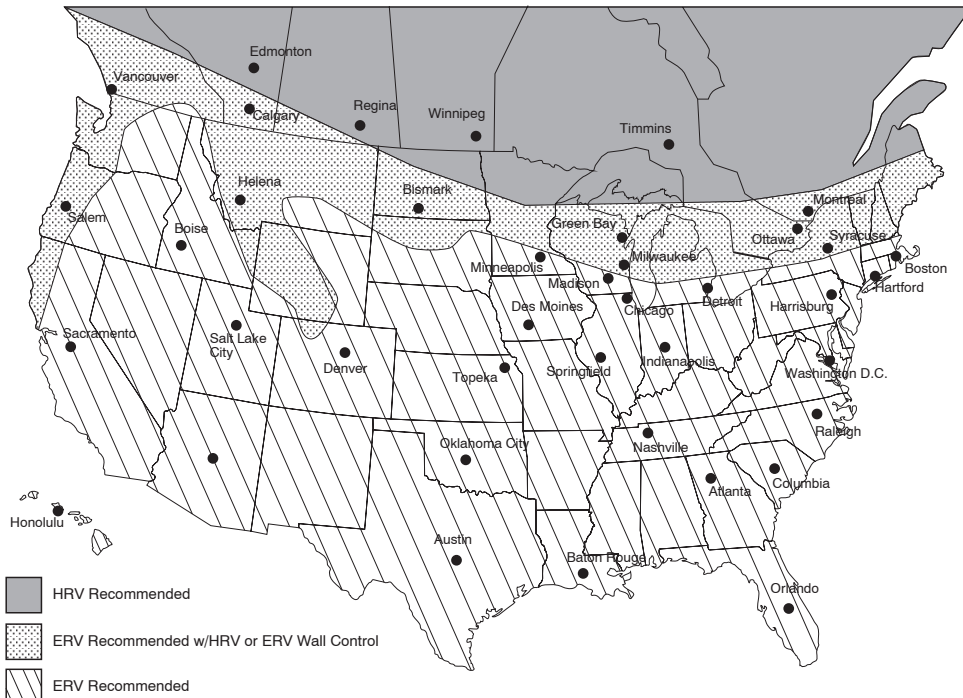

ERVCLHA

## PHYSICAL DATA

| MODEL                        | ERVCLHA1150                          | ERVCLHA1200                          |
|------------------------------|--------------------------------------|--------------------------------------|
| Port Locations               | Sides                                | Sides                                |
| Core Type                    | Enthalpic transfer media, cross flow | Enthalpic transfer media, cross flow |
| Weight — lb (kg)             | 74 (33.6)                            | 76 (34.5)                            |
| Shipping Weight — lb (kg)    | 78 (35.4)                            | 80 (36.3)                            |
| Shipping Dimensions in. (mm) |                                      |                                      |
| Height                       | 19.75 (502)                          | 19.75 (502)                          |
| Width                        | 20.5 (521)                           | 20.5 (521)                           |
| Length                       | 40.5 (1029)                          | 40.5 (1029)                          |

| MODEL                                                 | ERVCLHA1150 | ERVCLHA1200 |
|-------------------------------------------------------|-------------|-------------|
| Capacity—CFM @ 0.5-0.3ESP (in. wc)                    | 60–148      | 60–183      |
| Efficiency (Sensible)—Percent                         |             |             |
| 32°F (0° C)                                           | 60          | 58          |
| -13°F (-25° C)                                        | 49          | 41          |
| Efficiency (Latent)—Percent                           |             |             |
| @ all temperatures                                    | 58          | 53          |
| Cooling Season Total Recovery Efficiency 95°F (35° C) | 56          | 52          |

| MODEL             | ERVCLHA1150 | ERVCLHA1200 |
|-------------------|-------------|-------------|
| Voltage           | 120         | 120         |
| Max Power — watts | 150         | 240         |
| Max Amps          | 1.3         | 2.1         |

## METHODS TO SIZE ERVs

### METHOD 1

1. Calculate cu ft of occupied space.
2. Multiply by recommended air changes per hr (AC/h).
3. Divide by 60 minutes per hr to convert to CFM.

#### Example:

2000 sq ft with 8 ft ceiling, 0.35 air changes per hr (AC/h)  
 $(2000 \text{ sq ft} \times 8 \text{ ft ceiling} \times 0.35 \text{ AC/h}) / 60 \text{ min/h} = 93.3 \text{ CFM}$

### METHOD 2

1. Multiply number of people times 15 CFM/person.
2. Multiply number of bath rooms 20 CFM/each.
3. Add 25 CFM for kitchen.

#### Example:

2 people, 2 baths, 1 kitchen  
 $(2 \times 15) + (2 \times 20) + 25 = 95 \text{ CFM}$

## HEATING AND COOLING LOAD CHARTS

Although the ventilators process the outside air before it enters the home, additional heating and cooling loads need to be considered.

### HEATING LOAD BTUH

| Outside Temp °F | Heating Load (Btuh) @ Inside Design Temp 72°F |        |        |        |
|-----------------|-----------------------------------------------|--------|--------|--------|
|                 | ERV150                                        | ERV200 | HRV150 | HRV250 |
| -25             | 5186                                          | 8143   | 6636   | 10603  |
| -20             | 4919                                          | 7723   | 6294   | 10057  |
| -15             | 5075                                          | 7967   | 5952   | 9510   |
| -10             | 4783                                          | 7509   | 5610   | 8964   |
| -5              | 4491                                          | 7051   | 5268   | 8417   |
| 0               | 4200                                          | 6594   | 4925   | 7871   |
| 5               | 4234                                          | 6647   | 4583   | 7324   |
| 10              | 3918                                          | 6151   | 4241   | 6777   |
| 15              | 3958                                          | 6214   | 3899   | 6231   |
| 20              | 3611                                          | 5669   | 3557   | 5684   |
| 25              | 3264                                          | 5124   | 3215   | 5138   |
| 30              | 2916                                          | 4579   | 2873   | 4591   |
| 35              | 2569                                          | 4034   | 2531   | 4045   |
| 40              | 2222                                          | 3489   | 2189   | 3498   |

The heating load chart shows the heating loads in Btuh for a range of winter design temperatures for each model of ventilator.

EXAMPLE: The heating design temperature for Little Rock, AR is 20°F. The additional heating load of the ERVCCLHA1200 at 20°F is 559 Btuh. This additional load should be taken into consideration when sizing the heating equipment.

### COOLING LOAD BTUH

| Outside Enthalpy Btu/lb | Cooling Load (Btuh) @ Inside Design Temp 72°F and 50% Relative Humidity |        |        |        |
|-------------------------|-------------------------------------------------------------------------|--------|--------|--------|
|                         | ERV150                                                                  | ERV200 | HRV150 | HRV250 |
| 30                      | 380                                                                     | 640    | 670    | 1071   |
| 31                      | 618                                                                     | 1040   | 1090   | 1741   |
| 32                      | 855                                                                     | 1441   | 1509   | 2411   |
| 33                      | 1093                                                                    | 1841   | 1928   | 3080   |
| 34                      | 1331                                                                    | 2241   | 2347   | 3750   |
| 35                      | 1568                                                                    | 2641   | 2766   | 4419   |
| 36                      | 1806                                                                    | 3041   | 3185   | 5089   |
| 37                      | 2043                                                                    | 3441   | 3604   | 5759   |
| 38                      | 2281                                                                    | 3842   | 4023   | 6428   |
| 39                      | 2519                                                                    | 4242   | 4442   | 7098   |
| 40                      | 2756                                                                    | 4642   | 4861   | 7767   |
| 41                      | 2994                                                                    | 5042   | 5280   | 8437   |
| 42                      | 3231                                                                    | 5442   | 5699   | 9107   |

The cooling load chart shows loads in Btuh as well. To use the cooling load chart, first find the design enthalpy from a psychrometric chart using the design dry bulb and wet bulb temperatures. (See pg. 7.) The cooling load can then be found for a range of enthalpies for each ventilator.

EXAMPLE: The design dry bulb temperature for Miami is 90°F and the average wet bulb at that temperature is 77°F. Using the psychrometric chart, the enthalpy is about 40.5 Btu per pound (Btu/lb) of dry air, which would round up to 41 Btu/lb dry air. In the left column, at 41 Btu/lb dry air, the ERVCCLHA1200 has an additional cooling load of 5042 Btuh, while the HRV150CFM unit has an additional cooling load of 8437 Btuh.

ERVCLHA

# PSYCHROMETRIC CHART

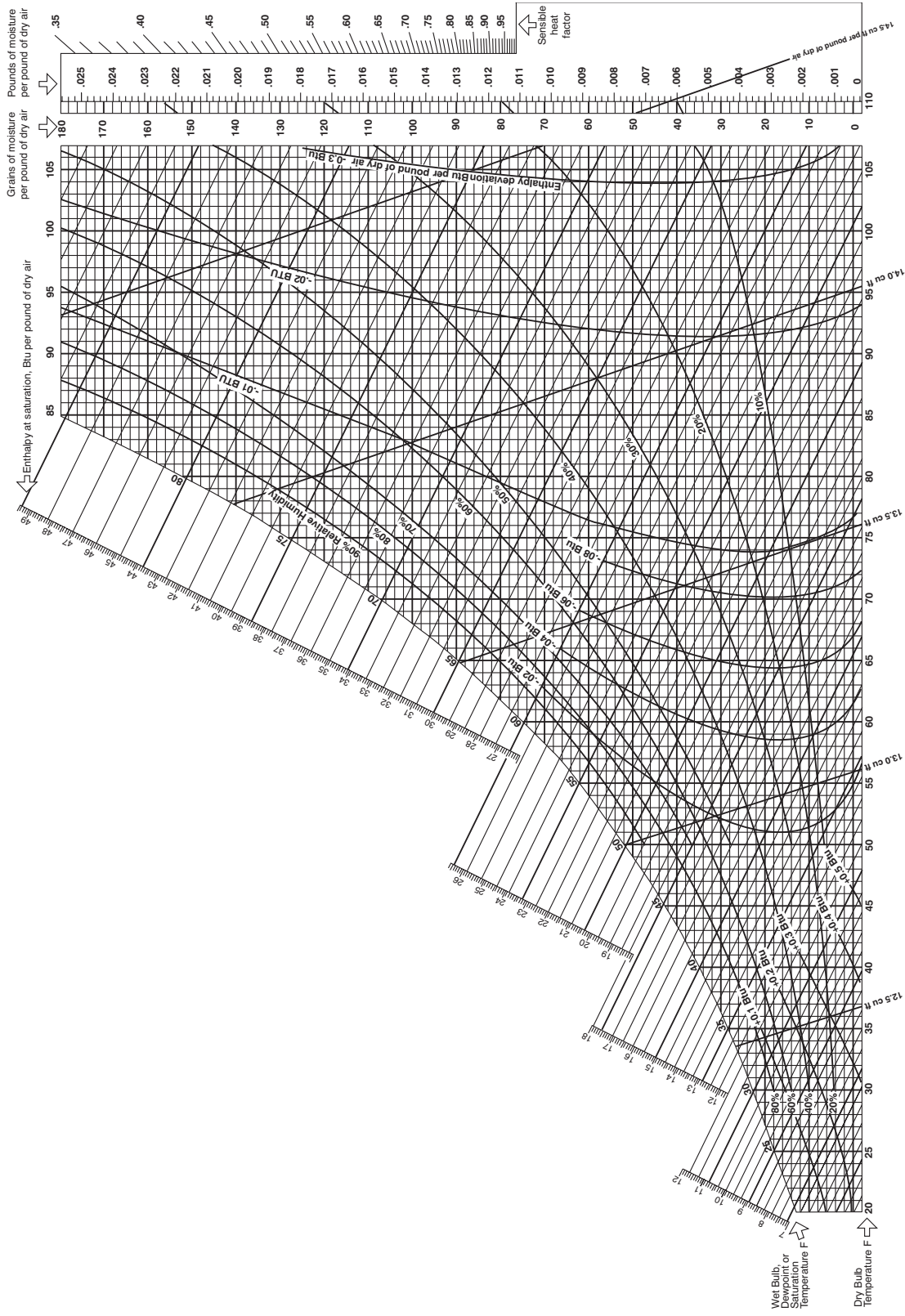

Below 32°F, properties and enthalpy deviation lines are for ice.

A96394



# ACCESSORIES

| ITEM                          | ACCESSORY PART NO. | ERVCLHA SIZE USED WITH |
|-------------------------------|--------------------|------------------------|
| Carrier OneTouch Control      | KVBCN0101CLT       | All                    |
| Carrier Basic Wall Control    | KVBCN0101CBS       | All                    |
| Carrier Latent Wall Control   | KVACN0101CLC       | All                    |
| 60–Minute Timer Kit           | KVATM010160M       | All                    |
| Carrier 20–Minute Push Button | KVATM010120C       | All                    |
| Airflow Measuring Kit         | KVBAC0101KIT       | All                    |
| Hood (2 required)             | KVAAC0101HOD       | All                    |

## ACCESSORY DESCRIPTION, SUGGESTED AND REQUIRED USE

### Carrier OneTouch Control

Control option choice. Used with all ERVs as a main wall control.

### Carrier Basic Wall Control

Control option choice. Can be used with all ERVs.

### Carrier Latent Wall Control

Control option choice. Can be used with all ERVs.

### 60–Minute Timer Kit

Used with all ERVs, time is adjustable between 10 and 60 minutes.

### Carrier 20–Minute Push Button

Used with all ERVs when 20 minute manual operation is required

### Airflow Measuring Kit

Start up Balancing Kit, includes Magnehelic Gauge

### Hood (2 required)

Used with all ERVs. Exterior intake and exhaust hoods.

ERVCLHA

| Control Description | Fan Speed Control | Humidistat Control | Continuous Mode | Intermittent Mode |
|---------------------|-------------------|--------------------|-----------------|-------------------|
| OneTouch            | Yes               | No                 | Yes             | Yes               |
| Latent              | Yes               | Yes                | Yes             | Yes               |

### Control features

#### OneTouch Control:

Allows control of ventilator with the touch of a button. This control will operate as a main wall control. The OneTouch will operate the unit in Intermittent Mode (20 minutes per hour), continuous low speed, continuous high speed, and off.

#### Latent Control:

Low Exchange Mode—If the relative humidity inside the building is lower than selected, air exchange would occur with the outside at high speed. If the relative humidity inside the building is higher than selected, air exchange would occur with the outside at low speed. This ensures continuous air exchange for constant air quality.

Intermittent Mode—If the relative humidity inside the building is higher than selected, no air exchange would occur and the system would turn off. If the relative humidity inside the building is lower than selected, air exchange would occur with outside at high speed. this mode is ideal for maintaining the proper humidity level when the continuous mode cannot.

#### Automatic Defrost Cycle Features

All models offer a non-electric defrost cycle feature which prevents frost and ice buildup within the heat recovery core. When the outside air temperature falls below 23°F (-5°C) it is electronically sensed and the dampers close the outside air ports. This allows warm indoor air to recirculate within the heat recovery core. The frequency of this cycle increases as the outside air temperature decreases.

| Model   | 25°F<br>(-5°C) |            | 4°F TO -17°F<br>(-15.6°C TO -27.3°C) |            | BELOW -18°F<br>(-27.8°C) |            |
|---------|----------------|------------|--------------------------------------|------------|--------------------------|------------|
|         | DEFROST*       | EXCHANGE†  | DEFROST*                             | EXCHANGE†  | DEFROST*                 | EXCHANGE†  |
| ERVCLHA | 10 Minutes     | 60 Minutes | 10 Minutes                           | 30 Minutes | 10 Minutes               | 20 Minutes |

\* All defrost times are in the standard mode (as shipped)

† Time between defrost when within specified temperature range