

Comfort™ 92 Model 58MXB
Highly-Efficient 4-Way Multipoise Fixed-Capacity
Deluxe Condensing Gas Furnace
Input Rates: 40,000 thru 138,000 Btuh

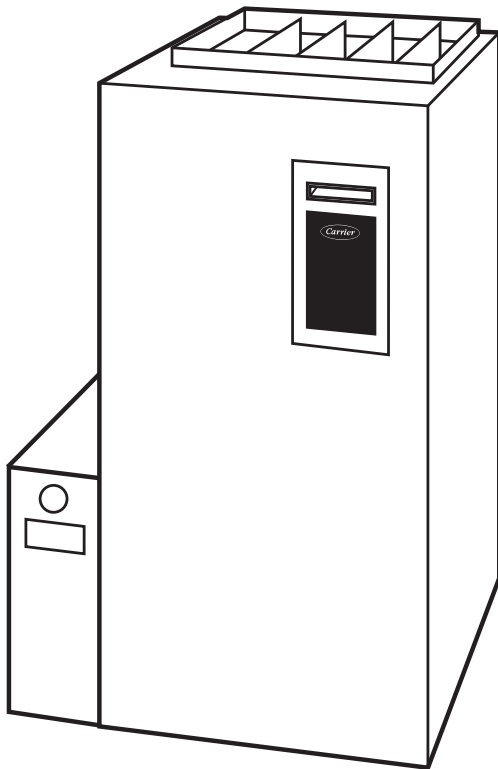

Turn to the Experts.™

Product Data



A05069

4-WAY MULTIPOISE DESIGN ALLOWS MORE APPLICATIONS . . .

The Comfort™ 92 is a must for your product line. This high-efficiency furnace allows more applications with its reliable 4-way multipoise design. The Comfort™ 92 is available in 12 heat/airflow combinations and with the 4-way multipoise design can be installed in upflow, downflow, or horizontal positions covering up to 48 different applications. With the exception of the 140 size unit, all Comfort™ 92 models can be installed in a manufactured (mobile) home when the optional kit is used, and in installations with elevations up to 10,000 ft. (3048 M) (140 size unit limitation 7,000 ft. (2134 M)). The furnace is factory configured for upflow application. With the exception of the 140 size, all sizes can be installed with 2- pipe or 1-pipe venting. The 140 size can be installed only as a 2-pipe system.

This versatile unit utilizes Power Heat™ hot surface ignition (HSI) which ignites the burners directly. HSI eliminates gas waste that typical continuous-pilot designs can bring. Hot surface ignition provides reliable startup and operation.

Take a look at the control center on the Comfort™ 92. Control of ignition, inducer, and blower operation is all handled in one central printed circuit board. The status indicator on the control signals when a fault has occurred and identifies where the problem is. This, along with the component test feature, makes the Comfort™ 92 one of the easiest gas furnaces to troubleshoot.

High efficiency is achieved by maximizing heat transfer. The result is energy-saving efficiency, up to 95.5 percent Annual Fuel Utilization Efficiency (AFUE), and reduced operational noise. The Comfort™ 92 is one of the quietest furnaces in the industry.

A unique feature of this unit is the patented polypropylene-laminated heat exchanger. This secondary heat exchanger ensures that all available heat is properly transferred to the airstream and throughout the home. Using the exclusive flow-through design, the secondary heat exchanger reduces the pressure drop in the furnace which leads to lower electrical usage, an important part of this unit's efficiency. Carrier heat exchangers are backed by a Limited Lifetime Warranty. (See Warranties section for details.)

When we put it all together, the Comfort™ 92 combines quality and design to bring high efficiency and comfort. You will enjoy the versatility and ease of installation of this unit. The Comfort™ 92 is equipped for either left or right-side connections. Blower speeds are easily adjustable with speed-taps conveniently located on the control center. A combustion inducer allows for more use of 2-in. vent and combustion-air piping, keeping installation costs low.

As with other Carrier furnaces, this model is designed to work as a part of the total home comfort system which includes elements for cooling, air cleaning, humidification, ventilation, and zoning.

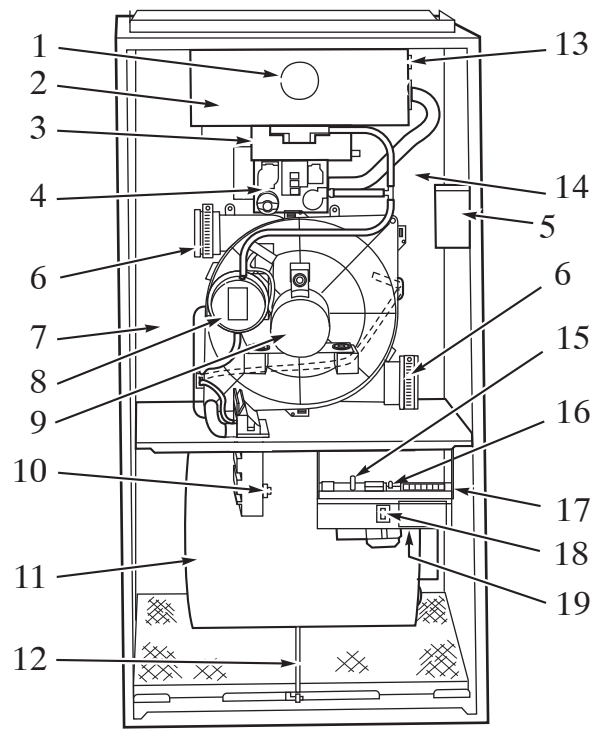

A02173

NOTE:

- The 58MXB Furnace is built for use with natural gas. The furnace can be converted for propane gas with a factory-authorized and listed accessory conversion kit.
- Control location and actual controls may be different than shown above.

- | | |
|--|--|
| <ol style="list-style-type: none"> 1. Burner sight glass for viewing burner flame. 2. Burner assembly (inside), operates with energy-saving, inshot burners and hot surface igniter for safe, dependable heating. 3. Combustion-air intake connection to ensure contaminant-free air (right or left side). 4. Redundant gas valve, safe, efficient, features 1 gas control with 2 internal shutoff valves. 5. Junction box for 115-v electrical power supply. (right or left side) 6. Vent outlet uses sealed PVC pipe to carry vent gases from the furnace's combustion system (right or left side). 7. Secondary condensing heat exchanger (inside), wrings out more heat through condensation of gases. Constructed with polypropylene-laminated steel to ensure durability. 8. Pressure switch ensures adequate flow of flue products through furnace and out vent system. 9. Inducer motor pulls hot flue gases through the heat exchangers, maintaining negative pressure for added safety. | <ol style="list-style-type: none"> 10. Condensate drain connection collects moisture condensed during the combustion process. 11. Heavy-duty blower circulates air across the heat exchangers to transfer heat into the home. 12. Air filter and retainer may be used for side or bottom return application. 13. Rollout switch (manual reset) to prevent overtemperature in burner area. 14. Primary serpentine heat exchanger (inside). Stretches fuel dollars with the S-shaped heat-flow design. Solid weld-free construction of corrosion-resistant aluminized steel means reliability. 15. A 3-amp fuse provides electrical and component protection. 16. Light emitting diode (LED) on control center. Code lights are for diagnosing furnace operation and service requirements. 17. Control center. 18. Blower access panel safety interlock switch. 19. Transformer (24v) behind control center provides low-voltage power to furnace control center and thermostat. |
|--|--|

MODEL NUMBER NOMENCLATURE

58MXB

040

F

100

08

Deluxe 4-Way Multipoise Fixed-Capacity Direct-Vent (2-pipe) and Non-Direct Vent (1-pipe) Condensing Gas Furnace

Cooling Airflow
 (Nominal 400 CFM per 12,000 Btuh Cooling)
 08 — 800 CFM
 12 — 1200 CFM
 16 — 1600 CFM
 20 — 2000 CFM

Input Rates

040 — 40,000 Btuh	100 — 100,000 Btuh
060 — 60,000 Btuh	120 — 120,000 Btuh
080 — 80,000 Btuh	140 — 138,000 Btuh

Series

Media Filter Cabinet included

58MXB



MEETS DOE RESIDENTIAL CONSERVATION SERVICES PROGRAM STANDARDS

Before purchasing this appliance, read important energy cost and efficiency information available from your retailer.



As an ENERGY STAR® Partner, Carrier Corporation has determined that this product meets the ENERGY STAR® guidelines for energy efficiency.

ISO 9001:2000



REGISTERED QUALITY SYSTEM

These products are engineered and manufactured under an ISO 9001 registered quality system.

SPECIFICATIONS

UNIT SIZE		040-08	040-12	060-08	060-12	060-16	080-12	
RATINGS AND PERFORMANCE								
Input Btuh*		40,000	40,000	60,000	60,000	60,000	80,000	
Output Capacity BTUH* (ICS) (Shaded capacities are specified on rating plate)	Direct Vent (2-Pipe)	Upflow	38,000	38,000	56,000	56,000	75,000	
		Downflow	38,000	38,000	56,000	56,000	75,000	
		Horizontal	38,000	38,000	56,000	56,000	74,000	
	Non-Direct Vent (1-Pipe)	Upflow	38,000	38,000	56,000	56,000	75,000	
		Downflow	38,000	38,000	56,000	56,000	74,000	
		Horizontal	38,000	38,000	56,000	56,000	74,000	
AFUE% Nonweather- ized ICS	Direct Vent (2-Pipe)	Upflow	94.3	95.5	93.0	93.0	93.0	
		Downflow	92.9	94.0	91.5	91.5	91.5	
		Horizontal	93.9	94.9	92.3	92.3	92.3	
	Non-Direct Vent (1-Pipe)	Upflow	92.4					
		Downflow	91.4					
		Horizontal	91.4					
Certified Temperature Rise Range ° F (° C)		30-60 (17-33)	15-45 (8-25)	45-75 (25-41)	30-60 (17-33)	20-50 (11-28)	40-70 (22-39)	
Certified External Static Pressure	Heating	0.10	0.10	0.12	0.12	0.12	0.15	
	Cooling	0.50	0.50	0.50	0.50	0.50	0.50	
Airflow CFM‡	Heating	850	1125	885	1065	1320	1190	
	Cooling	895	1215	900	1200	1545	1245	
ELECTRICAL								
Unit Volts-Hertz-Phase		115-60-1						
Operating Voltage Range Min-Max**		104-127						
Maximum Unit Amps		6.1	7.3	6.1	7.1	9.5	7.6	
Unit Ampacity††		8.4	10.0	8.4	9.8	12.8	10.4	
Minimum Wire Size		14	14	14	14	14	14	
Maximum Wire Length Ft. (M)‡‡		44 (13.4)	37 (11.2)	44 (13.4)	38 (11.5)	29 (8.8)	36 (10.9)	
Maximum Fuse Size or Ckt Bkr Amps (Time-Delay Type Recommended)		15	15	15	15	15	15	
Transformer (24v)		40va						
External Control Power Available	Heating	12va						
	Cooling	21va						
Air Conditioning Blower Relay		Standard						
CONTROLS								
Limit Control		SPST						
Heating Blower Control (Off Delay)		Selectable 90, 120, 150, or 180 Sec						
Burners (Monoport)		2	2	3	3	3	4	
Gas Connection Size		1/2-in. NPT						
GAS CONTROLS								
Gas Valve (Redundant)		Manufacturer		White-Rodgers				
		Min Inlet Pressure (In. wc)		4.5 (Natural Gas)				
		Max Inlet Pressure (In. wc)		13.6 (Natural Gas)				
Ignition Device		Hot Surface						
BLOWER DATA								
Direct-Drive Motor HP (Permanent Split Capacitor)		1/5	1/3	1/5	1/3	1/2	1/3	
Motor Full Load Amps		4.9	5.8	4.9	5.8	7.9	5.8	
RPM (Nominal) -Speeds		1075-3	1075-4	1075-3	1075-4			
Blower Wheel Diameter x Width - In. (mm)		10 x 6 (254 x 152)	10 x 7 (254 x 178)	10 x 6 (254 x 152)	10 x 7 (254 x 178)	11 x 8 (279 x 203)	10 x 7 (254 x 178)	
Filter Size - In. (mm)		(1) 16 x 25 x 3/4 (406 x 635 x 19)						
FACTORY-AUTHORIZED AND LISTED, DEALER-INSTALLED OPTIONS								
Gas Conversion Kit-Natural-to-Propane		KGANP4601ALL						
Gas Conversion Kit-Propane-to-Natural		KGAPN3901ALL						
Twinning Kit		N/A				KGATW 0601HSI	N/A	
Manufactured (Mobile) Home Kit		KGAMH0301KIT						
Downflow Base***		KGASB0301ALL						
Vent Termination Kit (Bracket Only for 2 Pipes)		2-in.-KGAVT0101BRA			3-in.-KGAVT0201BRA			
Concentric Vent Termination Kit (Single Exit)		2-in.-KGAVT0701CVT						
Condensate Freeze Protection Kit		KGAHT0101CFP						
Condensate Neutralizer Kit (Obtained Thru RCD)		P908-0001						
Side Filter Rack (Without Filter)-Upflow ONLY		KGAFR0206ALL						
Electronic/Mechanical Air Cleaner		Model EACA, EZXCAB, or FILCAB						
Humidifier		Model HUM						
Heat/Energy Recovery Ventilator		Model HRV						
UV Lights		Model UVL						
Door Gasket Kit		KGBAC0110DGK						
Unframed Filter Permanent Washable 3/4-in. (19 mm) thick 16 x 25 (406 x 635) 24 x 25 (610 x 635)		KGAWF1306UFR KGAWF1506UFR						

See notes at end of table.

58MXB

SPECIFICATIONS (CONTINUED)

UNIT SIZE		080-16	080-20	100-16	100-20	120-20	140-20	
RATINGS AND PERFORMANCE								
Input Btuh*		80,000	80,000	100,000	100,000	120,000	138,000	
Output Capacity BTUH* (ICS) (Shaded capacities are specified on rating plate)	Direct Vent (2-Pipe)	Upflow	75,000	75,000	94,000	94,000	113,000	129,000
		Downflow	75,000	75,000	94,000	94,000	113,000	129,000
		Horizontal	75,000	75,000	93,000	93,000	112,000	128,000
	Non-Direct Vent (1-Pipe)	Upflow	75,000	75,000	94,000	94,000	112,000	NA
		Downflow	75,000	75,000	93,000	93,000	113,000	NA
		Horizontal	75,000	75,000	93,000	93,000	112,000	NA
AFUE% Nonweatherized ICS	Direct Vent (2-Pipe)	Upflow	93.0					92.6
		Downflow	91.5					91.2
		Horizontal	92.3					92
	Non-Direct Vent (1-Pipe)	Upflow	92.4					NA
		Downflow	91.4					NA
		Horizontal	91.4					NA
Certified Temperature Rise Range ° F (° C)		30-60 (17-33)	20-50 (11-28)	45-75 (25-41)	30-60 (17-33)	40-70 (22-39)	50-80 (28-44)	
Certified External Static Pressure		Heating 0.15		0.20		0.20		
		Cooling 0.50		0.50		0.50		
Airflow CFM‡		Heating 1285		1315		1690		
		Cooling 1525		1925		2000		
ELECTRICAL								
Unit Volts-Hertz-Phase		115-60-1						
Operating Voltage Range Min-Max**		104-127						
Maximum Unit Amps		10.1	14.1	10.2	14.8	14.6	14.6	
Unit Ampacity††		13.4	18.4	13.5	19.3	19.1	18.8	
Minimum Wire Size		14	12	14	12	12	12	
Maximum Wire Length - Ft (M)‡‡		28 (8.5)	31 (9.4)	27 (8.2)	30 (9.1)	30 (9.1)	30 (9.1)	
Maximum Fuse Size or Ckt Bkr Amps (Time-Delay Type Recommended)		15	20	15	20	20	20	
Transformer (24v)		40va						
External Control Power Available		Heating		12va				
		Cooling		21va				
Air Conditioning Blower Relay		Standard						
CONTROLS								
Limit Control		SPST						
Heating Blower Control (Off Delay)		Selectable 90, 120, 150, or 180 Sec						
Burners (Monoport)		4	4	5	5	6	6	
Gas Connection Size		1/2-in. NPT						
GAS CONTROLS								
Gas Valve (Redundant)		Manufacturer		White-Rodgers				
		Min Inlet Pressure (In. wc)		4.5 (Natural Gas)				
		Max Inlet Pressure (In. wc)		13.6 (Natural Gas)				
Ignition Device		Hot Surface						
BLOWER DATA								
Direct-Drive Motor HP (Permanent Split Capacitor)		1/2	3/4	1/2	3/4	3/4	3/4	
Motor Full Load Amps		7.9	11.1	7.9	11.1	11.1	11.1	
RPM (Nominal)-Speeds		1075-4						
Blower Wheel Diameter x Width - In. (mm)		11 x 8 (279 x 203)	11 x 10 (279 x 254)	11 x 8 (279 x 203)	11 x 10 (279 x 254)	11 x 10 (279 x 254)	11 x 10 (279 x 254)	
Filter Size - In.(mm)		(1)16 x 25 x 3/4 (406 x 635 x 19)	(1) 20 x 25 x 3/4 (508 x 635 x 19)			(1)24 x 25 x 3/4 (610 x 635 x 19)		
FACTORY-AUTHORIZED AND LISTED, DEALER-INSTALLED OPTIONS								
Gas Conversion Kit-Natural-to-Propane		KGANP4601ALL						
Gas Conversion Kit-Propane-to-Natural		KGANP3901ALL						
Twinning Kit		KGATW0601HSI						
Manufactured (Mobile) Home Kit		KGAMH0301KIT						
Downflow Base***		KASB0301ALL						
Vent Termination Kit (Bracket Only for 2 Pipes)		2-in.-KGAVT0101BRA			3-in.-KGAVT0201BRA			
Concentric Vent Termination Kit (Single Exit)		2-in.-KGAVT0701CVT			3-in.-KGAVT0801CVT			
Condensate Freeze Protection Kit		KGAHT0101CFP						
Condensate Neutralizer Kit (Obtained Thru RCD)		P908-0001						
Side Filter Rack (Without Filter)-Upflow ONLY		KGAFR0206ALL						
Electronic/Mechanical Air Cleaner		Model EACB, EZXCAB, or FILCAB						
Humidifier		Model HUM						
Heat/Energy Recovery Ventilator		Model HRV						
UV Lights		Model UVL						
Door Gasket Kit		KGBAC0110DGGK						
Unframed Filter Permanent Washable 3/4-in. (19 mm) thick 16 x 25 (406 x 635) 24 x 25 (610 x 635)		KGAWF1306UFR KGAWF1506UFR						

* Gas input ratings are certified for elevations to 2000 ft. (610 M). For elevations above 2000 ft. (610 M), reduce ratings 2% for each 1000 ft. (305 M) above sea level. In Canada, derate the unit 5% from 2000 to 4500 ft. (610 to 1372 M) above sea level.

† Capacity and AFUE in accordance with U.S. Government DOE test procedures.

‡ Airflow shown is for bottom only return-air supply. Air delivery above 1800 CFM may require that both sides, a combination of 1 side and bottom, or bottom only of the furnace be used for return air, see Air Delivery table. Where 2 sets of data are listed, the first set is for bottom only return-air supply. The second set is for both sides, or 1 side and bottom return-air supply. A filter is required for each return-air supply.

** Permissible voltage limits for proper furnace operation.

†† Unit ampacity = 125% of largest component's full load amps plus 100% of all other potential operating components (EAC, humidifier, etc.).

‡‡ Length shown is measured 1 way along wire path between unit and service panel for maximum 2% voltage drop.

*** Required for installation on combustible floors when no coil box is used, or when any coil box other than a Carrier CD5, CK5, CAP(R), CNP(R), or KCAKC cased coil is used.

N/A - Not applicable

ICS - Isolated Combustion System

CONTROLS - THERMOSTATS AND ZONING

Non-Programmable Thermostat Section

TP–NAC, TC–NAC	For use with 1–speed Air Conditioner – deg. F/C, Auto Changeover
TP–NHP, TC–NHP	For use with 1 or 2–speed Heat Pumps – deg. F/C, Auto Changeover
TP–NRH†‡	For multi-use / stage configurations – deg. F/C, Auto Changeover/Temperature and Humidity Control

Programmable Thermostat Section

TC–PAC	For use with 1-speed Air Conditioner - deg. F/C, Auto Changeover, 7-Day Programmable
TC–PHP	For use with 1 or 2-speed Heat Pumps - deg. F/C, Auto Changeover, 5-2 Day Programmable
TP–PAC	For use with 1-speed Air Conditioner - deg. F/C, 7 Day Programmable
TP–PHP	For use with 1 or 2-speed Heat Pumps F/C, Auto Changeover, 7-Day Programmable
TP–PRH‡	For multi-use / stage configurations - deg. F/C, Auto Changeover, 7-Day Programmable/Temperature and Humidity Control

Zoning Control Selection

ZONECC3ZAC01 ZONECC3ZHP01	Zone Perfect Two–Zone kit
ZONECC2KIT01–B	Zone Perfect Plus 2–Zone kit/Temperature and Humidity Control
ZONECC4KIT01–B	Zone Perfect Plus 4–Zone kit/Temperature and Humidity Control
ZONECC8KIT01–B	Zone Perfect Plus 8–Zone kit/Temperature and Humidity Control

†Thermidistat™ Control control can be configured for multiple use and staging. It must be configured for each specific application.

‡HYBRID HEAT™ thermostat is used with furnace and heat pump application.

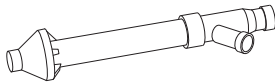

A93086

CONCENTRIC VENT (DIRECT VENT/ 2-PIPE ONLY)

A concentric vent kit allows vent and combustion-air pipes to terminate through a single exit in a roof or side wall.

One pipe runs inside the other allowing venting through the inner pipe and combustion air to be drawn in through the outer pipe.

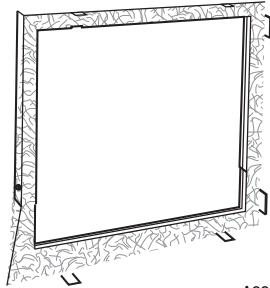

A88202

DOWNFLOW SUBBASE

One base fits all furnace sizes. The base is designed to be installed between the furnace and a combustible floor when no coil box is used or when a coil box other than a Carrier cased coil is used. It is CSA (A.G.A./C.G.A.) design certified for use with select Carrier furnaces when installed in downflow applications.

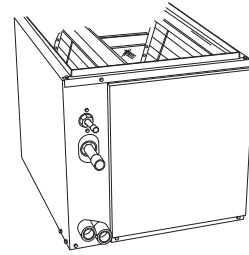

A96214

CARRIER CASED N-COIL (as shown)

The Carrier Cased N-Coil or A-Coil is an upflow/downflow furnace coil which can also replace the downflow subbase when installing select Carrier furnaces on combustible flooring in the downflow orientation.

A08449

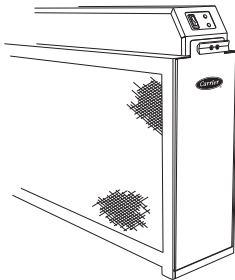

A97152

ELECTRONIC AIR CLEANER

Cleans the air of smoke, dirt, and many pollens commonly found. Saves decorating and cleaning expenses by keeping carpets, furniture, and drapes cleaner.

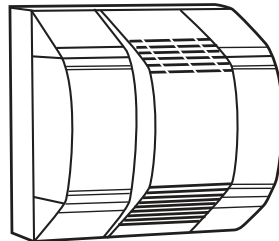

A01484

HUMIDIFIER

By adding moisture to winter-dry air, a Carrier humidifier can often improve comfort and keeps woodwork, wallpaper, and paint in better condition. Moisturizing household air also helps to retain normal body heat and provides comfort at lower temperatures.

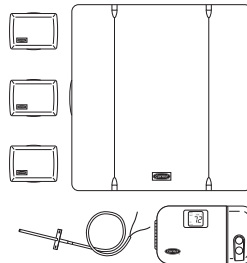

A97432

CONTROLS: THERMOSTATS AND ZONING

Available in programmable and non-programmable models, Carrier thermostats maintain a constant, comfortable temperature level in the home.

For the ultimate in home comfort, Carrier's 2, 4, and 8-zone systems allow temperature control of individual zones of the home. This is accomplished through a series of electronic dampers and remote room sensors. The 4-zone system is shown.

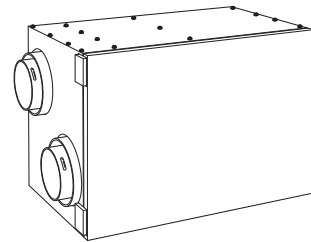

A94336

ENERGY/HEAT RECOVERY VENTILATOR

Carrier's energy or heat recovery ventilators exhaust stale indoor air and provide fresh outdoor air to the home while minimizing heat loss and humidity level. Especially useful for today's tighter constructed houses.

Energy recovery ventilator is shown.

A08152

DIMENSIONAL DRAWING

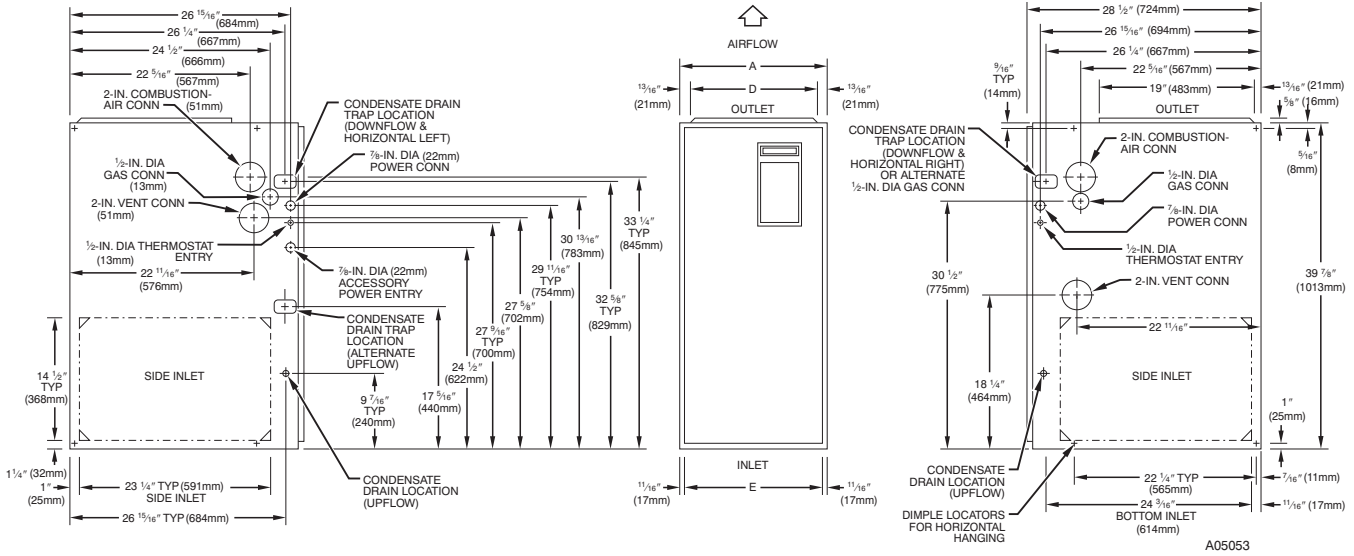

- NOTES:**
- Minimum return-air openings at furnace, based on metal duct. If flex duct is used, see flex duct manufacturer's recommendation for equivalent diameters.
 - Minimum return-air opening at furnace:
 - For 800 CFM 16-in. (406mm) round or 14 1/2 (368mm) x 12-in. (305mm) rectangle.
 - For 1200 CFM 20-in. (508mm) round or 14 1/2 (368mm) x 19 1/2-in. (495mm) rectangle.
 - For 1600 CFM 22-in. (559mm) round or 14 1/2 (368mm) x 23 1/2-in. (591mm) rectangle.
 - For airflow requirements above 1800 CFM, see Air Delivery table in Product Data literature for specific use of single side inlets. The use of both side inlets, a combination of 1 side and the bottom, or the bottom only will ensure adequate return air openings for airflow requirements above 1800 CFM at 0.5" W.C. ESP.

Dimensions – IN. (mm)

UNIT SIZE	A	D	E
040–08	17-1/2 (445)	15-7/8 (403)	16 (406)
040–12	17-1/2 (445)	15-7/8 (403)	16 (406)
060–08	17-1/2 (445)	15-7/8 (403)	16 (406)
060–12	17-1/2 (445)	15-7/8 (403)	16 (406)
060–16	17-1/2 (445)	15-7/8 (403)	16 (406)
080–12	17-1/2 (445)	15-7/8 (403)	16 (406)
080–16	17-1/2 (445)	15-7/8 (403)	16 (406)
080–20	21 (533)	19-3/8 (492)	19-1/2 (495)
100–16	21 (533)	19-3/8 (492)	19-1/2 (495)
100–20	21 (533)	19-3/8 (492)	19-1/2 (495)
120–20	24-1/2 (622)	22-7/8 (581)	23 (584)
140–20	24-1/2 (622)	22-7/8 (581)	23 (584)

58MXB

ACCESSORY DOWNFLOW SUBBASE

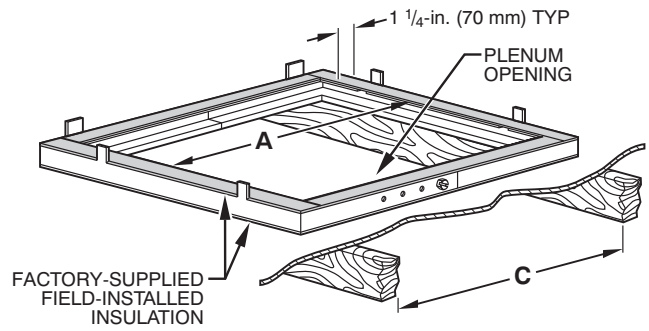
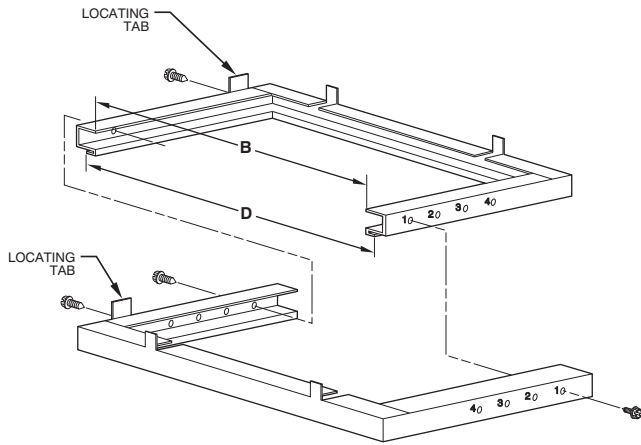

58MXB

Disassembled

A88207

Assembled

A97427

FURNACE CASING WIDTH IN. (mm)	FURNACE IN DOWNFLOW APPLICATION	PLENUM OPENING* IN. (mm)		FLOOR OPENING IN. (mm)		HOLE NO. FOR WIDTH ADJUSTMENT
		A	B	C	D	
17-1/2 (445 mm)	Furnace with or without Cased Coil Assembly or Coil Box	15-1/8 (384 mm)	19 (483 mm)	16-3/4 (426 mm)	20-3/8 (518 mm)	3
21 (533 mm)	Furnace with or without Cased Coil Assembly or Coil Box	18-5/8 (473 mm)	19 (483 mm)	20-1/4 (514 mm)	20-3/8 (518 mm)	2
24-1/2 (622 mm)	Furnace with or without Cased Coil Assembly or Coil Box	22-1/8 (562 mm)	19 (483 mm)	23-3/4 (603 mm)	20-3/8 (518 mm)	1

*The plenum should be constructed 1/4 in. (6 mm) smaller in width and depth than the plenum dimensions shown above.

COMBUSTION-AIR PIPE FOR NON-DIRECT VENT (1-PIPE) APPLICATION (SIZES 040 THROUGH 120 ONLY)

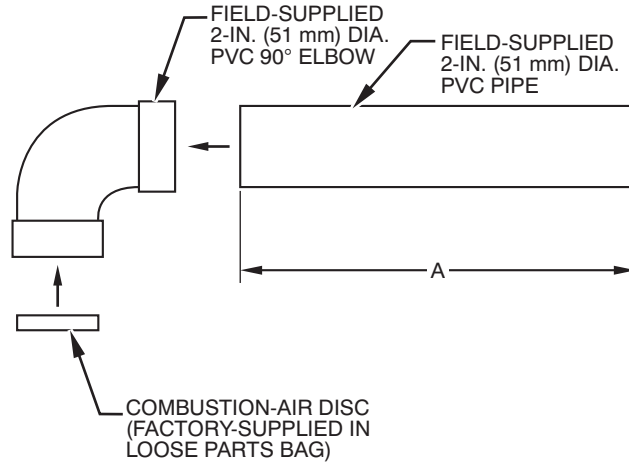

CASING WIDTH IN. (mm)	A IN. (mm)
17-1/2 (445)	8-1/2 ± 1/2 (216 ± 13)
21 (533)	10-1/2 ± 1/2 (267 ± 13)
24-1/2 (622)	12 ± 1/2 (305 ± 13)

A96211

58MXB

CONCENTRIC VENT FOR DIRECT VENT (2-PIPE) APPLICATION (ALL MODEL SIZES)

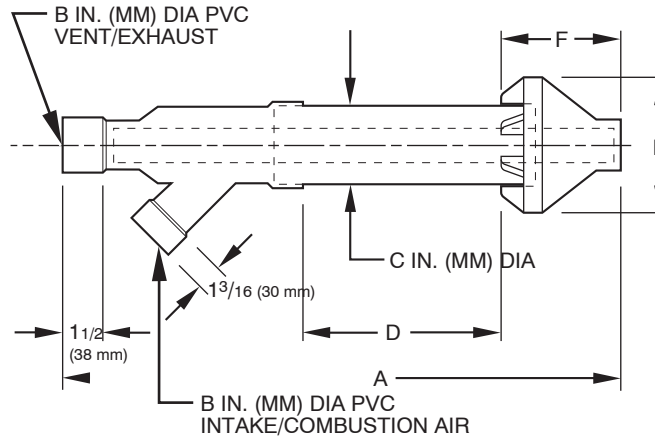

PART NO.	A*	B	C	D†	E	F
KGAVT0701CVT	33-3/8 (848)	2 (51)	3-1/2 (89)	16-5/8 (422)	6-1/4 (159)	5-3/4 (146)
KGAVT0801CVT	38-7/8 (987)	3 (76)	4-1/2 (114)	21-1/8 (537)	7-3/8 (187)	6-1/2 (165)

A97110

* Dimension A will change accordingly as dimension D is lengthened or shortened.

† Dimension D may be lengthened to 60 in. (1524 mm) maximum. Dimension D may also be shortened by cutting the pipes provided in the kit to 12 in. (305 mm) minimum.

NOTE: See furnace Installation Instructions when venting multiple furnaces near each other.

CONDENSATE TRAP

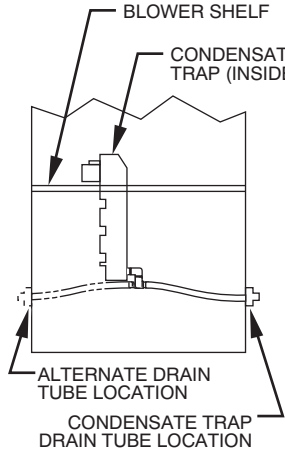

UPFLOW APPLICATIONS

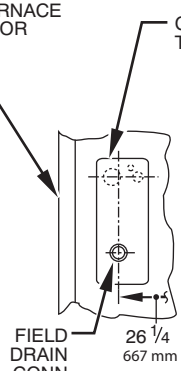

SIDE VIEW

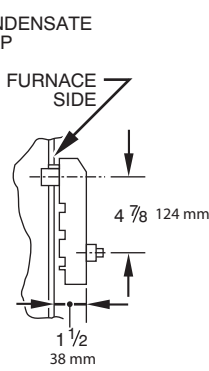

FRONT VIEW

DOWNFLOW AND ALTERNATE EXTERNAL UPFLOW APPLICATIONS

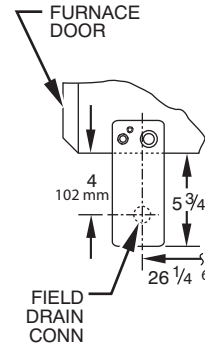

END VIEW

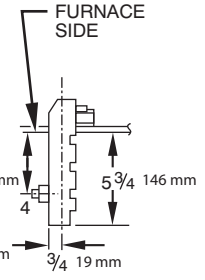

FRONT VIEW

HORIZONTAL APPLICATIONS

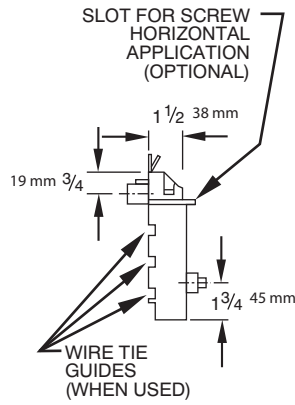

FRONT VIEW

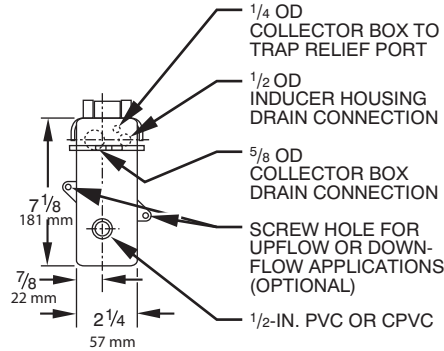

SIDE VIEW

58MxB

MEDIA FILTER CABINET

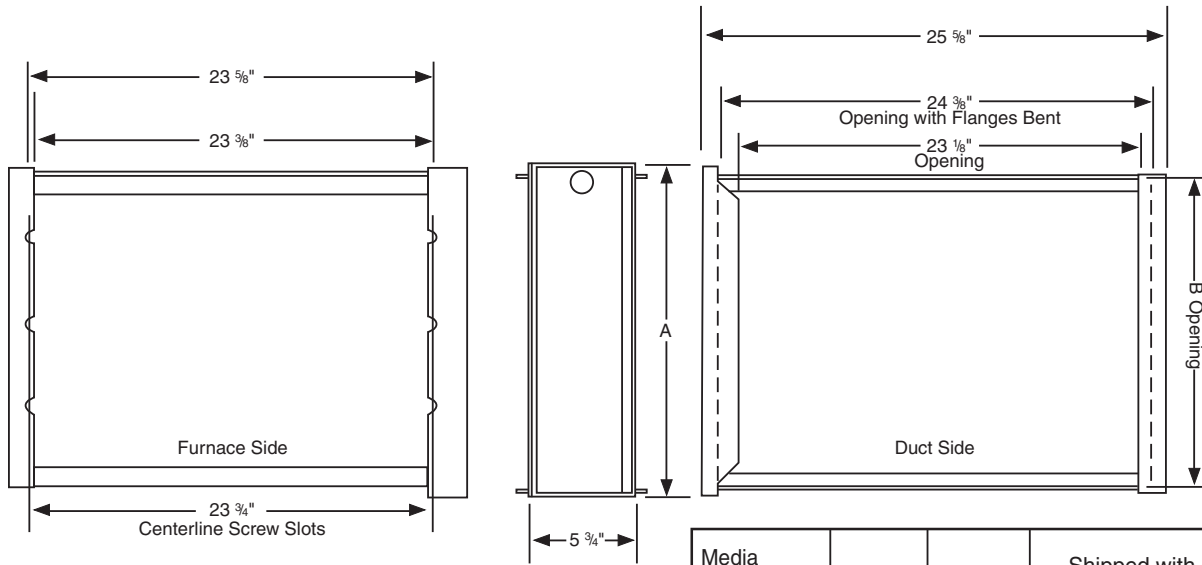

Media Filter Cabinet	A	B	Shipped with sizes
16"	17"	16"	024040, 036040, 024060, 036060, 048060, 036080, 048080
20"	21"	20"	060080, 048100, 060100
24"	25"	24"	060120, 060140

A05218

58MXB

CLEARANCE TO COMBUSTIBLES

INSTALLATION

- This forced air furnace is equipped for use with natural gas at altitudes 0 - 10,000 ft (0 - 3,050m), except 140 size furnaces are only approved for altitudes 0 - 7,000 ft (0 - 2,135m).
- An accessory kit, supplied by the manufacturer, shall be used to convert to propane gas use or may be required for some natural gas applications.
- This furnace is for indoor installation in a building constructed on site. This furnace may be installed in a manufactured (mobile) home when stated on rating plate and using factory authorized kit.
- This furnace may be installed on combustible flooring in alcove or closet at **Minimum Inches Clearance To Combustible Construction** as described below.
- This furnace requires a special venting system. Refer to the installation instructions for parts list and method of installation. In the US this furnace is for use with schedule-40 PVC, PVC-DWV, CPVC, or ABS-DWV pipe, and must not be vented in common with other gas-fired appliances. In Canada, refer to installation instructions for vent materials. Construction through which vent/air intake pipes may be installed is maximum 24 inches (610 mm), minimum 3/4 inches (19 mm) thickness (including roofing materials).
- Cette fournaise à air pulsé est équipée pour utilisation avec gaz naturel et altitudes comprises entre 0 - 3,050m (0 - 10,000 pi), excepté que les fournaises de 140 taille sont pour altitudes comprises entre 0 - 2,135m (0 - 7,000pi).
- Utiliser une trousse de conversion, fournie par le fabricant, pour passer au gaz propane ou pour certaines installations au gaz naturel.
- Cette fournaise à air pulsé est pour installation à l'intérieur dans un bâtiment construit sur place. Cette fournaise à air pulsé peut être installée dans une maison préfabriquée (maison mobile) si prescrit par la plaque signalétique et si l'on utilise une trousse spécifiée par le fabricant.
- Cette fournaise peut être installée sur un plancher combustible dans un enfoncement ou un placard en observant les **Dégagement Minimum En Pouces Avec Éléments De Construction Combustibles**.
- Cette fournaise nécessite un système d'évacuation spécial. La méthode d'installation et la liste des pièces nécessaires figurent dans les instructions d'installation. Aux États-Unis, cette fournaise doit s'utiliser avec la tuyauterie des nomenclatures 40 PVC, PVC-DWV, CPVC, ou ABS-DWV et elle ne peut pas être ventilée conjointement avec d'autres appareils à gaz. Au Canada, référer aux instructions d'installation pour les matériaux à ventiler. Épaisseur de la construction au travers de laquelle il est possible de faire passer les tuyaux d'aération (admission/évacuation): 24 po (610 mm) maximum, 3/4 po (19mm) minimum (y compris la toiture).

For upflow and downflow applications, furnace must be installed level, or pitched within 1/2" (12.7mm) of level. For a horizontal application, the furnace must be pitched minimum 1/4" (6.35mm) to maximum of 1/2" (12.7mm) forward for proper drainage. See Installation Manual for IMPORTANT unit support details on horizontal applications.

Pour des applications de flux ascendant et descendant, la fournaise doit être installée de niveau ou inclinée à pas plus de 1/2" (12.7mm) du niveau. Pour une application horizontale, la fournaise doit être inclinée entre minimum 1/4" (6.35mm) et maximum 1/2" (12.7mm) du niveau pour le drainage approprié. En cas d'installation en position horizontale, consulter les renseignements IMPORTANTS sur le support dans le manuel d'installation.

LEVEL 0" (0) TO
1/2" (12.7mm) MAX

MIN 1/4" (6.35mm) TO
1/2" (12.7mm) MAX

UPFLOW OR
DOWNFLOW

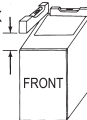

HORIZONTAL

MINIMUM INCHES CLEARANCE TO COMBUSTIBLE CONSTRUCTION

ALL POSITIONS:

- * Minimum front clearance for service 24 inches (610mm).
- †† 140 size furnaces require 1 inch back clearance to combustible materials.

DOWNFLOW POSITIONS:

- † For installation on combustible floors only when installed on special base No. KGASB0201ALL or NAHA01101SB, Coil Assembly, Part No. CAR, CAP, CNPV, CNRV or Coil Casing, Part No. KCAKC, or WENC or WTNC.

HORIZONTAL POSITIONS:

Line contact is permissible only between lines formed by intersections of top and two sides of furnace jacket, and building joists, studs, or framing.

- § Clearance shown is for air inlet and air outlet ends.
- Ø 120 and 140 size furnaces require 1 inch bottom clearance to combustible materials.

DÉGAGEMENT MINIMUM EN POUCES AVEC ÉLÉMENTS DE CONSTRUCTION COMBUSTIBLES

POUR TOUTS LES POSITIONS:

- * Dégagement avant minimum de 24 po (610mm) pour l'entretien.
- †† Pour les fournaises de 140 taille, 1 po (25mm) dégagement des matériaux combustibles est requis au-arrière.

POUR LA POSITION COURANT DESCENDANT:

- † Pour l'installation sur le plancher combustible seulement quand on utilise la base spéciale, pièce n° KGASB0201ALL ou NAHA01101SB, l'ensemble serpentin, pièce n° CAR, CAP, CNPV, CNRV, ou le carter de serpentin, pièce n° KCAKC ou WENC ou WTNC.

POUR LA POSITION HORIZONTALE:

Le contact n'est permis qu'entre les lignes formées par les intersections du dessus et des deux côtés de la chemise de la fournaise, et des solives, des montants ou de la charpente du bâtiment.

- § La distance indiquée concerne l'extrémité du tuyau d'arrivée d'air et l'extrémité du tuyau de sortie d'air.
- Ø Pour les fournaises de 120 et 140 taille, 1 po (25mm) dégagement des matériaux combustibles est requis au-dessous.

This furnace is approved for UPFLOW, DOWNFLOW and HORIZONTAL installations.

Cette fournaise est approuvée pour l'installation HORIZONTALE et la circulation d'air VERS LE HAUT et VERS LE BAS.

Clearance arrows do not change with furnace orientation.

Les flèches de dégagement ne change pas avec l'orientation de la générateur d'air chaud.

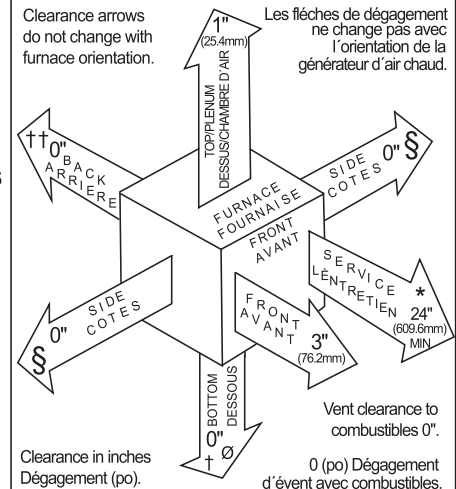

Clearance in inches
Dégagement (po).

Vent clearance to
combustibles 0".

0 (po) Dégagement
d'évent avec combustibles.

335122-201 REV. B LIT TOP

58MXB

A08435

AIR DELIVERY -CFM (WITH FILTER)*

UNIT SIZE	RETURN-AIR SUPPLY	SPEED	EXTERNAL STATIC PRESSURE (In. wc)							
			0.1	0.2	0.3	0.4	0.5	0.6	0.7	0.8
040-08	1 side or bottom	High	1075	1040	995	945	895	840	760	670
		Med-Low	850	825	780	740	685	635	560	480
		Low	740	700	650	620	565	515	455	385
040-12	1 side or bottom	High	1470	1415	1400	1285	1215	1120	995	890
		Med-High	1315	1280	1235	1180	1115	1035	930	825
		Med-Low	1125	1110	1085	1045	990	915	830	740
060-08	1 side or bottom	High	1100	1065	1005	945	900	805	730	610
		Med-Low	890	865	810	765	705	620	540	475
		Low	745	710	670	625	565	505	425	360
060-12	1 side or bottom	High	1430	1375	1325	1275	1200	1135	1040	935
		Med-High	1270	1260	1215	1160	1105	1035	950	850
		Med-Low	1070	1055	1045	1015	975	920	850	750
060-16	1 side or bottom	High	1700	1695	1640	1580	1545	1450	1380	1310
		Med-High	1500	1465	1435	1385	1355	1300	1250	1185
		Med-Low	1325	1295	1265	1230	1190	1150	1105	1050
080-12	1 side or bottom	High	1535	1470	1405	1330	1245	1160	1065	935
		Med-High	1395	1350	1300	1225	1155	1080	985	880
		Med-Low	1200	1175	1125	1065	1030	970	890	780
080-16	1 side or bottom	High	1750	1685	1635	1575	1525	1445	1380	1310
		Med-High	1495	1455	1405	1355	1305	1250	1185	1120
		Med-Low	1310	1260	1225	1170	1125	1095	1040	980
080-20	1 side or bottom	High	2200	2175	2085	2025	1925	1820	1735	1635
		Med-High	2100	2025	1945	1865	1785	1700	1620	1540
		Med-Low	1815	1760	1720	1670	1620	1550	1480	1405
100-16	1 side or bottom	High	1740	1705	1660	1615	1570	1500	1425	1355
		Med-High	1500	1470	1445	1410	1375	1330	1280	1210
		Med-Low	1340	1315	1300	1270	1235	1200	1140	1095
100-20	1 side or bottom	High	2250	2175	2090	2020	1930	1855	1760	1670
		Med-High	2020	1950	1900	1840	1790	1710	1640	1545
		Med-Low	1725	1690	1660	1630	1575	1520	1460	1370
120-20	bottom only	High	2350	2250	2160	2070	2000	1885	1790	1635
		Med-High	2100	2015	1955	1875	1810	1710	1650	1540
		Med-Low	1770	1720	1675	1620	1575	1515	1450	1365
140-20	both sides or 1 side and bottom	High	2435	2360	2285	2220	2130	2050	1965	1875
		Med-High	2040	2000	1950	1905	1835	1790	1725	1650
		High	2255	2190	2115	2045	1965	1890	1800	1710
140-20	1 side only	Med-High	1985	1930	1890	1840	1780	1720	1645	1560
		High	2285	2210	2140	2065	1990	1910	1830	1745
		Med-High	2020	1970	1920	1870	1805	1730	1660	1590
140-20	both sides or 1 side and bottom	Med-Low	1675	1650	1620	1590	1560	1510	1450	1390
		Low	1460	1445	1430	1400	1370	1320	1275	1230
		High	2310	2255	2185	2120	2045	1965	1880	1800
140-20	1 side only	Med-High	1975	1945	1900	1860	1835	1775	1720	1640
		High	2140	2080	2025	1945	1875	1795	1725	1625
		Med-High	1930	1850	1800	1740	1725	1660	1580	1495

58MXB

* – Airflow shown is for bottom only return –air supply width 3/4" (19 mm) washable filter(s). A filter is required for each return –air supply.
 – For air delivery above 1800 CFM, see Air Delivery table for other options.
 – An airflow reduction of up to 7% may occur when using the factory –specified 4 5/16 –in. (110 mm) wide, high efficiency media filter.
 – For best furnace efficiency when using the 4 5/16 –in. (110 mm) wide media filter, adjust the blower speed tap to near the mid –point of the rise range.
 – For horizontal and downflow applications, use "1 side or bottom" or "bottom only" as an airflow reference.

MAXIMUM ALLOWABLE PIPE LENGTH - FT. (M)

58MXB

ALTITUDE FT. (M)	UNIT SIZE (BTUH)	DIRECT VENT (2-PIPE) ONLY		NON-DIRECT VENT (1-PIPE) ONLY	NUMBER OF 90° ELBOWS						
		TERMINATION TYPE	PIPE DIA IN. (mm)*	PIPE DIA IN. (mm)*	1	2	3	4	5	6	
0 to 2000 (0 to 610)	40,000	2 Pipe or 2-in. (51 mm) Concentric	1 (25)	1 (25)	5 (1.5)	NA	NA	NA	NA	NA	NA
			1-1/2 (38)	1-1/2 (38)	70 (21.3)	70 (21.3)	65 (19.8)	60 (18.3)	60 (18.3)	55 (16.8)	
			2 (51)	2 (51)	70 (21.3)	70 (21.3)	70 (21.3)	70 (21.3)	70 (21.3)	70 (21.3)	70 (21.3)
	60,000	2 Pipe or 2-in. (51 mm) Concentric	1-1/2 (38)	1-1/2 (38)	20 (6.1)	15 (4.6)	10 (3.0)	5 (1.5)	NA	NA	NA
			2 (51)	2 (51)	70 (21.3)	70 (21.3)	70 (21.3)	70 (21.3)	70 (21.3)	70 (21.3)	70 (21.3)
	80,000	2 Pipe or 2-in. (51 mm) Concentric	1-1/2 (38)	1-1/2 (38)	10 (3.0)	NA	NA	NA	NA	NA	NA
			2 (51)	2 (51)	55 (16.8)	50 (15.2)	35 (10.7)	30 (9.1)	30 (9.1)	20 (6.1)	
			2-1/2 (64)	2-1/2 (64)	70 (21.3)	70 (21.3)	70 (21.3)	70 (21.3)	70 (21.3)	70 (21.3)	70 (21.3)
	100,000	2 Pipe or 3-in. (76 mm) Concentric	2 (51)	2 (51)	5 (1.5)	NA	NA	NA	NA	NA	NA
			2-1/2 (64)	2-1/2 (64)	40 (12.2)	30 (9.1)	20 (6.1)	20 (6.1)	10 (3.0)	NA	
			3 (76)	3 (76)	70 (21.3)	70 (21.3)	70 (21.3)	70 (21.3)	70 (21.3)	70 (21.3)	70 (21.3)
	120,000	2 Pipe or 3-in. (76 mm) Concentric	2-1/2 (64) one disk	2-1/2 (64)	10 (3.0)	NA	NA	NA	NA	NA	NA
			3 (76)†	NA	45 (13.7)	40 (12.2)	35 (10.7)	30 (9.1)	25 (7.6)	20 (6.1)	
			3 (76) † no disk	3 (76)†	70 (21.3)	70 (21.3)	70 (21.3)	70 (21.3)	70 (21.3)	70 (21.3)	70 (21.3)
	140,000	2 Pipe or 3-in. (76 mm) Concentric	2-1/2 (64) one disk	NA	5 (1.5)	NA	NA	NA	NA	NA	NA
			3 (76)†	NA	40 (12.1)	35 (10.6)	30 (9.1)	25 (7.6)	20 (6.1)	15 (4.6)	
			3 (76) † no disk	NA	60 (18.3)	56 (17.0)	52 (15.8)	48 (14.6)	44 (13.4)	40 (12.2)	
			4 (102) † no disk	NA	70 (21.3)	70 (21.3)	70 (21.3)	70 (21.3)	70 (21.3)	70 (21.3)	70 (21.3)
	ALTITUDE FT. (M)	UNIT SIZE (BTUH)	DIRECT VENT (2-PIPE) ONLY		NON-DIRECT VENT (1-PIPE) ONLY	NUMBER OF 90° ELBOWS					
			TERMINATION TYPE	PIPE DIA IN. (mm)*	PIPE DIA IN. (mm)*	1	2	3	4	5	6
2001 to 3000 (610 to 914) Canada	40,000	2 Pipe or 2-in. (51 mm) Concentric	1-1/2 (38)	1-1/2 (38)	67 (20.4)	62 (18.9)	57 (17.4)	52 (15.8)	52 (15.8)	47 (14.3)	
			2 (51)	2 (51)	70 (21.3)	70 (21.3)	70 (21.3)	70 (21.3)	70 (21.3)	70 (21.3)	
	60,000	2 Pipe or 2-in. (51 mm) Concentric	1-1/2 (38)	1-1/2 (38)	17 (5.2)	12 (3.7)	7 (2.1)	NA	NA	NA	
			2 (51)	2 (51)	70 (21.3)	67 (20.4)	66 (20.1)	61 (18.6)	61 (18.6)	61 (18.6)	
	80,000	2 Pipe or 2-in. (51 mm) Concentric	2 (51)	2 (51)	49 (14.9)	44 (13.4)	30 (9.1)	25 (7.6)	25 (7.6)	15 (4.6)	
			2-1/2 (64)	2-1/2 (64)	70 (21.3)	70 (21.3)	70 (21.3)	70 (21.3)	70 (21.3)	70 (21.3)	
	100,000	2 Pipe or 3-in. (76 mm) Concentric	2-1/2 (64)	2-1/2 (64)	35 (10.7)	26 (7.9)	16 (4.9)	16 (4.9)	6 (1.8)	NA	
			3 (76)	3 (76)	70 (21.3)	70 (21.3)	70 (21.3)	70 (21.3)	66 (20.1)	61 (18.6)	
	120,000	2 Pipe or 3-in. (76 mm) Concentric	3 (76)	NA	14 (4.3)	9 (2.7)	NA	NA	NA	NA	
			NA	3 (76)†	63 (19.2)	62 (18.9)	62 (18.9)	61 (18.6)	61 (18.6)	61 (18.6)	
			3 (76) † no disk	NA	70 (21.3)	70 (21.3)	63 (19.2)	56 (17.1)	50 (15.2)	43 (13.1)	
			4 (102)† no disk	4 (102)† no disk	70 (21.3)	70 (21.3)	70 (21.3)	70 (21.3)	70 (21.3)	70 (21.3)	70 (21.3)
	140,000	2 Pipe or 3-in. (76 mm) Concentric	3 (76) one disk†	NA	20 (6.1)	15 (4.6)	10 (3.0)	5 (1.5)	NA	NA	
			3 (76) † no disk	NA	39 (11.8)	35 (10.6)	31 (11.9)	27 (8.2)	23 (7.0)	19 (5.8)	
			4 (102)† no disk	NA	70 (21.3)	70 (21.3)	70 (21.3)	70 (21.3)	70 (21.3)	70 (21.3)	

See notes at end of table.

MAXIMUM ALLOWABLE PIPE LENGTH - FT. (M) (CONTINUED)

ALTITUDE FT. (M)	UNIT SIZE (BTUH)	DIRECT VENT (2-PIPE) ONLY		NON-DIRECT VENT (1-PIPE) ONLY	NUMBER OF 90° ELBOWS					
		TERMINATION TYPE	PIPE DIA – IN (mm)*	PIPE DIA – IN (mm)*	1	2	3	4	5	6
3001 to 4000 (914 to 1219)	40,000	2 Pipe or 2-in. (51 mm) Concentric	1-1/2 (38)	1-1/2 (38)	64 (19.5)	59 (18.0)	54 (16.5)	49 (14.9)	48 (14.6)	43 (13.1)
			2 (51)	2 (51)	70 (21.3)	70 (21.3)	70 (21.3)	70 (21.3)	70 (21.3)	70 (21.3)
	60,000	2 Pipe or 2-in. (51 mm) Concentric	1-1/2 (38)	1-1/2 (38)	16 (4.9)	11 (3.4)	6 (1.8)	NA	NA	NA
			2 (51)	2 (51)	68 (20.7)	63 (19.2)	62 (18.9)	57 (17.4)	57 (17.4)	56 (17.1)
	80,000	2 Pipe or 2-in. (51 mm) Concentric	2 (51)	2 (51)	46 (14.0)	41 (12.5)	28 (8.5)	23 (7.0)	22 (6.7)	13 (4.0)
			2-1/2 (64)	2-1/2 (64)	70 (21.3)	70 (21.3)	70 (21.3)	70 (21.3)	70 (21.3)	70 (21.3)
	100,000	2 Pipe or 3-in. (76 mm) Concentric	2-1/2 (64)	2-1/2 (64)	33 (10.1)	24 (7.3)	15 (4.6)	14 (4.3)	5 (1.5)	NA
			3 (76)	3 (76)	70 (21.3)	70 (21.3)	70 (21.3)	66 (20.1)	61 (18.6)	56 (17.1)
	120,000	2 Pipe or 3-in. (76 mm) Concentric	3 (76)† no disk	NA	65 (19.8)	58 (17.7)	51 (15.5)	44 (13.4)	38 (11.6)	31 (9.4)
			NA	3 (76)†	59 (18.0)	59 (18.0)	58 (17.7)	57 (17.4)	57 (17.4)	56 (17.1)
		4† no disk	4 (102)† no disk	4 (102) † no disk	70 (21.3)	70 (21.3)	70 (21.3)	70 (21.3)	70 (21.3)	70 (21.3)
	140,000	2 Pipe or 3-in. (76 mm) Concentric	3 (76) one disk†	NA	11 (3.4)	6 (1.8)	NA	NA	NA	NA
			3 (76)† no disk	NA	30 (9.1)	26 (7.9)	22 (6.7)	18 (5.5)	14 (4.3)	10 (3.0)
			4 (102)† no disk	NA	70 (21.3)	70 (21.3)	70 (21.3)	70 (21.3)	70 (21.3)	70 (21.3)
ALTITUDE FT. (M)	UNIT SIZE (BTUH)	DIRECT VENT (2-PIPE) ONLY		NON-DIRECT VENT (1-PIPE) ONLY	NUMBER OF 90° ELBOWS					
		TERMINATION TYPE	PIPE DIA IN. (mm)*	PIPE DIA IN. (mm)*	1	2	3	4	5	6
4001 to 5000† (1219 to 1524)	40,000	2 Pipe or 2-in. (51 mm) Concentric	1-1/2 (38)	1-1/2 (38)	60 (18.3)	55 (16.8)	50 (15.2)	45 (13.7)	44 (13.4)	39 (11.9)
			2 (51)	2 (51)	70 (21.3)	70 (21.3)	70 (21.3)	70 (21.3)	70 (21.3)	70 (21.3)
	60,000	2 Pipe or 2-in. (51 mm) Concentric	1-1/2 (38)	1-1/2 (38)	15 (4.6)	10 (3.0)	5 (1.5)	NA	NA	NA
			2 (51)	2 (51)	64 (19.5)	59 (18.0)	58 (17.7)	53 (16.2)	52 (15.8)	52 (15.8)
	80,000	2 Pipe or 2-in. (51 mm) Concentric	2 (51)	2 (51)	44 (13.4)	39 (11.9)	26 (7.9)	21 (6.4)	20 (6.1)	11 (3.4)
			2-1/2 (64)	2-1/2 (64)	70 (21.3)	70 (21.3)	70 (21.3)	70 (21.3)	70 (21.3)	70 (21.3)
	100,000	2 Pipe or 3-in. (76 mm) Concentric	2-1/2 (64)	2-1/2 (64)	31 (9.4)	22 (6.7)	13 (4.0)	12 (3.7)	NA	NA
			3 (76)	3 (76)	70 (21.3)	70 (21.3)	67 (20.4)	62 (18.9)	57 (17.4)	52 (15.8)
	120,000	2 Pipe or 3-in. (76 mm) Concentric	3 (76)† no disk	NA	53 (16.2)	46 (14.0)	40 (12.2)	33 (10.1)	26 (7.9)	20 (6.1)
			NA	3 (76)†	56 (17.1)	55 (16.8)	54 (16.5)	53 (16.2)	52 (15.8)	52 (15.8)
			4 (102)† no disk	4 (102)† no disk	70 (21.3)	70 (21.3)	70 (21.3)	70 (21.3)	70 (21.3)	70 (21.3)
	140,000	2 Pipe or 3-in. (76 mm) Concentric	3 (76)† no disk	NA	21 (6.4)	17 (5.1)	13 (3.9)	9 (2.7)	5 (1.5)	NA
			4 (102)† no disk	NA	69 (21.0)	64 (19.5)	59 (17.9)	54 (16.4)	49 (15.0)	44 (13.4)

See notes at end of table.

58MXB

MAXIMUM ALLOWABLE PIPE LENGTH - FT. (M) (CONTINUED)

58MXB

ALTITUDE FT. (M)	UNIT SIZE (BTUH)	DIRECT VENT (2-PIPE) ONLY		NON-DIRECT VENT (1-PIPE) ONLY	NUMBER OF 90° ELBOWS					
		TERMINATION TYPE	PIPE DIA IN. (mm)*	PIPE DIA IN. (mm)*	1	2	3	4	5	6
5001 to 6000† (1524 to 1829)	40,000	2 Pipe or 2-in. (51 mm) Concentric	1-1/2 (38)	1-1/2 (38)	57 (17.4)	52 (15.8)	47 (14.3)	42 (12.8)	40 (12.2)	35 (10.7)
			2 (51)	2 (51)	70 (21.3)	70 (21.3)	70 (21.3)	70 (21.3)	70 (21.3)	70 (21.3)
	60,000	2 Pipe or 2-in. (51 mm) Concentric	1-1/2 (38)	1-1/2 (38)	14 (4.3)	9 (2.7)	NA	NA	NA	NA
			2 (51)	2 (51)	60 (18.3)	55 (16.8)	54 (16.5)	49 (14.9)	48 (14.6)	47 (14.3)
	80,000	2 Pipe or 2-in. (51 mm) Concentric	2 (51)	2 (51)	41 (12.5)	36 (11.0)	23 (7.0)	18 (5.5)	17 (5.2)	8 (2.4)
			2-1/2 (64)	2-1/2 (64)	70 (21.3)	70 (21.3)	70 (21.3)	70 (21.3)	70 (21.3)	70 (21.3)
	100,000	2 Pipe or 3-in. (76 mm) Concentric	2-1/2 (64)	2-1/2 (64)	29 (8.8)	21 (6.4)	12 (3.7)	11 (3.4)	NA	NA
			3 (76)	3 (76)	70 (21.3)	67 (20.4)	62 (18.9)	57 (17.4)	52 (15.8)	47 (14.3)
	120,000	2 Pipe or 3-in. (76 mm) Concentric	3 (76)† no disk	NA	42 (12.8)	35 (10.7)	29 (8.8)	22 (6.7)	15 (4.6)	9 (2.7)
			NA	3 (76)†	53 (16.2)	52 (15.8)	50 (15.2)	49 (14.9)	48 (14.6)	47 (14.3)
			4 (102)† no disk	4 (102)† no disk	70 (21.3)	70 (21.3)	70 (21.3)	70 (21.3)	70 (21.3)	70 (21.3)
	140,000	2 Pipe or 3-in. (76 mm) Concentric	3 (76)† no disk	NA	12 (3.6)	8 (2.4)	NA	NA	NA	NA
			4 (102)† no disk	NA	42 (12.8)	37 (11.2)	32 (9.7)	27 (8.2)	22 (6.7)	17 (5.1)
	ALTITUDE FT. (M)	UNIT SIZE (BTUH)	DIRECT VENT (2-PIPE) ONLY		NON-DIRECT VENT (1-PIPE) ONLY	NUMBER OF 90° ELBOWS				
TERMINATION TYPE			PIPE DIA IN. (mm)*	PIPE DIA IN. (mm)*	1	2	3	4	5	6
6001 to 7000† (1829 to 2134)	40,000	2 Pipe or 2-in. (51 mm) Concentric	1-1/2 (38)	1-1/2 (38)	53 (16.2)	48 (14.6)	43 (13.1)	38 (11.6)	37 (11.3)	32 (9.8)
			2 (51)	2 (51)	70 (21.3)	70 (21.3)	68 (20.7)	67 (20.4)	66 (20.1)	64 (19.5)
	60,000	2 Pipe or 2-in. (51 mm) Concentric	1-1/2 (38)	1-1/2 (38)	13 (4.0)	8 (2.4)	NA	NA	NA	NA
			2 (51)	2 (51)	57 (17.4)	52 (15.8)	50 (15.2)	45 (13.7)	44 (13.4)	43 (13.1)
	80,000	2 Pipe or 2-in. (51 mm) Concentric	2 (51)	2 (51)	38 (11.6)	33 (10.1)	21 (6.4)	16 (4.9)	15 (4.6)	6 (1.8)
			2-1/2 (64)	2-1/2 (64)	70 (21.3)	70 (21.3)	68 (20.7)	67 (20.4)	66 (20.1)	64 (19.5)
	100,000	2 Pipe or 3-in. (76 mm) Concentric	2-1/2 (64)	2-1/2 (64)	27 (8.2)	19 (5.8)	10 (3.0)	9 (2.7)	NA	NA
			3 (76)	3 (76)	68 (20.7)	63 (19.2)	58 (17.7)	53 (16.2)	48 (14.6)	43 (13.1)
	120,000	2 Pipe or 3-in. (76 mm) Concentric	3 (76)† no disk	NA	31 (9.4)	24 (7.3)	18 (5.5)	11 (3.4)	NA	NA
			NA	3 (76)†	49 (14.9)	48 (14.6)	47 (14.3)	45 (13.7)	44 (13.4)	43 (13.1)
	140,000	2 Pipe or 3-in. (76 mm) Concentric	4 (102)† no disk	NA	17 (5.1)	12 (3.6)	7 (2.1)	NA	NA	NA

See notes at end of table.

MAXIMUM ALLOWABLE PIPE LENGTH - FT. (M) (CONTINUED)

ALTITUDE FT. (M)	UNIT SIZE (BTUH)	DIRECT VENT (2-PIPE) ONLY		NON-DIRECT VENT (1-PIPE) ONLY	NUMBER OF 90° ELBOWS					
		TERMINATION TYPE	PIPE DIA IN. (mm)*	PIPE DIA IN. (mm)*	1	2	3	4	5	6
7001 to 8000‡ (2134 to 2438)	40,000	2 Pipe or 2-in. (51 mm) Concentric	1-1/2 (38)	1-1/2 (38)	49 (14.9)	44 (13.4)	39 (11.9)	34 (10.4)	33 (10.1)	28 (6.5)
			2 (51)	2 (51)	66 (20.1)	65 (19.8)	63 (19.2)	62 (18.9)	60 (18.3)	59 (18.0)
	60,000	2 Pipe or 2-in. (51 mm) Concentric	1-1/2 (38)	1-1/2 (38)	12 (3.7)	7 (2.1)	NA	NA	NA	NA
			2 (51)	2 (51)	53 (16.2)	48 (14.6)	46 (14.0)	41 (12.5)	40 (12.2)	38 (11.6)
	80,000	2 Pipe or 2-in. (51 mm) Concentric	2 (51)	2 (51)	36 (11.0)	31 (9.4)	19 (5.8)	14 (4.3)	12 (3.7)	NA
			2-1/2 (64)	2-1/2 (64)	66 (20.1)	65 (19.8)	63 (19.2)	62 (18.9)	60 (18.3)	59 (18.0)
	100,000	2 Pipe or 3-in. (76 mm) Concentric	2-1/2 (64)	2-1/2 (64)	25 (7.6)	17 (5.2)	8 (2.4)	7 (2.1)	NA	NA
			3 (76)	3 (76)	63 (19.2)	58 (17.7)	53 (16.2)	48 (14.6)	43 (13.1)	38 (11.6)
	120,000	2 Pipe or 3-in. (76 mm) Concentric	3 (76)† no disk	NA	20 (6.1)	13 (4.0)	7 (2.1)	NA	NA	NA
			NA	3 (76)†	46 (14.0)	44 (13.4)	43 (13.1)	41 (12.5)	40 (12.2)	38 (11.6)
4 (102)† no disk			4 (102)† no disk	61 (18.6)	56 (17.1)	51 (15.5)	46 (14.0)	41 (12.5)	36 (11.0)	
140,000	NA									
ALTITUDE FT. (M)	UNIT SIZE (BTUH)	DIRECT VENT (2-PIPE) ONLY		NON-DIRECT VENT (1-PIPE) ONLY	NUMBER OF 90° ELBOWS					
		TERMINATION TYPE	PIPE DIA IN. (mm)*	PIPE DIA IN. (mm)*	1	2	3	4	5	6
8001 to 9000‡ (2438 to 2743)	40,000	2 Pipe or 2-in. (51 mm) Concentric	1-1/2 (38)	1-1/2 (38)	46 (14.0)	41 (12.5)	36 (11.0)	31 (9.4)	29 (8.8)	24 (7.3)
			2 (51)	2 (51)	62 (18.9)	60 (18.3)	58 (17.7)	56 (17.1)	55 (16.8)	53 (16.2)
	60,000	2 Pipe or 2-in. (51 mm) Concentric	1-1/2 (38)	1-1/2 (38)	11 (3.4)	6 (1.8)	NA	NA	NA	NA
			2 (51)	2 (51)	49 (14.9)	44 (13.4)	42 (12.8)	37 (11.3)	35 (10.7)	34 (10.4)
	80,000	2 Pipe or 2-in. (51 mm) Concentric	2 (51)	2 (51)	33 (10.1)	28 (8.5)	17 (5.2)	12 (3.7)	10 (3.0)	NA
			2-1/2 (64)	2-1/2 (64)	62 (18.9)	60 (18.3)	58 (17.7)	56 (17.1)	55 (16.8)	53 (16.2)
	100,000	2 Pipe or 3-in. (76 mm) Concentric	2-1/2 (64)	2-1/2 (64)	23 (7.0)	15 (4.6)	7 (2.1)	5 (1.5)	NA	NA
			3 (76)	3 (76)	59 (18.0)	54 (16.5)	49 (14.9)	44 (13.4)	39 (11.9)	34 (10.4)
	120,000	2 Pipe or 3-in. (76 mm) Concentric	3 (76)† no disk	NA	10 (3.0)	NA	NA	NA	NA	NA
			NA	3 (76)†	43 (13.1)	41 (12.5)	39 (11.9)	37 (11.3)	35 (10.7)	34 (10.4)
4 (102)† no disk			4† no disk	35 (10.7)	30 (9.1)	25 (7.6)	20 (6.1)	15 (4.6)	10 (3.0)	
140,000	NA									

See notes at end of table.

58MXB

MAXIMUM ALLOWABLE PIPE LENGTH - FT. (M) (CONTINUED)

58MXB

ALTITUDE FT. (M)	UNIT SIZE (BTUH)	DIRECT VENT (2-PIPE) ONLY		NON-DIRECT VENT (1-PIPE) ONLY	NUMBER OF 90° ELBOWS					
		TERMINATION TYPE	PIPE DIA IN. (mm)*	PIPE DIA IN. (mm)*	1	2	3	4	5	6
9001 to 10,000‡ (2743 to 3048)	40,000	2 Pipe or 2-in. (51 mm)	1-1/2 (38)	1-1/2 (38)	42 (12.8)	37 (11.3)	32 (9.8)	27 (8.2)	25 (7.6)	20 (6.1)
		Concentric	2 (51)	2 (51)	57 (17.4)	55 (16.8)	53 (16.2)	51 (15.5)	49 (14.9)	47 (14.3)
	60,000	2 Pipe or 2-in. (51 mm) Concentric	2 (51)	2 (51)	45 (13.7)	40 (12.2)	38 (11.6)	33 (10.1)	31 (9.4)	29 (8.8)
			2 (51)	2 (51)	30 (9.1)	25 (7.6)	14 (4.3)	9 (2.7)	7 (2.1)	NA
	80,000	2 Pipe or 2-in. (51 mm) Concentric	2-1/2 (64)	2-1/2 (64)	57 (17.4)	55 (16.8)	53 (16.2)	51 (15.5)	49 (14.9)	47 (14.3)
			2-1/2 (64)	2-1/2 (64)	21 (6.4)	13 (4.0)	5 (1.5)	NA	NA	NA
	100,000	2 Pipe or 3-in. (76 mm) Concentric	3 (76)	3 (76)	54 (16.5)	49 (14.9)	44 (13.4)	39 (11.9)	34 (10.4)	29 (8.8)
			NA	3 (76)†	39 (11.9)	37 (11.3)	35 (10.7)	33 (10.1)	31 (9.4)	29 (8.8)
	120,000	2 Pipe or 3-in. (76 mm) Concentric	4 (102)† no disk	4 (102)† no disk	10 (3.0)	5 (1.5)	NA	NA	NA	NA
			NA							
140,000	NA									

* Disk usage-Unless otherwise specified, use perforated disk assembly (factory-supplied in loose parts bag).

If one disk is stated, separate 2 halves of perforated disk assembly and use shouldered disk half. When using shouldered disk half, install screen side toward inlet box.

† Wide radius elbow.

‡ Vent sizing for Canadian installations over 4500 ft. (1370 M) above sea level are subject to acceptance by the local authorities having jurisdiction. NA-Not Allowed; pressure switch will not make.

NOTES:

1. Do not use pipe size greater than those specified in table or incomplete combustion, flame disturbance, or flame sense lockout may occur.
2. Size both the combustion-air and vent pipe independently, then use the larger diameter for both pipes.
3. Assume two 45° elbows equal one 90° elbow. Wide radius elbows are desirable and may be required in some cases.
4. Elbows and pipe sections within the furnace casing and at the vent termination should not be included in vent length or elbow count.
5. The minimum pipe length is 5 ft. (1.5 M) for all applications.
6. Use 3-in. (76 mm) diameter vent termination kit for installations requiring 4-in (102 mm) diameter pipe.

VENT LENGTH FOR OUTLET RESTRICTOR USAGE (60,000 BTU MODEL ONLY) - FT. (M)

ALTITUDE - FT. (M)	UNIT SIZE	DIRECT VENT (2-PIPE)	NON-DIRECT VENT (1-PIPE ONLY)	NO. OF 90° ELBOWS				
		PIPE DIA. (IN / mm)	PIPE DIA. (IN / mm)	1	2	3	4	5
0 – 2000 (0 – 610)	60,000	2-in. (51)	2-in. (51)	28 (8.5)	20 (6)	15 (4.2)	10 (3)	
2001 – 3000 (610 – 914)*		2-in. (51)	2-in. (51)	24 (7.3)	17 (5.1)	12 (3.6)	7 (2.1)	
3001 – 4000 (914 – 1219)		2-in. (51)	2-in. (51)	21 (6.4)	13 (3.9)	8 (2.4)		
4001 – 5000 (1219 – 1524)		2-in. (51)	2-in. (51)	17 (5.1)	10 (3)	5 (1.5)		
5001 – 6000 (1524 – 1829)		2-in. (51)	2-in. (51)	14 (4.2)	6 (1.8)			
6001 – 7000 (1829 – 2134)		2-in. (51)	2-in. (51)	10 (3)				
7001 – 8000 (2134 – 2438)		2-in. (51)	2-in. (51)	6 (1.8)				
8001 – 9000 (2438 – 2743)		2-in. (51)	2-in. (51)					
9001 – 10000 (2743 – 3048)		2-in. (51)	2-in. (51)					

*Canada

‡ Discard outlet restrictor if vent lengths or elbows exceed the above table. Discard restrictor if using 1 1/2-in. (38mm) diameter pipe. Refer to installation instructions for outlet restrictor installation guidelines.

MAXIMUM ALLOWABLE EXPOSED VENT PIPE LENGTH (FT./M) WITH AND WITHOUT INSULATION IN WINTER DESIGN TEMPERATURE AMBIENT*

FURNACE SIZE	WINTER DESIGN TEMPERATURE °F (°C)	MAX PIPE DIAMETER IN (mm)	WITHOUT INSULATION FT. (M)	WITH 3/8-IN. (10 mm) OR THICKER INSULATION† FT. (M)
040	20 (-7)	1.5 (38)	51 (16)	70 (21)
	0 (-18)	1.5 (38)	28 (9)	70 (21)
	-20 (-29)	1.5 (38)	16 (5)	70 (21)
	20 (-7)	2 (51)	45 (14)	70 (21)
	0 (-18)	2 (51)	22 (7)	70 (21)
	-20 (-29)	2 (51)	10 (3)	58 (18)
060	20 (-7)	2 (51)	65 (20)	70 (21)
	0 (-18)	2 (51)	35 (11)	70 (21)
	-20 (-29)	2 (51)	20 (6)	70 (21)
080	20 (-7)	2 (51)	55 (17)	55 (17)
	0 (-18)	2 (51)	48 (15)	55 (17)
	-20 (-29)	2 (51)	30 (9)	55 (17)
	20 (-7)	2.5 (64)	70 (21)	70 (21)
	0 (-18)	2.5 (64)	47 (14)	70 (21)
	-20 (-29)	2.5 (64)	28 (9)	70 (21)
100	20 (-7)	2.5 (64)	40 (12)	40 (12)
	0 (-18)	2.5 (64)	40 (12)	40 (12)
	-20 (-29)	2.5 (64)	38 (12)	40 (12)
	20 (-7)	3 (76)	70 (21)	70 (21)
	0 (-18)	3 (76)	50 (15)	70 (21)
	-20 (-29)	3 (76)	28 (9)	70 (21)
120	20 (-7)	3 (76)	70 (21)	70 (21)
	0 (-18)	3 (76)	61 (19)	70 (21)
	-20 (-29)	3 (76)	37 (11)	70 (21)
	20 (-7)	4 (102)	70 (21)	70 (21)
	0 (-18)	4 (102)	48 (15)	70 (21)
	-20 (-29)	4 (102)	23 (7)	70 (21)
140	20 (-7)	3 (76)	60 (18)	60 (18)
	0 (-18)	3 (76)	60 (18)	60 (18)
	-20 (-29)	3 (76)	44 (13)	60 (18)
	20 (-7)	4 (102)	70 (21)	70 (21)
	0 (-18)	4 (102)	57 (17)	70 (21)
	-20 (-29)	4 (102)	30 (9)	70 (21)

* Pipe length (ft) specified for maximum pipe lengths located in unconditioned spaces. Pipes located in unconditioned space cannot exceed total allowable pipe length as specified in Table NO TAG.

† Insulation thickness based on R value of 3.5 per in.

58MXB

TYPICAL INSTALLATIONS

58MXB

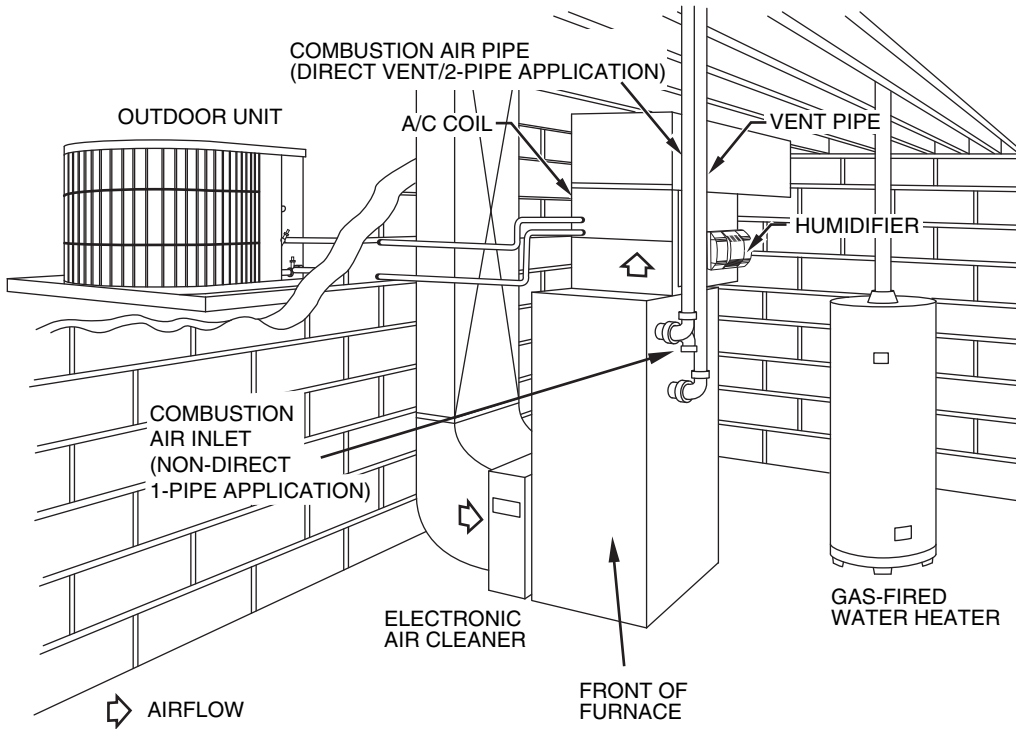

Basement - Upflow Application

A05064

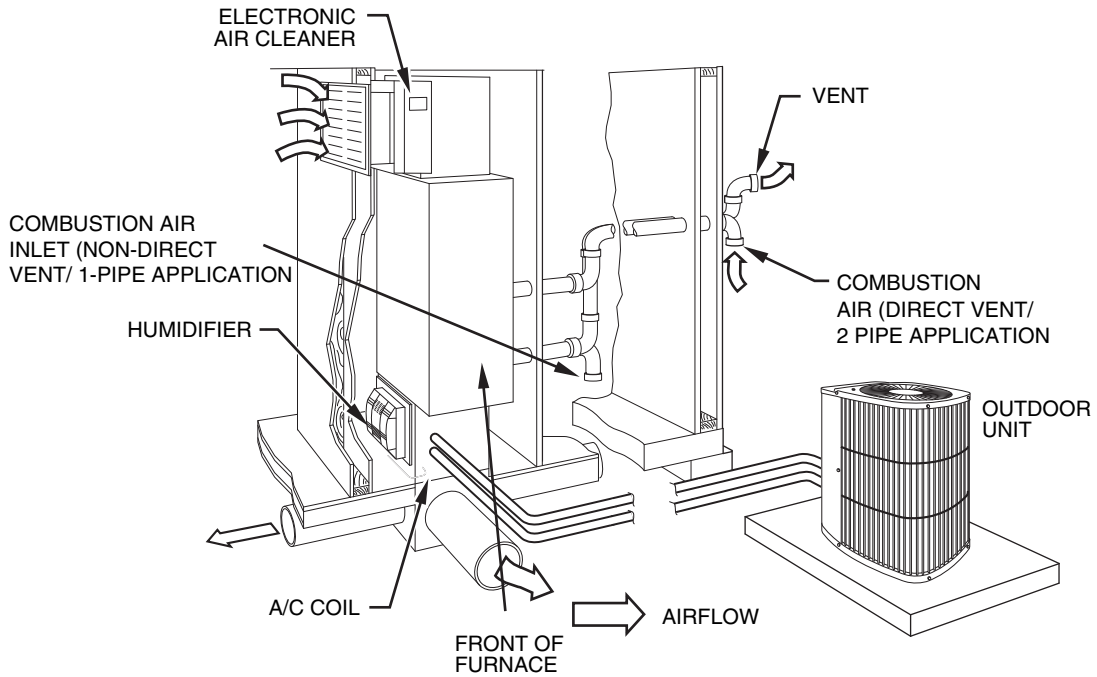

Closet - Downflow Application

A05065

TYPICAL INSTALLATIONS (CONTINUED)

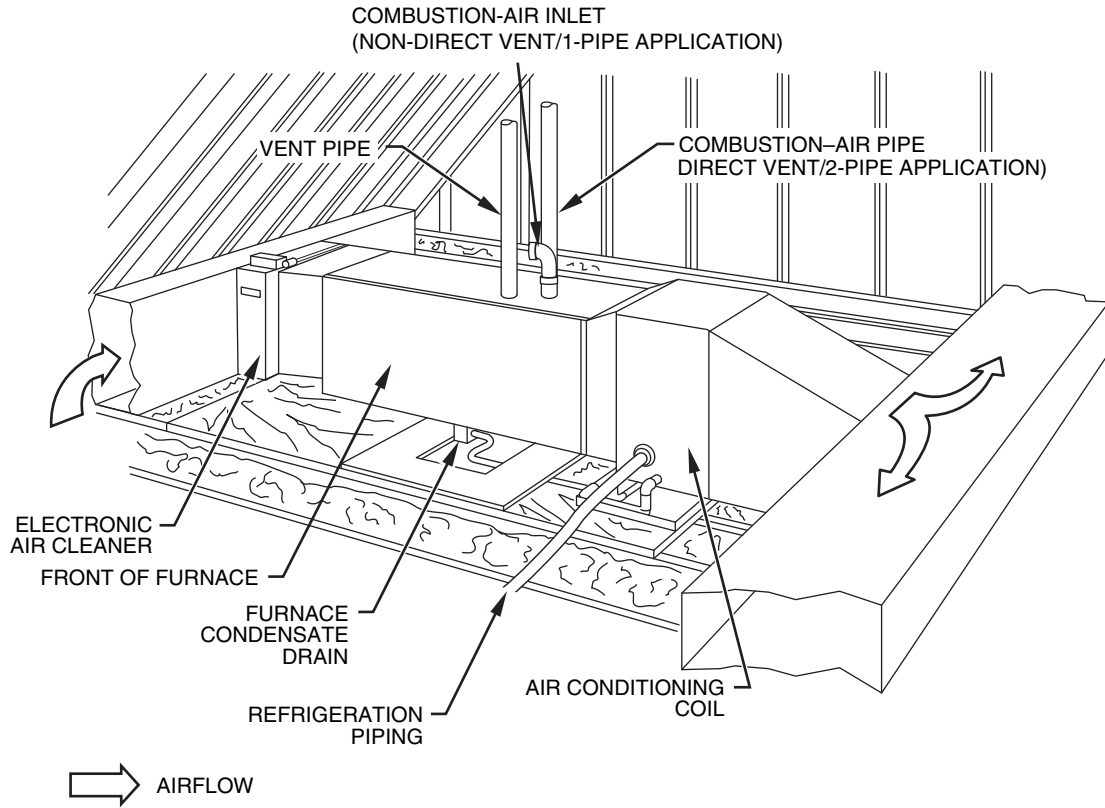

58MXB

A05066

Attic - Horizontal Application

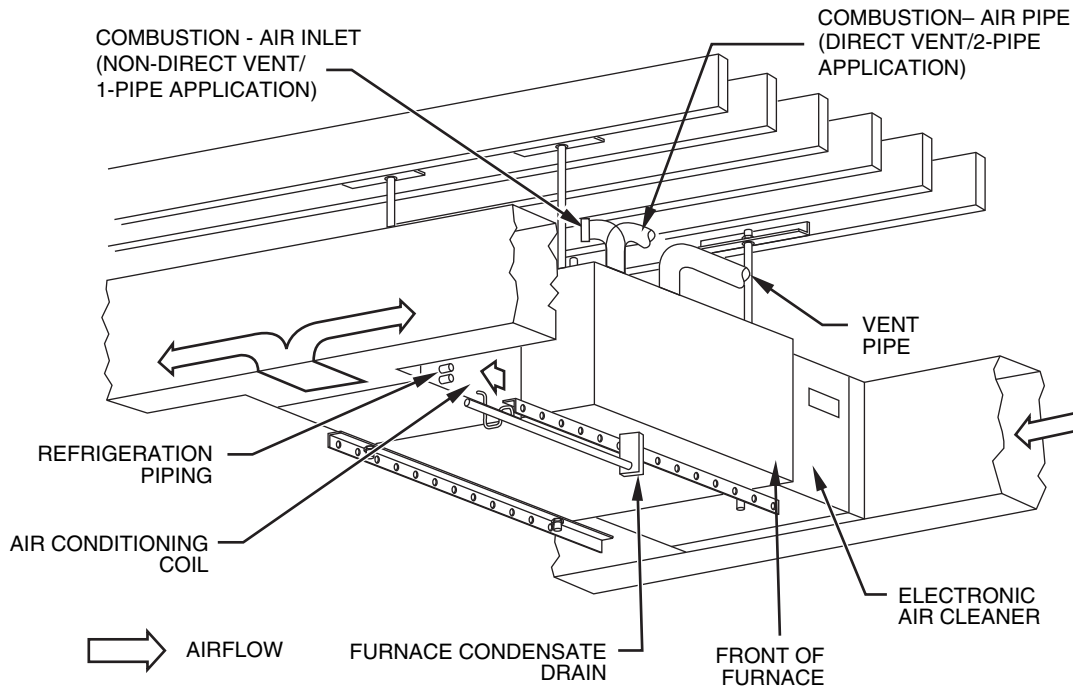

A05067

Crawlspace - Horizontal Application

GUIDE SPECIFICATIONS

Legacy Comfort 92
Single-Stage / Deluxe Gas Furnace
58MXB

GENERAL

System Description

Furnish a _____ (4-way multipoise) fixed capacity gas-fired condensing furnace for use with natural gas or propane (factory authorized conversion kit required for propane); furnish cold air return plenum; furnish side (external) filter rack.

Quality Assurance

Unit will be designed, tested and constructed to the current ANSI Z21.47/CSA 2.3 design standard for gas-fired central furnaces. Unit will be 3rd party certified by CSA to the current ANSI Z21.47/CSA 2.3 design standard for gas-fired central furnaces. Unit will carry the CSA Blue Star® and Blue Flame® labels.

Unit efficiency testing will be performed per the current DOE test procedure as listed in the Federal Register.

Unit will be certified for capacity and efficiency and listed in the latest GAMA Consumer's Directory of Certified Efficiency Ratings.

Unit will carry the current Federal Trade Commission Energy Guide efficiency label.

Delivery, Storage, and Handling

Unit will be shipped as single package only and is stored and handled per unit manufacturer's recommendations.

Warranty (for inclusion by specifying engineer) U.S. and Canada only. Warranty certificate available upon request.

PRODUCTS

Equipment

Components shall include: slow-opening gas valve to reduce ignition noise, regulate gas flow, with electric switch gas shut-off; flame proving sensor, hot surface igniter, pressure switch assembly verifies inducer operation; flame rollout switch, drain tubing and installed condensate drain trap, blower and inducer assembly, 40va transformer; low-voltage (heating) (heating/ cooling) thermostat.

Blower Wheel and Blower Motor

Galvanized blower wheel shall be centrifugal type, statically and dynamically balanced. Blower motor of PSC type shall be permanently lubricated with sealed bearings, of _____ hp, and shall be multiple-speed direct drive. Blower motor shall be soft mounted to the blower scroll to reduce vibration transmission.

Filters

Furnace shall have reusable-type filters. Filter shall be _____ in. (mm) x _____ in. (mm). A high efficiency media filter is available as an option. _____ Media Filter.

Casing

Casing shall be of .030 in. (.7 mm) thickness minimum, pre-painted galvanized steel.

Inducer Motor

Inducer motor shall be soft mounted to reduce vibration transmission.

Primary Heat Exchangers

Primary Heat exchangers shall be 3-Pass 20 gauge corrosion resistant aluminized steel of fold-and-crimp sectional design, which operates under negative pressure.

Secondary Heat Exchangers

Secondary Heat exchangers shall be of a flow-through design having a patented interior laminate coating of polypropylene for greater corrosion resistance with fold-and-crimp design, which operates under negative pressure.

Controls

Controls shall include a microprocessor based integrated electronic control board with at least 11 service troubleshooting codes displayed via diagnostic flashing LED light on the control, has ability to store fault codes, when activated a self-test feature checks all major functions of the furnace within one minute, and a replaceable automotive-type circuit protection fuse. Multiple operational settings available including separate blower speeds. Cooling airflow will be selectable between 350 or 400 CFM per ton of air conditioning. Features will also include temporary reduced airflow in the cooling mode for improved dehumidification when a Thermidistat™ is selected as the thermostat.

Operating Characteristics

Heating Capacity shall be _____ Btuh input; _____ Btuh output capacity.

Fuel Gas Efficiency shall be 93% AFUE. Air delivery shall be _____ cfm minimum at 0.50 in. wg. external static pressure. Dimensions shall be: depth _____ in. (mm); width _____ in. (mm); height _____ in. (mm)(casing only). Height shall be _____ in.(mm) with A/C coil and _____ in. (mm) overall with plenum.

Electrical Requirements

Electrical supply shall be 115 volts, 60 Hz, single-phase (nominal). Minimum wire size shall be _____ AWG; maximum fuse size or HACR-type, designated circuit breaker shall be _____ Amps.

Special Features

Refer to section of the product data sheet identifying accessories and descriptions for specific features and available enhancements.