

**40QAC/QAQ
Cooling Only and Heat Pump
Ceiling Suspended Fan Coil
2 to 5 Nominal Tons**

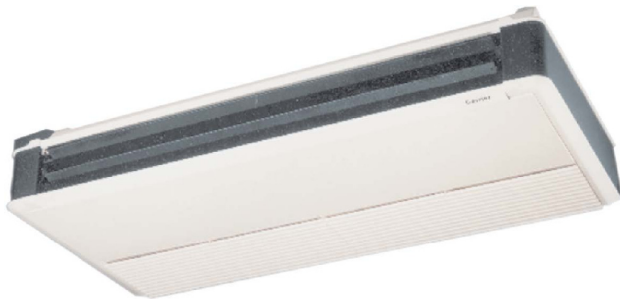

Turn to the Experts.™

Product Data



The 40QA Energy-Efficient Ceiling Suspended fan coil incorporates innovative technology to provide reliable cooling and heating performance. Built into these units are features most desired by the industry, including:

- SEER (Seasonal Energy Efficiency Ratio) ratings of up to 13.0 when matched with Duct Free System Condensing Units. All models are UL (Underwriters' Laboratories); UL, Canada; ARI and CEC (California Energy Commission) listed.
- A wide range of accessories is available to meet a variety of installation requirements.
- The 40QA series is ideal for applications where there is no available space above the ceiling and no room to hang a unit on a wall.

FEATURES / BENEFITS

Technology and Components

- A high-efficiency, four-row heat exchanger has mechanically expanded copper tubes with continuous aluminum fins. The coil connections are made of brass.

Fan Motor

- The direct-drive fan has a three-speed permanent split capacitor motor with built-in thermal protection, regulated by an electronic thermostat. The motor is installed on anti-vibration mounts to ensure quiet operation. The fan blade design ensures uniform airflow through the heat exchanger.

Air Distribution

- Air distribution provides individual comfort with the features of horizontal air sweep and vertical deflectors. The special design of air distribution ensures rapid blending of the supply and room air. Conditioned air can be directed in numerous positions, then evenly distributed throughout the room. Return air enters the unit through the bottom back of the unit. It is then cleaned by an easily removable, washable filter.

Controls

- A choice of three different thermostats are available, suitable for installation on a wall. The solid-state electronic thermostat is available in Slim Line, Flat Stat, and a 5-1-1 programmable NP-thermostat. Thermostat features include:
 - Three-speed manual setting
 - Automatic changeover

Fast Installation

- Carrier's compact systems take only a few hours to install — only wire and piping need to be run. The fast and easy installation ensures minimal disruption to customers in the home or workplace.

Built-In Reliability

- Carrier split system units are designed to provide years of trouble-free operation with features such as freeze protection and 24-volt controls.

Flexibility

- A variety of accessories make this unit versatile for use in any applications. Available accessories include: Low ambient controls, Slim Line thermostat, Flat Stat thermostat, Non-Programmable thermostat, condensate pump, fresh air intake kit, power vent fan for fresh air intake, and remote room sensor.

Limited Warranty

- One year limited parts

MODEL NUMBER NOMENCLATURE

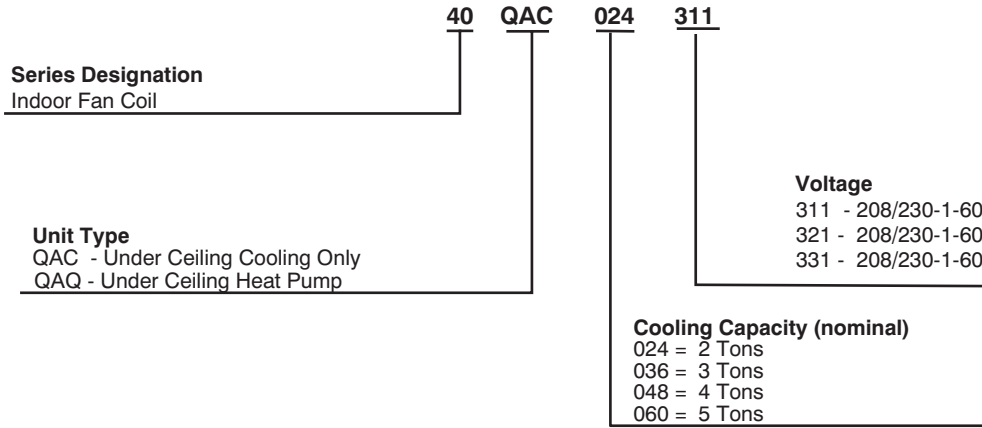

A07245

40QAC/QAQ

PHYSICAL DATA

UNIT	40QAC024	40QAC036	40QAC048	40QAC060	40QAQ024	40QAQ036	40QAQ048	40QAQ060
NOMINAL CAPACITY (Tons)	2.0	3.0	4.0	5.0	2.0	3.0	4.0	5.0
OPERATING WEIGHT (lb)	108	117	149	179	110	119	151	181
MOISTURE REMOVAL (pts/hr)	7.1	9.5	13.4	15.1	7.1	9.5	13.4	15.1
REFRIGERANT TYPE	R410A							
METERING DEVICE (Note 1)	TXV				Accurater			
INDOOR FAN (Direct Drive)	TXV							
High CFM/Watts	600/100	840/282	1200/405	1600/569	600/100	840/282	1200/425	1600/504
Med CFM/Watts	300/90	740/248	1160/384	1220/496	500/90	240/248	1160/384	1220/496
Low CFM/Watts	400/80	840/213	1100/343	1640/428	400/80	640/213	1100/343	1040/428
Air Throw ft (high fan)	30	40	45	45	27	38	40	40
Quantity	1	1	2	2	1	1	2	2
Hp	1/15	1/6		1/15		1/6		
BLOWER WHEEL								
Quantity	2	2	3	4	2	2	3	4
Size (in.)	6 x 8	6 x 8	6 x 8	6 x 8	6 x 8	6 x 8	6 x 8	6 x 8
INDOOR COIL DATA								
Face Area (sq ft)	2.2	2.6	3.3	4.5	2.2	2.6	3.3	4.5
No. of Rows	4	4	4	4	4	4	4	4
FPI	15	15	15	15	15	15	15	15
Circuits	4	4	8	8	4	4	8	8
Filters (Cleanable)								
Quantity	4	5	Note 2	6	4	5	Note 2	6
Size (in.)	12 x 8.75	10.6 x 8.7	Note 2	12 x 8.75	12 x 8.75	10.6 x 8.7	Note 2	12 x 8.75
REFRIGERANT LINES								
Connection Type	Flare	Flare	Flare	Flare	Flare	Flare	Flare	Flare
Liquid Line (in.)	3/8 OD	3/8 OD	3/8 OD	3/8 OD	3/8 OD	3/8 OD	3/8 OD	3/8 OD
Vapor Line (in.)	5/8 OD	3/4 OD	3/4 OD	3/4 OD	5/8 OD	3/4 OD	7/8 OD*	7/8 OD*
Max Length, Lift & Drop	Note 3	Note 3	Note 3	Note 3	Note 3	Note 3	Note 3	Note 3
CONDENSATE DRAIN								
Outside Dia (in.) (Male pipe thd) (Note 4)	3/4							
CONTROLS (Solid State)								
Wall Thermostat (Required)	Yes	Yes	Yes	Yes	Yes	Yes	Yes	Yes
Freeze Protection	Yes	Yes	Yes	Yes	Yes	Yes	Yes	Yes
Defrost Method	N/A	N/A	N/A	N/A	Time/Temp	Time/Temp	Time/Temp	Time/Temp
Fan Speeds	H/M/L/Auto	H/M/L/Auto	H/M/L/Auto	H/M/L/Auto	H/M/L/Auto	H/M/L/Auto	H/M/L/Auto	H/M/L/Auto
Control Voltage	24V							
System Voltage	208/230 v							
AIR SWEEP								
Horizontal	Automatic	Automatic	Automatic	Automatic	Automatic	Automatic	Automatic	Automatic
Vertical	Manual	Manual	Manual	Manual	Manual	Manual	Manual	Manual
Finish	Note 5	Note 5	Note 5	Note 5	Note 5	Note 5	Note 5	Note 5

* Valve connection size is 3/4-in. Recommended line size is 7/8-in.

NOTES:

1. Metering device located in the indoor unit.
2. 4 pieces 10.6" x 8.7" and 2 pieces 12.0" x 8.7"
3. See matching condenser for line lengths.
4. Flexible tubing (5/8 in.) required when optional condensate pump is used.
5. GM Motor Home White with black trim.

ARI* CAPACITY RATINGS

COOLING ONLY UNDER CEILING

INDOOR UNIT	OUTDOOR UNIT	ARI CAPACITY (Btuh)	EXPANSION DEVICE INDOOR	SEER
40QAC024-3	38HDR018-3	18,000	TXV	13.0
40QAC024-3	38HDR024-3	23,000		
40QAC036-3	38HDR030-3	29,000		
40QAC036-3	38HDR036-3, 5, 6	33,000		
40QAC048-3	38HDR048-3, 5, 6	46,000		
40QAC060-3	38HDR060-3, 5, 6	56,000		

HEAT PUMP UNDER CEILING (WITH ELECTRIC HEAT)

INDOOR UNIT	OUTDOOR UNIT	ARI CAPACITY COOLING (Btuh)	ARI CAPACITY HEATING (Btuh)	Heater kW	EXPANSION DEVICE INDOOR	ACCURATER PISTON OUTDOOR	SEER	HSPF
40QAQ024-3	38QRR018-3	17,000	17,000	2kW	Accurater Piston	40	13.0	7.7
	38QRR024-3	23,000	23,800			49		
40QAQ036-3	38QRR030-3	28,000	28,800	3kW		55		
	38QRR036-5,6	33,000	32,000			63		
40QAQ048-3	38QRR048-3,5,6	45,000	45,000	4kW		73		
40QAQ060-3	38QRR060-3,5,6	56,000	54,000	5kW		80		

* ARI – Air Conditioning and Refrigeration Institute.

NOTES:

- For expanded ratings, see matching condenser Product Data.
- Air entering evaporator 80°F dry bulb. Air entering evaporator 72°F wet bulb.
- Rated and certified in accordance with ARI Standards 210/240 and 270.

SOUND DATA

SOUND DATA - UNDER CEILING FAN COILS (A-WEIGHTED)

UNIT	SOUND PRESSURE(dBa)	SOUND POWER (dBa)	FAN SPEED	SOUND POWER DATA OCTAVE BAND (dBa)						
				125	250	500	1000	2000	4000	8000
40QAC024	50.1	58.4	High	39.2	50.9	53.4	56.0	50.4	43.1	32.8
	48.9	57.2	Medium	38.1	50.0	52.6	54.7	49.0	41.5	31.8
	46.4	54.7	Low	36.4	47.7	50.7	52.3	46.3	37.4	29.5
40QAC036	60.1	68.4	High	50.2	61.0	60.5	65.0	61.7	58.9	51.5
	57.7	66.0	Medium	47.9	58.6	58.3	62.8	59.1	56.6	48.1
	54.6	62.9	Low	46.2	55.6	5.2	59.9	56.3	53.6	43.0
40QAC048	59.0	67.3	High	48.7	60.8	60.4	64.0	60.3	57.3	47.7
	58.0	66.3	Medium	47.8	59.2	59.4	63.1	59.2	56.2	46.6
	—	—	Low	—	—	—	—	—	—	—
40QAC060	61.8	70.1	High	52.5	63.6	63.7	67.0	63.3	59.0	50.0
	60.5	68.8	Medium	51.2	61.5	61.9	66.4	60.8	56.6	47.0
	57.5	65.8	Low	49.5	59.1	60.0	63.1	58.3	53.6	43.8
40QAQ024	51.1	59.4	High	42.8	51.8	54.0	56.7	52.2	45.9	36.6
	50.2	58.5	Medium	41.3	50.8	53.3	55.6	51.3	45.3	35.2
	49.5	57.8	Low	40.9	50.3	52.6	54.7	50.7	45.1	35.8
40QAQ036	60.1	68.4	High	50.2	61.0	60.5	65.0	61.7	58.9	51.5
	57.8	66.1	Medium	47.9	58.6	58.3	62.8	59.1	56.6	48.1
	54.9	63.2	Low	46.2	55.6	56.2	59.9	56.3	53.6	43.0
40QAQ048	59.0	67.3	High	48.7	60.8	60.4	64.0	60.3	57.3	47.7
	58.0	66.3	Medium	47.8	59.2	59.4	63.1	59.2	56.2	46.6
	—	—	Low	—	—	—	—	—	—	—
40QAQ060	61.8	70.1	High	52.5	63.6	63.7	67.0	63.3	59.0	50.0
	60.5	68.8	Medium	51.2	61.5	61.9	66.4	60.8	56.6	47.0
	57.5	65.8	Low	49.5	59.1	60.0	63.1	58.3	53.6	43.8

LEGEND:

ARI – Air Conditioning and Refrigeration Institute

dBa – Decibels on the A scale

NOTES:

- Sound levels are taken in accordance with ARI Sound Standard 350.
- Sound pressure data is measured at 1m from the unit.

40QAC/QAQ

ACCESSORIES

Ordering Number	Description	Models Used On
53DFS250-SL	Thermostat - Slim Line 7-Day Programmable	All 40QAC & QAQ
53DFS250-FS	Thermostat - Flat Stat 7-Day Programmable	All 40QAC
53DFST2-NP	Thermostat - Super T2 5-1-1 Commercial	All 40QAC
53DS-900---081	Condensate Pump	All 40QA
53DS-900---006	Fresh Air Intake Mounting Kit	All 40QA (2 required for 048 & 060 size models)
53DS-900---066	Power Vent Fan Motor (used with 53DS-900-006)	All 40QA
33CSSEN-WB	Remote Room Sensor Kit	All 53DFS SL/FS Only Thermostats

FIELD INSTALLED ACCESSORIES

Slim Line Thermostat

A specially designed thermostat for Duct-Free Systems that incorporate 3-speed control, programmability, auto changeover, backlight, locking keypad and a large LCD display. (Slim Line thermostats can only be used on cooling only, heat pumps and heat/cool systems.)

Flat Stat thermostat

A specially designed thermostat for Duct-Free Systems that incorporates 3-speed control, programmability, auto changeover, backlight, locking keypad and a large LCD display that is mounted flush to the wall. (Flat Stat thermostats can only be used on cooling only and heat/cool systems.)

NP - Thermostat

A specially designed thermostat for Duct-Free Systems that incorporates 3-speed control, 5-1-1 (Monday through Friday - Saturday - Sunday) programmability, auto changeover, backlight, locking keypad and a large LCD display. (NP - thermostats can only be used on cooling only and heat/cool systems.)

Fresh air intake kit

Provides for a variable amount of outdoor air to be mixed with the conditioned air.

Power Vent Fan for Fresh Air Intake

provides up to 30% of outdoor air to be supplied to the conditioned space (requires intake kit).

Remote Room Sensor Kit

Designed to sense the air temperature at a remote location and send this information by digital communication to the thermostat (used on Slim Line and Flat Stat thermostats only).

40QAC/QAQ

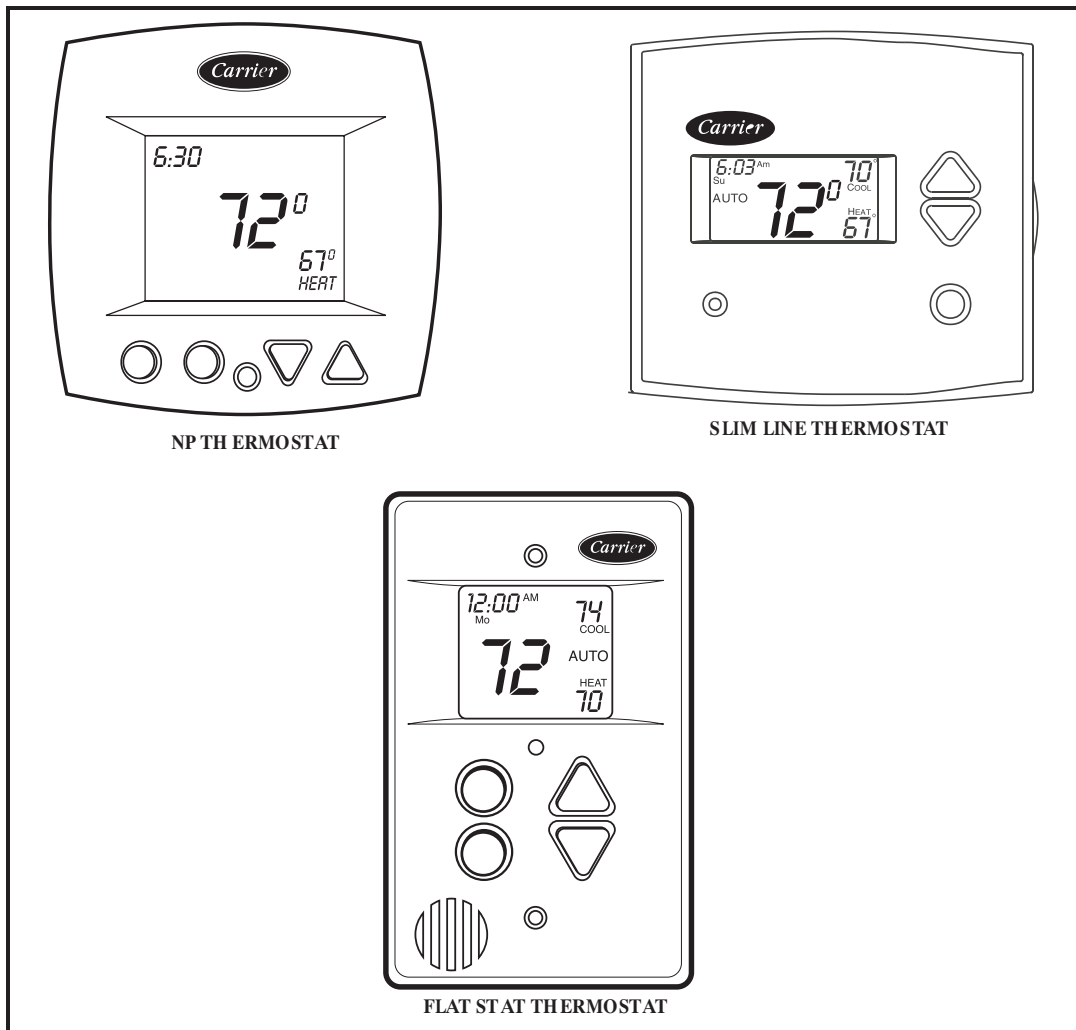

DIMENSIONS

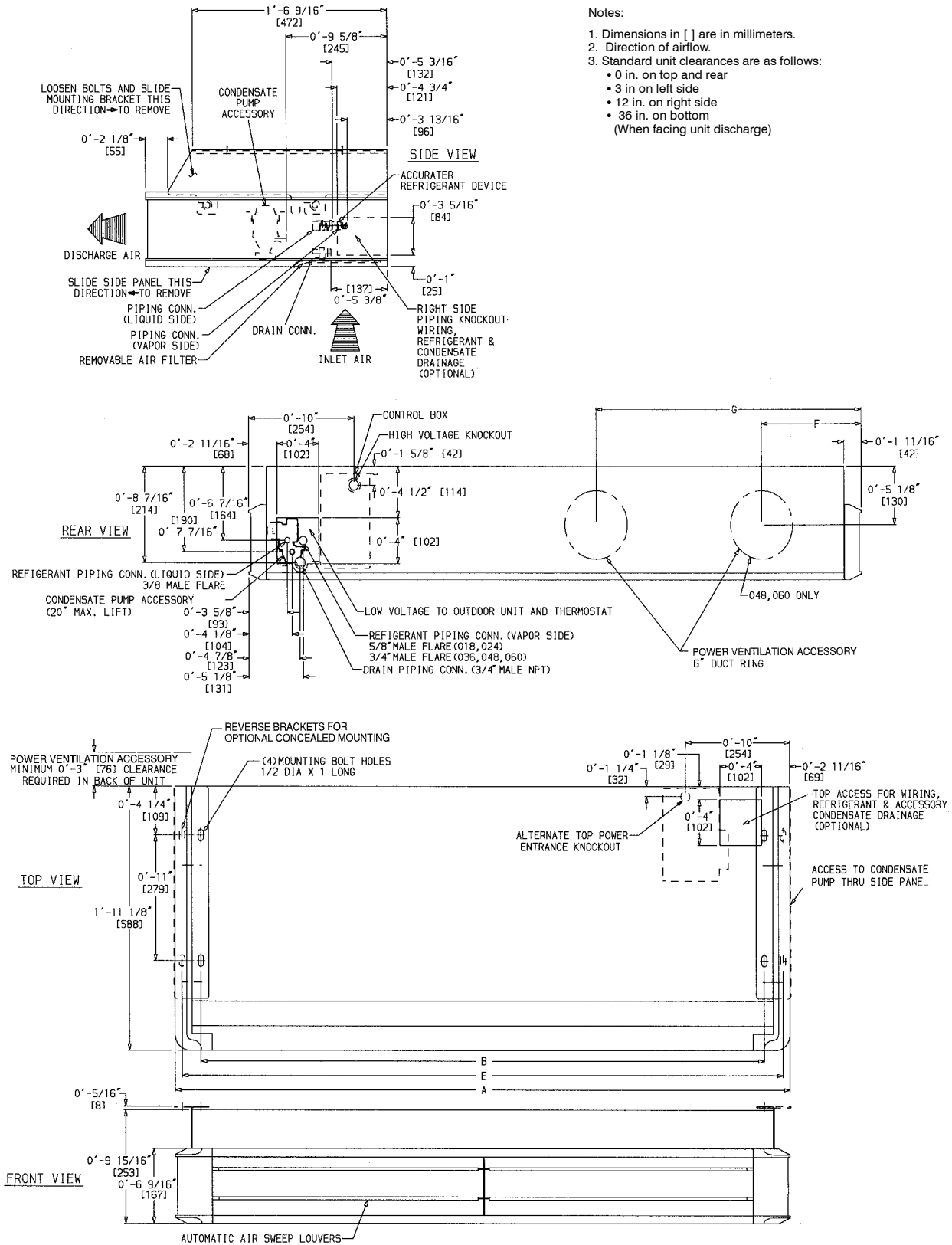

40QAC/QAQ

UNIT SIZE	WEIGHT (lb)		A		B		E		F		G	
	Cooling Only	Heat Pump	ft-in.	mm	ft-in.	mm	ft-in.	mm	ft-in.	mm	ft-in.	mm
024	108	110	4-215/16	1294	3-10	1169	4-15/8	1260	—	—	1-95/8	549
036	117	119	4-1013/16	1493	4-57/8	1368	4-91/2	1459	—	—	2-11/2	648
048	149	151	5-119/16	1817	5-65/8	1692	5-101/4	1783	1-97/8	555	3-31/16	992
060	179	181	7-8	2336	7-3	2211	7-65/8	2302	1-115/8	601	4-119/16	1512

PERFORMANCE DATA

COOLING CAPACITIES 40QAC024 WITH 38HDR018

Temp (°F) Air Entering Condenser (Edb)	Air Entering Evaporator – Cfm/BF												
	320/0.02				400/0.03				500/0.03				
	Air Entering Evaporator – Ewb °F (°C)												
	57 (13.4)	62 (16.7)	67 (19.4)	72 (22.3)	57 (13.4)	62 (16.7)	67 (19.4)	72 (22.3)	57 (13.4)	62 (16.7)	67 (19.4)	72 (22.3)	
55	TCG	17.2	18.7	20.1	21.5	17.7	19.1	20.5	21.8	18.1	19.5	20.8	22.1
	SHG	16.8	15.0	12.9	10.7	17.2	15.7	13.3	10.9	18.1	16.4	13.8	11.2
	TC	17.0	18.5	19.9	21.3	17.4	18.8	20.2	21.6	17.8	19.3	20.6	21.9
	kW	0.94	0.94	0.94	0.94	0.94	0.94	0.94	0.94	0.94	0.95	0.94	0.94
	CMP	0.75	0.75	0.75	0.75	0.75	0.75	0.75	0.76	0.75	0.76	0.75	0.76
	LDB	46.3	50.2	54.9	59.7	49.0	52.1	56.8	61.4	51.3	54.2	58.7	63.1
65	LWB	41.6	46.9	52.5	58.2	43.0	48.4	54.0	59.7	44.5	49.9	55.4	61.1
	TCG	16.3	18.2	19.6	21.1	17.0	18.6	20.0	21.4	17.7	18.9	20.3	21.6
	SHG	16.3	14.9	12.8	10.6	17.0	15.5	13.2	10.8	17.7	16.4	13.7	11.1
	TC	16.1	17.9	19.4	20.8	16.8	18.3	19.7	21.1	17.4	18.7	20.1	21.4
	kW	1.06	1.05	1.06	1.06	1.06	1.06	1.06	1.06	1.06	1.06	1.06	1.06
	CMP	0.87	0.87	0.87	0.87	0.87	0.87	0.87	0.87	0.87	0.87	0.87	0.88
75	LDB	47.2	50.5	55.1	59.8	49.4	52.3	56.8	61.5	51.9	54.2	58.7	63.2
	LWB	42.5	47.4	52.9	58.6	43.6	48.8	54.3	60.0	44.8	50.3	55.8	61.4
	TCG	15.6	17.4	19.0	20.5	16.4	17.8	19.4	20.8	17.1	18.2	19.7	21.1
	SHG	14.9	14.6	12.6	10.4	16.4	15.3	13.1	10.7	17.1	16.2	13.7	11.0
	TC	15.4	17.2	18.8	20.3	16.2	17.5	19.1	20.6	16.9	17.9	19.5	20.9
	kW	1.17	1.19	1.19	1.19	1.18	1.18	1.19	1.19	1.18	1.19	1.19	1.19
85	CMP	0.99	1.00	1.00	1.00	0.99	1.00	1.00	1.01	1.00	1.00	1.00	1.01
	LDB	50.3	51.1	55.4	60.1	50.4	52.7	57.0	61.7	52.8	54.4	58.7	63.3
	LWB	43.3	48.1	53.4	59.0	44.1	49.4	54.8	60.3	45.3	50.8	56.1	61.7
	TCG	14.8	16.5	18.2	19.8	15.6	16.9	18.6	20.1	16.4	17.2	18.9	20.5
	SHG	14.8	13.9	12.2	10.2	15.6	14.8	12.9	10.5	16.4	15.8	13.6	10.9
	TC	14.5	16.2	18.0	19.6	15.4	16.6	18.3	19.9	16.1	17.0	18.6	20.2
95	kW	1.30	1.32	1.33	1.33	1.31	1.32	1.33	1.33	1.32	1.33	1.33	1.34
	CMP	1.12	1.13	1.15	1.15	1.13	1.14	1.15	1.15	1.14	1.14	1.15	1.15
	LDB	50.4	52.4	56.1	60.5	52.0	53.6	57.4	62.0	53.9	55.0	59.0	63.5
	LWB	44.1	49.0	54.1	59.5	44.9	50.2	55.3	60.7	45.8	51.4	56.6	62.0
	TCG	14.2	15.4	17.2	19.0	14.7	15.7	17.6	19.3	15.5	16.1	18.3	19.6
	SHG	14.2	13.3	11.8	9.8	14.7	14.2	12.5	10.2	15.5	15.2	13.5	10.7
105	TC	13.9	15.2	17.0	18.7	14.5	15.5	17.3	19.0	15.2	15.9	18.0	19.3
	kW	1.53	1.54	1.56	1.57	1.53	1.54	1.57	1.57	1.54	1.55	1.57	1.57
	CMP	1.34	1.35	1.37	1.38	1.35	1.36	1.38	1.39	1.36	1.36	1.38	1.39
	LDB	51.6	53.6	57.0	61.3	53.6	54.7	58.1	62.5	55.4	56.0	59.5	63.8
	LWB	44.7	49.9	54.9	60.1	45.6	51.1	56.0	61.3	46.5	52.2	57.2	62.5
	TCG	13.3	14.2	16.0	17.9	13.9	14.5	16.3	18.2	14.5	15.1	16.6	18.5
115	SHG	13.3	12.7	11.2	9.4	13.9	13.5	11.8	9.8	14.5	13.4	12.6	10.3
	TC	13.1	13.9	15.7	17.6	13.6	14.2	16.0	17.9	14.3	14.9	16.4	18.2
	kW	1.60	1.61	1.63	1.66	1.61	1.61	1.64	1.66	1.62	1.62	1.64	1.66
	CMP	1.42	1.43	1.45	1.47	1.42	1.43	1.45	1.47	1.43	1.43	1.46	1.48
	LDB	53.4	54.8	58.2	62.0	55.1	56.0	59.3	63.2	57.0	58.9	60.4	64.4
	LWB	45.5	51.0	55.9	60.9	46.4	52.0	56.9	62.0	47.2	52.9	58.0	63.1
125	TCG	12.3	12.9	14.6	16.5	12.8	13.3	14.9	16.8	13.4	13.8	15.2	17.1
	SHG	12.3	11.6	10.4	8.9	12.8	12.1	11.1	9.3	13.4	12.5	11.9	9.8
	TC	12.1	12.7	14.4	16.3	12.6	13.1	14.7	16.6	13.2	13.5	14.9	16.9
	kW	1.77	1.77	1.79	1.83	1.78	1.77	1.80	1.83	1.78	1.79	1.80	1.84
	CMP	1.58	1.58	1.61	1.64	1.59	1.59	1.61	1.65	1.60	1.60	1.62	1.66
	LDB	55.4	57.0	59.7	63.1	57.0	58.5	60.6	64.0	58.7	60.4	61.5	65.1
125	LWB	46.5	52.1	56.9	61.8	47.3	52.9	57.9	62.8	48.1	53.8	58.9	63.8
	TCG	11.2	11.6	13.1	14.9	11.7	11.8	13.3	15.2	12.3	12.3	13.6	15.5
	SHG	11.2	10.8	9.8	8.2	11.7	11.8	10.5	8.7	12.3	12.3	11.2	9.2
	TC	11.0	11.3	12.9	14.7	11.5	11.5	13.1	14.9	12.0	12.0	13.3	15.2
	kW	1.96	1.94	1.97	2.01	1.95	1.95	1.97	2.01	1.96	1.96	1.98	2.01
	CMP	1.77	1.76	1.78	1.82	1.77	1.76	1.79	1.83	1.78	1.77	1.79	1.83
125	LDB	57.7	58.6	60.9	64.4	59.0	59.1	61.7	65.2	60.6	60.7	62.6	66.1
	LWB	47.6	53.2	58.1	62.9	48.2	53.9	58.9	63.8	48.9	54.7	59.8	64.7

Rating Condition.

Not recommended for long-term operation

- BF – Bypass Factor
- CMP – Compressor
- Edb – Entering Dry Bulb
- Ewb – Entering Wet Bulb
- kW – Total Power
- LDB – Leaving Dry Bulb
- LWB – Leaving Wet Bulb
- SHG – Gross Sensible Capacity (1000 Btu/h)
- TC – Total Net Cooling Capacity (1000 Btu/h)
- TCG – Gross Cooling Capacity (1000 Btu/h)

NOTES:

1. Direct interpolation is permissible. Do not extrapolate.
2. The SHG is based on 80°F edb temperature of air entering indoor coil.

Below 80°F edb, subtract (corr factor x cfm) from SHG.

Above 80°F edb, add (corr factor x cfm) to SHG.

Correction Factor = 1.10 x (1 - BF) x (edb - 80).

PERFORMANCE DATA (CONT.)

COOLING CAPACITIES 40QAC024 WITH 38HDR024

Temp (°F) Air Entering Condenser (Edb)	Air Entering Evaporator – Cfm/BF												
	400/0.03				500/0.03				600/0.04				
	Air Entering Evaporator – Ewb °F (°C)												
	57 (13.4)	62 (16.7)	67 (19.4)	72 (22.3)	57 (13.4)	62 (16.7)	67 (19.4)	72 (22.3)	57 (13.4)	62 (16.7)	67 (19.4)	72 (22.3)	
55	TCG	22.1	24.2	25.3	26.2	22.3	24.3	25.4	26.2	22.8	24.7	25.5	26.3
	SHG	21.1	19.1	16.0	12.9	21.5	19.3	16.1	13.0	22.8	20.0	16.3	13.1
	TC	21.8	23.8	25.0	25.8	21.9	24.0	25.0	25.9	22.5	24.4	25.2	26.0
	kW	1.19	1.19	1.20	1.20	1.19	1.20	1.20	1.20	1.19	1.20	1.20	1.20
	CMP	1.00	1.01	1.02	1.02	1.00	1.01	1.02	1.02	1.00	1.02	1.02	1.02
	LDB	44.3	48.0	53.7	59.3	45.1	49.1	54.6	60.0	46.0	50.6	56.4	61.5
65	LWB	40.1	45.4	51.5	57.8	40.8	46.0	52.1	58.4	41.9	47.2	53.5	59.7
	TCG	21.6	23.6	25.5	26.4	21.8	23.8	25.5	26.4	22.2	24.3	25.7	26.6
	SHG	20.9	19.0	16.3	13.2	21.3	19.4	16.4	13.2	22.1	20.1	16.8	13.4
	TC	21.2	23.3	25.1	26.1	21.4	23.5	25.2	26.1	21.8	24.0	25.4	26.3
	kW	1.35	1.35	1.36	1.37	1.35	1.35	1.36	1.37	1.35	1.36	1.36	1.37
	CMP	1.16	1.17	1.17	1.18	1.16	1.17	1.18	1.18	1.16	1.17	1.18	1.19
75	LDB	44.6	48.3	53.2	58.8	45.3	48.8	54.0	59.5	47.1	50.3	55.6	61.0
	LWB	40.6	45.8	51.4	57.7	41.2	46.3	52.0	58.3	42.4	47.5	53.3	59.5
	TCG	20.9	22.9	25.0	26.4	21.1	23.1	25.1	26.5	21.8	23.5	25.5	26.7
	SHG	20.2	18.7	16.1	13.2	20.4	19.0	16.4	13.4	21.5	20.0	17.0	13.6
	TC	20.6	22.5	24.6	26.1	20.8	22.7	24.8	26.2	21.5	23.2	25.2	26.4
	kW	1.51	1.53	1.54	1.55	1.52	1.53	1.54	1.55	1.53	1.53	1.54	1.55
85	CMP	1.33	1.35	1.35	1.36	1.33	1.35	1.35	1.36	1.34	1.35	1.35	1.37
	LDB	45.9	48.8	53.5	58.7	46.8	49.4	54.0	59.3	47.9	50.6	55.4	60.7
	LWB	41.2	46.4	51.7	57.7	41.7	46.9	52.3	58.2	42.7	48.1	53.5	59.5
	TCG	20.0	21.9	24.1	26.0	20.2	22.1	24.3	26.2	21.0	22.5	24.7	26.4
	SHG	20.0	18.3	15.8	13.1	20.2	18.6	16.1	13.2	21.0	19.5	16.7	13.5
	TC	19.7	21.6	23.8	25.7	19.9	21.8	24.0	25.8	20.6	22.2	24.3	26.1
95	kW	1.69	1.72	1.73	1.74	1.70	1.73	1.74	1.75	1.71	1.73	1.74	1.75
	CMP	1.51	1.54	1.55	1.56	1.51	1.54	1.55	1.56	1.53	1.54	1.55	1.56
	LDB	46.3	49.5	54.0	59.0	47.2	50.0	54.5	59.5	48.8	51.2	55.7	60.8
	LWB	42.0	47.1	52.3	57.9	42.5	47.6	52.9	58.5	43.3	48.7	54.0	59.6
	TCG	19.2	20.8	23.1	25.2	19.5	21.0	23.2	25.3	20.1	21.4	23.3	25.6
	SHG	19.2	17.7	15.4	12.8	19.5	18.0	15.7	12.9	20.1	18.9	16.1	13.3
105	TC	18.9	20.5	22.7	24.8	19.1	20.7	22.9	25.0	19.7	21.0	23.0	25.2
	kW	1.89	1.92	1.95	1.96	1.89	1.92	1.95	1.96	1.91	1.93	2.00	2.01
	CMP	1.70	1.73	1.76	1.77	1.71	1.73	1.76	1.77	1.72	1.74	1.82	1.83
	LDB	47.6	50.5	54.7	59.4	48.4	51.0	55.2	60.0	50.1	52.1	56.3	61.2
	LWB	42.7	48.0	53.1	58.5	43.1	48.5	53.6	59.0	44.0	49.5	54.6	60.1
	TCG	18.2	19.5	21.8	24.1	18.5	19.7	22.0	24.2	19.1	20.1	22.3	24.5
115	SHG	18.2	17.0	14.8	12.4	18.5	17.4	15.1	12.6	19.1	18.2	15.8	13.0
	TC	17.9	19.2	21.5	23.7	18.2	19.4	21.6	23.9	18.8	19.7	22.0	24.2
	kW	2.10	2.12	2.17	2.19	2.10	2.12	2.17	2.19	2.11	2.13	2.18	2.20
	CMP	1.91	1.93	1.98	2.01	1.92	1.94	1.99	2.01	1.93	1.95	2.00	2.01
	LDB	49.3	51.6	55.7	60.1	50.0	52.0	56.1	60.6	51.6	53.1	57.0	61.6
	LWB	43.6	49.0	54.0	59.2	43.9	49.4	54.4	59.6	44.7	50.4	55.4	60.6
125	TCG	17.1	18.1	20.4	22.7	17.4	18.3	20.5	22.8	18.0	19.0	20.9	23.2
	SHG	17.1	16.3	14.2	11.9	17.4	16.7	14.4	12.1	18.0	17.0	15.1	12.5
	TC	16.8	17.8	20.0	22.4	17.1	17.9	20.2	22.5	17.7	18.6	20.5	22.8
	kW	2.32	2.34	2.39	2.44	2.33	2.34	2.40	2.44	2.34	2.35	2.41	2.45
	CMP	2.13	2.15	2.21	2.26	2.14	2.16	2.21	2.26	2.15	2.16	2.22	2.26
	LDB	51.1	52.8	56.7	60.9	51.8	53.2	57.2	61.4	53.2	55.0	58.1	62.3
125	LWB	44.5	50.1	55.0	60.0	44.8	50.5	55.4	60.4	45.5	51.1	56.2	61.4
	TCG	15.9	16.8	18.7	21.1	16.2	17.1	18.9	21.3	16.8	17.4	19.3	21.5
	SHG	15.9	15.0	13.4	11.3	16.2	15.2	13.7	11.5	16.8	16.0	14.4	11.9
	TC	15.6	16.5	18.3	20.8	15.9	16.8	18.6	20.9	16.5	17.1	18.9	21.2
	kW	2.56	2.56	2.62	2.71	2.56	2.57	2.63	2.71	2.58	2.59	2.64	2.71
	CMP	2.37	2.38	2.44	2.52	2.38	2.39	2.44	2.52	2.39	2.40	2.46	2.53
LDB	53.2	55.0	58.0	61.9	53.7	55.6	58.3	62.2	55.1	56.5	59.1	63.1	
LWB	45.4	51.1	56.1	60.9	45.7	51.3	56.4	61.3	46.4	52.1	57.2	62.2	

Rating Condition.

Not recommended for long-term operation

BF – Bypass Factor

CMP – Compressor

Edb – Entering Dry Bulb

Ewb – Entering Wet Bulb

kW – Total Power

LDB – Leaving Dry Bulb

LWB – Leaving Wet Bulb

SHG – Gross Sensible Capacity (1000 Btuh)

TC – Total Net Cooling Capacity (1000 Btuh)

TCG – Gross Cooling Capacity (1000 Btuh)

NOTES:

1. Direct interpolation is permissible. Do not extrapolate.
2. The SHG is based on 80°F edb temperature of air entering indoor coil.

Below 80°F edb, subtract (corr factor x cfm) from SHG.

Above 80°F edb, add (corr factor x cfm) to SHG.

Correction Factor = $1.10 \times (1 - BF) \times (edb - 80)$.

40QAC/QAC

PERFORMANCE DATA (CONT.)

COOLING CAPACITIES 40QAC036 WITH 38HDR030

Temp (F) Air Entering Condenser (Edb)	Air Entering Evaporator – Cfm/BF												
	640/0.02				740/0.02				840/0.03				
	Air Entering Evaporator – Ewb °F (°C)												
	57 (13.4)	62 (16.7)	67 (19.4)	72 (22.3)	57 (13.4)	62 (16.7)	67 (19.4)	72 (22.3)	57 (13.4)	62 (16.7)	67 (19.4)	72 (22.3)	
55	TCG	29.0	31.4	33.0	34.1	29.8	31.8	33.2	34.2	30.6	32.0	33.4	34.3
	SHG	28.0	25.8	21.4	17.1	28.5	26.5	21.9	17.3	30.6	27.4	22.2	17.5
	TC	28.2	30.6	32.2	33.3	29.1	31.1	32.5	33.5	29.8	31.3	32.6	33.6
	kW	1.57	1.57	1.58	1.58	1.56	1.57	1.58	1.58	1.57	1.58	1.59	1.58
	CMP	1.22	1.22	1.23	1.23	1.21	1.22	1.23	1.23	1.22	1.23	1.24	1.23
	LDB	47.4	50.3	55.8	61.2	49.9	52.3	57.6	62.8	50.4	53.7	59.2	64.1
65	LWB	42.0	47.3	53.3	59.5	43.1	48.7	54.6	60.8	44.1	49.9	55.8	61.8
	TCG	28.6	30.9	33.1	34.4	29.3	31.4	33.3	34.6	30.2	31.9	33.6	34.8
	SHG	27.5	26.0	21.8	17.6	29.3	27.1	22.5	17.8	30.2	28.1	23.2	18.0
	TC	27.8	30.2	32.3	33.7	28.6	30.7	32.5	33.9	29.4	31.1	32.8	34.0
	kW	1.74	1.74	1.74	1.76	1.73	1.74	1.75	1.76	1.74	1.74	1.75	1.76
	CMP	1.39	1.39	1.39	1.41	1.38	1.39	1.40	1.41	1.39	1.39	1.40	1.41
75	LDB	48.0	50.1	55.4	60.7	49.0	51.6	56.9	62.2	50.8	53.1	58.2	63.5
	LWB	42.3	47.6	53.2	59.3	43.4	48.9	54.6	60.6	44.3	49.9	55.7	61.6
	TCG	27.7	29.9	32.5	34.6	28.6	30.5	33.0	34.8	29.5	30.9	33.4	34.9
	SHG	27.7	25.6	21.9	17.7	28.6	26.9	22.7	18.1	29.5	28.1	23.5	18.5
	TC	26.9	29.2	31.8	33.8	27.9	29.7	32.2	34.1	28.8	30.2	32.6	34.2
	kW	1.92	1.93	1.93	1.95	1.93	1.93	1.93	1.95	1.93	1.94	1.93	1.96
85	CMP	1.57	1.58	1.58	1.60	1.58	1.58	1.58	1.60	1.58	1.59	1.58	1.61
	LDB	47.8	50.5	55.3	60.6	49.7	51.9	56.7	61.9	51.4	53.1	57.9	63.1
	LWB	42.8	48.1	53.5	59.3	43.8	49.3	54.7	60.5	44.6	50.3	55.8	61.6
	TCG	26.7	28.7	31.4	33.9	27.7	29.2	31.9	34.2	28.5	29.7	32.3	34.4
	SHG	26.7	24.9	21.6	17.5	27.7	26.3	22.4	18.0	28.5	27.5	23.3	18.5
	TC	26.0	28.0	30.7	33.1	26.9	28.4	31.2	33.5	27.8	28.9	31.6	33.7
95	kW	2.12	2.14	2.16	2.17	2.13	2.15	2.16	2.17	2.15	2.15	2.16	2.17
	CMP	1.77	1.79	1.81	1.82	1.78	1.80	1.81	1.82	1.80	1.80	1.81	1.82
	LDB	48.9	51.3	55.6	60.7	50.8	52.5	57.0	62.0	52.5	53.6	58.1	63.0
	LWB	43.4	48.8	54.0	59.6	44.3	50.0	55.2	60.7	45.1	50.9	56.1	61.7
	TCG	25.6	27.2	28.9	32.9	26.5	27.7	29.5	33.3	27.3	28.1	29.8	33.6
	SHG	25.6	24.0	20.1	17.3	26.5	25.4	21.1	17.8	27.3	26.5	22.8	18.3
105	TC	24.8	26.4	28.2	32.1	25.7	26.9	28.7	32.5	26.6	27.3	29.0	32.8
	kW	2.34	2.36	2.39	2.40	2.35	2.37	2.40	2.42	2.38	2.37	2.42	2.42
	CMP	1.99	2.01	2.04	2.05	2.00	2.02	2.05	2.07	2.03	2.02	2.07	2.07
	LDB	50.3	52.3	56.4	61.0	52.1	53.5	57.5	62.2	53.6	54.6	58.5	63.3
	LWB	44.0	49.6	54.6	60.0	44.9	50.7	55.8	61.1	45.7	51.6	56.7	62.0
	TCG	24.3	25.5	28.4	31.4	25.1	25.9	28.9	31.8	25.9	26.4	29.3	32.2
115	SHG	24.3	23.2	20.1	16.8	25.1	24.4	21.2	17.4	25.9	25.6	22.1	18.0
	TC	23.5	24.7	27.7	30.7	24.4	25.2	28.1	31.1	25.2	25.6	28.5	31.5
	kW	2.59	2.60	2.64	2.67	2.59	2.60	2.65	2.67	2.60	2.61	2.65	2.68
	CMP	2.24	2.25	2.29	2.32	2.24	2.25	2.30	2.32	2.25	2.26	2.30	2.33
	LDB	51.8	53.3	57.3	61.6	53.5	54.5	58.3	62.6	55.0	55.5	59.2	63.6
	LWB	44.8	50.5	55.5	60.6	45.6	51.5	56.5	61.6	46.3	52.3	57.3	62.5
125	TCG	22.8	23.5	26.4	29.7	23.7	24.4	26.9	30.1	24.4	24.9	27.2	30.4
	SHG	22.8	22.3	19.2	16.1	23.7	22.6	20.2	16.8	24.4	23.4	21.1	17.4
	TC	22.1	22.8	25.7	28.9	22.9	23.7	26.1	29.3	23.6	24.2	26.5	29.7
	kW	2.83	2.85	2.89	2.95	2.86	2.86	2.90	2.96	2.86	2.87	2.91	2.97
	CMP	2.48	2.50	2.54	2.60	2.51	2.51	2.55	2.61	2.51	2.52	2.56	2.62
	LDB	53.6	54.4	58.4	62.3	55.1	56.4	59.3	63.2	56.6	57.7	60.1	64.1
125	LWB	45.6	51.5	56.4	61.3	46.4	52.2	57.3	62.3	47.0	52.9	58.1	63.1
	TCG	21.2	21.7	24.1	27.4	22.0	22.2	24.5	27.8	22.7	22.7	24.9	28.1
	SHG	21.2	20.6	18.1	15.1	22.0	21.6	19.1	15.8	22.7	22.7	20.1	16.5
	TC	20.5	21.0	23.4	26.6	21.3	21.4	23.8	27.1	22.0	21.9	24.1	27.3
	kW	3.12	3.12	3.17	3.24	3.14	3.14	3.18	3.25	3.16	3.15	3.19	3.26
	CMP	2.77	2.77	2.82	2.89	2.79	2.79	2.83	2.90	2.81	2.80	2.84	2.91
125	LDB	55.5	56.4	59.6	63.4	56.9	57.5	60.4	64.3	58.2	58.4	61.2	65.0
	LWB	46.5	52.4	57.4	62.3	47.2	53.2	58.2	63.1	47.8	53.8	58.9	63.8

Rating Condition.

Not recommended for long-term operation

- BF – Bypass Factor
- CMP – Compressor
- Edb – Entering Dry Bulb
- Ewb – Entering Wet Bulb
- kW – Total Power
- LDB – Leaving Dry Bulb
- LWB – Leaving Wet Bulb
- SHG – Gross Sensible Capacity (1000 Btu/h)
- TC – Total Net Cooling Capacity (1000 Btu/h)
- TCG – Gross Cooling Capacity (1000 Btu/h)

NOTES:

1. Direct interpolation is permissible. Do not extrapolate.
2. The SHG is based on 80°F edb temperature of air entering indoor coil.

Below 80°F edb, subtract (corr factor x cfm) from SHG.

Above 80°F edb, add (corr factor x cfm) to SHG.

Correction Factor = $1.10 \times (1 - BF) \times (edb - 80)$.

PERFORMANCE DATA (CONT.)

COOLING CAPACITIES 40QAC036 WITH 38HDR036

Temp (°F) Air Entering Condenser (Edb)	Air Entering Evaporator – Cfm/BF												
	640/0.02				740/0.02				840/0.03				
	Air Entering Evaporator – Ewb °F (°C)												
	57 (13.4)	62 (16.7)	67 (19.4)	72 (22.3)	57 (13.4)	62 (16.7)	67 (19.4)	72 (22.3)	57 (13.4)	62 (16.7)	67 (19.4)	72 (22.3)	
55	TCG	31.6	34.2	35.6	36.5	32.3	34.7	35.7	36.6	32.9	35.0	35.9	36.6
	SHG	30.5	27.2	22.6	18.1	32.3	28.2	22.9	18.2	32.9	29.0	23.3	18.4
	TC	30.9	33.5	34.9	35.7	31.6	34.0	35.0	35.8	32.2	34.3	35.1	35.9
	kW	1.74	1.74	1.75	1.74	1.74	1.75	1.75	1.74	1.73	1.75	1.75	1.74
	CMP	1.39	1.39	1.40	1.39	1.39	1.40	1.40	1.39	1.38	1.40	1.40	1.39
	LDB	43.8	48.1	54.0	59.7	45.2	50.0	56.1	61.5	47.6	51.8	57.8	62.9
65	LWB	40.0	45.4	51.6	58.1	41.5	47.0	53.3	59.6	42.7	48.3	54.6	60.8
	TCG	30.8	33.6	36.0	37.1	31.5	34.2	36.3	37.3	32.4	34.7	36.5	37.5
	SHG	30.0	27.1	23.1	18.6	31.4	28.4	23.8	18.9	32.4	29.4	24.4	19.1
	TC	30.0	32.8	35.2	36.4	30.8	33.5	35.6	36.5	31.7	34.0	35.8	36.8
	kW	1.95	1.94	1.95	1.95	1.95	1.94	1.95	1.95	1.95	1.95	1.95	1.95
	CMP	1.60	1.59	1.60	1.60	1.60	1.59	1.60	1.60	1.60	1.60	1.60	1.60
75	LDB	44.3	48.1	53.3	59.1	46.2	49.8	55.1	60.8	48.1	51.4	56.7	62.2
	LWB	40.6	45.8	51.4	57.8	41.9	47.2	53.0	59.3	43.0	48.4	54.3	60.5
	TCG	30.2	32.6	35.3	37.0	31.2	33.2	35.8	37.2	31.7	33.7	36.2	37.3
	SHG	29.0	26.7	22.9	18.7	29.7	28.1	23.8	19.0	31.7	29.2	24.5	19.3
	TC	29.4	31.8	34.5	36.3	30.5	32.4	35.0	36.4	31.0	33.0	35.4	36.6
	kW	2.18	2.17	2.17	2.18	2.18	2.18	2.17	2.18	2.18	2.17	2.18	2.18
85	CMP	1.83	1.82	1.82	1.83	1.83	1.83	1.82	1.83	1.83	1.82	1.83	1.83
	LDB	45.6	48.6	53.5	59.1	48.1	50.1	55.2	60.7	48.8	51.5	56.6	62.1
	LWB	40.9	46.4	51.8	57.9	42.1	47.7	53.2	59.4	43.3	48.9	54.4	60.6
	TCG	28.8	31.3	34.3	36.7	29.6	31.9	34.8	36.9	30.7	32.4	35.2	37.1
	SHG	28.2	26.0	22.7	18.5	29.6	27.4	23.6	19.0	30.7	28.8	24.4	19.4
	TC	28.0	30.5	33.5	35.9	28.9	31.2	34.1	36.2	30.0	31.7	34.5	36.4
95	kW	2.40	2.42	2.43	2.43	2.42	2.43	2.43	2.44	2.43	2.43	2.43	2.44
	CMP	2.05	2.07	2.08	2.08	2.07	2.08	2.08	2.09	2.08	2.08	2.08	2.09
	LDB	46.5	49.5	53.9	59.2	48.1	50.8	55.3	60.7	49.8	52.0	56.7	61.9
	LWB	41.8	47.1	52.3	58.1	43.0	48.4	53.7	59.5	43.8	49.5	54.8	60.6
	TCG	27.3	29.7	32.9	35.7	28.3	30.3	33.4	36.2	29.3	30.8	33.7	36.5
	SHG	27.3	25.1	22.0	18.3	28.3	26.5	23.0	18.8	29.3	27.8	23.9	19.3
105	TC	26.6	28.9	32.1	35.0	27.6	29.6	32.7	35.4	28.5	30.1	33.0	35.8
	kW	2.84	2.85	2.89	2.89	2.85	2.86	2.89	2.90	2.86	2.87	2.89	2.90
	CMP	2.49	2.50	2.54	2.54	2.50	2.51	2.54	2.55	2.51	2.52	2.54	2.55
	LDB	47.6	50.6	54.6	59.5	49.6	51.8	55.9	60.9	51.3	53.0	57.0	62.1
	LWB	42.7	48.0	53.0	58.5	43.7	49.2	54.3	59.8	44.5	50.2	55.3	60.8
	TCG	25.9	27.8	31.1	34.3	26.9	28.4	31.7	34.8	27.8	28.9	32.2	35.2
115	SHG	25.9	24.1	21.1	17.8	26.9	25.5	22.2	18.4	27.8	26.8	23.3	18.9
	TC	25.1	27.0	30.3	33.6	26.2	27.7	31.0	34.1	27.0	28.2	31.4	34.5
	kW	2.94	2.95	2.99	3.02	2.95	2.96	3.01	3.02	2.96	2.97	3.02	3.02
	CMP	2.59	2.60	2.64	2.67	2.60	2.61	2.66	2.67	2.61	2.62	2.67	2.67
	LDB	49.4	51.7	55.7	60.1	51.1	52.9	56.8	61.3	52.8	54.0	57.7	62.4
	LWB	43.6	49.0	53.9	59.1	44.5	50.1	55.0	60.3	45.2	51.0	56.0	61.3
125	TCG	24.4	25.7	29.0	32.5	25.3	26.3	29.6	33.0	26.2	27.4	29.9	33.4
	SHG	24.4	23.3	20.1	17.1	25.3	24.5	21.2	17.7	26.2	24.6	22.1	18.4
	TC	23.6	25.0	28.2	31.7	24.6	25.5	28.8	32.2	25.4	26.6	29.2	32.6
	kW	3.24	3.25	3.30	3.36	3.25	3.26	3.31	3.36	3.27	3.26	3.31	3.36
	CMP	2.89	2.90	2.95	3.01	2.90	2.91	2.96	3.01	2.92	2.91	2.96	3.01
	LDB	51.2	52.8	56.9	60.9	52.9	54.0	57.9	62.0	54.4	56.1	58.9	62.9
125	LWB	44.5	50.1	54.9	59.9	45.3	51.1	56.0	61.0	46.0	51.7	56.9	61.9
	TCG	22.8	23.9	26.6	30.2	23.6	24.8	27.1	30.7	24.4	25.2	27.6	31.1
	SHG	22.8	21.5	19.0	16.2	23.6	22.3	20.1	16.9	24.4	23.4	21.1	17.5
	TC	22.0	23.1	25.8	29.5	22.9	24.0	26.4	30.0	23.7	24.4	26.8	30.3
	kW	3.57	3.56	3.62	3.71	3.59	3.58	3.64	3.72	3.60	3.59	3.65	3.72
	CMP	3.22	3.21	3.27	3.36	3.24	3.23	3.29	3.37	3.25	3.24	3.30	3.37
125	LDB	53.2	55.0	58.2	61.9	54.8	56.4	59.0	62.8	56.2	57.4	59.8	63.7
	LWB	45.4	51.1	56.1	60.9	46.2	51.8	57.0	61.9	46.9	52.6	57.8	62.7

Rating Condition.

Not recommended for long-term operation

BF – Bypass Factor

CMP – Compressor

Edb – Entering Dry Bulb

Ewb – Entering Wet Bulb

kW – Total Power

LDB – Leaving Dry Bulb

LWB – Leaving Wet Bulb

SHG – Gross Sensible Capacity (1000 Btuh)

TC – Total Net Cooling Capacity (1000 Btuh)

TCG – Gross Cooling Capacity (1000 Btuh)

NOTES:

1. Direct interpolation is permissible. Do not extrapolate.
2. The SHG is based on 80°F edb temperature of air entering indoor coil.

Below 80°F edb, subtract (corr factor x cfm) from SHG.

Above 80°F edb, add (corr factor x cfm) to SHG.

Correction Factor = $1.10 \times (1 - BF) \times (edb - 80)$.

40QAC/QAC

PERFORMANCE DATA (CONT.)

COOLING CAPACITIES 40QAC048 WITH 38HDR048

Temp (°F) Air Entering Condenser (Edb)	Air Entering Evaporator – Cfm/BF												
	1100/0.05				1160/0.05				1200/0.06				
	Air Entering Evaporator – Ewb °F (°C)												
	57 (13.4)	62 (16.7)	67 (19.4)	72 (22.3)	57 (13.4)	62 (16.7)	67 (19.4)	72 (22.3)	57 (13.4)	62 (16.7)	67 (19.4)	72 (22.3)	
55	TCG	44.2	45.6	47.0	48.2	44.6	45.9	47.3	48.5	44.9	46.1	47.5	48.6
	SHG	44.2	36.9	30.7	25.4	44.6	37.5	31.1	25.6	44.9	38.0	31.3	25.8
	TC	43.0	44.5	45.9	47.1	43.4	44.8	46.2	47.3	43.7	45.0	46.3	47.5
	kW	2.42	2.42	2.42	2.42	2.42	2.42	2.42	2.42	2.42	2.42	2.42	2.42
	CMP	2.07	2.07	2.07	2.07	2.07	2.07	2.07	2.07	2.07	2.07	2.07	2.07
	LDB	42.5	49.1	54.8	59.7	44.7	50.7	56.2	60.9	46.0	51.7	57.1	61.6
65	LWB	40.1	46.4	52.7	59.0	41.2	47.5	53.7	60.0	41.9	48.1	54.3	60.5
	TCG	44.8	46.4	48.1	49.6	45.4	46.8	48.4	49.9	45.8	47.0	48.6	50.0
	SHG	44.8	38.7	31.9	26.1	45.4	39.6	32.4	26.3	45.8	40.1	32.7	26.5
	TC	43.7	45.3	47.0	48.5	44.3	45.7	47.3	48.7	44.6	45.9	47.5	48.9
	kW	2.74	2.75	2.75	2.76	2.74	2.75	2.75	2.76	2.74	2.75	2.75	2.76
	CMP	2.39	2.40	2.40	2.41	2.39	2.40	2.40	2.41	2.39	2.40	2.40	2.41
75	LDB	41.9	47.5	53.8	59.1	44.0	49.0	55.2	60.3	45.3	50.0	56.0	61.1
	LWB	39.8	46.0	52.3	58.6	40.9	47.1	53.3	59.6	41.6	47.8	54.0	60.2
	TCG	44.5	46.2	48.4	50.3	45.3	46.6	48.7	50.6	46.0	46.9	49.0	50.8
	SHG	44.5	39.6	32.6	26.5	45.3	40.6	33.3	26.8	46.0	41.3	33.7	27.1
	TC	43.4	45.0	47.2	49.2	44.1	45.5	47.6	49.4	44.9	45.7	47.8	49.6
	kW	3.08	3.10	3.12	3.12	3.09	3.10	3.12	3.12	3.09	3.11	3.12	3.12
85	CMP	2.73	2.75	2.77	2.77	2.74	2.75	2.77	2.77	2.74	2.76	2.77	2.77
	LDB	42.2	46.7	53.1	58.7	44.2	48.2	54.4	59.9	45.1	49.0	55.2	60.6
	LWB	39.9	46.1	52.2	58.4	41.0	47.2	53.2	59.4	41.5	47.9	53.8	59.9
	TCG	43.2	45.4	48.0	50.1	44.3	46.0	48.4	50.5	45.0	46.2	48.6	50.7
	SHG	43.2	39.8	33.0	26.6	44.3	41.2	33.8	27.0	45.0	42.1	34.3	27.3
	TC	42.1	44.3	46.8	49.0	43.1	44.8	47.2	49.3	43.9	45.0	47.4	49.5
95	kW	3.47	3.48	3.51	3.53	3.48	3.49	3.51	3.53	3.48	3.49	3.52	3.53
	CMP	3.12	3.13	3.16	3.18	3.13	3.14	3.16	3.18	3.13	3.14	3.17	3.18
	LDB	43.3	46.5	52.8	58.6	44.9	47.7	54.0	59.8	45.9	48.4	54.8	60.5
	LWB	40.5	46.4	52.3	58.4	41.4	47.4	53.3	59.4	41.9	48.1	54.0	60.0
	TCG	41.3	43.3	46.4	49.7	42.4	44.1	46.8	50.0	43.2	44.5	47.1	50.2
	SHG	41.3	38.9	32.7	26.6	42.4	40.7	33.5	27.1	43.2	41.7	34.2	27.4
105	TC	40.1	42.2	45.3	48.5	41.3	43.0	45.6	48.9	42.1	43.4	46.0	49.1
	kW	3.84	3.89	3.99	4.03	3.87	3.90	3.99	4.03	3.89	3.90	4.00	4.03
	CMP	3.49	3.54	3.64	3.68	3.52	3.55	3.64	3.68	3.54	3.55	3.65	3.68
	LDB	45.0	47.3	52.6	58.6	46.5	48.1	53.7	59.7	47.3	48.7	54.4	60.3
	LWB	41.4	47.3	52.6	58.6	42.1	48.1	53.6	59.5	42.6	48.7	54.2	60.1
	TCG	39.1	40.6	45.3	48.7	40.3	41.2	45.8	49.1	41.0	41.6	46.1	49.3
115	SHG	39.1	37.7	32.4	26.3	40.3	39.3	33.5	27.0	41.0	40.4	34.3	27.4
	TC	38.0	39.5	44.1	47.6	39.2	40.1	44.6	47.9	39.9	40.5	44.9	48.1
	kW	4.24	4.27	4.38	4.44	4.26	4.29	4.39	4.44	4.29	4.30	4.40	4.45
	CMP	3.89	3.92	4.03	4.09	3.91	3.94	4.04	4.09	3.94	3.95	4.05	4.10
	LDB	46.9	48.3	53.3	58.9	48.2	49.2	54.2	59.8	49.0	49.7	54.7	60.3
	LWB	42.4	48.3	53.3	58.9	43.0	49.2	54.2	59.8	43.4	49.7	54.7	60.3
125	TCG	36.6	37.3	42.1	46.8	37.8	38.0	42.6	47.4	38.6	38.6	43.0	47.7
	SHG	36.6	36.2	31.0	25.6	37.8	37.8	32.2	26.3	38.6	38.6	33.0	26.8
	TC	35.5	36.1	40.9	45.7	36.7	36.9	41.5	46.2	37.4	37.5	41.8	46.5
	kW	4.67	4.68	4.82	4.92	4.70	4.70	4.84	4.93	4.72	4.72	4.85	4.94
	CMP	4.32	4.33	4.47	4.57	4.35	4.35	4.49	4.58	4.37	4.37	4.50	4.59
	LDB	49.1	49.6	54.4	59.5	50.2	50.4	55.2	60.3	50.9	51.0	55.7	60.8
125	LWB	43.4	49.6	54.4	59.5	44.0	50.3	55.2	60.3	44.4	50.7	55.7	60.8
	TCG	34.0	34.1	38.6	43.4	35.1	35.1	39.3	44.1	35.8	35.8	39.7	44.5
	SHG	34.0	34.1	29.6	24.3	35.1	35.1	30.9	25.1	35.8	35.8	31.7	25.7
	TC	32.8	32.9	37.5	42.3	33.9	34.0	38.1	43.0	34.6	34.7	38.6	43.4
	kW	5.13	5.13	5.25	5.42	5.16	5.16	5.27	5.44	5.18	5.18	5.29	5.45
	CMP	4.78	4.78	4.90	5.07	4.81	4.81	4.92	5.09	4.83	4.83	4.94	5.10
125	LDB	51.4	51.4	55.6	60.5	52.4	52.5	56.3	61.2	53.1	53.2	56.7	61.6
	LWB	44.6	50.9	55.6	60.5	45.1	51.3	56.3	61.2	45.4	51.6	56.7	61.6

Rating Condition.

Not recommended for long-term operation

- BF – Bypass Factor
- CMP – Compressor
- Edb – Entering Dry Bulb
- Ewb – Entering Wet Bulb
- kW – Total Power
- LDB – Leaving Dry Bulb
- LWB – Leaving Wet Bulb
- SHG – Gross Sensible Capacity (1000 Btuh)
- TC – Total Net Cooling Capacity (1000 Btuh)
- TCG – Gross Cooling Capacity (1000 Btuh)

NOTES:

1. Direct interpolation is permissible. Do not extrapolate.
2. The SHG is based on 80°F edb temperature of air entering indoor coil.

Below 80°F edb, subtract (corr factor x cfm) from SHG.

Above 80°F edb, add (corr factor x cfm) to SHG.

Correction Factor = 1.10 x (1 - BF) x (edb - 80).

PERFORMANCE DATA (CONT.)

COOLING CAPACITIES 40QAC060 WITH 38HDR060

Temp (°F) Air Entering Condenser (Edb)	Air Entering Evaporator – Cfm/BF												
	1040/0.03				1220/0.04				1600/0.06				
	Air Entering Evaporator – Ewb °F (°C)												
	57 (13.4)	62 (16.7)	67 (19.4)	72 (22.3)	57 (13.4)	62 (16.7)	67 (19.4)	72 (22.3)	57 (13.4)	62 (16.7)	67 (19.4)	72 (22.3)	
55	TCG	58.3	60.6	62.3	64.9	59.9	61.5	63.7	65.4	62.0	62.6	64.4	65.8
	SHG	58.3	51.4	41.3	34.1	59.9	53.8	43.9	34.8	62.0	57.5	45.9	35.8
	TC	57.1	59.4	61.1	63.7	58.7	60.3	62.4	64.2	60.8	61.4	63.1	64.6
	kW	3.02	3.05	3.08	3.10	3.05	3.07	3.09	3.10	3.08	3.09	3.09	3.10
	CMP	2.67	2.70	2.73	2.75	2.70	2.72	2.74	2.75	2.73	2.74	2.74	2.75
	LDB	39.6	44.8	52.2	57.6	42.4	46.6	53.3	59.3	47.6	50.2	56.6	62.3
65	LWB	38.5	44.8	51.3	57.6	40.0	46.4	52.7	59.0	42.7	49.1	55.2	61.4
	TCG	57.1	60.3	63.8	65.4	58.9	61.6	64.4	66.3	62.6	63.4	64.9	66.7
	SHG	57.1	51.2	43.3	34.1	58.9	54.1	45.2	35.1	62.6	59.9	46.5	36.4
	TC	55.8	59.1	62.6	64.2	57.7	60.4	63.2	65.0	61.3	62.2	63.7	65.5
	kW	3.39	3.40	3.47	3.49	3.41	3.44	3.48	3.50	3.45	3.46	3.48	3.50
	CMP	3.04	3.05	3.12	3.14	3.06	3.09	3.13	3.15	3.10	3.11	3.13	3.15
75	LDB	40.5	44.9	50.9	57.6	43.1	46.4	52.4	59.1	47.3	48.9	56.4	62.0
	LWB	39.0	44.9	50.9	57.4	40.4	46.4	52.5	58.8	42.6	48.9	55.1	61.2
	TCG	55.3	58.5	63.4	66.6	57.2	59.5	64.8	67.1	60.6	61.4	66.1	67.6
	SHG	55.3	50.3	43.1	34.8	57.2	53.1	45.2	35.9	60.6	59.0	49.3	37.6
	TC	54.0	57.2	62.1	65.4	56.0	58.2	63.5	65.9	59.4	60.2	64.9	66.4
	kW	3.79	3.82	3.88	3.93	3.80	3.84	3.90	3.94	3.85	3.86	3.92	3.94
85	CMP	3.44	3.47	3.53	3.58	3.45	3.49	3.55	3.59	3.50	3.51	3.57	3.59
	LDB	41.8	45.5	51.0	57.1	44.2	47.0	52.4	58.6	48.4	49.4	54.9	61.3
	LWB	39.7	45.5	51.0	57.1	41.0	47.0	52.4	58.6	43.1	49.4	54.9	61.0
	TCG	53.0	55.8	61.3	66.0	55.0	57.2	62.2	66.5	58.7	59.1	63.7	67.4
	SHG	53.0	49.0	42.2	34.6	55.0	52.0	44.1	35.7	58.7	58.0	48.3	38.0
	TC	51.8	54.6	60.1	64.8	53.8	56.0	61.0	65.3	57.4	57.9	62.5	66.2
95	kW	4.19	4.25	4.31	4.39	4.24	4.27	4.34	4.40	4.29	4.29	4.36	4.42
	CMP	3.84	3.90	3.96	4.04	3.89	3.92	3.99	4.05	3.94	3.94	4.01	4.07
	LDB	43.4	46.4	51.6	57.3	45.5	47.7	53.1	58.8	49.4	49.9	55.4	61.1
	LWB	40.5	46.4	51.6	57.3	41.7	47.7	53.1	58.8	43.6	49.9	55.4	61.1
	TCG	50.6	52.8	55.3	63.4	52.6	54.0	56.5	64.4	56.0	56.1	58.3	66.4
	SHG	50.6	47.6	38.9	33.6	52.6	50.5	40.9	34.9	56.0	56.1	45.1	37.7
105	TC	49.4	51.5	54.1	62.2	51.4	52.7	55.3	63.1	54.8	54.9	57.0	65.2
	kW	4.62	4.67	4.96	5.05	4.67	4.71	4.97	5.07	4.77	4.77	5.00	5.09
	CMP	4.27	4.32	4.61	4.70	4.32	4.36	4.62	4.72	4.42	4.42	4.65	4.74
	LDB	45.1	47.4	52.6	58.0	47.1	48.7	53.8	59.3	50.8	50.9	55.9	61.3
	LWB	41.4	47.4	52.6	58.0	42.5	48.6	53.8	59.3	44.3	50.6	55.9	61.3
	TCG	47.6	49.2	54.5	60.3	49.8	49.8	55.6	61.4	53.1	53.2	57.4	63.0
115	SHG	47.6	45.9	39.2	32.4	49.8	49.8	41.4	33.7	53.1	53.2	45.8	36.4
	TC	46.4	47.9	53.3	59.1	48.5	48.6	54.3	60.1	51.9	52.0	56.2	61.7
	kW	5.07	5.11	5.27	5.39	5.14	5.14	5.31	5.41	5.23	5.24	5.35	5.45
	CMP	4.72	4.76	4.92	5.04	4.79	4.79	4.96	5.06	4.88	4.89	5.00	5.10
	LDB	47.2	48.6	53.6	58.8	48.9	49.1	54.8	60.0	52.4	52.5	56.7	61.9
	LWB	42.5	48.6	53.6	58.8	43.4	49.8	54.8	60.0	45.0	51.3	56.7	61.9
125	TCG	44.6	44.7	50.4	56.4	46.7	46.6	51.5	57.5	49.9	49.9	53.4	59.2
	SHG	44.6	44.7	37.6	30.9	46.7	46.6	39.7	32.3	49.9	49.9	44.2	35.1
	TC	43.4	43.5	49.2	55.2	45.5	45.4	50.3	56.3	48.6	48.7	52.1	58.0
	kW	5.59	5.60	5.73	5.93	5.66	5.65	5.76	5.97	5.74	5.74	5.84	5.99
	CMP	5.24	5.25	5.38	5.58	5.31	5.30	5.41	5.62	5.39	5.39	5.49	5.64
	LDB	49.3	49.4	54.8	59.8	50.9	51.1	55.8	60.8	54.1	54.2	57.5	62.6
125	LWB	43.5	49.9	54.8	59.8	44.3	50.7	55.8	60.8	45.9	52.0	57.5	62.6
	TCG	41.4	41.5	45.8	52.2	43.2	43.1	46.8	53.2	46.2	46.2	48.7	54.6
	SHG	41.4	41.5	35.7	29.4	43.2	43.1	37.8	30.7	46.2	46.2	42.3	33.4
	TC	40.2	40.2	44.6	51.0	42.0	41.9	45.6	51.9	44.9	45.0	47.4	53.4
	kW	6.15	6.15	6.25	6.43	6.21	6.19	6.28	6.47	6.28	6.28	6.34	6.55
	CMP	5.80	5.80	5.90	6.08	5.86	5.84	5.93	6.12	5.93	5.93	5.99	6.20
125	LDB	51.5	51.7	56.0	60.8	53.1	53.3	56.9	61.8	56.1	56.2	58.4	63.4
	LWB	44.7	51.0	56.0	60.8	45.4	51.7	56.9	61.8	46.8	52.9	58.4	63.4

Rating Condition.

Not recommended for long-term operation

BF – Bypass Factor

CMP – Compressor

Edb – Entering Dry Bulb

Ewb – Entering Wet Bulb

kW – Total Power

LDB – Leaving Dry Bulb

LWB – Leaving Wet Bulb

SHG – Gross Sensible Capacity (1000 Btuh)

TC – Total Net Cooling Capacity (1000 Btuh)

TCG – Gross Cooling Capacity (1000 Btuh)

NOTES:

1. Direct interpolation is permissible. Do not extrapolate.
2. The SHG is based on 80°F edb temperature of air entering indoor coil.

Below 80°F edb, subtract (corr factor x cfm) from SHG.

Above 80°F edb, add (corr factor x cfm) to SHG.

Correction Factor = $1.10 \times (1 - BF) \times (edb - 80)$.

40QAC/QAC

PERFORMANCE DATA (CONT.)

INSTANTANEOUS AND INTEGRATED HEATING RATINGS 40QAQ024 WITH 38QRR018

Air Temperature Entering Indoor Unit (°F)	Indoor Airflow (CFM) L-M-H	Item	Air Temperature Entering Outdoor Coil °F (°C)									
			17 (-8.3)		27 (-2.8)		37 (2.8)		47 (8.3)		57 (13.9)	
			Instant.	Integrated	Instant.	Integrated	Instant.	Integrated	Instant.	Integrated	Instant.	Integrated
			Rating	Rating	Rating	Rating	Rating	Rating	Rating	Rating	Rating	Rating
55	320	Cap	9.67	8.81	11.81	10.49	13.85	12.60	17.07	17.07	17.69	17.69
		kW	1.17		1.31		1.45		1.58		1.63	
	400	Cap	9.92	9.04	12.10	10.75	14.17	12.89	17.39	17.39	18.01	18.01
		kW	1.11		1.22		1.33		1.44		1.45	
	480	Cap	10.01	9.12	12.25	10.88	14.41	13.11	17.84	17.84	18.46	18.46
		kW	1.06		1.11		1.16		1.20		1.25	
60	320	Cap	9.56	8.72	11.84	10.52	13.67	12.44	16.82	16.82	17.56	17.56
		kW	1.22		1.29		1.37		1.44		1.49	
	400	Cap	9.74	8.88	11.99	10.65	14.00	12.74	17.22	17.22	17.95	17.95
		kW	1.16		1.22		1.28		1.33		1.38	
	480	Cap	9.84	8.97	12.06	10.71	14.14	12.87	17.53	17.53	17.99	17.99
		kW	1.12		1.17		1.21		1.26		1.30	
65	320	Cap	9.35	8.53	11.67	10.37	13.63	12.41	16.53	16.53	17.26	17.26
		kW	1.27		1.37		1.47		1.56		1.56	
	400	Cap	9.56	8.72	11.83	10.50	13.85	12.60	16.98	16.98	17.63	17.63
		kW	1.22		1.28		1.34		1.41		1.45	
	480	Cap	9.68	8.83	11.92	10.58	14.09	12.82	17.26	17.26	17.70	17.70
		kW	1.18		1.23		1.28		1.33		1.36	
70	320	Cap	9.15	8.35	11.45	10.17	13.38	12.18	16.45	16.45	16.94	16.94
		kW	1.33		1.41		1.48		1.55		1.65	
	400	Cap	9.37	8.55	11.70	10.39	13.66	12.43	16.70	16.70	17.50	17.50
		kW	1.28		1.34		1.41		1.48		1.52	
	480	Cap	9.50	8.66	11.84	10.52	13.88	12.63	17.00	17.00	17.70	17.70
		kW	1.24		1.29		1.35		1.40		1.44	
75	320	Cap	8.95	8.66	11.45	10.17	13.04	8.66	15.69	15.69	16.60	16.60
		kW	1.40		1.51		1.62		1.72		1.75	
	400	Cap	9.15	8.89	11.66	10.35	13.44	8.89	16.47	16.47	17.00	17.00
		kW	1.34		1.42		1.50		1.57		1.64	
	480	Cap	9.28	8.46	11.66	10.35	13.55	12.33	16.76	16.76	17.11	17.11
		kW	1.30		1.36		1.41		1.46		1.56	
80	320	Cap	8.71	7.94	11.21	9.96	13.07	11.90	15.32	15.32	15.91	15.91
		kW	1.46		1.54		1.62		1.70		1.97	
	400	Cap	8.91	8.13	11.45	10.17	13.20	12.01	15.45	15.45	16.37	16.37
		kW	1.41		1.47		1.53		1.59		1.96	
	480	Cap	9.09	8.66	11.59	10.30	13.40	12.20	15.65	15.65	16.57	16.57
		kW	1.36		1.43		1.51		1.58		1.76	

Rating Condition.

Integrated Rating

Cap – Heating Capacity (1000 Btuh), includes indoor fan motor heat.

kW – Total power input. Includes compressor motor power input, outdoor fan motor power input, and indoor fan motor power input.

NOTE: Integrated Capacity is maximum (instantaneous) capacity less the effect of frost on the outdoor coil and the heat to defrost it.

40QAC/QAQ

PERFORMANCE DATA (CONT.)

INSTANTANEOUS AND INTEGRATED HEATING RATINGS 40QAQ024 WITH 38QRR024

Air Temperature Entering Indoor Unit (°F)	Indoor Airflow (CFM) L-M-H	Item	Air Temperature Entering Outdoor Coil °F (°C)									
			17 (-8.3)		27 (-2.8)		37 (2.8)		47 (8.3)		57 (13.9)	
			Instant.	Integrated	Instant.	Integrated	Instant.	Integrated	Instant.	Integrated	Instant.	Integrated
			Rating	Rating	Rating	Rating	Rating	Rating	Rating	Rating	Rating	Rating
55	320	Cap	9.67	8.81	11.81	10.49	13.85	12.60	17.07	17.07	17.69	17.69
		kW	1.17		1.31		1.45		1.58		1.63	
	400	Cap	9.92	9.04	12.10	10.75	14.17	12.89	17.39	17.39	18.01	18.01
		kW	1.11		1.22		1.33		1.44		1.45	
	480	Cap	10.01	9.12	12.25	10.88	14.41	13.11	17.84	17.84	18.46	18.46
		kW	1.06		1.11		1.16		1.20		1.25	
60	320	Cap	9.56	8.72	11.84	10.52	13.67	12.44	16.82	16.82	17.56	17.56
		kW	1.22		1.29		1.37		1.44		1.49	
	400	Cap	9.74	8.88	11.99	10.65	14.00	12.74	17.22	17.22	17.95	17.95
		kW	1.16		1.22		1.28		1.33		1.38	
	480	Cap	9.84	8.97	12.06	10.71	14.14	12.87	17.53	17.53	17.99	17.99
		kW	1.12		1.17		1.21		1.26		1.30	
65	320	Cap	9.35	8.53	11.67	10.37	13.63	12.41	16.53	16.53	17.26	17.26
		kW	1.27		1.37		1.47		1.56		1.56	
	400	Cap	9.56	8.72	11.83	10.50	13.85	12.60	16.98	16.98	17.63	17.63
		kW	1.22		1.28		1.34		1.41		1.45	
	480	Cap	9.68	8.83	11.92	10.58	14.09	12.82	17.26	17.26	17.70	17.70
		kW	1.18		1.23		1.28		1.33		1.36	
70	320	Cap	9.15	8.35	11.45	10.17	13.38	12.18	16.45	16.45	16.94	16.94
		kW	1.33		1.41		1.48		1.55		1.65	
	400	Cap	9.37	8.55	11.70	10.39	13.66	12.43	16.70	16.70	17.50	17.50
		kW	1.28		1.34		1.41		1.48		1.52	
	480	Cap	9.50	8.66	11.84	10.52	13.88	12.63	17.00	17.00	17.70	17.70
		kW	1.24		1.29		1.35		1.40		1.44	
75	320	Cap	8.95	8.66	11.45	10.17	13.04	8.66	15.69	15.69	16.60	16.60
		kW	1.40		1.51		1.62		1.72		1.75	
	400	Cap	9.15	8.89	11.66	10.35	13.44	8.89	16.47	16.47	17.00	17.00
		kW	1.34		1.42		1.50		1.57		1.64	
	480	Cap	9.28	8.46	11.66	10.35	13.55	12.33	16.76	16.76	17.11	17.11
		kW	1.30		1.36		1.41		1.46		1.56	
80	320	Cap	8.71	7.94	11.21	9.96	13.07	11.90	15.32	15.32	15.91	15.91
		kW	1.46		1.54		1.62		1.70		1.97	
	400	Cap	8.91	8.13	11.45	10.17	13.20	12.01	15.45	15.45	16.37	16.37
		kW	1.41		1.47		1.53		1.59		1.96	
	480	Cap	9.09	8.66	11.59	10.30	13.40	12.20	15.65	15.65	16.57	16.57
		kW	1.36		1.43		1.51		1.58		1.76	

Rating Condition.

Integrated Rating

Cap - Heating Capacity (1000 Btuh), includes indoor fan motor heat.

kW - Total power input. Includes compressor motor power input, outdoor fan motor power input, and indoor fan motor power input.

NOTE: Integrated Capacity is maximum (instantaneous) capacity less the effect of frost on the outdoor coil and the heat to defrost it.

40QAC/QAQ

PERFORMANCE DATA (CONT.)

INSTANTANEOUS AND INTEGRATED HEATING RATINGS 40QAQ036 WITH 38QRR030

Air Temperature Entering Indoor Unit (F)	Indoor Airflow (CFM) L-M-H	Item	Air Temperature Entering Outdoor Coil (F)									
			17 (-8.3)		27 (-2.8)		37 (2.8)		47 (8.3)		57 (13.9)	
			Instant. Rating	Integrated Rating	Instant. Rating	Integrated Rating	Instant. Rating	Integrated Rating	Instant. Rating	Integrated Rating	Instant. Rating	Integrated Rating
55	630	Cap	16.44	14.99	20.75	18.43	23.89	21.74	28.90	28.90	32.23	32.23
		kW	1.92		2.01		2.10		2.20		2.29	
	750	Cap	16.60	15.13	20.84	18.51	24.57	22.36	29.08	29.08	32.39	32.39
		kW	1.87		1.91		1.94		1.98		2.08	
	870	Cap	16.86	15.37	21.19	18.82	24.94	22.69	29.38	29.38	32.65	32.65
		kW	1.83		1.85		1.86		1.88		1.96	
60	400	Cap	16.12	14.70	20.61	18.31	23.66	21.53	28.67	28.67	32.00	32.00
		kW	1.99		2.09		2.19		2.29		2.40	
	480	Cap	16.37	14.92	20.89	18.55	23.93	21.77	29.07	29.07	32.25	32.25
		kW	1.94		1.99		2.05		2.10		2.18	
	550	Cap	16.55	15.09	21.04	18.68	24.42	22.22	28.68	28.68	32.43	32.43
		kW	1.90		1.93		1.95		1.98		2.08	
65	400	Cap	15.53	14.16	20.30	18.03	22.84	20.79	27.99	27.99	30.79	30.79
		kW	2.10		2.21		2.32		2.44		2.62	
	480	Cap	16.06	14.64	20.62	18.31	23.74	21.61	28.79	28.79	31.67	31.67
		kW	2.01		2.08		2.15		2.22		2.31	
	550	Cap	16.21	14.78	20.80	18.47	24.13	21.96	29.13	29.13	32.05	32.05
		kW	1.97		2.01		2.06		2.10		2.22	
70	400	Cap	15.08	13.75	19.93	17.70	22.78	20.73	27.44	27.44	30.18	30.18
		kW	2.18		2.29		2.41		2.52		2.76	
	480	Cap	15.59	14.22	20.28	18.01	23.25	21.16	28.32	28.32	31.15	31.15
		kW	2.10		2.21		2.31		2.41		2.45	
	550	Cap	15.71	14.33	20.50	18.21	23.50	21.38	28.84	28.84	31.72	31.72
		kW	2.05		2.11		2.18		2.24		2.31	
75	400	Cap	14.79	8.66	19.57	17.38	22.47	8.66	26.91	26.91	29.60	29.60
		kW	2.23		2.35		2.46		2.57		2.80	
	480	Cap	15.10	8.89	19.89	17.67	22.56	8.89	27.54	27.54	30.29	30.29
		kW	2.19		2.28		2.38		2.47		2.59	
	550	Cap	15.41	14.05	20.13	17.87	23.13	21.05	28.33	28.33	31.17	31.17
		kW	2.13		2.21		2.28		2.35		2.45	
80	400	Cap	14.26	13.01	19.21	17.06	22.24	20.24	26.69	26.69	29.35	29.35
		kW	2.31		2.40		2.49		2.58		3.18	
	480	Cap	14.70	13.40	19.52	17.34	22.56	20.53	27.10	27.10	29.81	29.81
		kW	2.25		2.35		2.45		2.55		2.77	
	550	Cap	14.80	8.66	19.73	17.53	22.64	20.60	27.79	27.79	30.56	30.56
		kW	2.24		2.31		2.38		2.45		2.59	

Rating Condition.

Integrated Rating

Cap - Heating Capacity (1000 Btuh), includes indoor fan motor heat.

kW - Total power input. Includes compressor motor power input, outdoor fan motor power input, and indoor fan motor power input.

NOTE: Integrated Capacity is maximum (instantaneous) capacity less the effect of frost on the outdoor coil and the heat to defrost it.

40QAC/QAQ

PERFORMANCE DATA (CONT.)

INSTANTANEOUS AND INTEGRATED HEATING RATINGS 40QAQ036 WITH 38QRR036

Air Temperature Entering Indoor Unit (°F)	Indoor Airflow (CFM) L-M-H	Item	Air Temperature Entering Outdoor Coil °F (°C)									
			17 (-8.3)		27 (-2.8)		37 (2.8)		47 (8.3)		57 (13.9)	
			Instant.	Integrated	Instant.	Integrated	Instant.	Integrated	Instant.	Integrated	Instant.	Integrated
55	630	Cap	19.18	17.48	23.81	21.15	27.49	25.02	32.28	32.28	36.27	36.27
		kW	2.29		2.38		2.48		2.58		2.77	
	750	Cap	19.56	17.83	24.21	21.50	28.14	25.60	32.89	32.89	36.97	36.97
		kW	2.20		2.27		2.35		2.42		2.56	
	870	Cap	19.82	18.07	24.46	21.73	20.80	18.93	33.31	33.31	37.61	37.61
		kW	2.13		2.19		2.24		2.29		2.41	
60	400	Cap	18.73	17.08	23.41	20.79	19.96	18.17	31.71	31.71	35.66	35.66
		kW	2.39		2.51		2.63		2.75		2.90	
	480	Cap	19.15	17.46	23.84	21.17	19.43	17.68	23.22	23.22	36.48	36.48
		kW	2.29		2.25		2.21		2.16		2.69	
	550	Cap	19.44	17.72	24.13	21.43	18.84	17.15	19.34	19.34	37.10	37.10
		kW	2.23		2.15		2.06		1.98		2.53	
65	400	Cap	18.25	16.64	22.98	20.41	26.73	24.33	31.26	31.26	35.17	35.17
		kW	2.49		2.61		2.73		2.85		3.03	
	480	Cap	18.68	17.03	23.43	20.81	27.17	24.72	32.05	32.05	35.98	35.98
		kW	2.40		2.48		2.55		2.63		2.82	
	550	Cap	18.99	17.32	23.75	21.09	27.55	25.07	32.48	32.48	36.59	36.59
		kW	2.33		2.40		2.47		2.54		2.66	
70	400	Cap	17.73	16.16	22.50	19.98	26.34	23.97	30.75	30.75	34.49	34.49
		kW	2.59		2.71		2.83		2.95		3.27	
	480	Cap	18.18	16.58	23.00	20.43	26.82	24.40	31.59	31.59	35.53	35.53
		kW	2.51		2.58		2.66		2.74		3.00	
	550	Cap	18.51	16.87	23.33	20.72	27.12	24.68	32.00	32.00	36.09	36.09
		kW	2.44		2.51		2.59		2.67		2.79	
75	400	Cap	17.18	8.66	21.95	19.50	25.88	8.66	30.25	30.25	33.76	33.76
		kW	2.70		2.82		2.95		3.07		3.45	
	480	Cap	17.64	8.89	22.51	19.99	26.39	8.89	31.09	31.09	34.98	34.98
		kW	2.61		2.70		2.78		2.87		3.08	
	550	Cap	17.98	16.40	22.89	20.33	26.73	24.32	31.60	31.60	35.57	35.57
		kW	2.54		2.61		2.67		2.74		2.93	
80	400	Cap	16.60	15.13	21.38	18.99	25.41	23.12	29.68	29.68	33.34	33.34
		kW	2.80		2.93		3.06		3.19		3.55	
	480	Cap	17.07	15.57	21.95	19.49	25.94	23.60	30.37	30.37	34.42	34.42
		kW	2.72		2.83		2.93		3.04		3.31	
	550	Cap	17.42	8.66	22.37	19.86	26.32	23.95	31.09	31.09	35.07	35.07
		kW	2.65		2.73		2.80		2.87		3.11	

Rating Condition.

Integrated Rating

Cap - Heating Capacity (1000 Btuh), includes indoor fan motor heat.

kW - Total power input. Includes compressor motor power input, outdoor fan motor power input, and indoor fan motor power input.

NOTE: Integrated Capacity is maximum (instantaneous) capacity less the effect of frost on the outdoor coil and the heat to defrost it.

40QAC/QAQ

PERFORMANCE DATA (CONT.)

INSTANTANEOUS AND INTEGRATED HEATING RATINGS 40QAQ048 WITH 38QRR048

Air Temperature Entering Indoor Unit (°F)	Indoor Airflow (CFM) L-M-H	Item	Air Temperature Entering Outdoor Coil °F (°C)									
			17 (-8.3)		27 (-2.8)		37 (2.8)		47 (8.3)		57 (13.9)	
			Instant. Rating	Integrated Rating	Instant. Rating	Integrated Rating	Instant. Rating	Integrated Rating	Instant. Rating	Integrated Rating	Instant. Rating	Integrated Rating
55	820	Cap	27.65	25.21	33.34	29.61	38.58	35.11	45.46	45.46	50.81	50.81
		kW	3.24		3.44		3.64		3.84		4.14	
	975	Cap	28.09	25.61	33.91	30.12	39.36	35.81	46.08	46.08	51.85	51.85
		kW	3.12		3.28		3.44		3.60		3.86	
	1130	Cap	28.52	26.01	34.32	30.48	39.76	36.19	46.61	46.61	52.82	52.82
		kW	3.03		3.17		3.30		3.43		3.66	
60	820	Cap	27.09	24.70	32.79	29.12	38.22	34.78	44.77	44.77	50.24	50.24
		kW	3.39		3.59		3.80		4.00		4.32	
	975	Cap	27.62	25.18	33.40	29.67	38.90	35.40	45.56	45.56	51.24	51.24
		kW	3.27		3.44		3.60		3.77		4.04	
	1130	Cap	27.99	25.52	33.80	30.02	39.32	35.78	46.08	46.08	51.94	51.94
		kW	3.17		3.32		3.46		3.60		3.83	
65	820	Cap	26.49	24.15	32.21	28.60	37.67	34.28	44.22	44.22	49.61	49.61
		kW	3.53		3.74		3.96		4.17		4.50	
	975	Cap	27.03	24.64	32.83	29.16	38.37	34.92	45.02	45.02	50.60	50.60
		kW	3.41		3.59		3.77		3.95		4.22	
	1130	Cap	27.41	24.99	33.26	29.54	38.83	35.33	45.55	45.55	51.32	51.32
		kW	3.32		3.47		3.62		3.77		4.01	
70	820	Cap	25.86	23.58	31.59	28.05	37.08	33.74	43.67	43.67	48.91	48.91
		kW	3.67		3.89		4.12		4.35		4.68	
	975	Cap	26.42	24.09	32.23	28.63	37.80	34.40	44.50	44.50	49.98	49.98
		kW	3.55		3.74		3.94		4.13		4.41	
	1130	Cap	26.80	24.43	32.67	29.02	38.28	34.84	45.01	45.01	50.68	50.68
		kW	3.46		3.63		3.79		3.95		4.20	
75	820	Cap	25.21	8.66	30.94	27.48	36.46	8.66	43.29	43.29	48.29	48.29
		kW	3.81		4.05		4.30		4.54		4.87	
	975	Cap	25.77	8.89	31.59	28.06	37.20	8.89	44.18	44.18	49.33	49.33
		kW	3.70		3.90		4.11		4.32		4.60	
	1130	Cap	26.16	23.85	32.05	28.47	37.70	34.31	44.53	44.53	50.03	50.03
		kW	3.61		3.79		3.96		4.14		4.40	
80	820	Cap	24.50	22.34	30.26	26.87	35.81	32.59	42.95	42.95	47.61	47.61
		kW	3.95		4.21		4.47		4.73		5.06	
	975	Cap	25.08	22.86	30.92	27.46	36.56	33.27	43.74	43.74	48.63	48.63
		kW	3.84		4.06		4.29		4.51		4.80	
	1130	Cap	25.46	8.66	31.39	27.88	37.08	33.74	44.22	44.22	49.36	49.36
		kW	3.76		3.95		4.14		4.33		4.59	

Rating Condition.

Integrated Rating

Cap - Heating Capacity (1000 Btuh), includes indoor fan motor heat.

kW - Total power input. Includes compressor motor power input, outdoor fan motor power input, and indoor fan motor power input.

NOTE: Integrated Capacity is maximum (instantaneous) capacity less the effect of frost on the outdoor coil and the heat to defrost it.

40QAQ/QAQ

PERFORMANCE DATA (CONT.)

INSTANTANEOUS AND INTEGRATED HEATING RATINGS 40QAQ060 WITH 38QRR060

Air Temperature Entering Indoor Unit (°F)	Indoor Airflow (CFM) L-M-H	Item	Air Temperature Entering Outdoor Coil °F (°C)									
			17 (-8.3)		27 (-2.8)		37 (2.8)		47 (8.3)		57 (13.9)	
			Instant.	Integrated	Instant.	Integrated	Instant.	Integrated	Instant.	Integrated	Instant.	Integrated
55	1040	Cap	31.97	29.15	38.41	34.12	42.34	38.53	53.78	53.78	57.10	57.10
		kW	3.73		3.87		4.02		4.16		4.26	
	1220	Cap	32.33	29.48	39.03	34.67	42.99	39.12	54.83	54.83	58.41	58.41
		kW	3.62		3.76		3.89		4.03		4.14	
	1600	Cap	32.89	29.99	39.62	35.18	43.44	39.53	55.52	55.52	59.30	59.30
		kW	3.44		3.55		3.65		3.76		3.84	
60	1040	Cap	31.21	28.46	37.64	33.43	41.36	37.64	52.67	52.67	55.60	55.60
		kW	3.85		4.00		4.15		4.31		4.40	
	1220	Cap	31.81	29.00	38.50	34.20	42.51	38.68	54.28	54.28	57.69	57.69
		kW	3.76		3.91		4.06		4.21		4.31	
	1600	Cap	32.37	29.52	39.16	34.78	43.10	39.23	55.05	55.05	58.69	58.69
		kW	3.59		3.70		3.82		3.94		4.02	
65	1040	Cap	30.58	27.88	36.98	32.85	40.71	37.04	51.95	51.95	55.16	55.16
		kW	4.01		4.17		4.33		4.48		4.60	
	1220	Cap	31.26	28.50	37.93	33.69	41.93	38.16	53.82	53.82	57.17	57.17
		kW	3.90		4.06		4.22		4.38		4.49	
	1600	Cap	31.81	29.01	38.60	34.28	42.72	38.88	54.54	54.54	58.11	58.11
		kW	3.73		3.86		3.98		4.11		4.20	
70	1040	Cap	30.11	27.46	36.27	32.21	39.96	36.36	51.01	51.01	54.24	54.24
		kW	4.19		4.35		4.50		4.65		4.77	
	1220	Cap	30.64	27.94	37.29	33.12	41.26	37.54	53.08	53.08	56.57	56.57
		kW	4.05		4.22		4.39		4.55		4.68	
	1600	Cap	31.22	28.46	37.97	33.72	42.06	38.27	54.03	54.03	57.51	57.51
		kW	3.88		4.02		4.16		4.30		4.39	
75	1040	Cap	29.34	8.66	35.76	31.76	39.08	8.66	49.96	49.96	53.15	53.15
		kW	4.36		4.51		4.67		4.83		4.95	
	1220	Cap	29.93	8.89	36.60	32.51	40.51	8.89	52.18	52.18	55.80	55.80
		kW	4.20		4.38		4.55		4.72		4.86	
	1600	Cap	30.55	27.85	37.27	33.10	41.35	37.63	53.38	53.38	56.87	56.87
		kW	4.01		4.17		4.32		4.48		4.58	
80	1040	Cap	28.69	26.16	35.12	31.19	38.17	34.74	48.75	48.75	51.91	51.91
		kW	4.54		4.69		4.85		5.00		5.12	
	1220	Cap	29.22	26.64	35.82	31.82	39.52	35.97	51.08	51.08	54.65	54.65
		kW	4.38		4.55		4.71		4.88		5.02	
	1600	Cap	29.82	8.66	36.52	32.44	40.52	36.87	52.37	52.37	56.17	56.17
		kW	4.16		4.32		4.49		4.65		4.77	

Rating Condition.
Integrated Rating

Cap - Heating Capacity (1000 Btuh), includes indoor fan motor heat.

kW - Total power input. Includes compressor motor power input, outdoor fan motor power input, and indoor fan motor power input.

NOTE: Integrated Capacity is maximum (instantaneous) capacity less the effect of frost on the outdoor coil and the heat to defrost it.

40QAC/QAQ

PERFORMANCE DATA (CONT.)

Fresh Air and Ducting

The ceiling-suspended fan coil units may bring in up to 30% fresh air. The percentage of air allowable is calculated based on the unit high speed CFM. Air quantities above this level may exceed

compressor maximum saturated suction temperatures. A power ventilation kit is available to overcome ventilation duct static. See Power Ventilation Kit Available Static Pressure table below.

POWER VENTILATION KIT AVAILABLE STATIC PRESSURE

FAN HP	WATTS	RPM	VOLT-AGE	CFM AT STATIC PRESSURE							DUCT DIA. (In.)	
				0	1/8	1/4	3/8	1/2	3/4	1		1-1/2
1/15	150	2700	208/230	370	335	318	298	256	219	189	112	6

SYSTEM OPERATING CONDITIONS OPERATING LIMITS

FAN COIL UNITS	TEMP
CONDITION	
Maximum Room Temperature (F)	84
Minimum Room Temperature (F)	64
Maximum Return Air (F)	
Dry-Bulb	85
Wet-Bulb	72
Minimum Return Air (°F) (Heat Pump)	28

40QAC/QAQ

ELECTRICAL DATA

UNIT	VOLTAGE V-Ph-60 Hz	VOLTAGE		FAN FLA	HEATER		POWER			MINIMUM WIRE SIZE (AWG)
		MIN.	MAX.		kW	FLA	MCA	MOCP	FLA	
40QAC024-3	208/230-1	187	253	0.50	—	—	0.63	15.0	0.50	14
40QAC036-3	208/230-1	187	253	1.30	—	—	1.60	15.0	1.30	14
40QAC048-3	208/230-1	187	253	1.60*	—	—	2.00	15.0	1.60	14
40QAC060-3	208/230-1	187	253	2.60†	—	—	3.30	15.0	2.60	14
40QAQ024-3	208/230-1	187	253	0.50	2.00	8.66	9.29	15.0	11.29	14
40QAQ036-3	208/230-1	187	253	1.30	3.00	13.00	17.70	20.0	14.30	14
40QAQ048-3	208/230-1	187	253	1.60*	4.00	17.40	23.80	25.0	19.00	12
40QAQ060-3	208/230-1	187	253	2.60†	5.00	21.70	28.70	30.0	24.30	10

LEGEND:

- AWG – American Wire Gage
- FLA – Full Load Amps
- LRA – Locked Rotor Amps
- MCA – Minimum Circuit Amps
- MOCP – Maximum Overcurrent Protection Amps (Fuse or HACR)

* One fan is 1.1 amps, the second fan is 0.5 amps.

† Two fans each operating at 1.3 amps.



TYPICAL WIRING SCHEMATICS

- LEGEND**
- ASM — Air Sweep Motor
 - ASR — Air Sweep Relay
 - ASW — Air Sweep Switch
 - C — Contactor
 - CAP — Capacitor
 - COMP — Compressor
 - CR — Control Relay
 - CT — Current Transformer
 - DR — Delay Relay
 - EQUIP — Equipment Ground
 - GND — Equipment Ground
 - FL — Fuse Link
 - FPT — Freeze Protection Thermostat
 - FR — Fan Relay
 - FU — Fuse
 - HP — Heat Pump
 - HPS — High-Pressure Switch
 - HR — Heater Relay
 - HTR — Heater
 - HTT — Heater Temp Thermostat
 - IFM — Indoor Fan Motor
 - LPS — Low-Pressure Switch
 - OFM — Outdoor-Fan Motor
 - OL — Overload
 - PDR — Pump Delay Relay
 - PL — Plug
 - PM — Pump Motor
 - PSS — Pump Shut-off Switch
 - TB — Terminal Block
 - TRAN — Transformer

- Terminal (Marked)
- Terminal (unmarked)
- Splice
- Terminal Block
- Factory Wiring
- Field Control Wiring
- Field Power Wiring
- Printed Circuit Board
- Accessory or Optional Wiring

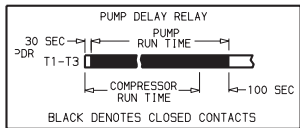
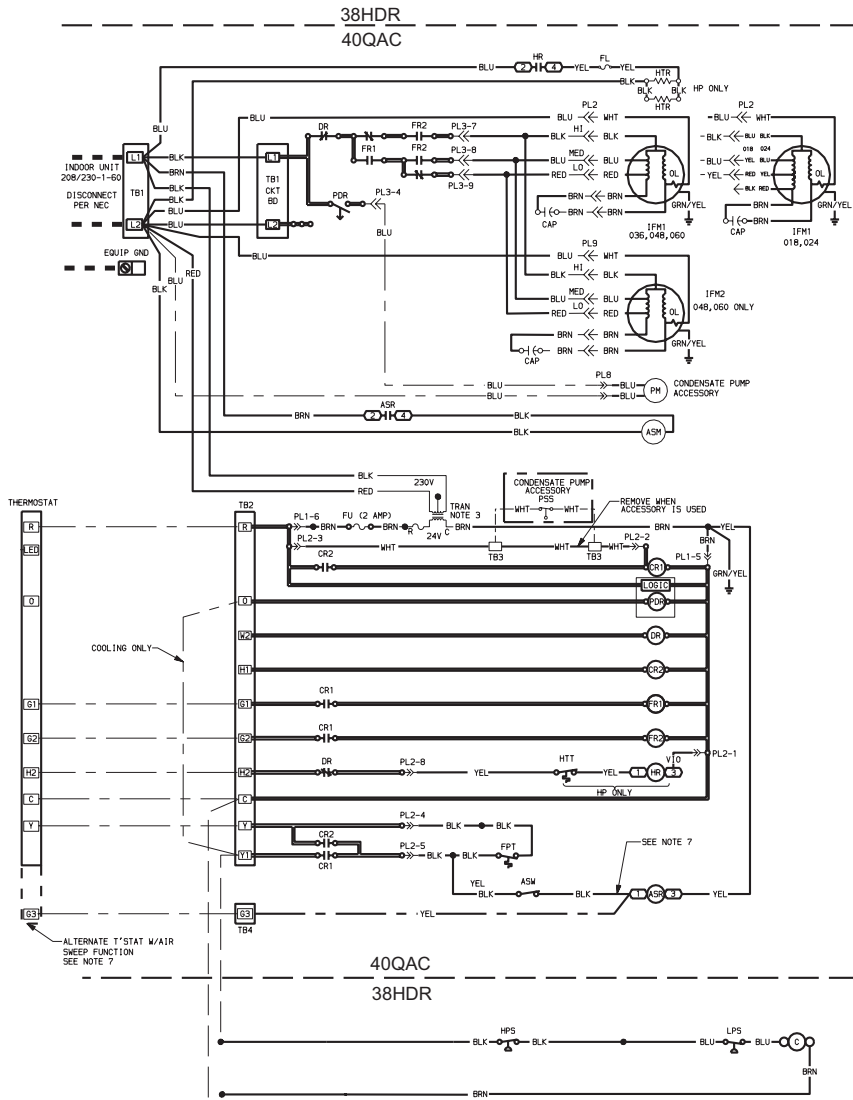
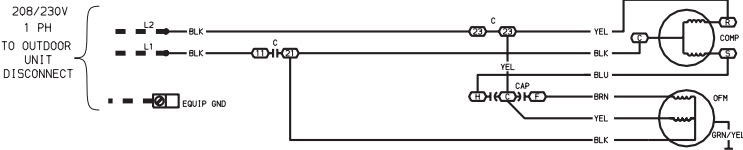

NOTES:

1. If any of the original wire furnished must be replaced, it must be replaced with type 90° C wire or its equivalent.
2. Wire in accordance with National Electrical Code, NEC) and all local codes.
3. Transformer is thermally protected and will reset automatically.
4. IFMs, OFM and COMP have internal thermal protection.
5. When using thermostat with air sweep function:
 - Yellow wire from G3 to be connected to ASR1.
 - Black wire to be disconnected from ASR1.
 - Leave black wire tie-wrapped to yellow wire.

RELAY CHART		
INDOOR FAN	HIGH	FR2
INDOOR FAN	MED	FR1, FR2
INDOOR FAN	LOW	FR1

40QC/QAC

TYPICAL WIRING SCHEMATICS (CONT.)

40QAC/QAQ

- LEGEND**
- ASM — Air Sweep Motor
 - ASR — Air Sweep Relay
 - C — Contactor
 - CAP — Capacitor
 - COMP — Compressor
 - CR — Control Relay
 - CT — Current Transformer
 - DFB — Defrost Board (Outdoor Unit)
 - DFT — Defrost Thermostat
 - DR — Delay Relay
 - DTS — Discharge Temp. Sensor
 - EQUIP. GND — Equipment Ground
 - FL — Fuse Link
 - FPT — Freeze Protection Thermostat
 - FR — Fan Relay
 - FU — Fuse
 - HP — Heat Pump
 - HPS — High-Pressure Switch
 - HR — Heater Relay
 - HTR — Heater
 - HTT — Heater Temp Thermostat
 - IFM — Indoor Fan Motor
 - LPS — Low-Pressure Switch
 - OFM — Outdoor-Fan Motor
 - OL — Overload
 - PDR — Pump Delay Relay
 - PL — Plug
 - PM — Pump Motor
 - PSS — Pump Shut-off Switch
 - RVS — Reversing Valve Solenoid
 - SSDR — Safety Switch Delay Relay
 - TB — Terminal Block
 - TRAN — Transformer

- Terminal (Marked)
- Terminal (unmarked)
- Splice
- Terminal Block
- Factory Wiring
- Field Control Wiring
- Field Power Wiring
- Printed Circuit Board
- Accessory or Optional Wiring

NOTES:

1. If any of the original wire furnished must be replaced, it must be replaced with type 90° C wire or its equivalent.
2. Wire in accordance with National Electrical Code, NEC and all local codes.
3. Transformer is thermally protected and will reset automatically.
4. IFMs, OFM and COMP have internal thermal protection.
5. When using thermostat with air sweep function:
 - Yellow wire from G3 to be connected to ASR1.
 - Black wire to be disconnected from ASR1.
 - Leave black wire tie-wrapped to yellow wire.

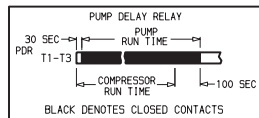
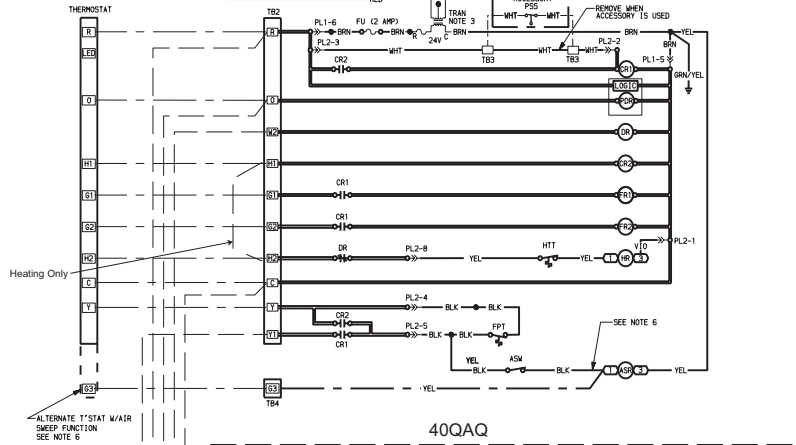
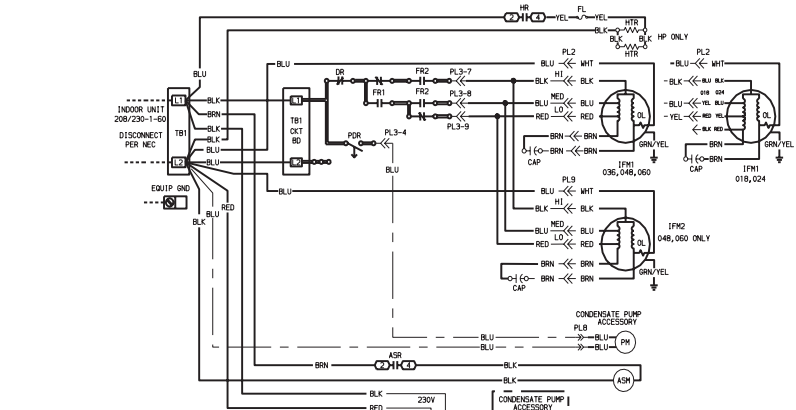
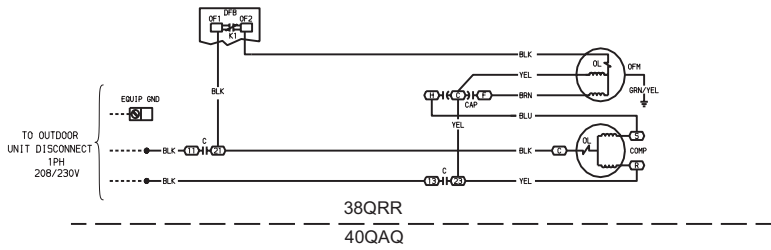

RELAY CHART	
INDOOR FAN HIGH	FR2
INDOOR FAN MED	FR1, FR2
INDOOR FAN LOW	FR1

38QRR and 40QAA Heat Pump System Wiring Diagram

TYPICAL PIPING AND WIRING

TYPICAL INSTALLATION – CEILING-SUSP ENDED SYSTEMS

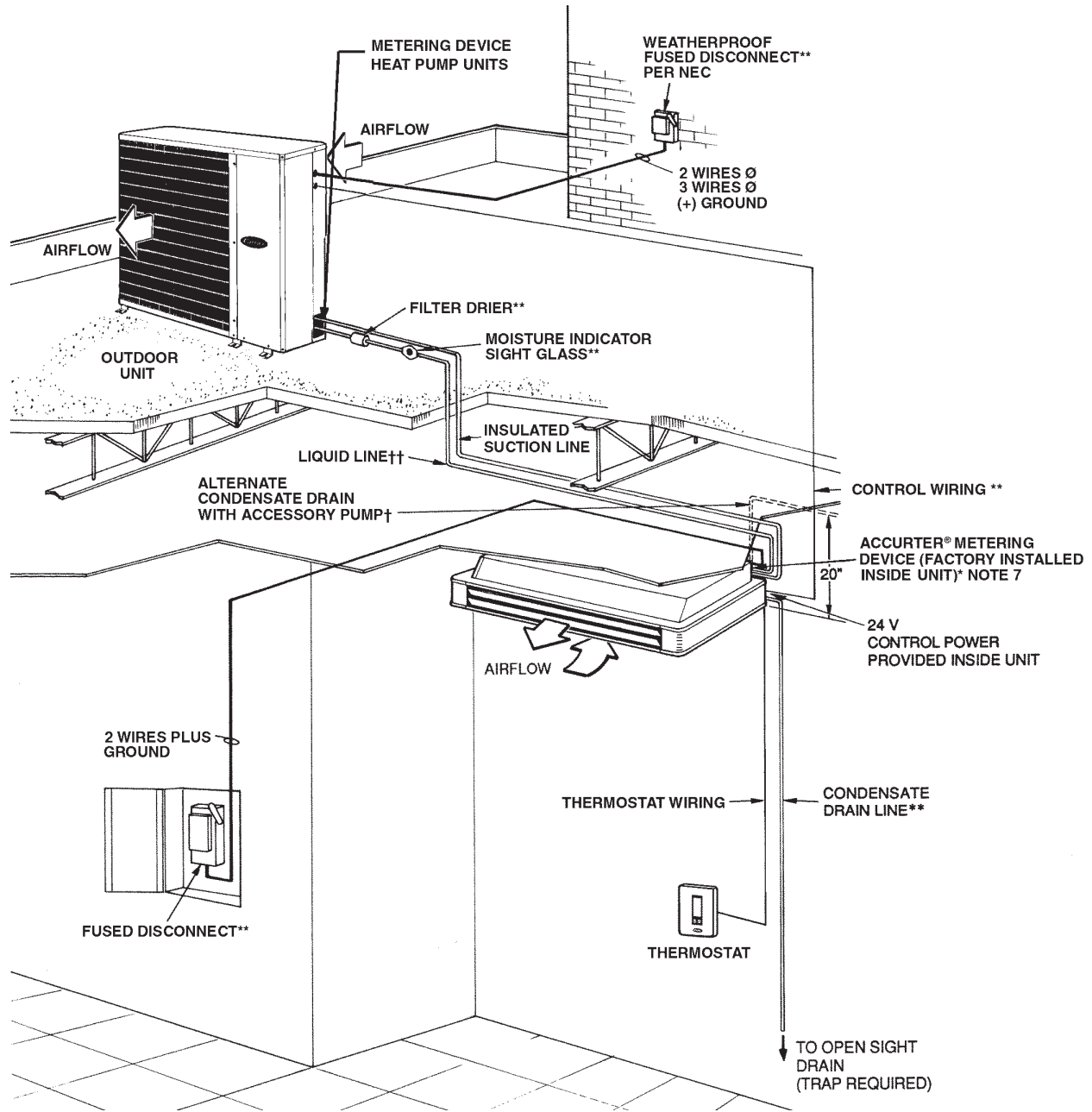

LEGEND

- Phase
- NEC
- National Electrical Code
- Piping
- Line Voltage
- 24 V
- Thermistor

- *Standard.
- †Accessory item.
- **Field supplied.
- ††Insulate for heat pump application.

NOTES:

1. All piping must follow standard refrigerant piping techniques.
2. All wiring must comply with the applicable local and national codes.
3. Liquid line need not be insulated on cooling unit.
4. Wiring and piping shown are general points-of-connection guides only and are not intended for a specific installation.
5. Insulate condensate drain if run above a conditioned space.
6. AccuRater® device is provided.
7. Check piston/charge chart for proper piston size depending on condenser match.

40QAC/QAQ

CONTROLS

Sequence of Operation

Automatic air sweep

All under-ceiling units are equipped with an automatic air sweep feature, which automatically directs the airflow louvers up and down to provide optimum room air circulation. If the automatic sweep feature is not desired, temporarily start the automatic sweep using the toggle switch on the unit. When the louvers are in the desired position, turn the automatic sweep off to hold them in that position.

Operating sequence

Ceiling-suspended fan coil units have a relay board which controls system operation in response to the room thermostat. The user may manually select any one of 3 fan speeds for unit operation. Ceiling suspended systems may be equipped with an accessory power ventilation kit and/or condensate pump.

Duct-free splits thermostat operation

Operating mode memory

After the system is turned off or after a power failure the system remains in the last operating mode selected. When the system is turned back on, or when power is automatically restored, operation continues in the same operating mode as when the system shut down.

Automatic operation (auto) mode

If Auto. mode is selected, the system automatically switches over the operating mode from heating to cooling, or from cooling to heating depending on the selected temperature. Auto. mode also controls fan speed if not manually overridden.

Fan operation

Fan speed can be selected by pressing the fan button (either high, medium, or low speed). The fan is capable of operation when unit mode is set on cooling, heating, or auto. mode. When the fan is operating in medium or high speed and the unit is equipped with the power ventilation kit, the ventilation fan will operate to provide fresh air.

Increased demand for cooling (heat pump systems)

1. When the room thermostat senses a demand for cooling, the fan coil relay board is energized and the indoor fan will start in the selected speed (if it is not already operating).
2. The reversing valve is energized at all times when in cooling mode.
3. The internal condensate pump (if so equipped) runs whenever the reversing valve is energized. The internal condensate pump (if so equipped) runs whenever there is a demand for cooling.
4. As long as the condensate float switch and freeze protection thermostat are closed, the cooling relays in the fan coil unit will close. This energizes the compressor and outdoor fan in the outdoor unit. The compressor will continue to operate until the room thermostat is satisfied.
5. When the cooling demand is satisfied, the compressor and outdoor fan will stop. If the system is in Auto. mode, the indoor fan will stop with the compressor. If the unit has the accessory ventilation kit, the ventilation fan will operate whenever the indoor fan is set for medium or high speed.

Increased demand for heating (heat pump systems)

1. When the room thermostat senses a demand for heating, the fan coil relay board is energized .
2. The indoor fan will start in the selected speed (if it is not already operating). The reversing valve will not be energized. The internal condensate pump (if supplied) and freeze protection thermostat are not operated during heating operation.
3. The control relay closes, and the compressor and outdoor fan are energized through the defrost and the defrost timer runs.
4. Once every 90 minutes (the factory default setting) of the compressor run time, the DFB (defrost board) logic checks the defrost thermostat (DFT). If the DFT is open, the unit continues in heating operation. If the DFT is closed, the DFB switches the unit to defrost mode. The timing on the DFB may be set at either 30, 50 or 90 minutes.

Defrost

The DFB energizes the RVS (reversing valve solenoid), and the reversing valve switches to the cooling position. The relay on the DFB opens and the outdoor fan stops. The contact on the DFB is also energized, which in turn energizes the defrost relay on the fan coil relay board, turns off the electric heater and stops the indoor fan. The DFB logic checks the 10-minute defrost timer and the DFT. If the DFT opens in less than 10 minutes, the defrost board switches the unit back to normal heating operation. If the DFT remains closed the DFB switches the unit back to heating operation after 10 minutes. When the DFB changes back to heating mode, the RVR (reversing valve relay) is deenergized and the reversing valve switches back to heating operation. Both the outdoor and indoor fans come back on, and if necessary, the electric heater also turns on.

System safeties

The system is equipped with the following safety devices to protect system components:

- Indoor coil freeze protection thermostat (cooling cycle only). If a coil temperature of 28°F or lower is sensed, the compressor and outdoor fan will be shut down until the coil temperature exceeds 28°F. The indoor fan will continue to run.
- Condensate float switch (units equipped with accessory condensate pump, cooling cycle only).

If the level of condensate in the drain pan rises too high the condensate float switch will turn off the compressor and outdoor fan until the condensate level returns to normal. The indoor fan will continue to run.

Special operation heat mode

Outdoor cooling units can be matched with heat pump ceiling-suspended fan coil units to provide supplemental electric heat. All other operation is the same as a cooling only system, except these units have the following heating capability:

- When the room thermostat initiates a call for heating, the electric heater is turned on.
- The indoor unit fan will start at the same time if it was not already operating.
- When the heating requirement is satisfied, the room thermostat will open and the heater will turn off.

GUIDE SPECIFICATIONS

40QAC/QAQ CEILING-SUSPENDED COOLING ONLY UNITS

Commercial Air-Cooled Condensing Units

HVAC Guide Specifications

Size Range: 2 to 5 Tons, Cooling Capacity

Part 1 - General

1.01 SYSTEM DESCRIPTION

Indoor, direct expansion, ceiling-suspended fan coil.

1.02 QUALITY ASSURANCE

- A. Systems shall be rated and certified in accordance with ARI Standards 210/240. Units shall be listed in the ARI directory as a matched set.
- B. Systems shall be listed with UL (Underwriters' Laboratories) and UL, Canada.

1.03 DELIVERY, STORAGE, and HANDLING

Units shall be shipped in one piece and shall be stored and handled per unit manufacturer's recommendations.

1.04 WARRANTY

The 40QA unit is covered by a 1-year parts warranty.

Part 2 - Products

2.01 EQUIPMENT

A. General:

Indoor, direct-expansion, ceiling-suspended fan coil. Fan coil shall be shipped complete with cooling coil, fan, fan motor, piping connectors, and ceiling mounting brackets.

B. Unit Cabinet:

1. Unit cabinet shall be zinc-coated bonderized steel finished with a baked enamel paint.
2. Inlet grilles shall be attractively styled, high impact polystyrene.
3. Matching mounting brackets shall be provided.

C. Fans:

1. Indoor fans shall be 3-speed centrifugal blower type with air intake in the bottom rear of the unit and discharge in the front.
2. Automatic, motor-driven horizontal air sweep shall be provided standard.

D. Coils:

1. Indoor coils shall be copper tube with aluminum fins and galvanized steel tube sheets.
2. Fins shall be bonded to the tubes by mechanical expansion.
3. A drip pan under the coil shall have a drain connection for the hose attachment to remove condensate.

E. Motors:

Motors shall be a permanently lubricated ball bearing with inherent overload protection.

F. Refrigeration Components (Condenser):

Refrigerant circuit components shall include brass external vapor supply line service valve(s), vapor return line service valve(s) with service gage connection port, service gage port connections on compressor suction and discharge lines with Schrader type fittings (located at outdoor unit).

G. Filters:

Unit shall have filter track with field-supplied cleanable filters.

H. Thermostat Controls:

1. Automatic restart after power failure at the same operating conditions as at failure.
2. Thermostat control to enter set points and operating conditions.

3. Cooling mode to provide modulating fan speed based on the difference between temperature setpoint and space temperature.
4. Fan-only operation to provide room air circulation when no cooling is required.
5. Fan speed control shall be user-selectable: high, medium, low, or automatic operation during all operating modes.
6. A time delay shall prevent compressor restart in less than 2 to 4 minutes.
7. Automatic heating-to-cooling changeover to provide automatic heating and cooling operation. Control shall include deadband to prevent rapid mode cycling.

NOTE: See selected thermostat instructions for further information.

I. Electrical Requirements:

1. Unit shall operate on single-phase, 60 cycle power at 208/230v as specified on the equipment schedule.
2. Unit electrical power shall be a single point connection.
3. Unit control voltage shall be 24-v. All power and control wiring shall be installed per NEC and all local building codes.
4. Unit shall have low-voltage terminal block connections.

J. Special Features (Field Installed):

1. Internal Condensate Pump:

The condensate pump shall remove condensate from the drain pan when gravity drainage cannot be used. The lift capability of the condensate pump shall be direct vertical 20 inches. Float control shall be in the condensate sump to shut the unit down in case of a pump malfunction.

2. Fresh Air Intake kit:

The fresh air intake kit shall include the filter and duct connections to provide for outdoor ventilation air.

3. Power Ventilation Kit:

The power ventilation kit shall be used with the accessory fresh air kit when fresh air must be ducted in. The kit will overcome duct static to provide a constant supply of ventilation air. The kit consists of booster fan and adjustable speed control to properly balance the fan to achieve the required airflow rate.

4. Slim Line Thermostat:

The Slim Line thermostat shall incorporate 3-speed control, programmability, auto changeover, backlight, locking keypad and a large LCD display.

5. Flat Stat Thermostat: The Flat Stat thermostat shall

incorporate 3-speed control, programmability, auto changeover, backlight, locking keypad and a large LCD display that is mounted flush to the wall. (Cooling only and heat/cool systems only.)

6. NP-Thermostat:

The NP-thermostat shall include 3-speed control, 5-1-1 (Monday through Friday - Saturday - Sunday) programmability, auto changeover, backlight, locking keypad and a large LCD display. (Cooling only and heat/cool systems only.)

