

40KMC / 38HDF
40KMQ / 38QRF
In-Ceiling Cassette Duct-Free Split System
Sizes 018 to 036



Turn to the Experts.™

Product Data



INDUSTRY LEADING FEATURES / BENEFITS

AN INEXPENSIVE AND CREATIVE SOLUTION TO DESIGN PROBLEMS.

The 38HDF(QRF) / 40KMC (KMQ) series duct-free split systems are a matched combination of an outdoor condensing unit and an indoor fan coil unit connected only by refrigerant tubing and wires.

The in-ceiling cassette fan coils are ideal for retrofit or modernization projects where a false ceiling is available. This selection of fan coils permits inexpensive and creative solutions to design problems such as:

- Add-ons to current space where the existing system cannot handle the load.
- Special space requirements, like a conference room, where the load varies.

These compact in-ceiling cassette units require less than 12 inches (304.8 mm) of false ceiling space and the only part that is seen is an aesthetically pleasing grille that blends with most decor.

The ideal compliment to your ducted system when it is impractical or prohibitively expensive to use ductwork.

LOW SOUND LEVELS

For applications like conference rooms or libraries where noise is a concern, the in-ceiling cassette is the answer. The indoor units are whisper quiet. There are no compressors indoors, either in the conditioned space or directly over it, and there is none of the noise usually generated by air being forced through ductwork.

When sound ordinances and proximity to neighbors demand quiet operation, the 38HDF/QRF unit is the right choice: The advanced, horizontal blow-through airflow design distributes air more evenly over the coil.

SECURE OPERATION

If security is an issue, outdoor and indoor units are connected only by refrigerant piping and wiring to prevent intruders from crawling through ductwork. In addition, since 38HDF/QRF units can be installed close to an outside wall, coils are protected from vandals and severe weather.

FAST INSTALLATION

The small footprint of the outdoor unit provides additional benefits. Because they require minimal service and airflow clearances, the outdoor units can be located virtually anywhere - on the ground, roof, balcony, under a deck, or even mounted on an outside wall.

The compact in-ceiling cassette requires less than 12 inches (304.8 mm) of false ceiling and the 40KMC018 unit fits into a 2' X 2' (0.6 m X 0.6 m) false ceiling.

These units are fast and easy to install ensuring minimal disruption to customers in the workplace and making them ideal for retrofit applications.

SIMPLE SERVICING AND MAINTENANCE

Saving time and money was a big consideration when designing these systems.

On the indoor unit, opening the grille will allow a service technician access to the control box and to remove the cleanable filters. There is even a plug to drain water from the condensate pan if it is ever required.

On the outdoor unit, a single panel provides immediate access to the isolated compressor and control compartment, allowing a service technician to check the unit operation without a loss of condenser airflow. In addition, the blow-through design of the outdoor section means that dirt accumulates on the inside surface of the coil. Coils can be cleaned from the outside using a pressure hose and detergent without removing grilles or using fin combs.

BUILT-IN RELIABILITY

Duct-free split system indoor and outdoor units are designed to provide years of trouble-free operation.

The in-ceiling cassette units include protection against freeze-up and high evaporator temperatures on heat pumps.

The condensing units and heat pumps are also protected. There is a 3-minute time delay before the compressor will re-start. An oversized accumulator, high and low pressure switches (or liquid line pressure switch on the heat pump), and compressor internal overload protection will ensure a reliable system that is ideal for light commercial applications.

INDIVIDUAL ROOM COMFORT

Maximum occupant comfort was key in the design of the in-ceiling cassette units.

For instance, the indoor unit is equipped with a motorized louver system that provides optimum air distribution into the conditioned room. The user can select eight different louver operating modes to adjust the airflow according to their specific needs.

The air can be distributed from four sides of the unit. This allows the unit to be installed in the center of the room. For applications where the unit has to be installed near a wall or in a corner, a special kit is available to close one or two outlets.

On heat pumps, the controls have built-in features to automatically compensate for air stratification and avoid cold blow on start-up or during defrost.

ECONOMICAL OPERATION

The duct-free split system design allows individual room heating or cooling when required. There is no need to run large supply-air fans or chilled water pumps to handle a few spaces with unique load patterns. In addition, because air is moved only in the space required, no energy is wasted moving air through ducts.

EASY-TO-USE CONTROLS

The in-ceiling cassette units have microprocessor-based controls to provided the ultimate in comfort and efficiency. Either a user friendly wireless remote control or a wired controller provides the interface between user and the unit.

FLEXIBILITY

A variety of accessories simplify the installation process and help meet system requirements and weather conditions. See table of available accessories on page 4.

AGENCY LISTINGS

All systems are listed with AHRI (Air Conditioning, Heating & Refrigeration Institute), and UL.

MODEL NUMBER NOMENCLATURE

INDOOR UNIT

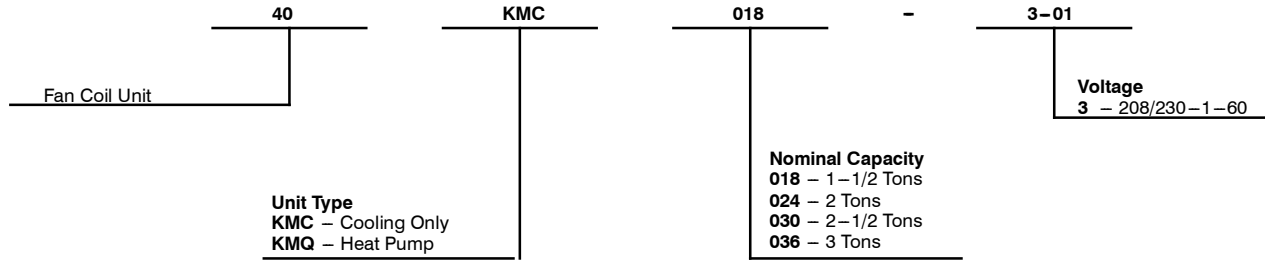

OUTDOOR UNIT

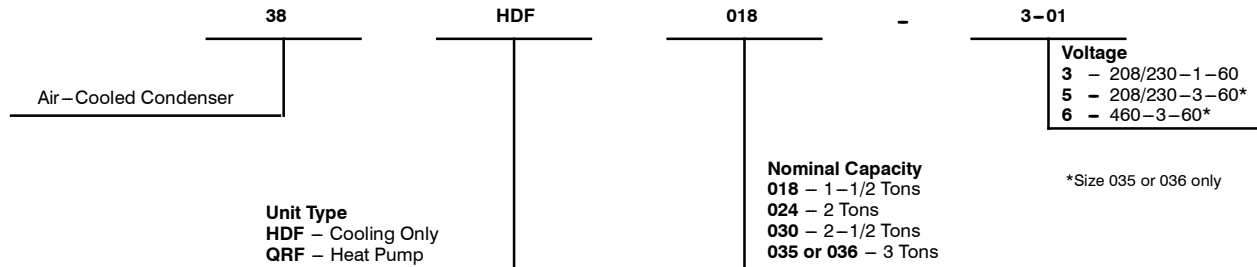

ARI Standard
210/240 UAC



ARI Standard
210/240 UHP



40KMC, KMQ / 38HDF, QRF

AHRI* CAPACITY RATINGS

System Type	Outdoor Section	Indoor Section	Standard CFM		Net Cooling BTUH	SEER	EER	High Heat	
			Outdoor	Indoor				BTUH	HSPF
Cooling	38HDF018---3	40KMC018---3	1720	470	17,000	13	10.9	N/A	N/A
	38HDF024---3	40KMC024---3	1720	690	23,600	13	11.5	N/A	N/A
	38HDF030---3	40KMC03036---3	1720	910	29,000	13	11.5	N/A	N/A
	38HDF036---3	40KMC03036---3	3900	910	36,400	13	11.0	N/A	N/A
	38HDF036---5	40KMC03036---3	3900	910	36,400	13	11.0	N/A	N/A
	38HDF036---6	40KMC03036---3	3900	910	36,400	13	11.0	N/A	N/A
Cooling with Electric Heat	38HDF018---3	40KMQ01824---3	1720	690	17,000	13	11.0	N/A	N/A
	38HDF024---3	40KMQ01824---3	1720	690	22,600	13	11.0	N/A	N/A
	38HDF030---3	40KMQ03036---3	1720	910	29,000	13	11.0	N/A	N/A
	38HDF036---3	40KMQ03036---3	3900	910	36,000	13	11.0	N/A	N/A
	38HDF036---5	40KMQ03036---3	3900	910	36,000	13	11.0	N/A	N/A
	38HDF036---6	40KMQ03036---3	3900	910	36,000	13	11.0	N/A	N/A
Heat Pump	38QRF018---3	40KMQ01824---3	1720	690	17,900	13	11.0	16,800	7.7
	38QRF024---3	40KMQ01824---3	1720	690	22,600	13	11.0	20,800	7.7
	38QRF030---3	40KMQ03036---3	3900	910	29,200	13	11.0	27,400	7.7
	38QRF035---3	40KMQ03036---3	3900	910	33,400	13	11.0	32,400	7.7
	38QRF035---5	40KMQ03036---3	3900	910	33,400	13	11.0	32,400	7.7
	38QRF035---6	40KMQ03036---3	3900	910	33,400	13	11.0	32,400	7.7

*Air Conditioning, Heating & Refrigeration Institute

Legend

HSPF – Heating Seasonal Performance Factor

SEER – Seasonal Energy Efficiency Ratio

NOTES:

- Ratings are net values reflecting the effects of circulating fan heat. Ratings are based on: Cooling Standard: 80°F (26.67°C) db, 67°F (19.44°C) wb air entering indoor unit and 95°F (35°C) db air entering outdoor unit. High Temperature Heating Standard: 70°F (21.11°C) db air entering indoor unit and 47°F (8.33°C) db, 43°F (6.11°C) wb air entering outdoor unit.
- Ratings are based on 25 ft. (7.62 m) of interconnecting refrigerant lines.
- All system ratings are based on fan coil units operating at high fan speed. Consult Physical Data tables for airflows at all available fan speeds.

STANDARD FEATURES AND ACCESSORIES

Ease Of Installation	
Indoor and Outdoor Compact Size	S
Outdoor Unit Wall Mounting Kit	A
Outdoor Unit Stacking Kit	A
Built-in Condensate Pump	S
Comfort Features	
Microprocessor Controls	S
Automatic Air Sweep	S
Air Direction Control	S
Auto Restart Function	S
Cold Blow Protection On Heat Pumps	S
Air Stratification Compensation	S
Emergency Run Mode	S
Auto Changeover on Heat Pumps	S
Energy Saving Features	
Sleep Mode	S
Stop/Start Timer	S
Safety And Reliability	
3 Minute Time Delay For Compressor	S
Over Current Protection For Compressor	S
Crankcase Heater (standard on 38QRF-030,035)	A
High and Low Pressure Switches on Cooling Only Units	S
High Pressure Switch and Loss of Charge Switch on Heat Pump	S
Indoor Coil Freeze Protection	S
Indoor Coil High Temperature Protection On Heat Pumps	S
Condenser High Temperature Protection On Heat Pumps	S
Accumulator On Cooling Only and Heat Pumps	S
Ease Of Service And Maintenance	
Control Box Accessible From Bottom of Unit	S
Cleanable Filters	S
Diagnostics	S
Test Mode	S
Liquid Line Pressure Taps	S
Suction And Discharge Pressure Taps	S
Application Flexibility	
208/230 and 460 3 Phase on Size 035 and 036	S
Long Lines up to 200 feet (61 m) (accessories required)	A
Power Ventilation Kit	A
Low Ambient Controls (-20° F / -28.9° C)	A
Knock-out to run a duct from an adjacent room	A
Wind Baffles	A
Wired or Wireless Controls	A
Zone Manager	A
Warranty	
5 - Year Compressor Warranty	S
1 - Year Parts Warranty	S
Compressor Extended Warranty Years 6 Thru 10	O
All Parts And Labor Years 2 Thru 5	O
All Parts And Labor Years 2 Thru 5, Compressor Years 6 Thru 10	O

Legend

- S Standard
- A Accessory
- O Optional

INDOOR UNIT ACCESSORIES

Grille

To maximize shipping efficiency, the grille for the in-ceiling cassette is set up as an accessory.

Air Supply Outlet Obstruction Kit

This kit can be used when up to two discharge outlets need to be blocked in applications where the unit is installed close to a wall or a corner.

Power Ventilation Kit

This kit will allow up to 20% of outside air to be introduced into the conditioned space.

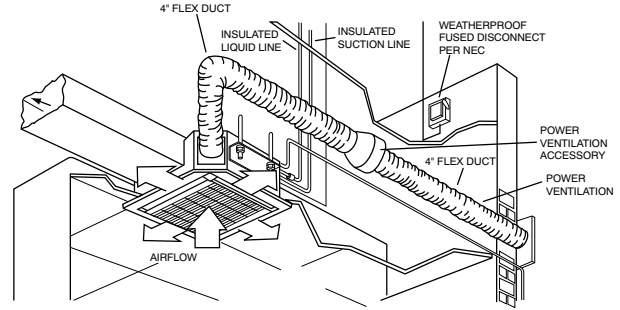

A07268

Fig. 1 – Power Ventilation Kit

Remote Control (33MC-UMC)

To provide added flexibility of choosing the user interface method with the unit, a remote control or wired controller can be ordered.

Remote Control Locking Mount Kit

This kit can be used where there is a concern that the remote control can be misplaced. This accessory locks the remote in place.

Wired Controller (33MC-URC)

For applications where the use of a wireless remote control is not desired, the 40KMC/KMQ units can be controlled by means of a wired, wall-mounted control with an LCD display.

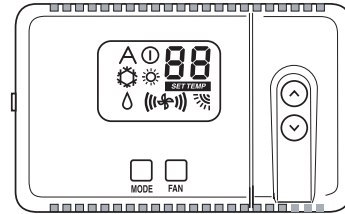

A08432

Fig. 2 – Wall Mounted Control with LCD Display

Room Control Wiring Kit (33MC9005)

Up to six units can be daisy-chained together and controlled by one wired remote controller. A room control wiring kit is required for each slave unit.

Zone Manager (33MC-UZM)

For applications where more sophisticated controls are required, a Zone Manager that permits the connection of up to 32 different indoor units, divided into a maximum of eight different zones, can be used. Zone Manager Wiring Kit (33MC9004) is required to connect different units to the zone manager.

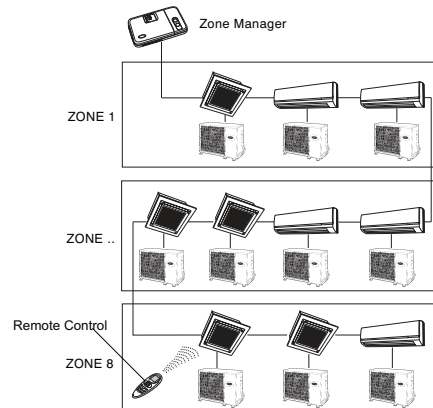

A08443

Fig. 3 – Zone Manager Connection

OUTDOOR UNIT ACCESSORIES

Low Ambient Kit

The kit controls condenser fan cycling using a pressure switch. It is specifically designed to cycle the outdoor fan-motor in response to saturated condensing pressure. This device maintains a constant saturated condensing temperature of $100\text{ }^{\circ}\text{F} \pm 10\text{ }^{\circ}\text{F}$ ($37.78\text{ }^{\circ}\text{C} \pm 5.6\text{ }^{\circ}\text{C}$) at outdoor-air temperatures between $55\text{ }^{\circ}\text{F}$ and $-20\text{ }^{\circ}\text{F}$ ($12.78\text{ }^{\circ}\text{C} \pm -12.22\text{ }^{\circ}\text{C}$), and can be used on all outdoor units without changing the outdoor fan motor.

Winter Start Control

The Winter Start Control is a SPST delay relay. The control bypasses the low pressure switch for approximately 3 minutes to permit start-up for cooling operation under low load conditions at low ambient temperatures. This relay is recommended on cooling only systems that have the accessory Low Ambient Kit.

Isolation Relay

The Isolation Relay must be used when Low Ambient Kit is used with heat pumps to ensure the pressure switch is bypassed when unit is running in heat pump mode.

Liquid Line Solenoid Valve

The Liquid Line Solenoid Valve is an electrically operated shut-off valve that is installed at the outdoor unit to stop and start refrigerant flow in response to compressor operation. The valve maintains a column of refrigerant in the liquid line between compressor operating cycles and is required for certain long line applications and to improve system performance.

Crankcase Heater

The Crankcase Heater is available for units with scroll compressors and clamps onto the compressor oil sump. It is recommended for low ambient applications. The Crankcase Heater is standard on 38QRF030.

Wind Baffles

The Wind Baffle is a sheet metal shield used to provide improved unit operation during high winds and is recommended whenever the low ambient accessory is used.

Stacking Kit

Stacking Kits allow stacking of equally sized units or permit smaller units to be stacked on top of larger units.

NOTE: THIS KIT CANNOT BE USED WITH HEAT PUMPS.

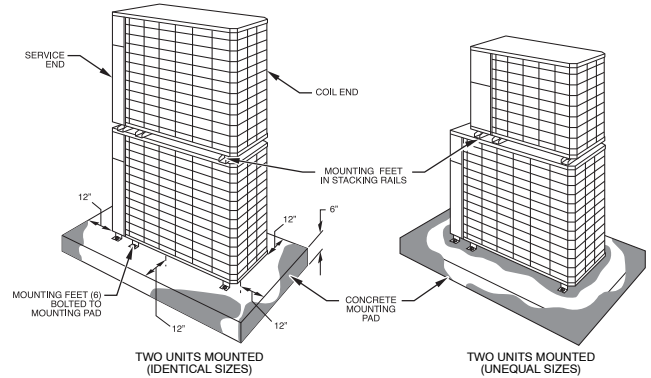

A06417

Fig. 4 – Stacking Kit

Wall Mounting Kit

Wall mount brackets are mounted on the outside of the structure to raise the unit from ground level, or to mount the unit on a wall adjacent to a sloping roof. Wall mounts are also useful in areas of heavy snowfall or where space is at a premium.

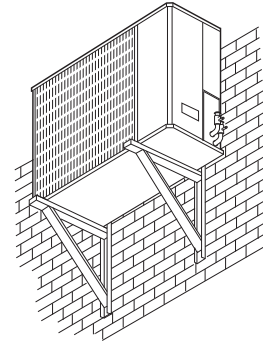

NOTE: Unit must be at least 6 in. (152.4 mm) from wall.

D06006

Fig. 5 – Wall Mounting Kit

DIMENSIONS - OUTDOOR

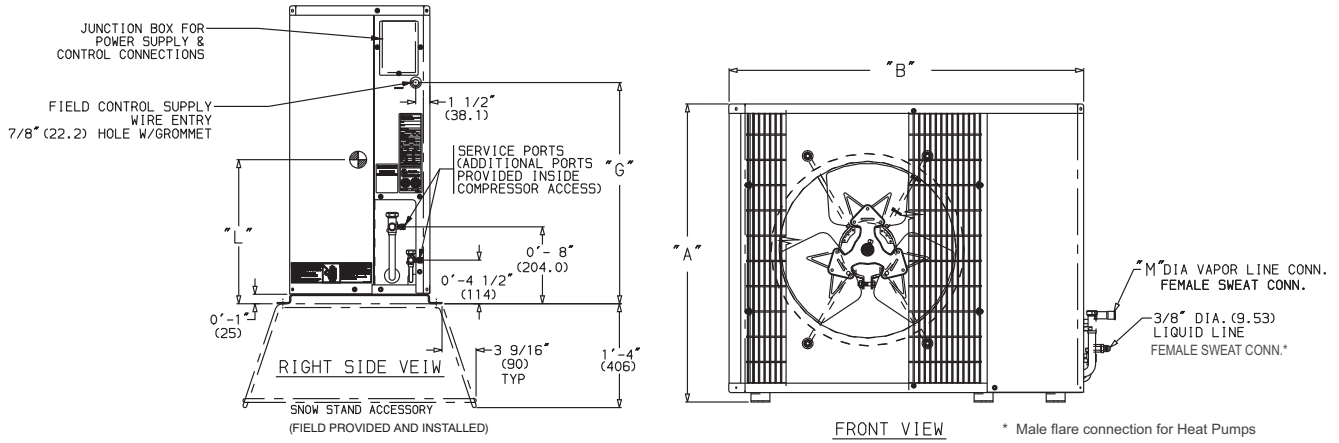

40KMC, KMQ / 38HDF, QRF

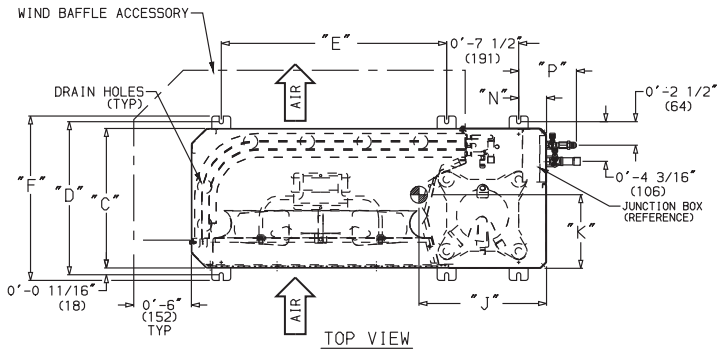

UNIT SIZE	M		OPERATING WT		
	in.	mm	lb	kg	
38HDF	018	5/8	15.88	166	75.3
	024	5/8	15.88	176	79.8
	030	3/4	19.05	187	84.8
	036	3/4	19.05	250	113.4
38QRF	018	5/8	15.88	166	75.3
	024	5/8	15.88	176	79.8
	030	3/4	19.05	187	84.8
	035	3/4	19.05	221	105.2

UNIT MODELS		CHASSIS SIZE (Reference)	A	B	C	D	E	F	G	H	J	K	L	N	P
38HDF Unit Size	38QRF Unit Size														
018	018	0	2'-11/8" (638.2)	3'-015/16" (938.2)	1'-29/16" (369.9)	1'-4" (406.4)	1'-117/16" (595.3)	1'-53/16" (436.6)	1'-51/8" (435)	1'-10" (559.1)	1'-1" (330.2)	0'-65/8" (168.3)	0'-111/4" (285.8)	0'-215/16" (75)	0'-6" (152.4)
024,030	024	0.6	2'-71/8" (790.6)	3'-015/16" (938.2)	1'-29/16" (369.9)	1'-4" (406.4)	1'-117/16" (595.3)	1'-53/16" (436.6)	1'-111/8" (587.4)	2'-4" (711.5)	1'-2" (355.6)	0'-63/4" (171.5)	0'-115/8" (295.3)	0'-215/16" (75)	0'-6" (152.4)
036	030,035	1.0	3'-19/16" (944.6)	3'-89/16" (1131.9)	1'-51/16" (433.4)	1'-67/16" (468.3)	2'-61/2" (774.7)	1'-75/8" (498.5)	2'-59/16" (741)	2'-101/16" (865.5)	1'-111/16" (347.7)	0'-81/8" (206.4)	1'-37/8" (403.2)	0'-37/16" (88)	0'-61/2" (165.4)

NOTE: Dimensions shown in feet-inches. Dimensions in () are millimeters.

Fig. 6 – Outdoor Unit Dimensions

A08446

CLEARANCES - OUTDOOR

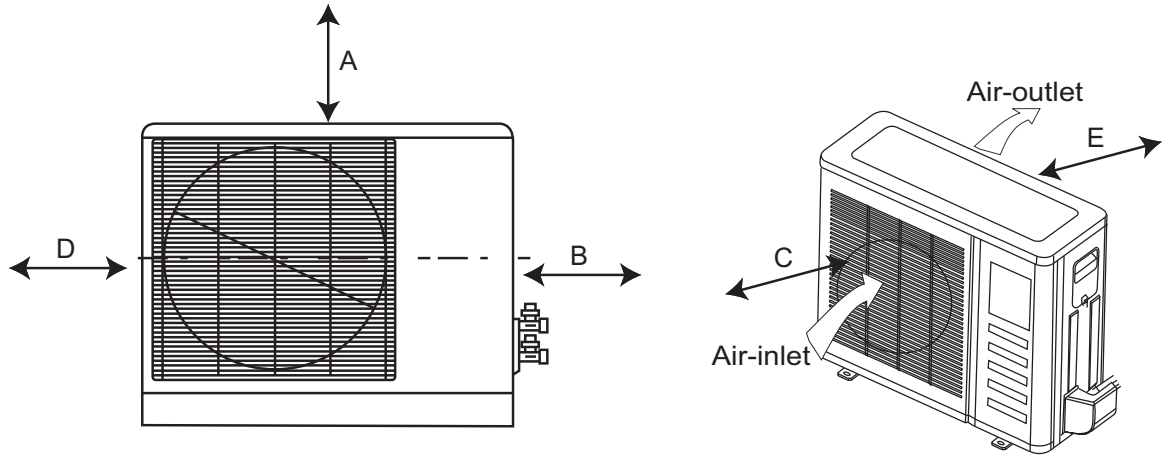

UNIT	Coil Facing Wall – in. (mm)	Fan Facing Wall – in. (mm)
A	24 (610)	24 (610)
B	36 (914)	36 (914)
C	36 (914)	8 (203)
D	6 (152)	8 (203)
E	6 (152)	36 (914)

Fig. 7 – Outdoor Unit Clearance

A08436

INDOOR UNIT DIMENSIONS

40KMC018

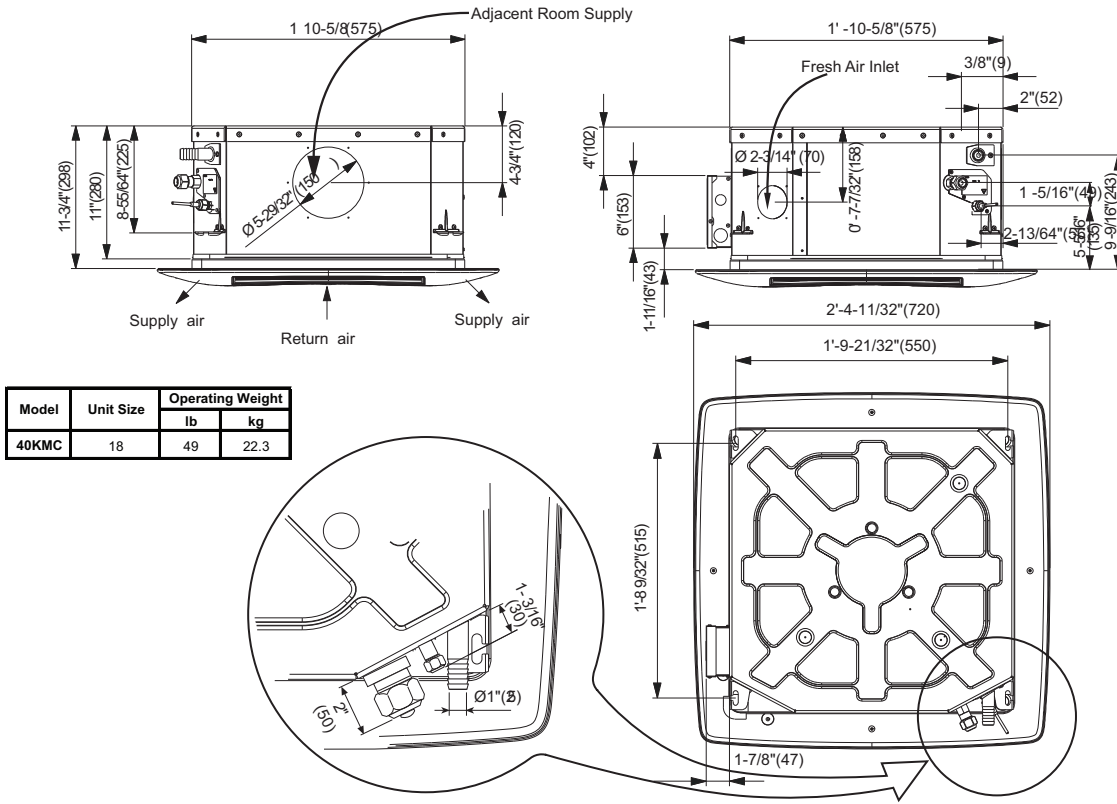

40KMC024-036 / 40KMQ018-036

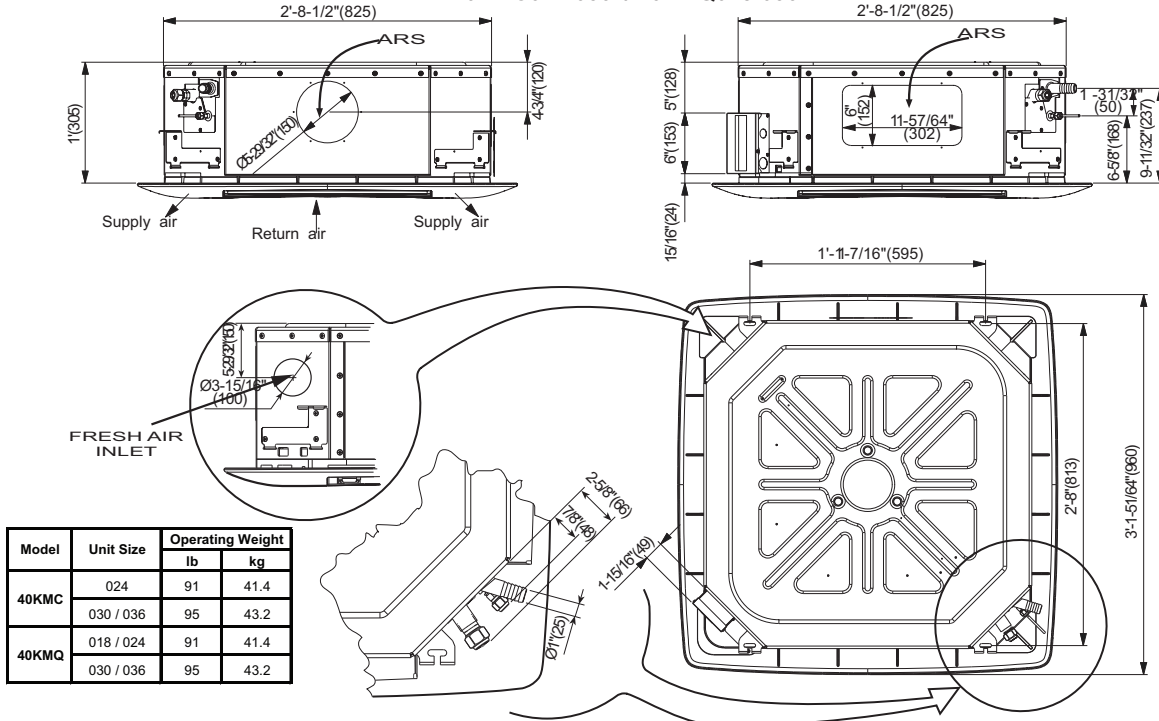

NOTE: Dimensions in () are in mm.

Fig. 8 – 40KMC, KMQ Indoor Unit Clearance

40KMC, KMQ / 38HDFQRF

PHYSICAL DATA - OUTDOOR UNIT 38HDF

Outdoor Unit 38HDF	018	024	030	036	036	036
System Voltage	208/230-1-60	208/230-1-60	208/230-1-60	208/230-1-60	208/230-3-60	460-3-60
Nominal Capacity (Btuh)	18000	24000	30000	36000	36000	36000
Operating Weight lb (kg)	166 (75.3)	176 (79.8)	187 (84.8)	250 (113.4)	250 (113.4)	250 (113.4)
Refrigerant Type	R-410A					
Metering Device	Accurator at Outdoor Unit					
Piston Size Required	49	57	61	74	74	74
Unit Factory Charge lb (kg)	4.8(2.2)	5.3(2.4)	5.0 (2.3)	8.5(3.9)	8.5(3.9)	8.5(3.9)
System Charge (25 ft line) lb (kg)	4.8(2.2)	6.5 (2.95)	8.0 (3.6)	9.3 (4.2)	9.3 (4.2)	9.3 (4.2)
Additional Charge lb (kg)	0.0	1.2 (.55)	3.0 (1.4)	.8 (.36)	.8 (.36)	.8 (.36)
Compressor						
Type	Scroll					
Model	ZP16K5E-PFV	ZP21K5E-PFV	ZP25K5E-PFV	ZP34K5E-PFV	ZP34KE-TF5	ZP34KE-TFD
Oil Charge (POE -oz)	25	25	25	42	42	42
Outdoor Fan						
Rpm/CFM	840/1720	840/1720	840/1720	850/1720	850/1720	850/1720
Diameter (in) .. No. of Blades	18...3	18...3	18...3	24...3	24...3	24...3
Motor HP	1/8	1/8	1/8	1/4	1/4	1/4
Outdoor Coil						
Face Area (sq. ft)	5.82	7.27	7.27	12.1	12.1	12.1
No. Rows	2	3	3	2	2	2
Fins per inch	20	20	20	20	20	20
Circuits	2	3	3	6	6	6
High Pressure Switch						
Cut-In (psig)	420±25					
Cut-Out (psig)	650±10					
Low Pressure Switch						
Cut-In (psig)	45±25					
Cut-Out (psig)	20±5					
Fusible Plug ° F (° C)	210 (99)					
Refrigerant Lines						
Connection Type	Mixed Phase/Suction – Sweat					
Suction/Vapor (in) OD	5/8			3/4		
Mixed Phase * (in) OD	3/8					
Maximum Length** ft (m)	200 (61)					
Max Lift (Fan Coil Above) ft (m)	65 (20)					
Max Drop (Fan Coil Below) ft (m)	200 (61)					
Controls						
Control Voltage	24 vac					
External Finish	Gray					

* Mixed phase line needs to be insulated

** Long Line accessories required beyond 80 ft (24.4 m). Refer to *Duct-Free Split System Long Line Guide* for additional information.

40KMC, KMQ / 38HDF, QRF

PHYSICAL DATA (CONT.) - OUTDOOR UNIT 38QRF

Outdoor Unit 38QRF	018	024	030	035	035	035
System Voltage	208/230-1-60	208/230-1-60	208/230-1-60	208/230-1-60	208/230-3-60	460-3-60
Nominal Capacity (Btuh)	18000	24000	30000	36000	36000	36000
Operating Weight lb(kg)	166 (75.3)	176 (79.8)	187 (84.8)	221 (100.5)	221 (100.5)	221 (100.5)
Refrigerant Type	R-410A					
Unit Factory Charge lb (kg)	5.5 (2.5)	6.8 (3.1)	10.7 (4.9)	10.5 (4.8)	10.5 (4.8)	10.5 (4.8)
System Charge (25 ft line) lb (kg)	5.5 (2.5)	6.8 (3.1)	12.5 (5.7)	10.5 (4.8)	10.5 (4.8)	10.5 (4.8)
Additional Charge lb (kg)	0.0	0.0	1.8 (.82)	0.0	0.0	0.0
Metering Device	Accurator at Outdoor Unit					
Cooling Piston	51	55	63	70	70	70
Heating Piston	46	53	55	63	63	63
Compressor	Scroll					
Type	Scroll					
Model	ZP16K5E-PFV	ZP21K5E-PFV	ZP25K5E-PFV	ZP31K5E-PFV	ZP31K5E-TF5	ZP31K5E-TFD
Oil Charge (POE -oz)	25	25	25	42	42	42
Crankcase Heater (watts)	NA			40		
Outdoor Fan						
Rpm/CFM	840/1720	840/1720	850/3900	850/3900	850/3900	850/3900
Diameter (in) .. No. of Blades	18...3	18...3	24...3	24...3	24...3	24...3
Motor HP	1/8	1/8	1/4	1/4	1/4	1/4
Outdoor Coil						
Face Area (sq. ft)	5.82	7.27	12.1	12.1	12.1	12.1
No. Rows	2	3	2	2	2	2
Fins per inch	20	20	20	20	20	20
Circuits	3	3	6	6	6	6
High Pressure Switch						
Cut-In (psig)	420±25					
Cut-Out (psig)	650±10					
Low Pressure Switch						
Cut-In (psig)	45±25					
Cut-Out (psig)	20±5					
Fusible Plug °F (°C)	210 (99)					
Refrigerant Lines						
Connection Type	Mixed Phase – Flare/Suction – Sweat					
Suction/Vapor (in) OD	5/8			3/4		
Mixed Phase * (in) OD	3/8					
Maximum Length** ft (m)	200 (61)					
Max Lift (Fan Coil Above) ft (m)	65 (20)					
Max Drop (Fan Coil Below) ft (m)	200 (61)					
Controls						
Control Voltage	24 vac					
External Finish	Gray					

* Mixed phase line needs to be insulated

** Long Line accessories required beyond 80 ft (24.4 m). Refer to *Duct-Free Split System Long Line Guide* for additional information.

40KMC, KMQ / 38HDF, QRF

PHYSICAL DATA (CONT.) - INDOOR UNIT 40KMC

Indoor Unit 40KMC	018	024	030	036
System Voltage	208/230-1-60	208/230-1-60	208/230-1-60	
Operating Weight lb(kg)	49 (22.3)	91 (41.4)	95 (43.2)	95 (43.2)
Refrigerant Type	R-410A			
Metering Device	Accurator At Outdoor Unit			
Moisture Removal Rate (Pints/hr)8	5.5	7.2	7.9	12.8
Indoor Fan				
Rpm/Cfm (High)	1000/470	440/690	660/910	660/910
Rpm/Cfm (Medium)	890/420	360/560	550/760	550/760
Rpm/Cfm (Low)	730/340	300/470	470/670	470/670
Motor Watts	120	110	210	210
Blower Quantity...Diameter (in)	1...11.1	1...18	1...18	1...18
Indoor Coil				
Face Area (sq. ft)	3.2	4.8	4.6	4.6
No. Rows	2	2	3	3
Fins per inch	22	18	18	18
Circuits	5	6	10	10
Filters				
Quantity...Size (in)	1...17 x 16	1...24 x 23 5/16		
Controls				
Remote Controller Options	Integrated Microprocessor Wireless (optional) , Wired (optional), Zone Control (optional)			
Fan Mode	High/Medium/Low/Auto			
Dehumidification Mode	Yes			
Sleep Mode	Yes			
Diagnostics	Yes			
Timer Mode	Yes			
Freeze Protection	Yes			
Test Mode	Yes			
Auto Restart	Yes			
Air Sweep	Yes			
Control Voltage	24vac			
Refrigerant Lines				
Connection Type	Flare			
Mixed Phase Line (in) OD	3/8			
Vapor Line (in) OD	5/8	3/4		
Condensate Drain				
Size (in)	1			
External Finish	White			

LEGEND

OD – Outside Diameter

40KMC, KMQ / 38HDF, QRF

PHYSICAL DATA (CONT.) - INDOOR UNIT 40KMQ

Indoor Unit 40KMQ	018	024	030	036
System Voltage	208/230-1-60			
Electric Heat KW	3.0			
Operating Weight lb(kg)	91 (41.4)	91 (41.4)	95 (43.2)	95 (43.2)
Refrigerant Type	R-410A			
Metering Device	Accurator At Outdoor Unit			
Moisture Removal Rate (Pints/hr)	3.7	6.2	8.8	10.2
Indoor Fan				
Rpm/Cfm (High)	440/690	440/690	660/910	660/910
Rpm/Cfm (Medium)	360/560	360/560	550/760	550/760
Rpm/Cfm (Low)	300/470	300/470	470/670	470/670
Motor Watts	110	110	210	210
Blower Quantity...Size (in)	1...18			
Indoor Coil				
Face Area (sq. ft)	4.8		4.6	
No. Rows	2		3	
Fins per inch	18		18	
Circuits	6		10	
Filters				
Quantity...Size (in)	1...24 x 23 5/16			
Controls				
Integrated Microprocessor				
Remote Controller Options	Wireless (optional) , Wired (optional), Zone Control (optional)			
Diagnostics	Yes			
Defrost Method	Demand Defrost			
Fan Mode	High/Medium/Low/Auto			
Dehumidification Mode	Yes			
Warm Start Feature	Yes			
Room Stratification Compensation				
Sleep Mode	Yes			
Timer Mode	Yes			
Freeze Protection	Yes			
Test Mode	Yes			
Auto Restart	Yes			
Air Sweep	Yes			
Control Voltage	24vac			
Refrigerant Lines				
Connection Type	Flare			
Mixed Phase Line (in) OD	3/8			
Vapor Line (in) OD	5/8		3/4	
Condensate Drain				
Size (in)	1			
External Finish	White			

LEGEND

OD – Outside Diameter

40KMC, KMQ / 38HDF, QRF

PERFORMANCE DATA

COOLING CAPACITIES COOLING ONLY 38HDF018 WITH 40KMC018

Temp °F (°C) Air Entering Condenser (Edb)	Air Entering Evaporator – Cfm/BF												
	330 / 0.04				400 / 0.04				450 / 0.04				
	Air Entering Evaporator – Ewb °F (°C)												
	57 (13.9)	62 (16.7)	67 (19.4)	72 (22.2)	57 (13.9)	62 (16.7)	67 (19.4)	72 (22.2)	57 (13.9)	62 (16.7)	67 (19.4)	72 (22.2)	
55 (12.8)	TCG	16.1	17.3	18.2	19.4	17.0	17.9	19.3	20.3	17.6	18.5	19.7	20.8
	SHG	14.5	12.9	11.0	9.5	15.4	13.7	11.8	10.1	15.7	14.3	12.5	10.5
	TC	15.8	17.0	17.9	19.1	16.7	17.6	19.0	20.0	17.2	18.1	19.3	20.4
	kW	1.00	1.00	1.00	1.00	1.00	1.00	1.01	1.00	1.00	1.01	1.00	1.00
	CMP	0.79	0.79	0.79	0.79	0.77	0.77	0.78	0.76	0.75	0.75	0.74	0.75
	LDB	40.4	45.3	50.9	55.3	45.4	49.8	54.4	58.6	48.9	52.1	56.0	60.3
LWB	36.6	42.2	48.5	54.4	39.7	45.7	51.2	57.3	41.4	47.3	53.0	58.9	
65 (18.3)	TCG	15.6	17.0	18.0	19.4	16.8	17.8	19.1	20.3	16.8	18.1	19.6	20.8
	SHG	14.3	12.9	10.9	9.4	15.7	13.9	11.8	10.0	16.8	14.3	12.4	10.4
	TC	15.3	16.7	17.8	19.1	16.4	17.4	18.7	19.9	16.4	17.7	19.2	20.4
	kW	1.11	1.12	1.13	1.12	1.12	1.12	1.13	1.12	1.12	1.13	1.13	1.12
	CMP	0.90	0.91	0.92	0.91	0.89	0.89	0.89	0.89	0.86	0.87	0.87	0.87
	LDB	40.9	45.2	51.2	55.7	44.9	49.3	54.3	58.8	46.6	52.0	56.2	60.5
LWB	37.4	42.7	48.7	54.5	40.0	45.8	51.5	57.4	42.2	47.6	53.1	58.9	
75 (23.9)	TCG	15.1	16.5	17.6	19.1	15.8	17.3	18.6	20.0	16.5	17.8	19.1	20.5
	SHG	14.0	12.8	10.8	9.2	15.8	13.9	11.8	9.9	16.5	14.6	12.3	10.3
	TC	14.8	16.2	17.4	18.9	15.4	17.0	18.3	19.6	16.1	17.4	18.7	20.0
	kW	1.24	1.25	1.26	1.26	1.25	1.26	1.26	1.26	1.25	1.26	1.26	1.25
	CMP	1.03	1.04	1.05	1.05	1.01	1.02	1.02	1.02	1.00	1.00	1.00	1.00
	LDB	41.8	45.5	51.4	56.1	44.6	49.3	54.4	58.9	47.3	51.3	56.3	60.6
LWB	38.2	43.4	49.2	54.8	41.2	46.3	51.9	57.6	42.6	47.9	53.5	59.1	
85 (29.4)	TCG	14.1	15.7	17.2	18.6	15.3	16.6	18.0	19.4	16.0	17.1	18.5	19.9
	SHG	14.0	12.5	10.8	9.0	15.3	13.8	11.6	9.7	16.0	14.5	12.2	10.1
	TC	13.9	15.5	16.9	18.3	14.9	16.3	17.6	19.1	15.6	16.7	18.0	19.5
	kW	1.38	1.40	1.40	1.41	1.39	1.40	1.40	1.40	1.40	1.40	1.40	1.41
	CMP	1.17	1.19	1.19	1.20	1.15	1.17	1.17	1.17	1.14	1.15	1.15	1.15
	LDB	41.7	46.3	51.5	56.6	45.8	49.5	54.8	59.4	48.3	51.5	56.5	61.0
LWB	39.6	44.3	49.7	55.4	41.8	47.0	52.5	58.1	43.1	48.5	54.0	59.6	
95 (35.0)	TCG	13.4	14.8	16.4	17.9	14.6	15.7	17.1	18.7	15.3	16.3	17.4	19.1
	SHG	13.4	12.1	10.5	8.8	14.6	13.4	11.3	9.5	15.3	14.2	11.8	9.8
	TC	13.1	14.6	16.1	17.6	14.2	15.4	16.8	18.3	14.9	15.9	17.0	18.7
	kW	1.53	1.55	1.56	1.57	1.54	1.56	1.57	1.57	1.55	1.56	1.56	1.57
	CMP	1.32	1.34	1.35	1.36	1.31	1.32	1.33	1.33	1.30	1.31	1.31	1.31
	LDB	43.5	47.4	52.1	57.2	47.3	50.3	55.4	59.9	49.7	52.0	57.0	61.6
LWB	40.6	45.5	50.6	56.1	42.6	48.0	53.3	58.7	43.7	49.3	54.7	60.1	
105 (40.6)	TCG	12.6	13.8	15.5	16.9	13.8	14.7	16.2	17.7	14.5	15.5	16.7	18.1
	SHG	12.6	11.6	10.1	8.4	13.8	12.9	11.0	9.1	14.5	13.2	11.7	9.5
	TC	12.4	13.5	15.2	16.7	13.5	14.3	15.9	17.4	14.1	15.1	16.3	17.7
	kW	1.69	1.71	1.74	1.74	1.71	1.72	1.74	1.74	1.72	1.73	1.74	1.74
	CMP	1.48	1.50	1.53	1.53	1.47	1.49	1.51	1.51	1.46	1.48	1.49	1.49
	LDB	45.6	48.8	53.1	58.2	49.1	51.5	56.0	60.8	51.3	54.1	57.5	62.3
LWB	41.7	46.9	51.7	57.1	43.5	49.1	54.2	59.5	44.5	50.0	55.4	60.8	
115 (46.1)	TCG	11.8	12.6	14.3	15.9	12.9	13.7	15.1	16.7	13.6	14.2	15.5	17.1
	SHG	11.8	11.0	9.6	8.0	12.9	11.9	10.7	8.7	13.6	12.8	11.3	9.1
	TC	11.5	12.4	14.1	15.6	12.6	13.4	14.8	16.3	13.2	13.7	15.1	16.7
	kW	1.87	1.88	1.91	1.93	1.88	1.89	1.93	1.93	1.90	1.91	1.93	1.93
	CMP	1.66	1.67	1.70	1.72	1.65	1.66	1.69	1.70	1.64	1.65	1.67	1.68
	LDB	48.0	50.4	54.5	59.3	51.2	53.7	56.8	61.6	53.1	55.0	58.3	62.9
LWB	42.9	48.4	53.1	58.2	44.5	50.1	55.2	60.4	45.4	51.2	56.4	61.6	
125 (51.7)	TCG	10.9	11.6	13.0	14.7	11.9	12.0	13.7	15.3	12.6	12.6	14.2	15.7
	SHG	10.9	10.1	9.1	7.6	11.9	11.8	10.1	8.2	12.6	12.6	10.8	8.6
	TC	10.6	11.4	12.8	14.5	11.6	11.7	13.4	15.0	12.2	12.2	13.7	15.3
	kW	2.06	2.06	2.10	2.13	2.07	2.07	2.12	2.13	2.09	2.09	2.13	2.13
	CMP	1.85	1.85	1.89	1.92	1.84	1.84	1.88	1.90	1.83	1.83	1.87	1.88
	LDB	50.5	52.9	55.9	60.4	53.5	54.0	58.0	62.7	55.2	55.3	59.2	63.9
LWB	44.1	49.6	54.5	59.4	45.6	51.7	56.4	61.4	46.4	52.3	57.4	62.5	

Rating condition

Not recommended for long-term operation.

LEGEND

BF – Bypass Factor
 CMP – Compressor
 Edb – Entering Dry Bulb
 Ewb – Entering Wet Bulb
 kW – Total Power
 LDB – Leaving Dry Bulb
 LWB – Leaving Wet Bulb
 SHG – Gross Sensible Capacity (1000 Btu/hour)
 TC – Total Net Cooling Capacity (1000 Btu/hour)
 TCG – Gross Cooling Capacity (1000 Btu/hour)

NOTES:

- Direct interpolation is permissible. Do not extrapolate.
- The SHG is based on 80°F (26.67°C) edb temperature of air entering indoor coil.
 Below 80°F (26.67°C) edb, subtract (corr factor x cfm) from SHG.
 Above 80°F (26.67°C) edb, add (corr factor x cfm) to SHG.
 Correction Factor = 1.10 x (1 – BF) x (edb – 80).

PERFORMANCE DATA (CONT.)

COOLING CAPACITIES COOLING ONLY 38HDF024 WITH 40KMC024

Temp ° F (° C) Air Entering Condenser (Edb)		Air Entering Evaporator – Cfm/BF											
		445 / 0.05				530 / 0.05				680 / 0.05			
		Air Entering Evaporator – Ewb ° F (° C)											
		57 (13.9)	62 (16.7)	67 (19.4)	72 (22.2)	57 (13.9)	62 (16.7)	67 (19.4)	72 (22.2)	57 (13.9)	62 (16.7)	67 (19.4)	72 (22.2)
55 (12.8)	TCG	21.7	23.5	25.0	27.3	22.9	24.5	26.7	28.2	24.7	26.6	28.4	29.2
	SHG	20.1	17.8	15.5	13.7	21.3	18.8	16.7	14.4	23.9	21.5	18.4	15.2
	TC	21.5	23.2	24.8	27.1	22.6	24.1	26.4	27.9	24.3	26.2	28.0	28.8
	kW	1.22	1.23	1.23	1.24	1.23	1.23	1.23	1.21	1.22	1.24	1.24	1.21
	CMP	1.01	1.02	1.02	1.03	1.00	1.00	1.00	0.98	0.96	0.98	0.98	0.95
	LDB	39.2	44.2	49.3	53.5	43.7	48.4	52.2	56.6	48.3	51.8	56.4	60.8
65 (18.3)	LWB	36.5	42.0	47.9	53.4	39.3	45.0	50.3	56.3	42.6	48.0	53.6	59.9
	TCG	20.9	22.8	24.7	26.4	22.3	24.1	25.8	28.2	23.7	25.4	27.8	29.2
	SHG	19.6	17.6	15.5	13.0	21.1	19.2	16.2	14.3	23.7	21.0	18.1	14.7
	TC	20.6	22.6	24.5	26.1	22.0	23.8	25.4	27.9	23.3	25.0	27.4	28.7
	kW	1.36	1.38	1.40	1.41	1.38	1.39	1.40	1.40	1.39	1.40	1.41	1.41
	CMP	1.15	1.17	1.19	1.20	1.15	1.16	1.17	1.17	1.13	1.14	1.15	1.15
75 (23.9)	LDB	40.2	44.6	49.4	54.7	44.1	47.7	53.1	56.8	48.6	52.6	56.6	61.5
	LWB	37.4	42.6	48.2	54.2	39.8	45.2	51.0	56.3	43.2	48.7	54.0	59.9
	TCG	20.1	22.0	24.1	25.9	21.7	23.3	25.1	27.5	23.0	24.7	26.8	28.6
	SHG	19.1	17.4	15.3	12.9	20.5	19.0	16.1	13.7	23.0	21.1	17.9	14.7
	TC	19.9	21.8	23.8	25.6	21.4	23.0	24.8	27.2	22.6	24.3	26.4	28.2
	kW	1.53	1.55	1.57	1.58	1.54	1.56	1.57	1.58	1.56	1.57	1.58	1.58
85 (29.4)	CMP	1.32	1.34	1.36	1.37	1.31	1.33	1.34	1.35	1.30	1.31	1.32	1.32
	LDB	41.2	45.1	49.8	55.0	45.1	48.1	53.4	57.7	49.5	52.4	57.0	61.6
	LWB	38.3	43.4	48.8	54.6	40.4	45.9	51.5	56.8	43.7	49.1	54.5	60.2
	TCG	19.4	21.2	23.2	25.0	20.5	22.3	24.2	26.7	22.4	23.8	25.8	27.8
	SHG	18.6	17.0	14.9	12.5	20.5	18.6	15.8	13.4	22.4	20.9	17.6	14.5
	TC	19.1	20.9	23.0	24.8	20.1	22.0	23.9	26.4	21.9	23.3	25.4	27.3
95 (35.0)	kW	1.71	1.73	1.76	1.76	1.72	1.75	1.76	1.77	1.75	1.76	1.77	1.78
	CMP	1.50	1.52	1.55	1.55	1.49	1.52	1.53	1.54	1.49	1.50	1.51	1.52
	LDB	42.3	45.9	50.6	55.7	45.2	48.7	53.7	58.2	50.4	52.6	57.3	61.8
	LWB	39.1	44.3	49.6	55.3	41.5	46.7	52.2	57.4	44.1	49.7	55.0	60.6
	TCG	18.3	20.2	22.2	24.1	19.7	21.3	23.1	25.6	21.5	22.7	24.0	26.6
	SHG	18.3	16.5	14.4	12.1	19.7	18.2	15.4	13.0	21.5	20.7	16.7	14.1
105 (40.6)	TC	18.0	19.9	22.0	23.8	19.4	21.0	22.8	25.3	21.1	22.3	23.6	26.1
	kW	1.90	1.93	1.96	1.97	1.92	1.94	1.97	1.97	1.95	1.96	2.05	2.06
	CMP	1.69	1.72	1.75	1.76	1.69	1.71	1.74	1.74	1.69	1.70	1.79	1.80
	LDB	42.8	46.8	51.5	56.5	46.5	49.3	54.6	58.9	51.6	52.9	58.0	62.3
	LWB	40.3	45.3	50.4	56.0	42.2	47.5	52.9	58.1	44.7	50.3	55.7	61.1
	TCG	17.5	19.1	21.1	23.0	18.8	20.1	22.0	24.3	20.6	21.4	23.2	25.3
115 (46.1)	SHG	17.5	16.0	13.9	11.7	18.8	17.7	15.0	12.5	20.6	20.0	16.5	13.6
	TC	17.2	18.9	20.9	22.8	18.5	19.8	21.7	24.0	20.2	21.0	22.8	24.8
	kW	2.11	2.14	2.18	2.19	2.13	2.15	2.19	2.19	2.16	2.18	2.19	2.20
	CMP	1.90	1.93	1.97	1.98	1.90	1.92	1.96	1.96	1.90	1.92	1.93	1.94
	LDB	44.5	47.8	52.5	57.4	48.1	50.2	55.2	59.8	52.8	53.8	58.8	62.9
	LWB	41.1	46.3	51.4	56.9	42.9	48.5	53.7	58.9	45.3	51.0	56.4	61.7
125 (51.7)	TCG	16.6	17.8	19.9	21.8	17.8	18.7	20.7	22.9	19.5	20.3	21.7	23.8
	SHG	16.6	15.5	13.3	11.1	17.8	17.1	14.5	11.9	19.5	19.0	16.1	12.9
	TC	16.3	17.6	19.6	21.5	17.5	18.4	20.4	22.5	19.1	19.8	21.2	23.3
	kW	2.33	2.36	2.41	2.42	2.36	2.38	2.42	2.43	2.40	2.41	2.42	2.43
	CMP	2.12	2.15	2.20	2.21	2.13	2.15	2.19	2.20	2.14	2.15	2.16	2.17
	LDB	46.4	49.0	53.6	58.5	49.8	51.1	56.0	60.7	54.2	55.2	59.3	63.8
125 (51.7)	LWB	42.1	47.6	52.5	57.9	43.8	49.5	54.6	59.8	46.0	51.7	57.2	62.4
	TCG	15.5	16.3	18.4	20.3	16.7	17.2	19.2	21.2	18.3	18.3	20.1	22.1
	SHG	15.5	14.9	12.7	10.5	16.7	16.4	13.9	11.3	18.3	18.3	15.5	12.2
	TC	15.2	16.1	18.1	20.0	16.4	16.9	18.9	20.9	17.9	17.9	19.6	21.6
	kW	2.57	2.60	2.65	2.67	2.60	2.61	2.66	2.67	2.64	2.64	2.67	2.67
	CMP	2.36	2.39	2.44	2.46	2.37	2.38	2.43	2.44	2.38	2.38	2.41	2.41
125 (51.7)	LDB	48.6	50.1	54.9	59.6	51.6	52.4	57.0	61.8	55.9	56.0	60.0	64.7
	LWB	43.2	48.9	53.8	59.0	44.7	50.6	55.6	60.8	46.7	52.4	58.0	63.2

Rating condition

LEGEND

BF – Bypass Factor
 CMP – Compressor
 Edb – Entering Dry Bulb
 Ewb – Entering Wet Bulb
 kW – Total Power
 LDB – Leaving Dry Bulb
 LWB – Leaving Wet Bulb
 SHG – Gross Sensible Capacity (1000 Btu/hour)
 TC – Total Net Cooling Capacity (1000 Btu/hour)
 TCG – Gross Cooling Capacity (1000 Btu/hour)

NOTES:

- Direct interpolation is permissible. Do not extrapolate.
- The SHG is based on 80°F (26.67°C) edb temperature of air entering indoor coil.
 Below 80°F (26.67°C) edb, subtract (corr factor x cfm) from SHG.
 Above 80°F (26.67°C) edb, add (corr factor x cfm) to SHG.
 Correction Factor = 1.10 x (1 – BF) x (edb – 80).

40KMC, KMQ / 38HDF, QRF

PERFORMANCE DATA (CONT.)

COOLING CAPACITIES COOLING ONLY 38HDF030 WITH 40KMC03036

Temp °F (°C) Air Entering Condenser (Edb)	Air Entering Evaporator – Cfm/BF												
	635 / 0.05				720 / 0.05				875 / 0.05				
	Air Entering Evaporator – Ewb °F (°C)												
	57 (13.9)	62 (16.7)	67 (19.4)	72 (22.2)	57 (13.9)	62 (16.7)	67 (19.4)	72 (22.2)	57 (13.9)	62 (16.7)	67 (19.4)	72 (22.2)	
55 (12.8)	TCG	27.3	29.8	32.6	35.0	28.8	30.9	33.8	36.0	30.6	32.6	35.4	37.0
	SHG	25.9	23.7	20.7	17.4	27.8	25.3	21.9	18.1	30.6	27.9	24.3	19.0
	TC	26.8	29.4	32.1	34.5	28.1	30.3	33.2	35.4	29.8	31.8	34.7	36.2
	kW	1.56	1.57	1.58	1.59	1.57	1.57	1.59	1.59	1.57	1.59	1.58	1.61
	CMP	1.28	1.29	1.30	1.31	1.25	1.26	1.27	1.28	1.21	1.23	1.22	1.25
	LDB	43.3	46.8	51.5	56.6	45.4	48.9	53.5	58.6	48.7	51.8	55.8	61.6
65 (18.3)	LWB	39.4	44.7	50.0	55.8	41.0	46.4	51.8	57.6	43.3	48.9	54.2	60.2
	TCG	26.3	28.8	31.7	34.6	27.4	29.9	32.8	35.6	29.7	31.4	34.0	36.8
	SHG	25.4	23.3	20.3	17.2	27.4	24.9	21.6	18.1	29.7	28.2	23.0	19.2
	TC	25.8	28.3	31.2	34.1	26.8	29.3	32.2	35.0	29.0	30.7	33.2	36.1
	kW	1.73	1.75	1.77	1.78	1.74	1.76	1.76	1.78	1.76	1.75	1.78	1.78
	CMP	1.45	1.47	1.49	1.50	1.42	1.44	1.45	1.46	1.40	1.40	1.43	1.43
75 (23.9)	LDB	44.1	47.4	52.0	56.8	45.9	49.3	53.8	58.6	49.7	51.5	57.1	61.4
	LWB	40.3	45.4	50.5	56.0	41.8	47.1	52.3	57.7	43.7	49.4	54.8	60.2
	TCG	25.5	27.6	30.5	33.4	26.6	28.6	31.6	34.5	28.8	30.0	32.7	35.7
	SHG	24.5	22.8	20.0	16.8	26.6	24.4	21.1	17.7	28.8	26.5	22.6	18.9
	TC	25.0	27.1	30.0	32.9	26.0	28.0	31.0	33.9	28.0	29.2	32.0	35.0
	kW	1.92	1.94	1.96	1.98	1.93	1.95	1.97	1.98	1.96	1.97	1.98	1.99
85 (29.4)	CMP	1.64	1.66	1.68	1.70	1.62	1.64	1.65	1.66	1.60	1.61	1.63	1.63
	LDB	45.4	48.1	52.4	57.4	47.0	49.9	54.5	59.2	50.7	53.2	57.6	61.8
	LWB	40.8	46.2	51.3	56.6	42.4	47.8	52.9	58.3	44.2	50.1	55.3	60.6
	TCG	24.2	26.4	29.2	32.0	25.6	27.3	30.3	33.1	27.7	28.8	31.5	34.3
	SHG	24.2	22.2	19.5	16.0	25.6	24.0	20.5	17.1	27.7	26.3	22.4	18.4
	TC	23.7	25.9	28.7	31.5	25.0	26.7	29.6	32.5	27.0	28.0	30.8	33.6
95 (35.0)	kW	2.13	2.15	2.18	2.20	2.15	2.17	2.19	2.20	2.17	2.18	2.19	2.21
	CMP	1.85	1.87	1.90	1.92	1.83	1.85	1.87	1.88	1.82	1.83	1.84	1.85
	LDB	45.8	49.0	53.2	58.5	48.2	50.5	55.2	59.8	51.8	53.4	57.7	62.2
	LWB	41.8	47.0	52.1	57.4	43.0	48.5	53.6	58.9	44.8	50.6	55.8	61.1
	TCG	23.2	24.9	27.7	30.7	24.5	25.9	28.7	31.6	26.6	27.2	29.8	32.8
	SHG	23.2	21.7	18.6	15.7	24.5	23.3	19.9	16.6	26.6	25.6	21.7	17.8
105 (40.6)	TC	22.7	24.4	27.2	30.2	23.9	25.3	28.1	31.0	25.8	26.5	29.0	32.0
	kW	2.36	2.38	2.43	2.43	2.38	2.40	2.42	2.44	2.41	2.42	2.52	2.54
	CMP	2.08	2.10	2.15	2.15	2.06	2.08	2.11	2.12	2.05	2.07	2.17	2.19
	LDB	47.2	49.6	54.3	59.0	49.6	51.4	55.9	60.5	53.0	54.1	58.3	62.8
	LWB	42.5	48.0	53.0	58.1	43.7	49.4	54.4	59.6	45.3	51.3	56.4	61.7
	TCG	22.0	23.4	26.2	29.1	23.3	24.3	27.1	29.8	25.3	25.9	28.3	31.0
115 (46.1)	SHG	22.0	21.0	18.1	15.1	23.3	22.4	19.6	15.6	25.3	24.5	21.2	17.1
	TC	21.6	22.9	25.7	28.6	22.7	23.7	26.5	29.2	24.5	25.1	27.6	30.2
	kW	2.60	2.62	2.68	2.69	2.62	2.64	2.68	2.69	2.66	2.67	2.68	2.70
	CMP	2.32	2.34	2.40	2.41	2.31	2.32	2.37	2.38	2.31	2.32	2.33	2.35
	LDB	48.9	50.6	55.1	59.7	51.1	52.4	56.3	61.6	54.3	55.3	58.9	63.6
	LWB	43.4	49.0	53.9	58.9	44.4	50.2	55.2	60.4	46.0	51.9	57.1	62.3
125 (51.7)	TCG	20.8	21.7	24.4	27.3	22.0	22.5	25.2	28.0	23.8	24.1	26.3	29.0
	SHG	20.8	20.1	17.4	14.5	22.0	21.5	18.8	15.0	23.8	23.5	20.4	16.5
	TC	20.3	21.2	23.9	26.9	21.4	21.9	24.6	27.4	23.1	23.3	25.5	28.3
	kW	2.87	2.88	2.94	2.96	2.89	2.90	2.96	2.96	2.93	2.94	2.96	2.97
	CMP	2.59	2.60	2.66	2.68	2.58	2.58	2.64	2.65	2.58	2.58	2.60	2.62
	LDB	50.7	51.9	56.0	60.6	52.8	53.5	57.3	62.4	55.8	56.4	59.7	64.1
125 (51.7)	LWB	44.2	50.1	54.9	59.9	45.2	51.2	56.1	61.2	46.7	52.7	57.9	63.0
	TCG	19.4	19.8	22.4	25.3	20.6	20.8	23.2	26.0	22.3	22.3	24.2	26.8
	SHG	19.4	19.1	16.7	13.7	20.6	20.2	17.8	14.4	22.3	22.3	19.7	15.7
	TC	18.9	19.4	21.9	24.8	19.9	20.1	22.6	25.4	21.5	21.5	23.5	26.1
	kW	3.15	3.15	3.23	3.24	3.18	3.18	3.24	3.25	3.22	3.22	3.24	3.26
	CMP	2.87	2.87	2.95	2.96	2.86	2.86	2.92	2.93	2.87	2.87	2.88	2.90
125 (51.7)	LDB	52.7	53.3	57.1	61.7	54.6	55.2	58.5	63.1	57.4	57.6	60.5	64.9
	LWB	45.2	51.2	56.0	60.9	46.1	52.2	57.1	62.1	47.5	53.4	58.7	63.8

Rating condition

Not recommended for long-term operation.

LEGEND

BF – Bypass Factor
 CMP – Compressor
 Edb – Entering Dry Bulb
 Ewb – Entering Wet Bulb
 kW – Total Power
 LDB – Leaving Dry Bulb
 LWB – Leaving Wet Bulb
 SHG – Gross Sensible Capacity (1000 Btu/hour)
 TC – Total Net Cooling Capacity (1000 Btu/hour)
 TCG – Gross Cooling Capacity (1000 Btu/hour)

NOTES:

- Direct interpolation is permissible. Do not extrapolate.
- The SHG is based on 80°F (26.67°C) edb temperature of air entering indoor coil.
 Below 80°F (26.67°C) edb, subtract (corr factor x cfm) from SHG.
 Above 80°F (26.67°C) edb, add (corr factor x cfm) to SHG.
 Correction Factor = 1.10 x (1 - BF) x (edb - 80).

PERFORMANCE DATA (CONT.)

COOLING CAPACITIES COOLING ONLY 38HDF036 WITH 40KMC03036

Temp ° F (° C) Air Entering Condenser (Edb)	Air Entering Evaporator – Cfm/BF												
	635 / 0.05				720 / 0.05				875 / 0.05				
	Air Entering Evaporator – Ewb ° F (° C)												
	57 (13.9)	62 (16.7)	67 (19.4)	72 (22.2)	57 (13.9)	62 (16.7)	67 (19.4)	72 (22.2)	57 (13.9)	62 (16.7)	67 (19.4)	72 (22.2)	
55 (12.8)	TCG	33.0	36.3	39.7	43.0	34.8	38.1	40.9	44.6	36.6	39.8	43.2	45.7
	SHG	29.7	26.9	24.1	20.9	31.8	29.1	24.6	21.8	33.9	30.9	27.0	23.0
	TC	32.6	35.8	39.2	42.5	34.2	37.5	40.2	44.0	35.9	39.1	42.4	44.9
	kW	2.07	2.10	2.11	2.13	2.09	2.09	2.14	2.13	2.12	2.12	2.14	2.13
	CMP	1.65	1.68	1.69	1.71	1.63	1.63	1.68	1.67	1.62	1.62	1.64	1.63
	LDB	38.0	42.3	46.7	51.7	40.3	44.2	50.1	54.1	45.3	48.8	53.2	57.6
65 (18.3)	LWB	34.9	40.0	45.3	51.1	36.9	42.0	47.8	53.3	40.1	45.3	50.8	56.8
	TCG	32.1	35.3	38.8	42.2	33.7	36.7	40.4	43.5	35.8	39.0	42.1	45.0
	SHG	29.2	26.5	23.5	20.5	31.2	28.1	24.7	21.2	34.3	30.8	26.6	22.2
	TC	31.6	34.8	38.3	41.7	33.1	36.1	39.7	42.9	35.1	38.2	41.4	44.3
	kW	2.30	2.33	2.35	2.36	2.31	2.34	2.36	2.37	2.33	2.35	2.36	2.39
	CMP	1.87	1.91	1.92	1.94	1.85	1.88	1.90	1.91	1.83	1.85	1.86	1.89
75 (23.9)	LDB	38.6	42.9	47.6	52.2	41.1	45.4	50.1	54.8	44.9	48.8	53.5	58.5
	LWB	35.7	40.7	46.0	51.6	37.7	42.9	48.1	53.9	40.5	45.8	51.3	57.1
	TCG	30.9	34.1	37.6	40.9	32.4	35.6	39.1	42.5	34.9	37.5	40.8	44.0
	SHG	28.6	25.9	22.9	19.9	30.5	27.6	24.2	20.8	33.4	30.1	26.0	21.8
	TC	30.4	33.6	37.1	40.4	31.8	35.0	38.4	41.9	34.2	36.8	40.0	43.3
	kW	2.54	2.57	2.60	2.62	2.55	2.60	2.61	2.62	2.59	2.60	2.62	2.64
85 (29.4)	CMP	2.12	2.15	2.18	2.20	2.09	2.14	2.15	2.16	2.09	2.10	2.12	2.14
	LDB	39.5	43.7	48.4	53.1	42.0	46.0	50.7	55.3	45.8	49.5	54.1	58.8
	LWB	36.7	41.6	46.8	52.3	38.5	43.6	48.8	54.4	41.0	46.5	51.9	57.5
	TCG	29.7	32.8	36.2	39.3	31.1	34.2	37.6	41.0	33.8	36.0	39.4	42.5
	SHG	27.9	25.3	22.5	18.9	29.7	27.0	23.5	20.2	32.2	29.6	25.5	21.2
	TC	29.2	32.3	35.7	38.8	30.5	33.5	37.0	40.4	33.0	35.3	38.6	41.8
95 (35.0)	kW	2.81	2.84	2.89	2.90	2.82	2.86	2.89	2.91	2.86	2.89	2.90	2.92
	CMP	2.38	2.42	2.46	2.48	2.36	2.40	2.43	2.45	2.36	2.39	2.40	2.42
	LDB	40.5	44.6	49.0	54.5	43.0	46.8	51.5	56.1	47.1	50.1	54.7	59.4
	LWB	37.6	42.6	47.6	53.3	39.4	44.5	49.7	55.1	41.6	47.2	52.5	58.1
	TCG	28.2	31.3	34.7	38.2	29.8	32.6	35.9	39.4	31.9	34.4	37.2	41.1
	SHG	27.0	24.6	21.7	18.7	28.7	26.3	22.9	19.5	31.9	29.1	24.2	20.9
105 (40.6)	TC	27.7	30.8	34.2	37.7	29.2	32.0	35.3	38.8	31.1	33.7	36.4	40.4
	kW	3.10	3.13	3.20	3.21	3.11	3.15	3.21	3.22	3.15	3.19	3.31	3.32
	CMP	2.67	2.71	2.77	2.79	2.65	2.69	2.75	2.76	2.65	2.69	2.81	2.82
	LDB	41.7	45.6	50.1	54.8	44.2	47.6	52.2	56.9	47.4	50.6	55.5	59.7
	LWB	38.8	43.7	48.7	54.0	40.3	45.5	50.6	55.9	42.6	48.0	53.2	58.6
	TCG	26.8	29.6	33.0	36.4	28.1	30.8	34.2	37.4	30.5	32.5	35.9	39.2
115 (46.1)	SHG	26.1	23.8	20.9	17.7	28.1	25.5	22.3	18.4	30.5	28.3	24.0	20.1
	TC	26.3	29.1	32.5	35.9	27.5	30.2	33.6	36.7	29.7	31.8	35.2	38.5
	kW	3.41	3.45	3.52	3.55	3.43	3.47	3.55	3.55	3.48	3.51	3.54	3.57
	CMP	2.98	3.02	3.09	3.12	2.97	3.01	3.09	3.09	2.98	3.01	3.04	3.07
	LDB	43.1	46.6	51.1	56.1	45.0	48.6	53.0	58.3	48.9	51.4	56.2	60.6
	LWB	39.9	44.9	49.7	55.0	41.4	46.5	51.5	56.9	43.3	48.9	54.0	59.3
125 (51.7)	TCG	25.1	27.6	31.0	34.5	26.6	28.8	32.2	35.6	28.9	30.4	33.8	37.2
	SHG	25.1	23.0	20.1	17.0	26.6	24.7	21.4	17.9	28.9	27.5	23.3	19.4
	TC	24.6	27.1	30.5	34.0	26.0	28.2	31.6	35.0	28.1	29.7	33.1	36.4
	kW	3.75	3.79	3.87	3.91	3.77	3.81	3.90	3.92	3.83	3.86	3.91	3.94
	CMP	3.32	3.36	3.44	3.48	3.31	3.35	3.44	3.46	3.33	3.36	3.41	3.44
	LDB	44.5	47.8	52.3	57.1	46.9	49.6	54.1	58.9	50.5	52.2	56.9	61.2
125 (51.7)	LWB	41.1	46.2	51.0	56.1	42.3	47.7	52.6	57.7	44.2	49.8	54.8	60.1
	TCG	23.6	25.5	28.8	32.2	25.0	26.5	29.9	33.4	27.2	28.0	31.4	34.7
	SHG	23.6	22.1	19.2	16.1	25.0	23.8	20.5	17.2	27.2	26.3	22.4	18.5
	TC	23.1	25.0	28.3	31.7	24.4	25.9	29.3	32.7	26.4	27.3	30.7	33.9
	kW	4.12	4.15	4.25	4.30	4.15	4.18	4.28	4.32	4.21	4.23	4.30	4.33
	CMP	3.70	3.73	3.82	3.87	3.69	3.72	3.82	3.86	3.71	3.73	3.80	3.83
125 (51.7)	LDB	46.7	49.1	53.6	58.4	48.9	50.7	55.3	59.7	52.3	53.5	57.8	62.1
	LWB	42.3	47.6	52.3	57.3	43.4	49.0	53.8	58.8	45.0	50.9	55.8	61.0

Rating condition

LEGEND

BF – Bypass Factor
 CMP – Compressor
 Edb – Entering Dry Bulb
 Ewb – Entering Wet Bulb
 kW – Total Power
 LDB – Leaving Dry Bulb
 LWB – Leaving Wet Bulb
 SHG – Gross Sensible Capacity (1000 Btu/hour)
 TC – Total Net Cooling Capacity (1000 Btu/hour)
 TCG – Gross Cooling Capacity (1000 Btu/hour)

NOTES:

- Direct interpolation is permissible. Do not extrapolate.
- The SHG is based on 80°F (26.67°C) edb temperature of air entering indoor coil.
 Below 80°F (26.67°C) edb, subtract (corr factor x cfm) from SHG.
 Above 80°F (26.67°C) edb, add (corr factor x cfm) to SHG.
 Correction Factor = 1.10 x (1 - BF) x (edb - 80).

40KMC, KMQ / 38HDF, QRF

PERFORMANCE DATA (CONT.)

COOLING CAPACITIES HEAT / COOL 38HDF018 WITH 40KMQ01824

Temp °F (°C) Air Entering Condenser (Edb)	Air Entering Evaporator – Cfm/BF												
	445 / 0.05				530 / 0.05				680 / 0.05				
	Air Entering Evaporator – Ewb °F (°C)												
	57 (13.9)	62 (16.7)	67 (19.4)	72 (22.2)	57 (13.9)	62 (16.7)	67 (19.4)	72 (22.2)	57 (13.9)	62 (16.7)	67 (19.4)	72 (22.2)	
55 (12.8)	TCG	17.0	18.0	19.4	20.6	17.8	19.0	20.0	21.1	18.9	19.7	20.7	21.4
	SHG	14.7	13.6	11.9	10.1	15.5	15.0	12.5	10.5	18.9	15.7	13.3	10.9
	TC	16.7	17.7	19.2	20.4	17.4	18.7	19.7	20.7	18.5	19.3	20.3	21.0
	kW	1.01	1.00	1.01	1.01	1.00	1.00	1.02	1.00	1.00	1.01	1.01	1.00
	CMP	0.80	0.79	0.80	0.80	0.77	0.77	0.79	0.77	0.74	0.75	0.75	0.74
	LDB	50.3	52.9	56.6	60.6	53.8	55.0	59.5	63.1	55.1	59.7	63.0	66.5
65 (18.3)	LWB	41.7	47.4	52.9	58.7	43.8	49.3	55.1	60.9	46.3	52.1	57.7	63.5
	TCG	16.7	17.4	19.1	20.2	17.2	18.2	19.7	20.7	18.8	19.0	20.3	21.2
	SHG	14.8	13.5	11.9	9.9	17.2	14.4	12.5	10.4	18.8	15.6	13.3	11.0
	TC	16.5	17.2	18.9	20.0	16.9	17.9	19.3	20.4	18.3	18.6	19.9	20.8
	kW	1.12	1.12	1.12	1.13	1.11	1.13	1.13	1.13	1.11	1.12	1.13	1.12
	CMP	0.91	0.91	0.91	0.92	0.88	0.90	0.90	0.90	0.85	0.86	0.87	0.86
75 (23.9)	LDB	50.1	53.1	56.5	60.9	50.7	55.9	59.5	63.3	55.3	59.8	63.0	66.3
	LWB	41.9	48.0	53.2	59.0	44.3	49.9	55.3	61.1	46.4	52.5	57.9	63.6
	TCG	15.7	17.1	18.3	19.7	16.8	17.5	19.1	20.2	18.2	18.4	19.7	20.7
	SHG	15.7	13.7	11.6	9.8	16.8	14.1	12.5	10.2	18.2	15.5	13.3	10.9
	TC	15.5	16.9	18.1	19.4	16.5	17.2	18.8	19.9	17.8	17.9	19.3	20.2
	kW	1.25	1.25	1.26	1.26	1.25	1.26	1.25	1.26	1.25	1.26	1.26	1.25
85 (29.4)	CMP	1.04	1.04	1.05	1.05	1.02	1.03	1.02	1.03	0.99	1.00	1.00	0.99
	LDB	48.2	52.6	57.3	61.2	51.5	56.4	59.4	63.6	56.0	59.9	63.1	66.5
	LWB	43.0	48.2	53.8	59.4	44.6	50.5	55.7	61.4	46.8	52.8	58.2	63.8
	TCG	15.2	16.5	17.6	19.0	16.2	17.0	18.3	19.6	17.6	17.7	19.1	20.1
	SHG	15.2	13.5	11.3	9.5	16.2	14.4	12.1	10.0	17.6	15.2	13.1	10.6
	TC	15.0	16.2	17.3	18.8	15.8	16.7	18.0	19.2	17.2	17.3	18.7	19.6
95 (35.0)	kW	1.39	1.40	1.40	1.40	1.40	1.40	1.40	1.41	1.40	1.40	1.40	1.41
	CMP	1.18	1.19	1.19	1.19	1.17	1.17	1.17	1.18	1.14	1.14	1.14	1.15
	LDB	49.1	52.9	57.9	61.7	52.6	55.9	60.1	64.0	56.8	60.3	63.3	66.8
	LWB	43.5	48.8	54.4	59.9	45.2	50.8	56.2	61.8	47.2	53.2	58.5	64.1
	TCG	14.6	15.7	16.8	18.3	15.5	16.2	17.5	18.8	16.9	17.1	17.4	19.3
	SHG	14.6	13.4	11.0	9.2	15.5	14.1	11.9	9.7	16.9	14.9	12.4	10.4
105 (40.6)	TC	14.3	15.4	16.5	18.1	15.2	15.9	17.2	18.5	16.5	16.6	17.0	18.9
	kW	1.55	1.56	1.56	1.56	1.56	1.56	1.56	1.57	1.56	1.56	1.55	1.57
	CMP	1.34	1.35	1.35	1.35	1.33	1.33	1.33	1.34	1.30	1.30	1.29	1.31
	LDB	50.5	53.2	58.4	62.3	53.7	56.4	60.4	64.4	57.7	60.7	63.3	67.1
	LWB	44.1	49.5	55.1	60.4	45.7	51.4	56.8	62.2	47.6	53.5	58.9	64.4
	TCG	13.8	14.8	15.8	17.3	14.8	15.5	16.5	18.0	16.2	16.3	17.2	18.5
115 (46.1)	SHG	13.8	12.9	10.5	8.7	14.8	13.4	11.5	9.4	16.2	13.4	12.6	10.1
	TC	13.6	14.5	15.6	17.1	14.4	15.2	16.2	17.7	15.7	15.9	16.8	18.0
	kW	1.72	1.73	1.74	1.74	1.73	1.73	1.74	1.74	1.74	1.74	1.74	1.74
	CMP	1.51	1.52	1.53	1.53	1.50	1.50	1.51	1.51	1.48	1.48	1.48	1.48
	LDB	52.0	54.2	59.4	63.4	55.0	57.6	61.1	64.9	58.8	62.7	63.9	67.5
	LWB	44.9	50.3	55.9	61.2	46.3	51.9	57.4	62.7	48.1	53.9	59.4	64.8
125 (51.7)	TCG	13.1	13.9	15.0	16.4	13.9	13.9	15.4	16.9	15.2	15.0	16.1	17.4
	SHG	13.1	12.2	10.3	8.5	13.9	13.9	11.1	9.0	15.2	15.0	12.4	9.7
	TC	12.8	13.7	14.7	16.1	13.5	13.6	15.0	16.5	14.8	14.6	15.7	17.0
	kW	1.90	1.91	1.92	1.93	1.91	1.91	1.93	1.93	1.93	1.93	1.93	1.93
	CMP	1.69	1.70	1.71	1.72	1.68	1.68	1.70	1.70	1.67	1.67	1.67	1.67
	LDB	53.6	55.7	59.7	63.7	56.6	56.7	61.7	65.6	60.0	60.4	64.2	68.0
125 (51.7)	LWB	45.7	51.1	56.5	61.8	47.0	52.6	58.2	63.4	48.6	54.6	59.9	65.2
	TCG	12.1	12.1	13.7	15.0	12.9	12.9	14.1	15.6	14.2	13.9	14.8	16.0
	SHG	12.1	12.1	10.0	8.1	12.9	12.9	10.7	8.6	14.2	13.9	12.2	9.2
	TC	11.9	11.9	13.5	14.8	12.6	12.6	13.8	15.3	13.7	13.5	14.3	15.6
	kW	2.09	2.09	2.12	2.13	2.11	2.10	2.12	2.13	2.13	2.13	2.13	2.13
	CMP	1.88	1.88	1.91	1.92	1.88	1.87	1.89	1.90	1.87	1.87	1.87	1.87
125 (51.7)	LDB	55.5	55.6	60.2	64.6	58.3	58.4	62.4	66.3	61.5	61.9	64.4	68.6
	LWB	46.6	52.6	57.5	62.7	47.8	53.8	58.9	64.1	49.3	55.2	60.6	65.8

Rating condition
Not recommended for long-term operation.

LEGEND

BF – Bypass Factor
CMP – Compressor
Edb – Entering Dry Bulb
Ewb – Entering Wet Bulb
kW – Total Power
LDB – Leaving Dry Bulb
LWB – Leaving Wet Bulb
SHG – Gross Sensible Capacity (1000 Btu/hour)
TC – Total Net Cooling Capacity (1000 Btu/hour)
TCG – Gross Cooling Capacity (1000 Btu/hour)

NOTES:

- Direct interpolation is permissible. Do not extrapolate.
- The SHG is based on 80°F (26.67°C) edb temperature of air entering indoor coil.
Below 80°F (26.67°C) edb, subtract (corr factor x cfm) from SHG.
Above 80°F (26.67°C) edb, add (corr factor x cfm) to SHG.
Correction Factor = 1.10 x (1 - BF) x (edb - 80).

PERFORMANCE DATA (CONT.)

COOLING CAPACITIES HEAT / COOL 38HDF024 WITH 40KMQ01824

Temp °F (°C) Air Entering Condenser (Edb)	Air Entering Evaporator – Cfm/BF												
	445 / 0.05				530 / 0.05				680 / 0.05				
	Air Entering Evaporator – Ewb °F (°C)												
	57 (13.9)	62 (16.7)	67 (19.4)	72 (22.2)	57 (13.9)	62 (16.7)	67 (19.4)	72 (22.2)	57 (13.9)	62 (16.7)	67 (19.4)	72 (22.2)	
55 (12.8)	TCG	21.4	23.3	25.0	27.0	22.7	24.5	26.2	28.5	24.3	25.6	28.0	29.0
	SHG	19.7	17.6	15.4	13.5	21.2	18.9	16.1	14.2	22.8	20.3	18.1	14.9
	TC	21.2	23.0	24.7	26.8	22.4	24.1	25.9	28.1	23.9	25.2	27.5	28.6
	kW	1.20	1.22	1.23	1.23	1.22	1.23	1.24	1.23	1.22	1.24	1.23	1.22
	CMP	0.99	1.01	1.02	1.02	0.99	1.00	1.01	1.00	0.96	0.98	0.97	0.96
	LDB	40.0	44.6	49.6	53.8	44.0	48.1	53.3	56.9	49.9	53.5	56.7	61.3
65 (18.3)	LWB	36.8	42.2	48.0	53.6	39.5	45.0	50.7	56.2	42.8	48.6	53.9	60.0
	TCG	20.7	22.6	24.7	26.3	22.1	23.8	25.5	27.7	23.5	25.1	26.7	28.6
	SHG	19.4	17.4	15.2	13.0	20.7	18.9	15.8	13.6	23.4	20.7	17.1	14.4
	TC	20.4	22.4	24.4	26.0	21.7	23.5	25.2	27.4	23.0	24.7	26.3	28.2
	kW	1.35	1.37	1.39	1.39	1.37	1.38	1.40	1.40	1.38	1.39	1.40	1.41
	CMP	1.14	1.16	1.18	1.18	1.14	1.15	1.17	1.17	1.12	1.13	1.14	1.15
75 (23.9)	LDB	40.6	45.1	49.9	54.7	44.7	48.3	53.8	58.0	49.0	52.9	58.1	61.9
	LWB	37.6	42.8	48.3	54.3	40.1	45.5	51.2	56.7	43.4	48.9	54.5	60.2
	TCG	19.9	21.9	23.9	25.8	21.7	23.0	25.0	27.0	22.8	24.4	26.4	28.1
	SHG	18.9	17.0	14.9	12.5	19.7	18.6	16.1	13.5	22.8	20.8	17.4	14.2
	TC	19.7	21.6	23.7	25.5	21.4	22.7	24.7	26.6	22.4	24.0	26.0	27.7
	kW	1.52	1.54	1.56	1.57	1.53	1.55	1.56	1.57	1.55	1.56	1.57	1.58
85 (29.4)	CMP	1.31	1.33	1.35	1.36	1.30	1.32	1.33	1.34	1.29	1.30	1.31	1.32
	LDB	41.6	45.8	50.6	55.8	46.5	48.8	53.4	58.1	49.8	52.7	57.6	62.2
	LWB	38.5	43.6	48.9	54.7	40.4	46.2	51.6	57.2	43.8	49.3	54.7	60.4
	TCG	19.2	21.0	23.0	24.9	20.2	22.1	23.9	26.5	22.1	23.5	25.5	27.4
	SHG	18.4	16.6	14.5	12.3	20.2	18.1	15.4	13.3	22.1	20.6	17.2	14.0
	TC	19.0	20.7	22.8	24.6	19.9	21.7	23.6	26.1	21.7	23.1	25.1	27.0
95 (35.0)	kW	1.70	1.72	1.75	1.76	1.71	1.74	1.75	1.76	1.73	1.75	1.76	1.77
	CMP	1.49	1.51	1.54	1.55	1.48	1.51	1.52	1.53	1.47	1.49	1.50	1.51
	LDB	42.8	46.6	51.4	56.3	45.6	49.5	54.5	58.5	50.8	53.1	57.9	62.4
	LWB	39.3	44.5	49.7	55.4	41.7	46.9	52.4	57.5	44.3	49.8	55.2	60.7
	TCG	18.5	20.0	22.0	23.9	19.4	21.0	22.9	25.4	21.2	22.4	23.0	26.2
	SHG	17.6	16.2	14.0	11.8	19.4	17.7	15.0	12.8	21.2	20.1	15.8	13.6
105 (40.6)	TC	18.3	19.7	21.8	23.7	19.1	20.7	22.6	25.1	20.8	22.0	22.6	25.8
	kW	1.89	1.92	1.95	1.96	1.91	1.93	1.96	1.97	1.93	1.95	2.05	2.06
	CMP	1.68	1.71	1.74	1.75	1.68	1.70	1.73	1.74	1.67	1.69	1.79	1.80
	LDB	44.3	47.5	52.2	57.1	47.0	50.2	55.3	59.3	51.9	53.6	58.6	63.0
	LWB	40.0	45.5	50.6	56.2	42.4	47.7	53.1	58.2	44.8	50.5	55.8	61.3
	TCG	17.3	18.9	20.9	22.8	18.5	19.8	21.9	24.0	20.3	21.1	22.9	24.9
115 (46.1)	SHG	17.3	15.7	13.6	11.3	18.5	17.2	14.7	12.1	20.3	19.5	16.1	13.1
	TC	17.0	18.6	20.7	22.5	18.2	19.5	21.5	23.7	19.9	20.6	22.5	24.5
	kW	2.10	2.13	2.17	2.18	2.12	2.14	2.18	2.19	2.15	2.17	2.18	2.19
	CMP	1.89	1.92	1.96	1.97	1.89	1.91	1.95	1.96	1.89	1.91	1.92	1.93
	LDB	44.9	48.5	53.2	58.3	48.5	51.0	55.7	60.4	53.2	54.5	59.3	63.6
	LWB	41.3	46.6	51.6	57.1	43.2	48.7	53.8	59.1	45.5	51.2	56.5	61.9
125 (51.7)	TCG	16.4	17.6	19.6	21.5	17.5	18.4	20.5	22.6	19.2	19.8	21.4	23.5
	SHG	16.4	15.1	13.0	10.8	17.5	16.7	14.2	11.6	19.2	18.6	15.4	12.6
	TC	16.1	17.3	19.4	21.3	17.2	18.1	20.2	22.3	18.8	19.4	20.9	23.0
	kW	2.32	2.35	2.39	2.41	2.35	2.36	2.41	2.42	2.38	2.40	2.41	2.42
	CMP	2.11	2.14	2.18	2.20	2.12	2.13	2.18	2.19	2.12	2.14	2.15	2.16
	LDB	46.8	49.6	54.2	59.3	50.2	51.9	56.6	61.3	54.7	55.7	60.2	64.3
125 (51.7)	LWB	42.3	47.8	52.7	58.0	44.0	49.7	54.7	60.0	46.2	52.0	57.3	62.5
	TCG	15.3	16.1	18.1	20.1	16.4	17.0	19.0	21.0	18.0	18.0	19.9	21.8
	SHG	15.3	14.6	12.5	10.2	16.4	15.9	13.6	11.0	18.0	18.0	15.1	12.0
	TC	15.0	15.8	17.9	19.8	16.1	16.7	18.6	20.7	17.6	17.6	19.5	21.4
	kW	2.56	2.58	2.63	2.66	2.59	2.60	2.65	2.66	2.62	2.62	2.66	2.67
	CMP	2.35	2.37	2.42	2.45	2.36	2.37	2.42	2.43	2.36	2.36	2.40	2.41
125 (51.7)	LDB	49.0	50.8	55.4	60.4	52.2	53.2	57.5	62.3	56.3	56.4	60.6	65.0
	LWB	43.4	49.2	54.0	59.1	45.0	50.8	55.8	60.9	46.9	52.7	58.1	63.3

Rating condition

LEGEND

BF – Bypass Factor
 CMP – Compressor
 Edb – Entering Dry Bulb
 Ewb – Entering Wet Bulb
 kW – Total Power
 LDB – Leaving Dry Bulb
 LWB – Leaving Wet Bulb
 SHG – Gross Sensible Capacity (1000 Btu/hour)
 TC – Total Net Cooling Capacity (1000 Btu/hour)
 TCG – Gross Cooling Capacity (1000 Btu/hour)

NOTES:

- Direct interpolation is permissible. Do not extrapolate.
- The SHG is based on 80°F (26.67°C) edb temperature of air entering indoor coil.
 Below 80°F (26.67°C) edb, subtract (corr factor x cfm) from SHG.
 Above 80°F (26.67°C) edb, add (corr factor x cfm) to SHG.
 Correction Factor = 1.10 x (1 – BF) x (edb – 80).

40KMC, KMQ / 38HDF, QRF

PERFORMANCE DATA (CONT.)

COOLING CAPACITIES HEAT / COOL 38HDF030 WITH 40KMQ03036

Temp ° F (° C) Air Entering Condenser (Edb)	Air Entering Evaporator – Cfm/BF												
	635 / 0.05				720 / 0.05				875 / 0.05				
	Air Entering Evaporator – Ewb ° F (° C)												
	57 (13.9)	62 (16.7)	67 (19.4)	72 (22.2)	57 (13.9)	62 (16.7)	67 (19.4)	72 (22.2)	57 (13.9)	62 (16.7)	67 (19.4)	72 (22.2)	
55 (12.8)	TCG	28.3	30.5	33.3	35.3	29.4	31.5	34.4	36.0	31.4	32.9	35.0	37.0
	SHG	27.6	24.7	21.4	17.5	29.4	26.3	22.5	18.3	31.4	29.0	23.7	19.2
	TC	27.8	30.0	32.8	34.8	28.8	30.9	33.7	35.4	30.7	32.2	34.3	36.3
	kW	1.55	1.56	1.57	1.59	1.56	1.56	1.58	1.58	1.56	1.57	1.58	1.59
	CMP	1.27	1.28	1.29	1.31	1.24	1.25	1.26	1.26	1.21	1.21	1.23	1.23
	LDB	40.9	45.4	50.5	56.4	43.4	47.6	52.7	58.4	47.9	50.6	56.5	61.4
65 (18.3)	LWB	38.7	44.2	49.5	55.6	40.6	46.1	51.4	57.6	42.8	48.7	54.4	60.1
	TCG	27.1	29.5	32.3	35.0	28.6	30.5	33.3	36.0	30.9	31.8	34.6	37.0
	SHG	27.1	24.3	21.0	17.5	28.5	26.2	22.4	18.3	30.9	28.8	24.1	19.4
	TC	26.6	29.0	31.8	34.5	27.9	29.9	32.7	35.4	30.2	31.1	33.9	36.2
	kW	1.72	1.74	1.75	1.77	1.73	1.74	1.75	1.77	1.74	1.75	1.76	1.77
	CMP	1.44	1.46	1.47	1.49	1.42	1.43	1.44	1.45	1.38	1.39	1.41	1.42
75 (23.9)	LDB	41.6	45.9	51.1	56.5	44.4	47.8	52.9	58.4	48.4	50.8	56.0	61.2
	LWB	39.6	44.9	50.2	55.8	41.1	46.7	52.0	57.6	43.1	49.2	54.5	60.2
	TCG	26.2	28.3	31.1	33.9	27.6	29.3	32.1	34.8	29.7	30.5	33.4	35.9
	SHG	26.2	23.7	20.5	17.1	27.6	25.5	21.7	17.9	29.7	28.2	23.7	19.1
	TC	25.7	27.8	30.6	33.4	27.0	28.7	31.5	34.2	29.0	29.7	32.6	35.1
	kW	1.92	1.94	1.95	1.97	1.93	1.95	1.96	1.97	1.94	1.95	1.96	1.97
85 (29.4)	CMP	1.64	1.66	1.67	1.69	1.61	1.63	1.64	1.65	1.59	1.60	1.61	1.62
	LDB	42.9	46.8	51.8	57.0	45.7	48.6	53.7	58.9	49.7	51.5	56.4	61.5
	LWB	40.3	45.7	50.9	56.4	41.7	47.4	52.6	58.1	43.7	49.8	55.0	60.6
	TCG	25.2	26.9	29.8	32.6	26.6	28.0	30.7	33.4	28.5	29.1	31.9	34.5
	SHG	25.2	23.2	19.9	16.6	26.6	25.0	21.2	17.4	28.5	27.4	23.2	18.6
	TC	24.7	26.4	29.3	32.1	25.9	27.3	30.1	32.8	27.8	28.3	31.1	33.7
95 (35.0)	kW	2.13	2.15	2.17	2.18	2.14	2.16	2.17	2.19	2.17	2.17	2.18	2.19
	CMP	1.85	1.87	1.89	1.90	1.83	1.85	1.86	1.87	1.81	1.82	1.82	1.84
	LDB	44.4	47.6	52.6	57.7	47.0	49.2	54.4	59.4	50.9	52.3	56.9	62.0
	LWB	41.1	46.6	51.7	57.1	42.4	48.2	53.4	58.8	44.3	50.5	55.6	61.1
	TCG	24.1	25.5	28.3	31.2	25.4	26.4	29.2	31.9	27.4	27.6	29.8	32.9
	SHG	24.1	22.5	19.3	16.0	25.4	24.2	20.5	16.8	27.4	26.8	22.2	18.0
105 (40.6)	TC	23.6	25.0	27.8	30.7	24.8	25.7	28.6	31.3	26.6	26.9	29.0	32.1
	kW	2.36	2.38	2.41	2.42	2.38	2.39	2.41	2.42	2.41	2.41	2.63	2.64
	CMP	2.08	2.10	2.13	2.14	2.06	2.08	2.10	2.11	2.05	2.05	2.06	2.08
	LDB	46.0	48.5	53.4	58.5	48.4	50.2	55.1	60.2	52.1	52.8	57.5	62.6
	LWB	41.9	47.6	52.6	57.9	43.1	49.1	54.1	59.5	44.9	51.1	56.3	61.7
	TCG	22.8	23.9	26.7	29.5	24.1	25.4	27.6	30.3	26.2	26.5	28.7	31.1
115 (46.1)	SHG	22.8	21.7	18.7	15.4	24.1	22.8	19.9	16.2	26.2	25.2	22.0	17.4
	TC	22.4	23.4	26.2	29.0	23.5	24.8	27.0	29.7	25.4	25.8	27.9	30.4
	kW	2.60	2.62	2.67	2.68	2.63	2.64	2.67	2.68	2.66	2.66	2.67	2.69
	CMP	2.32	2.34	2.39	2.40	2.31	2.33	2.35	2.37	2.31	2.30	2.32	2.33
	LDB	47.7	49.6	54.3	59.4	50.1	51.9	55.9	60.9	53.4	54.5	58.2	63.2
	LWB	42.8	48.6	53.6	58.7	43.9	49.6	55.0	60.2	45.5	51.6	56.9	62.3
125 (51.7)	TCG	21.5	22.0	24.8	27.7	22.7	23.4	25.5	28.4	24.7	24.6	26.6	29.2
	SHG	21.5	20.9	17.9	14.7	22.7	22.1	19.1	15.5	24.7	24.6	21.2	16.7
	TC	21.0	21.5	24.3	27.2	22.1	22.7	24.9	27.8	23.9	23.8	25.9	28.4
	kW	2.87	2.88	2.94	2.95	2.89	2.90	2.94	2.95	2.93	2.93	2.94	2.96
	CMP	2.59	2.60	2.66	2.67	2.58	2.59	2.62	2.64	2.58	2.58	2.59	2.60
	LDB	49.7	50.8	55.3	60.3	51.8	52.9	56.9	61.8	54.9	55.2	58.9	63.9
125 (51.7)	LWB	43.8	49.8	54.7	59.7	44.8	50.8	56.0	61.1	46.3	52.5	57.7	63.0
	TCG	20.0	20.5	22.8	25.7	21.2	21.2	23.6	26.3	23.0	22.9	24.5	26.9
	SHG	20.0	19.6	17.1	13.9	21.2	21.2	18.4	14.7	23.0	22.9	20.4	15.8
	TC	19.5	20.0	22.3	25.2	20.6	20.6	23.0	25.6	22.2	22.2	23.8	26.2
	kW	3.15	3.16	3.22	3.23	3.18	3.18	3.22	3.23	3.22	3.21	3.23	3.24
	CMP	2.87	2.88	2.94	2.95	2.87	2.86	2.90	2.92	2.86	2.86	2.87	2.89
125 (51.7)	LDB	51.8	52.6	56.5	61.3	53.8	53.9	57.7	62.7	56.7	56.9	59.8	64.7
	LWB	44.8	50.8	55.8	60.7	45.8	51.5	56.9	62.0	47.1	53.2	58.5	63.7

Rating condition
Not recommended for long-term operation.

LEGEND

BF – Bypass Factor
 CMP – Compressor
 Edb – Entering Dry Bulb
 Ewb – Entering Wet Bulb
 kW – Total Power
 LDB – Leaving Dry Bulb
 LWB – Leaving Wet Bulb
 SHG – Gross Sensible Capacity (1000 Btu/hour)
 TC – Total Net Cooling Capacity (1000 Btu/hour)
 TCG – Gross Cooling Capacity (1000 Btu/hour)

NOTES:

- Direct interpolation is permissible. Do not extrapolate.
- The SHG is based on 80°F (26.67°C) edb temperature of air entering indoor coil.
 Below 80°F (26.67°C) edb, subtract (corr factor x cfm) from SHG.
 Above 80°F (26.67°C) edb, add (corr factor x cfm) to SHG.
 Correction Factor = 1.10 x (1 - BF) x (edb - 80).

PERFORMANCE DATA (CONT.)

COOLING CAPACITIES HEAT / COOL 38HDF036 WITH 40KMQ03036

Temp °F (°C) Air Entering Condenser (Edb)	Air Entering Evaporator – Cfm/BF												
	635 / 0.05				720 / 0.05				875 / 0.05				
	Air Entering Evaporator – Ewb °F (°C)												
	57 (13.9)	62 (16.7)	67 (19.4)	72 (22.2)	57 (13.9)	62 (16.7)	67 (19.4)	72 (22.2)	57 (13.9)	62 (16.7)	67 (19.4)	72 (22.2)	
55 (12.8)	TCG	34.7	37.8	41.1	43.9	36.3	39.4	42.6	45.2	38.5	41.5	44.5	46.5
	SHG	32.0	28.5	25.1	21.7	34.5	30.6	26.3	22.7	37.6	33.3	28.4	23.7
	TC	34.3	37.3	40.6	43.4	35.7	38.8	42.0	44.6	37.8	40.8	43.8	45.8
	kW	2.08	2.11	2.12	2.12	2.09	2.11	2.13	2.12	2.10	2.12	2.14	2.11
	CMP	1.65	1.68	1.70	1.69	1.63	1.65	1.67	1.66	1.60	1.62	1.64	1.61
	LDB	34.6	40.0	45.3	50.5	36.8	42.2	48.0	53.0	41.4	46.3	51.7	56.9
65 (18.3)	LWB	33.5	38.8	44.4	50.5	35.8	41.2	46.8	53.0	39.0	44.5	50.2	56.5
	TCG	33.5	36.9	40.3	43.4	35.1	38.3	41.7	44.8	37.8	40.3	43.6	46.1
	SHG	31.3	28.1	24.8	21.1	33.6	29.8	26.0	22.1	37.2	32.7	28.1	23.2
	TC	33.0	36.4	39.8	42.9	34.4	37.7	41.1	44.2	37.0	39.6	42.9	45.4
	kW	2.31	2.33	2.34	2.37	2.32	2.34	2.36	2.37	2.33	2.35	2.36	2.38
	CMP	1.88	1.91	1.92	1.94	1.86	1.88	1.90	1.91	1.83	1.85	1.86	1.88
75 (23.9)	LDB	35.5	40.5	45.7	51.3	38.0	43.2	48.4	53.8	41.8	46.9	52.0	57.5
	LWB	34.6	39.5	44.9	50.8	36.7	41.9	47.3	53.2	39.4	45.1	50.6	56.6
	TCG	32.3	35.5	39.1	42.3	33.7	36.9	40.4	43.7	36.7	38.9	42.3	45.2
	SHG	30.6	27.5	24.2	20.7	32.8	29.2	25.5	21.6	35.2	32.2	27.6	22.8
	TC	31.8	35.0	38.6	41.8	33.1	36.3	39.8	43.1	35.9	38.2	41.6	44.5
	kW	2.55	2.59	2.60	2.62	2.57	2.60	2.61	2.63	2.59	2.60	2.62	2.64
85 (29.4)	CMP	2.13	2.16	2.18	2.20	2.11	2.14	2.15	2.17	2.09	2.10	2.12	2.14
	LDB	36.6	41.5	46.5	52.0	39.0	44.0	49.0	54.3	43.9	47.4	52.5	57.8
	LWB	35.5	40.5	45.7	51.5	37.6	42.8	48.1	53.8	40.0	45.8	51.2	57.0
	TCG	30.8	34.1	37.6	41.0	32.4	35.5	39.0	42.3	34.9	37.4	40.8	43.7
	SHG	29.8	26.8	23.4	20.1	31.9	28.6	24.8	21.0	34.9	31.6	27.0	22.2
	TC	30.3	33.6	37.1	40.5	31.8	34.9	38.3	41.7	34.2	36.7	40.1	42.9
95 (35.0)	kW	2.82	2.86	2.89	2.90	2.84	2.88	2.89	2.91	2.88	2.88	2.90	2.92
	CMP	2.39	2.44	2.46	2.48	2.38	2.42	2.43	2.45	2.38	2.38	2.40	2.42
	LDB	37.7	42.4	47.6	52.8	40.2	44.7	49.9	55.1	44.2	48.0	53.1	58.4
	LWB	36.7	41.6	46.8	52.3	38.5	43.7	48.9	54.5	41.0	46.5	51.9	57.6
	TCG	29.3	32.5	36.0	39.5	31.1	33.8	37.3	40.7	33.5	35.8	38.8	42.1
	SHG	28.9	26.0	22.7	19.4	30.6	27.8	24.1	20.3	33.5	30.9	27.0	21.6
105 (40.6)	TC	28.8	32.0	35.5	39.0	30.5	33.2	36.7	40.1	32.8	35.0	38.0	41.3
	kW	3.11	3.15	3.19	3.21	3.13	3.18	3.20	3.22	3.18	3.19	3.27	3.28
	CMP	2.68	2.73	2.77	2.79	2.67	2.72	2.74	2.76	2.68	2.69	2.77	2.78
	LDB	39.0	43.6	48.6	53.7	41.9	45.7	50.8	55.9	45.6	48.7	53.8	59.0
	LWB	37.9	42.8	47.8	53.2	39.4	44.7	49.8	55.3	41.7	47.3	52.6	58.2
	TCG	27.7	30.6	34.0	37.8	29.4	31.9	35.5	38.9	32.0	33.7	37.1	40.3
115 (46.1)	SHG	27.7	25.0	21.7	18.7	29.4	26.9	23.3	19.6	32.0	30.0	25.4	20.9
	TC	27.2	30.1	33.5	37.3	28.8	31.3	34.9	38.3	31.2	33.0	36.4	39.5
	kW	3.42	3.47	3.53	3.55	3.45	3.50	3.54	3.56	3.51	3.53	3.55	3.58
	CMP	3.00	3.04	3.11	3.13	2.99	3.04	3.08	3.10	3.01	3.03	3.05	3.08
	LDB	40.8	44.9	50.0	54.8	43.3	46.8	51.7	56.8	47.3	49.6	54.7	59.7
	LWB	39.1	44.1	49.1	54.2	40.5	45.9	50.8	56.2	42.6	48.3	53.5	58.9
125 (51.7)	TCG	26.2	28.5	32.2	35.8	27.8	29.7	33.3	36.8	30.2	31.5	35.0	38.1
	SHG	26.2	24.0	21.1	17.9	27.8	25.9	22.4	18.8	30.2	29.0	24.7	20.1
	TC	25.7	28.0	31.7	35.3	27.2	29.1	32.7	36.2	29.5	30.7	34.2	37.4
	kW	3.77	3.81	3.90	3.92	3.80	3.84	3.90	3.93	3.86	3.89	3.91	3.94
	CMP	3.34	3.38	3.47	3.49	3.34	3.38	3.44	3.47	3.36	3.39	3.41	3.44
	LDB	42.9	46.3	50.9	55.8	45.4	48.1	52.9	57.8	49.1	50.6	55.5	60.5
125 (51.7)	LWB	40.3	45.6	50.3	55.3	41.6	47.1	52.0	57.2	43.5	49.4	54.4	59.7
	TCG	24.5	26.2	29.8	33.4	26.0	27.4	30.9	34.4	28.3	30.0	32.5	35.6
	SHG	24.5	22.9	20.1	17.0	26.0	24.8	21.3	17.9	28.3	26.9	23.7	19.1
	TC	24.0	25.7	29.3	32.9	25.4	26.8	30.3	33.7	27.6	29.2	31.7	34.8
	kW	4.14	4.18	4.28	4.30	4.17	4.21	4.29	4.31	4.25	4.25	4.30	4.33
	CMP	3.72	3.75	3.86	3.88	3.71	3.75	3.83	3.85	3.75	3.75	3.80	3.83
125 (51.7)	LDB	45.4	47.8	52.3	57.1	47.6	49.4	54.2	58.9	51.1	52.8	56.4	61.5
	LWB	41.6	47.1	51.7	56.6	42.7	48.5	53.3	58.3	44.4	50.1	55.4	60.7

Rating condition

LEGEND

- BF – Bypass Factor
- CMP – Compressor
- Edb – Entering Dry Bulb
- Ewb – Entering Wet Bulb
- kW – Total Power
- LDB – Leaving Dry Bulb
- LWB – Leaving Wet Bulb
- SHG – Gross Sensible Capacity (1000 Btu/hour)
- TC – Total Net Cooling Capacity (1000 Btu/hour)
- TCG – Gross Cooling Capacity (1000 Btu/hour)

NOTES:

1. Direct interpolation is permissible. Do not extrapolate.
2. The SHG is based on 80°F (26.67°C) edb temperature of air entering indoor coil.
Below 80°F (26.67°C) edb, subtract (corr factor x cfm) from SHG.
Above 80°F (26.67°C) edb, add (corr factor x cfm) to SHG.
Correction Factor = 1.10 x (1 – BF) x (edb – 80).

40KMC, KMQ / 38HDF, QRF

PERFORMANCE DATA (CONT.)

COOLING CAPACITIES HEAT PUMP 38QRF018 WITH 40KMQ01824

Temp °F (°C) Air Entering Condenser (Edb)	Air Entering Evaporator – Cfm/BF												
	445 / 0.05				530 / 0.05				680 / 0.05				
	Air Entering Evaporator – Ewb °F (°C)												
		57 (13.9)	62 (16.7)	67 (19.4)	72 (22.2)	57 (13.9)	62 (16.7)	67 (19.4)	72 (22.2)	57 (13.9)	62 (16.7)	67 (19.4)	72 (22.2)
55 (12.8)	TCG	17.4	18.4	20.2	21.7	18.1	19.1	20.9	22.4	19.9	20.2	21.8	23.2
	SHG	16.6	14.9	13.2	10.9	18.1	15.9	13.8	11.5	19.9	17.7	15.1	12.2
	TC	17.2	18.2	20.0	21.5	17.8	18.7	20.6	22.1	19.5	19.8	21.3	22.8
	kW	1.00	0.99	0.99	1.00	0.99	1.00	1.00	1.00	0.99	1.00	1.00	1.00
	CMP	0.79	0.78	0.78	0.79	0.76	0.77	0.77	0.77	0.73	0.74	0.74	0.74
	LDB	46.4	50.1	53.9	59.0	49.3	53.3	57.2	61.5	53.7	56.8	60.7	64.7
65 (18.3)	LWB	41.2	47.0	52.2	57.9	43.5	49.3	54.5	60.1	45.7	51.8	57.1	62.7
	TCG	16.9	17.8	19.4	21.2	17.6	18.5	20.3	21.8	19.2	19.8	21.1	22.7
	SHG	16.2	14.7	12.6	10.7	17.6	15.6	13.6	11.3	19.2	18.7	14.9	12.2
	TC	16.6	17.5	19.2	20.9	17.3	18.1	19.9	21.5	18.8	19.3	20.6	22.2
	kW	1.11	1.11	1.12	1.12	1.11	1.12	1.12	1.12	1.11	1.11	1.12	1.12
	CMP	0.90	0.90	0.91	0.91	0.88	0.89	0.89	0.89	0.85	0.85	0.86	0.86
75 (23.9)	LDB	47.1	50.5	55.1	59.4	50.1	53.8	57.5	61.8	54.7	55.6	60.9	64.8
	LWB	41.8	47.6	52.9	58.3	43.9	49.7	54.9	60.4	46.2	52.0	57.5	62.9
	TCG	16.0	17.2	18.8	20.6	17.2	17.9	19.5	21.1	18.5	18.9	20.5	21.9
	SHG	16.0	14.7	12.5	10.4	17.2	15.9	13.3	11.0	18.5	18.0	15.1	11.9
	TC	15.8	16.9	18.6	20.3	16.8	17.5	19.2	20.8	18.1	18.5	20.1	21.5
	kW	1.23	1.24	1.25	1.25	1.25	1.25	1.25	1.25	1.24	1.24	1.25	1.25
85 (29.4)	CMP	1.02	1.03	1.04	1.04	1.02	1.02	1.02	1.02	0.98	0.98	0.99	0.99
	LDB	47.5	50.5	55.3	59.9	50.9	53.2	58.1	62.3	55.7	56.5	60.6	65.2
	LWB	42.7	48.2	53.4	58.8	44.3	50.2	55.4	60.9	46.6	52.5	57.8	63.2
	TCG	15.4	16.3	17.9	19.7	16.4	17.0	18.7	20.4	17.8	18.2	19.6	21.1
	SHG	15.4	14.4	12.2	10.0	16.4	15.8	13.2	10.7	17.8	17.0	14.7	11.7
	TC	15.2	16.1	17.7	19.4	16.1	16.7	18.4	20.1	17.4	17.8	19.2	20.7
95 (35.0)	kW	1.38	1.39	1.39	1.40	1.38	1.39	1.39	1.40	1.39	1.39	1.39	1.40
	CMP	1.17	1.18	1.18	1.19	1.15	1.16	1.16	1.17	1.13	1.13	1.13	1.14
	LDB	48.8	51.1	55.9	60.8	52.2	53.4	58.2	62.7	56.6	57.8	61.1	65.4
	LWB	43.3	49.0	54.1	59.4	45.0	50.8	55.9	61.3	47.1	52.9	58.2	63.6
	TCG	14.7	15.3	17.1	18.8	15.7	16.1	17.7	19.5	17.0	17.3	18.3	20.2
	SHG	14.7	14.0	11.9	9.9	15.7	15.3	12.9	10.6	17.0	16.3	14.5	11.3
105 (40.6)	TC	14.4	15.1	16.8	18.6	15.4	15.8	17.4	19.2	16.6	16.9	17.9	19.8
	kW	1.52	1.54	1.55	1.55	1.54	1.54	1.55	1.55	1.55	1.55	1.63	1.64
	CMP	1.31	1.33	1.34	1.34	1.31	1.31	1.32	1.32	1.29	1.29	1.37	1.38
	LDB	50.2	51.9	56.5	60.9	53.5	54.2	58.7	62.8	57.6	58.7	61.7	65.9
	LWB	44.0	49.8	54.8	60.1	45.6	51.5	56.6	61.8	47.5	53.4	58.8	64.0
	TCG	13.9	14.3	15.8	17.8	14.8	15.1	16.5	18.4	16.1	16.0	17.3	19.2
115 (46.1)	SHG	13.9	13.6	11.4	9.4	14.8	14.9	12.6	10.1	16.1	16.0	14.1	11.0
	TC	13.7	14.0	15.6	17.5	14.5	14.8	16.2	18.1	15.7	15.6	16.9	18.7
	kW	1.69	1.69	1.72	1.73	1.70	1.70	1.72	1.73	1.72	1.72	1.73	1.73
	CMP	1.48	1.48	1.51	1.52	1.47	1.47	1.49	1.50	1.46	1.46	1.47	1.47
	LDB	51.9	52.7	57.6	61.8	54.9	54.9	59.2	63.8	58.9	59.1	61.9	66.2
	LWB	44.8	50.8	55.8	60.8	46.3	52.2	57.4	62.4	48.1	54.0	59.3	64.5
125 (51.7)	TCG	13.0	13.2	14.6	16.5	13.9	13.8	15.2	17.1	14.9	15.0	15.8	17.8
	SHG	13.0	12.9	11.0	9.0	13.9	13.8	12.1	9.8	14.9	15.0	13.7	10.8
	TC	12.7	12.9	14.3	16.3	13.5	13.5	14.8	16.8	14.5	14.5	15.4	17.4
	kW	1.86	1.87	1.89	1.92	1.88	1.88	1.90	1.92	1.90	1.90	1.91	1.92
	CMP	1.65	1.66	1.68	1.71	1.65	1.65	1.67	1.69	1.64	1.64	1.65	1.66
	LDB	53.8	54.1	58.2	62.7	56.6	56.8	60.1	64.2	60.4	60.5	62.3	66.5
125 (51.7)	LWB	45.7	51.8	56.8	61.7	47.1	53.1	58.3	63.2	48.8	54.6	60.0	65.0
	TCG	11.9	11.9	13.1	15.1	12.8	12.7	13.7	15.6	13.8	13.8	14.5	16.2
	SHG	11.9	11.9	10.5	8.5	12.8	12.7	11.5	9.2	13.8	13.8	13.1	10.3
	TC	11.7	11.6	12.9	14.9	12.4	12.4	13.4	15.3	13.4	13.4	14.1	15.7
	kW	2.05	2.06	2.08	2.11	2.07	2.07	2.09	2.11	2.09	2.09	2.10	2.12
	CMP	1.84	1.85	1.87	1.90	1.84	1.84	1.86	1.88	1.83	1.83	1.84	1.86
125 (51.7)	LDB	56.0	56.1	59.2	63.6	58.5	58.6	60.9	65.2	61.9	62.1	63.2	67.1
	LWB	46.8	52.0	58.0	62.7	47.9	53.1	59.2	64.1	49.5	55.3	60.7	65.7

Rating condition
Not recommended for long-term operation.

LEGEND

- BF – Bypass Factor
- CMP – Compressor
- Edb – Entering Dry Bulb
- Ewb – Entering Wet Bulb
- kW – Total Power
- LDB – Leaving Dry Bulb
- LWB – Leaving Wet Bulb
- SHG – Gross Sensible Capacity (1000 Btu/hour)
- TC – Total Net Cooling Capacity (1000 Btu/hour)
- TCG – Gross Cooling Capacity (1000 Btu/hour)

NOTES:

1. Direct interpolation is permissible. Do not extrapolate.
2. The SHG is based on 80°F (26.67°C) edb temperature of air entering indoor coil.
Below 80°F (26.67°C) edb, subtract (corr factor x cfm) from SHG.
Above 80°F (26.67°C) edb, add (corr factor x cfm) to SHG.
Correction Factor = 1.10 x (1 – BF) x (edb – 80).

PERFORMANCE DATA (CONT.)

COOLING CAPACITIES HEAT PUMP 38QRF024 WITH 40KMQ01824

Temp °F (°C) Air Entering Condenser (Edb)	Air Entering Evaporator – Cfm/BF												
	445 / 0.05				530 / 0.05				680 / 0.05				
	Air Entering Evaporator – Ewb °F (°C)												
	57 (13.9)	62 (16.7)	67 (19.4)	72 (22.2)	57 (13.9)	62 (16.7)	67 (19.4)	72 (22.2)	57 (13.9)	62 (16.7)	67 (19.4)	72 (22.2)	
55 (12.8)	TCG	20.3	22.1	23.8	26.0	21.3	23.3	25.9	27.0	23.4	24.6	26.6	27.9
	SHG	19.6	17.4	15.1	12.8	21.3	19.0	16.7	13.6	23.4	20.9	17.5	14.4
	TC	20.0	21.8	23.5	25.7	21.0	23.0	25.5	26.7	23.0	24.2	26.1	27.5
	kW	1.17	1.18	1.18	1.21	1.18	1.18	1.19	1.19	1.18	1.19	1.21	1.19
	CMP	0.96	0.97	0.97	1.00	0.95	0.95	0.96	0.96	0.92	0.93	0.95	0.93
	LDB	40.2	45.0	50.2	55.1	43.7	48.0	52.3	57.9	49.0	52.7	57.5	62.0
65 (18.3)	TCG	19.7	21.5	23.5	25.9	20.9	22.6	24.5	26.7	22.7	23.9	26.4	27.7
	SHG	19.2	17.3	15.0	13.0	20.9	18.8	15.8	13.4	22.7	21.0	18.1	14.3
	TC	19.4	21.3	23.3	25.7	20.6	22.3	24.2	26.4	22.3	23.5	25.9	27.2
	kW	1.32	1.33	1.34	1.35	1.33	1.34	1.35	1.36	1.34	1.34	1.35	1.37
	CMP	1.11	1.12	1.13	1.14	1.10	1.11	1.12	1.13	1.08	1.08	1.09	1.11
	LDB	41.1	45.3	50.3	54.8	44.4	48.4	53.8	58.3	49.9	52.5	56.7	62.1
75 (23.9)	TCG	18.8	20.7	22.9	25.1	20.2	21.8	24.0	25.9	22.1	23.2	25.3	27.1
	SHG	18.8	16.8	14.7	12.5	20.2	18.5	16.1	13.1	22.1	21.0	17.5	14.1
	TC	18.6	20.4	22.6	24.8	19.8	21.5	23.6	25.6	21.6	22.7	24.8	26.7
	kW	1.48	1.50	1.51	1.52	1.49	1.51	1.51	1.52	1.50	1.51	1.52	1.53
	CMP	1.27	1.29	1.30	1.31	1.26	1.28	1.28	1.29	1.24	1.25	1.26	1.27
	LDB	41.7	46.1	50.9	55.8	45.7	48.8	53.4	58.8	50.8	52.5	57.4	62.3
85 (29.4)	TCG	18.2	19.8	21.8	23.8	19.5	20.8	23.0	25.0	21.3	22.1	24.3	26.2
	SHG	18.2	16.5	14.3	11.8	19.5	18.1	15.6	12.7	21.3	20.8	17.2	13.8
	TC	17.9	19.5	21.6	23.6	19.2	20.5	22.6	24.7	20.9	21.7	23.8	25.8
	kW	1.66	1.68	1.70	1.71	1.67	1.69	1.70	1.71	1.69	1.70	1.70	1.71
	CMP	1.45	1.47	1.49	1.50	1.44	1.46	1.47	1.48	1.43	1.44	1.44	1.45
	LDB	43.1	46.9	51.7	57.1	46.8	49.5	54.2	59.4	51.9	52.8	57.8	62.6
95 (35.0)	TCG	17.4	18.8	20.8	22.9	18.7	19.7	21.9	24.2	20.4	21.0	23.0	25.1
	SHG	17.4	16.1	13.8	11.5	18.7	17.7	15.1	12.4	20.4	20.3	16.7	13.4
	TC	17.2	18.5	20.6	22.6	18.4	19.4	21.5	23.9	20.0	20.6	22.6	24.7
	kW	1.85	1.87	1.90	1.91	1.87	1.88	1.90	1.91	1.89	1.90	2.05	2.06
	CMP	1.64	1.66	1.69	1.70	1.64	1.65	1.67	1.68	1.63	1.64	1.79	1.80
	LDB	44.7	47.7	52.6	57.8	48.2	50.2	55.0	59.9	53.1	53.4	58.4	63.1
105 (40.6)	TCG	16.6	17.6	19.6	21.9	17.8	18.4	20.7	22.9	19.5	19.6	21.8	23.7
	SHG	16.6	15.6	13.4	11.1	17.8	17.2	14.6	12.0	19.5	19.6	16.9	13.1
	TC	16.3	17.4	19.4	21.6	17.5	18.1	20.3	22.6	19.0	19.2	21.4	23.3
	kW	2.06	2.08	2.11	2.12	2.08	2.09	2.12	2.13	2.11	2.11	2.12	2.13
	CMP	1.85	1.87	1.90	1.91	1.85	1.86	1.89	1.90	1.85	1.85	1.86	1.87
	LDB	46.4	48.7	53.6	58.6	49.8	51.1	55.8	60.7	54.3	54.3	58.2	63.5
115 (46.1)	TCG	15.6	16.3	18.3	20.6	16.8	17.1	19.2	21.3	18.4	18.5	20.1	22.4
	SHG	15.6	15.0	12.8	10.8	16.8	16.6	14.1	11.3	18.4	18.4	15.9	12.5
	TC	15.4	16.0	18.0	20.3	16.5	16.7	18.9	21.0	17.9	18.0	19.7	22.0
	kW	2.28	2.30	2.34	2.36	2.30	2.31	2.35	2.36	2.34	2.34	2.36	2.36
	CMP	2.07	2.09	2.13	2.15	2.07	2.08	2.12	2.13	2.08	2.08	2.10	2.10
	LDB	48.3	49.9	54.6	59.2	51.5	52.0	56.7	61.7	55.8	55.8	59.4	64.3
125 (51.7)	TCG	14.5	14.7	16.8	19.0	15.7	15.7	17.5	19.7	17.1	17.1	18.5	20.7
	SHG	14.5	14.4	12.3	10.1	15.7	15.7	13.5	10.8	17.1	17.1	15.4	11.9
	TC	14.3	14.5	16.6	18.8	15.3	15.4	17.2	19.4	16.7	16.7	18.1	20.3
	kW	2.52	2.53	2.58	2.60	2.55	2.55	2.59	2.60	2.58	2.58	2.60	2.61
	CMP	2.31	2.32	2.37	2.39	2.32	2.32	2.36	2.37	2.32	2.32	2.34	2.35
	LDB	50.6	51.1	55.7	60.4	53.5	53.5	57.7	62.6	57.5	57.6	60.2	65.0
	LWB	44.2	50.4	55.1	59.9	45.6	51.8	56.8	61.7	47.5	53.5	58.7	63.8

Rating condition
Not recommended for long-term operation.

LEGEND

BF – Bypass Factor
 CMP – Compressor
 Edb – Entering Dry Bulb
 Ewb – Entering Wet Bulb
 kW – Total Power
 LDB – Leaving Dry Bulb
 LWB – Leaving Wet Bulb
 SHG – Gross Sensible Capacity (1000 Btu/hour)
 TC – Total Net Cooling Capacity (1000 Btu/hour)
 TCG – Gross Cooling Capacity (1000 Btu/hour)

NOTES:

- Direct interpolation is permissible. Do not extrapolate.
- The SHG is based on 80°F (26.67°C) edb temperature of air entering indoor coil.
 Below 80°F (26.67°C) edb, subtract (corr factor x cfm) from SHG.
 Above 80°F (26.67°C) edb, add (corr factor x cfm) to SHG.
 Correction Factor = 1.10 x (1 – BF) x (edb – 80).

40KMC, KMQ / 38HDF, QRF

PERFORMANCE DATA (CONT.)

COOLING CAPACITIES HEAT PUMP 38QRF030 WITH 40KMQ03036

Temp °F (°C) Air Entering Condenser (Edb)	Air Entering Evaporator – Cfm/BF												
	635 / 0.05				720/0.05				875/0.05				
	Air Entering Evaporator – Ewb °F (°C)												
	57 (13.9)	62 (16.7)	67 (19.4)	72 (22.2)	57 (13.9)	62 (16.7)	67 (19.4)	72 (22.2)	57 (13.9)	62 (16.7)	67 (19.4)	72 (22.2)	
55 (12.8)	TCG	27.9	30.4	32.9	35.0	29.2	31.4	33.8	35.8	31.0	32.8	34.9	36.6
	SHG	26.6	24.1	20.9	17.5	27.6	25.6	21.9	18.2	31.0	28.1	23.4	19.1
	TC	27.4	29.9	32.4	34.5	28.6	30.8	33.2	35.2	30.3	32.0	34.1	35.9
	kW	1.63	1.63	1.64	1.65	1.63	1.64	1.65	1.65	1.64	1.64	1.65	1.65
	CMP	1.20	1.21	1.22	1.23	1.17	1.18	1.19	1.19	1.14	1.14	1.15	1.15
	LDB	42.4	46.2	51.2	56.5	45.6	48.4	53.4	58.5	48.3	51.6	56.8	61.5
65 (18.3)	LWB	39.0	44.3	49.8	55.8	40.7	46.2	51.7	57.7	43.1	48.8	54.4	60.3
	TCG	27.3	29.5	32.2	34.7	28.3	30.5	33.2	35.5	30.4	31.9	34.4	36.3
	SHG	26.0	23.8	20.7	17.3	28.3	25.4	21.8	18.0	30.4	28.1	23.6	18.9
	TC	26.8	29.0	31.7	34.2	27.7	29.9	32.6	34.9	29.7	31.2	33.6	35.6
	kW	1.81	1.82	1.82	1.84	1.81	1.82	1.83	1.84	1.82	1.82	1.83	1.84
	CMP	1.39	1.39	1.40	1.41	1.35	1.36	1.37	1.38	1.32	1.32	1.33	1.34
75 (23.9)	LDB	43.2	46.7	51.5	56.6	44.7	48.7	53.6	58.7	48.9	51.6	56.6	61.7
	LWB	39.5	44.9	50.3	55.9	41.2	46.7	52.1	57.8	43.4	49.1	54.6	60.4
	TCG	26.2	28.6	31.1	34.0	27.6	29.3	32.1	34.8	29.6	30.7	33.5	35.9
	SHG	26.2	23.2	20.2	17.1	27.6	24.9	21.5	17.8	29.6	27.6	23.4	18.9
	TC	25.7	28.1	30.6	33.5	26.9	28.7	31.5	34.2	28.8	29.9	32.7	35.1
	kW	2.01	2.02	2.03	2.04	2.02	2.02	2.03	2.04	2.02	2.03	2.04	2.05
85 (29.4)	CMP	1.59	1.60	1.60	1.61	1.56	1.56	1.57	1.58	1.52	1.53	1.54	1.55
	LDB	43.0	47.6	52.2	57.0	45.7	49.3	54.0	59.0	49.8	52.1	56.7	61.7
	LWB	40.3	45.6	50.9	56.3	41.7	47.4	52.6	58.1	43.8	49.7	55.0	60.6
	TCG	25.1	27.1	29.8	32.8	26.5	28.0	30.8	33.7	28.5	29.3	32.1	34.9
	SHG	25.1	22.9	19.7	16.6	26.5	24.6	21.0	17.4	28.5	27.0	23.0	18.7
	TC	24.6	26.6	29.3	32.3	25.9	27.4	30.2	33.1	27.8	28.5	31.3	34.1
95 (35.0)	kW	2.24	2.25	2.26	2.27	2.24	2.25	2.26	2.27	2.25	2.25	2.26	2.28
	CMP	1.81	1.82	1.83	1.85	1.78	1.79	1.80	1.81	1.75	1.75	1.76	1.78
	LDB	44.4	47.9	52.9	57.7	47.1	49.7	54.6	59.5	50.9	52.7	57.2	62.0
	LWB	41.1	46.6	51.7	57.0	42.4	48.2	53.3	58.7	44.3	50.4	55.6	60.9
	TCG	24.0	25.5	28.3	31.3	25.3	26.4	29.2	32.2	27.2	27.8	30.0	33.3
	SHG	24.0	22.2	19.2	16.0	25.3	23.8	20.4	16.8	27.2	26.4	21.8	18.1
105 (40.6)	TC	23.5	25.0	27.8	30.8	24.7	25.8	28.6	31.6	26.5	27.0	29.2	32.6
	kW	2.47	2.49	2.51	2.52	2.49	2.49	2.51	2.53	2.50	2.50	2.65	2.66
	CMP	2.04	2.06	2.08	2.10	2.03	2.03	2.05	2.07	2.00	2.00	2.15	2.16
	LDB	46.1	48.9	53.6	58.5	48.6	50.6	55.4	60.1	52.3	53.3	57.8	62.5
	LWB	41.9	47.6	52.6	57.8	43.2	49.1	54.1	59.3	45.0	51.0	56.3	61.5
	TCG	22.7	23.8	26.6	29.5	24.0	24.7	27.4	30.5	25.8	26.3	28.6	31.6
115 (46.1)	SHG	22.7	21.4	18.4	15.3	24.0	23.0	19.7	16.2	25.8	24.9	21.8	17.6
	TC	22.2	23.3	26.1	29.1	23.4	24.0	26.8	29.9	25.0	25.6	27.8	30.8
	kW	2.72	2.73	2.77	2.79	2.73	2.75	2.78	2.80	2.76	2.77	2.79	2.81
	CMP	2.29	2.31	2.35	2.37	2.27	2.29	2.32	2.34	2.26	2.27	2.29	2.31
	LDB	47.9	50.0	54.6	59.5	50.3	51.6	56.2	61.0	53.8	54.8	58.4	63.0
	LWB	42.9	48.7	53.6	58.7	44.0	50.0	55.1	60.1	45.7	51.7	57.0	62.1
125 (51.7)	TCG	21.3	22.0	24.6	27.6	22.5	22.9	25.4	28.4	24.2	24.2	26.4	29.4
	SHG	21.3	20.5	17.6	14.6	22.5	21.9	18.9	15.5	24.2	24.2	21.0	16.8
	TC	20.8	21.5	24.1	27.1	21.9	22.3	24.8	27.8	23.5	23.5	25.7	28.7
	kW	2.99	3.00	3.05	3.09	3.01	3.01	3.06	3.10	3.03	3.03	3.07	3.10
	CMP	2.56	2.57	2.62	2.66	2.55	2.55	2.60	2.64	2.53	2.53	2.57	2.60
	LDB	49.9	51.2	55.7	60.4	52.1	53.1	57.2	61.8	55.4	55.5	59.2	63.8
125 (51.7)	LWB	43.9	49.9	54.8	59.7	44.9	51.0	56.1	61.0	46.5	52.6	57.8	62.9
	TCG	19.8	20.2	22.4	25.4	20.9	20.9	23.1	26.1	22.5	22.5	24.1	27.1
	SHG	19.8	19.3	16.8	13.8	20.9	20.9	18.0	14.6	22.5	22.5	20.1	16.0
	TC	19.3	19.7	21.9	24.9	20.3	20.3	22.5	25.5	21.7	21.7	23.3	26.3
	kW	3.28	3.29	3.33	3.40	3.30	3.30	3.35	3.41	3.33	3.33	3.37	3.42
	CMP	2.85	2.86	2.91	2.97	2.84	2.84	2.89	2.95	2.83	2.83	2.87	2.92
125 (51.7)	LDB	52.1	53.0	57.0	61.5	54.2	54.3	58.2	62.8	57.3	57.3	60.1	64.6
	LWB	44.9	51.0	56.0	60.9	45.9	52.1	57.2	62.1	47.4	53.4	58.7	63.7

Rating condition
Not recommended for long-term operation.

LEGEND

BF – Bypass Factor
 CMP – Compressor
 Edb – Entering Dry Bulb
 Ewb – Entering Wet Bulb
 kW – Total Power
 LDB – Leaving Dry Bulb
 LWB – Leaving Wet Bulb
 SHG – Gross Sensible Capacity (1000 Btu/hour)
 TC – Total Net Cooling Capacity (1000 Btu/hour)
 TCG – Gross Cooling Capacity (1000 Btu/hour)

NOTES:

- Direct interpolation is permissible. Do not extrapolate.
- The SHG is based on 80°F (26.67°C) edb temperature of air entering indoor coil.
 Below 80°F (26.67°C) edb, subtract (corr factor x cfm) from SHG.
 Above 80°F (26.67°C) edb, add (corr factor x cfm) to SHG.
 Correction Factor = 1.10 x (1 – BF) x (edb – 80).

PERFORMANCE DATA (CONT.)

COOLING CAPACITIES HEAT PUMP 38QRF035 WITH 40KMQ03036

Temp °F (°C) Air Entering Condenser (Edb)	Air Entering Evaporator – Cfm/BF												
	635 / 0.05				720/0.05				875/0.05				
	Air Entering Evaporator – Ewb (°F)												
	57 (13.9)	62 (16.7)	67 (19.4)	72 (22.2)	57 (13.9)	62 (16.7)	67 (19.4)	72 (22.2)	57 (13.9)	62 (16.7)	67 (19.4)	72 (22.2)	
55 (12.8)	TCG	31.5	34.4	37.4	40.6	32.8	35.7	38.9	41.8	35.1	37.6	40.6	43.0
	SHG	29.3	26.3	23.1	19.9	31.1	28.0	24.5	20.7	33.1	30.7	26.4	21.7
	TC	31.0	33.9	36.9	40.1	32.2	35.1	38.3	41.1	34.3	36.9	39.8	42.3
	kW	1.90	1.90	1.91	1.93	1.90	1.91	1.92	1.93	1.91	1.91	1.93	1.94
	CMP	1.47	1.48	1.49	1.50	1.44	1.45	1.46	1.47	1.41	1.41	1.43	1.44
	LDB	38.5	43.2	48.0	53.0	41.3	45.5	50.3	55.5	46.1	48.9	53.8	58.9
65 (18.3)	LWB	36.2	41.4	46.9	52.5	38.2	43.5	48.9	54.8	40.9	46.4	52.0	57.9
	TCG	30.6	33.3	36.4	39.6	31.8	34.6	37.7	40.9	33.9	36.4	39.4	42.4
	SHG	29.0	25.8	22.7	19.5	30.4	27.5	24.0	20.3	33.9	30.2	25.9	21.5
	TC	30.1	32.8	35.9	39.1	31.2	34.0	37.1	40.2	33.2	35.6	38.7	41.6
	kW	2.12	2.13	2.14	2.16	2.12	2.14	2.15	2.16	2.13	2.14	2.15	2.17
	CMP	1.70	1.71	1.72	1.73	1.66	1.68	1.69	1.70	1.63	1.64	1.65	1.67
75 (23.9)	LDB	38.8	43.8	48.7	53.7	42.1	46.1	50.9	55.9	45.3	49.4	54.2	59.1
	LWB	36.9	42.2	47.6	53.1	38.9	44.2	49.6	55.2	41.5	47.0	52.5	58.1
	TCG	29.3	32.1	35.2	38.4	30.5	33.2	36.4	39.6	33.0	35.0	38.1	41.0
	SHG	28.2	25.3	22.1	18.9	30.5	26.9	23.4	19.8	33.0	29.8	25.5	21.0
	TC	28.8	31.6	34.7	37.9	29.9	32.6	35.8	39.0	32.2	34.2	37.3	40.3
	kW	2.37	2.38	2.40	2.41	2.37	2.39	2.40	2.42	2.38	2.39	2.41	2.42
85 (29.4)	CMP	1.94	1.96	1.97	1.99	1.91	1.93	1.94	1.96	1.88	1.89	1.91	1.92
	LDB	40.0	44.5	49.5	54.4	42.0	46.8	51.6	56.6	46.3	49.8	54.7	59.6
	LWB	37.9	43.1	48.4	53.8	39.8	45.1	50.3	55.8	42.0	47.7	53.1	58.6
	TCG	27.7	30.5	33.7	37.0	29.2	31.7	34.9	38.2	31.6	33.2	36.5	39.6
	SHG	27.5	24.6	21.5	18.3	29.2	26.4	22.8	19.2	31.6	29.2	24.9	20.5
	TC	27.2	30.0	33.2	36.5	28.6	31.0	34.3	37.6	30.8	32.5	35.8	38.9
95 (35.0)	kW	2.62	2.65	2.67	2.69	2.64	2.66	2.68	2.70	2.66	2.67	2.69	2.71
	CMP	2.19	2.23	2.25	2.27	2.18	2.20	2.22	2.24	2.16	2.17	2.19	2.21
	LDB	41.0	45.5	50.4	55.3	43.6	47.5	52.4	57.3	47.7	50.4	55.2	60.1
	LWB	39.2	44.2	49.3	54.6	40.7	46.0	51.1	56.5	42.8	48.5	53.7	59.2
	TCG	26.2	28.6	31.9	35.4	27.8	29.7	33.0	36.5	30.1	31.3	34.2	37.9
	SHG	26.2	23.7	20.8	17.6	27.8	25.5	22.1	18.5	30.1	28.4	23.8	19.9
105 (40.6)	TC	25.7	28.1	31.4	34.9	27.2	29.1	32.4	35.9	29.3	30.5	33.4	37.2
	kW	2.90	2.93	2.98	3.00	2.92	2.95	2.98	3.00	2.95	2.97	3.03	3.05
	CMP	2.47	2.51	2.55	2.57	2.46	2.49	2.52	2.54	2.45	2.47	2.53	2.55
	LDB	42.8	46.7	51.4	56.3	45.4	48.6	53.3	58.1	49.3	51.3	56.1	60.7
	LWB	40.3	45.5	50.4	55.6	41.6	47.1	52.1	57.3	43.6	49.5	54.6	59.8
	TCG	24.7	26.6	29.8	33.2	26.2	27.6	30.9	34.4	28.4	29.0	32.3	35.9
115 (46.1)	SHG	24.7	22.8	19.9	16.8	26.2	24.5	21.2	17.7	28.4	27.4	23.4	19.2
	TC	24.2	26.1	29.3	32.8	25.6	27.0	30.2	33.8	27.6	28.3	31.6	35.1
	kW	3.20	3.23	3.29	3.32	3.22	3.25	3.30	3.33	3.26	3.27	3.32	3.34
	CMP	2.78	2.81	2.87	2.84	2.76	2.79	2.84	2.87	2.76	2.77	2.82	2.84
	LDB	45.0	48.1	52.6	57.3	47.5	49.8	54.3	59.1	51.1	52.3	56.8	61.5
	LWB	41.4	46.9	51.7	56.6	42.6	48.4	53.3	58.3	44.4	50.5	55.5	60.6
125 (51.7)	TCG	23.0	24.3	27.5	31.0	24.4	25.3	28.4	32.0	26.5	27.0	29.7	33.4
	SHG	23.0	21.7	18.9	15.9	24.4	23.4	20.2	16.8	26.5	25.7	22.4	18.2
	TC	22.5	23.8	27.0	30.5	23.8	24.6	27.8	31.4	25.7	26.3	29.0	32.6
	kW	3.53	3.55	3.61	3.68	3.55	3.57	3.63	3.69	3.59	3.60	3.66	3.70
	CMP	3.10	3.13	3.19	3.26	3.09	3.11	3.17	3.23	3.09	3.10	3.16	3.20
	LDB	47.5	49.6	54.0	58.6	49.7	51.2	55.6	60.2	53.1	54.0	57.8	62.4
125 (51.7)	LWB	42.6	48.4	53.1	58.0	43.8	49.7	54.6	59.4	45.4	51.4	56.5	61.5
	TCG	21.2	21.8	24.8	28.3	22.5	23.0	25.7	29.2	24.4	24.4	26.9	30.5
	SHG	21.2	20.6	17.8	14.9	22.5	21.9	19.1	15.8	24.4	24.4	21.2	17.2
	TC	20.7	21.3	24.4	27.8	21.9	22.4	25.1	28.6	23.6	23.7	26.1	29.8
	kW	3.88	3.90	3.96	4.04	3.91	3.92	3.98	4.06	3.95	3.95	4.00	4.07
	CMP	3.46	3.47	3.54	3.62	3.45	3.46	3.52	3.60	3.45	3.45	3.50	3.57
125 (51.7)	LDB	50.1	51.2	55.5	60.0	52.2	53.0	56.9	61.4	55.2	55.3	58.9	63.3
	LWB	44.0	50.0	54.6	59.4	45.0	51.0	55.9	60.7	46.4	52.5	57.6	62.5

Rating condition
Not recommended for long-term operation.

LEGEND

BF – Bypass Factor
CMP – Compressor
Edb – Entering Dry Bulb
Ewb – Entering Wet Bulb
kW – Total Power
LDB – Leaving Dry Bulb
LWB – Leaving Wet Bulb
SHG – Gross Sensible Capacity (1000 Btu/hour)
TC – Total Net Cooling Capacity (1000 Btu/hour)
TCG – Gross Cooling Capacity (1000 Btu/hour)

NOTES:

- Direct interpolation is permissible. Do not extrapolate.
- The SHG is based on 80°F (26.67°C) edb temperature of air entering indoor coil.
Below 80°F (26.67°C) edb, subtract (corr factor x cfm) from SHG.
Above 80°F (26.67°C) edb, add (corr factor x cfm) to SHG.
Correction Factor = 1.10 x (1 – BF) x (edb – 80).

40KMC, KMQ / 38HDF, QRF

PERFORMANCE DATA (CONT.)

**INSTANTANEOUS AND INTEGRATED HEATING RATINGS
40KMQ01824 WITH 38QRF018**

Air Temperature Entering Indoor Unit ° F (° C)	Indoor Airflow (CFM) L-M-H	Item	Air Temperature Entering Outdoor Coil ° F (° C)														
			17 (-8.3)			27 (-2.8)			37 (2.8)			47 (8.3)			57 (13.9)		
			Instant. Rating	Integrated Rating	Cap	Instant. Rating	Integrated Rating	Cap	Instant. Rating	Integrated Rating	Cap	Instant. Rating	Integrated Rating	Cap	Instant. Rating	Integrated Rating	Cap
55 (12.8)	470	Cap kW	10.64	9.70	12.87	1.12	11.25	14.73	13.41	16.75	13.33	19.45	16.75	13.33	19.45	16.75	13.33
		Cap kW	10.82	9.87	12.87	1.10	11.43	14.85	13.52	17.07	1.27	19.86	17.07	1.27	19.86	17.07	1.27
		Cap kW	11.02	10.05	13.10	1.08	11.63	15.04	13.69	17.47	1.20	20.31	17.47	1.20	20.31	17.47	1.20
60 (15.6)	470	Cap kW	10.31	9.40	12.41	1.17	11.02	14.48	13.17	16.61	1.36	19.10	16.61	1.36	19.10	16.61	1.36
		Cap kW	10.52	9.59	12.59	1.16	11.18	14.75	13.42	16.86	1.32	19.54	16.86	1.32	19.54	16.86	1.32
		Cap kW	10.72	9.77	12.82	1.14	11.38	14.92	13.58	17.16	1.28	20.00	17.16	1.28	20.00	17.16	1.28
65 (18.3)	470	Cap kW	9.96	9.08	12.08	1.23	10.73	14.31	13.02	16.42	1.40	18.76	16.42	1.40	18.76	16.42	1.40
		Cap kW	10.08	9.19	12.27	1.22	10.89	14.57	13.26	16.56	1.39	19.18	16.56	1.39	19.18	16.56	1.39
		Cap kW	10.39	9.47	12.51	1.20	11.11	14.80	13.47	16.89	1.34	19.65	16.89	1.34	19.65	16.89	1.34
70 (21.1)	470	Cap kW	9.49	8.66	11.74	1.28	10.43	13.99	12.74	16.26	1.46	18.43	16.26	1.46	18.43	16.26	1.46
		Cap kW	9.75	8.89	11.99	1.26	10.65	14.24	12.96	16.43	1.45	18.84	16.43	1.45	18.84	16.43	1.45
		Cap kW	9.50	8.66	12.25	1.27	10.88	14.54	13.23	16.80	1.44	19.31	16.80	1.44	19.31	16.80	1.44
75 (23.9)	470	Cap kW	9.23	8.42	11.33	1.35	10.06	13.63	12.41	15.90	1.49	18.11	15.90	1.49	18.11	15.90	1.49
		Cap kW	9.37	8.54	11.63	1.32	10.33	13.90	12.65	16.23	1.59	18.50	16.23	1.59	18.50	16.23	1.59
		Cap kW	9.65	8.80	11.87	1.31	10.55	14.19	12.91	16.45	1.44	18.94	16.45	1.44	18.94	16.45	1.44
80 (26.7)	470	Cap kW	8.84	8.06	10.97	1.40	9.75	13.24	12.05	15.65	1.55	17.87	15.65	1.55	17.87	15.65	1.55
		Cap kW	9.05	8.25	11.24	1.39	9.98	13.55	12.33	15.98	1.51	18.18	15.98	1.51	18.18	15.98	1.51
		Cap kW	9.26	8.44	11.51	1.37	10.22	13.85	12.60	16.23	1.48	18.60	16.23	1.48	18.60	16.23	1.48

Indicates Rating Condition (*Integrated Capacity)

Indicates Integrated Rating

Cap – Heating Capacity (100 Btuh), Includes indoor fan motor heat

kW – Total Power Input, includes compressor motor power input, outdoor fan motor power input, and indoor fan motor power input

Note: Integrated Capacity is maximum (instantaneous) capacity less the effect of frost on the outdoor coil and the heat to defrost it.

PERFORMANCE DATA (CONT.)

INSTANTANEOUS AND INTEGRATED HEATING RATINGS 40KMQ024 HIGH WALL 38QRF024

Air Temperature Entering Indoor Unit °F (°C)	Indoor Airflow (CFM) L-M-H	Item	Air Temperature Entering Outdoor Coil °F (°C)														
			17 (-8.3)			27 (-2.8)			37 (2.8)			47 (8.3)			57 (13.9)		
			Instant. Rating	Integrated Rating	Instant. Rating	Integrated Rating	Instant. Rating	Integrated Rating	Instant. Rating	Integrated Rating	Instant. Rating	Integrated Rating	Instant. Rating	Integrated Rating			
55 (12.8)	470	Cap	13.69	12.48	16.26	14.44	18.71	17.02	21.47	21.47	21.47	21.47	24.22	24.22			
		KW	1.50	1.67	1.82	1.82	2.13	2.13	2.44	2.44	2.44	2.44	2.44				
		Cap	14.10	12.86	16.61	14.75	19.19	17.46	22.02	22.02	22.02	22.02	24.99	24.99			
560	560	KW	1.47	1.61	1.77	1.77	2.00	2.00	2.24	2.24	2.24	2.24	2.24				
		Cap	14.10	12.85	16.91	15.02	19.53	17.77	22.39	22.39	22.39	25.39	25.39				
		KW	1.45	1.55	1.69	1.69	1.87	1.87	2.01	2.01	2.01	2.01	2.01				
60 (15.6)	470	Cap	13.61	12.41	16.02	14.22	18.56	16.89	21.10	21.10	21.10	23.90	23.90				
		KW	1.55	1.66	1.91	1.91	2.14	2.14	2.42	2.42	2.42	2.42					
		Cap	13.82	12.60	16.26	14.44	18.93	17.23	21.66	21.66	21.66	24.40	24.40				
60 (15.6)	560	KW	1.49	1.64	1.86	1.86	2.07	2.07	2.33	2.33	2.33	2.33					
		Cap	14.09	12.85	16.67	14.81	19.31	17.57	22.10	22.10	22.10	25.01	25.01				
		KW	1.45	1.60	1.78	1.78	1.96	1.96	2.11	2.11	2.11	2.11					
65 (18.3)	470	Cap	13.32	12.15	15.70	13.94	17.79	16.19	20.84	20.84	20.84	23.51	23.51				
		KW	1.59	1.74	1.92	1.92	2.08	2.08	2.20	2.20	2.20	2.52	2.52				
		Cap	13.51	12.32	16.06	14.26	18.64	16.96	21.41	21.41	21.41	24.14	24.14				
65 (18.3)	560	KW	1.57	1.71	1.92	1.92	2.13	2.13	2.41	2.41	2.41	2.41					
		Cap	13.80	12.58	16.24	14.42	19.01	17.30	21.87	21.87	21.87	24.74	24.74				
		KW	1.51	1.66	1.83	1.83	2.05	2.05	2.25	2.25	2.25	2.25					
70 (21.1)	470	Cap	10.80	9.85	15.47	13.74	18.00	16.38	20.56	20.56	20.56	23.18	23.18				
		KW	1.65	1.81	2.05	2.05	2.31	2.31	2.58	2.58	2.58	2.58					
		Cap	11.00	10.03	15.71	13.95	18.28	16.64	20.65	20.65	20.65	23.82	23.82				
70 (21.1)	560	KW	1.65	1.76	1.92	1.92	2.01	2.01	2.23	2.23	2.23	2.52	2.52				
		Cap	11.20	10.21	15.98	14.19	18.71	17.03	20.80	20.80	20.80	24.43	24.43				
		KW	1.64	1.78	1.89	1.89	2.05	2.05	2.35	2.35	2.35	2.35					
75 (23.9)	470	Cap	10.70	9.76	15.00	13.32	17.11	15.57	20.21	20.21	20.21	22.81	22.81				
		KW	1.71	1.89	2.06	2.06	2.42	2.42	2.69	2.69	2.69	2.69					
		Cap	10.90	9.94	15.41	13.68	18.06	16.44	20.60	20.60	20.60	23.45	23.45				
75 (23.9)	560	KW	1.67	1.82	2.01	2.01	2.27	2.27	2.63	2.63	2.63	2.63					
		Cap	11.00	10.03	15.73	13.97	18.43	16.77	20.75	20.75	20.75	24.21	24.21				
		KW	1.64	1.78	1.97	1.97	2.20	2.20	2.45	2.45	2.45	2.45					
80 (26.7)	470	Cap	10.50	9.57	15.09	13.40	17.34	15.78	19.22	19.22	19.22	22.37	22.37				
		KW	1.77	1.93	2.20	2.20	2.37	2.37	2.82	2.82	2.82	2.82					
		Cap	10.70	9.76	15.02	13.34	17.45	15.88	20.36	20.36	20.36	23.14	23.14				
80 (26.7)	560	KW	1.75	1.92	2.15	2.15	2.35	2.35	2.66	2.66	2.66	2.66					
		Cap	10.80	9.85	15.41	13.68	18.06	16.44	20.70	20.70	20.70	23.90	23.90				
		KW	1.72	1.84	2.12	2.12	2.28	2.28	2.56	2.56	2.56	2.56					

Indicates Rating Condition (*Integrated Capacity)

Indicates Integrated Rating

Heating Capacity (100 Btuh), Includes indoor fan motor heat

Note: Total Power Input, includes compressor motor power input, outdoor fan motor power input, and indoor fan motor power input (instantaneous) capacity less the effect of frost on the outdoor coil and the heat to defrost it.

Cap –
kW –

PERFORMANCE DATA (CONT.)

INSTANTANEOUS AND INTEGRATED HEATING RATINGS 40KMQ030 WITH 38QRF030

Air Temperature Entering Indoor Unit °F (°C)	Indoor Airflow (CFM) L-M-H	Item	Air Temperature Entering Outdoor Coil °F (°C)											
			17 (-8.3)		27 (-2.8)		37 (2.8)		47 (8.3)		57 (13.9)			
			Instant. Rating	Integrated Rating	Instant. Rating	Integrated Rating	Instant. Rating	Integrated Rating	Instant. Rating	Integrated Rating	Instant. Rating	Integrated Rating		
55 (12.8)	670	Cap	18.23	16.62	21.04	18.69	24.76	22.54	28.14	28.14	31.61	31.61		
		kW	1.97	2.18	2.35	2.42	2.86	2.86						
		Cap	18.28	16.66	21.67	19.25	25.01	22.76	28.56	28.56	32.46	32.46		
60 (15.6)	670	kW	1.99	2.13	2.23	2.42	2.67	2.67						
		Cap	18.74	17.08	22.20	19.71	25.49	23.20	29.15	29.15	33.59	33.59		
		kW	1.96	2.03	2.24	2.40	2.61	2.61						
60 (15.6)	670	Cap	17.74	16.18	20.67	18.36	24.38	22.19	27.96	27.96	31.66	31.66		
		kW	2.03	2.21	2.36	2.49	2.89	2.89						
		Cap	17.94	16.36	21.16	18.80	24.75	22.53	28.32	28.32	31.87	31.87		
60 (15.6)	670	kW	2.06	2.19	2.34	2.49	2.82	2.82						
		Cap	18.42	16.79	21.43	19.04	24.98	22.73	28.70	28.70	33.17	33.17		
		kW	2.00	2.18	2.27	2.49	2.59	2.59						
60 (15.6)	670	Cap	17.28	15.76	20.19	17.93	23.86	21.71	27.38	27.38	30.59	30.59		
		kW	2.10	2.36	2.46	2.72	3.19	3.19						
		Cap	17.67	16.11	20.56	18.26	24.31	22.12	26.80	26.80	31.89	31.89		
65 (18.3)	670	kW	2.10	2.33	2.43	2.98	2.98							
		Cap	17.92	16.34	21.31	18.93	24.65	22.43	28.27	28.27	32.49	32.49		
		kW	2.10	2.20	2.35	2.59	2.70	2.70						
60 (15.6)	670	Cap	16.40	14.95	20.01	17.77	23.39	21.28	26.86	26.86	30.59	30.59		
		kW	2.29	2.39	2.52	2.85	3.12	3.12						
		Cap	16.50	15.04	20.23	17.96	23.72	21.59	27.17	27.17	31.40	31.40		
70 (21.1)	670	kW	2.28	2.38	2.49	2.81	2.91	2.91						
		Cap	16.60	15.14	20.86	18.53	23.79	21.65	27.40	27.40	32.16	32.16		
		kW	2.27	2.30	2.62	2.80	2.80	2.80						
60 (15.6)	670	Cap	16.30	14.86	19.61	17.42	22.58	20.54	26.40	26.40	30.34	30.34		
		kW	2.30	2.45	2.73	2.89	3.10	3.10						
		Cap	16.40	14.95	19.76	17.55	23.01	20.94	26.73	26.73	30.93	30.93		
75 (23.9)	670	kW	2.29	2.46	2.73	2.80	3.04	3.04						
		Cap	16.55	15.09	20.40	18.12	23.48	21.37	27.31	27.31	31.46	31.46		
		kW	2.28	2.37	2.68	2.84	2.98	2.98						
60 (15.6)	670	Cap	15.77	14.38	19.06	16.93	22.55	20.52	25.80	25.80	29.76	29.76		
		kW	2.33	2.51	2.71	3.01	3.22	3.22						
		Cap	16.21	14.78	19.55	17.36	22.57	20.54	26.26	26.26	30.23	30.23		
80 (26.7)	670	kW	2.30	2.50	2.77	2.89	3.08	3.08						
		Cap	16.50	15.04	19.79	17.58	23.32	21.22	26.72	26.72	30.91	30.91		
		kW	2.30	2.50	2.64	2.97	3.08	3.08						

Indicates Rating Condition (*Integrated Capacity)

Indicates Integrated Rating

Cap – Heating Capacity (100 Btuh), Includes indoor fan motor heat

kW – Total Power Input, includes compressor motor power input, outdoor fan motor power input, and indoor fan motor power input

Note: Integrated Capacity is maximum (instantaneous) capacity less the effect of frost on the outdoor coil and the heat to defrost it.

PERFORMANCE DATA (CONT.)

INSTANTANEOUS AND INTEGRATED HEATING RATINGS 40KMQ36 WITH 388QRF035

Air Temperature Entering Indoor Unit °F (°C)	Indoor Airflow (CFM) L-M-H	Item	Air Temperature Entering Outdoor Coil °F (°C)														
			17 (-8.3)			27 (-2.8)			37 (2.8)			47 (8.3)			57 (13.9)		
			Instant. Rating	Integrated Rating	Instant. Rating	Integrated Rating	Instant. Rating	Integrated Rating	Instant. Rating	Integrated Rating	Instant. Rating	Integrated Rating	Instant. Rating	Integrated Rating			
55 (12.8)	670	Cap	21.30	19.42	22.25	28.90	26.30	33.06	37.62	37.62	37.62	37.62	37.62	37.62	37.62		
		kW	2.23	2.42	2.68	2.90	2.68	2.90	2.90	2.90	2.90	2.90	2.90	2.90			
		Cap	21.66	19.75	22.43	29.24	26.61	33.51	38.40	38.40	38.40	38.40	38.40	38.40			
760	910	kW	2.19	2.40	2.60	2.94	2.60	2.80	3.03	3.03	3.03	3.03	3.03	3.03			
		Cap	22.10	20.15	22.86	29.73	27.05	34.30	39.36	39.36	39.36	39.36	39.36				
		kW	2.15	2.34	2.56	2.93	2.56	2.66	2.90	2.90	2.90	2.90	2.90				
60 (15.6)	670	Cap	20.73	18.90	22.01	28.29	25.75	32.52	37.12	37.12	37.12	37.12	37.12				
		kW	2.33	2.47	2.79	2.89	2.79	3.07	3.33	3.33	3.33	3.33	3.33				
		Cap	21.19	19.32	22.27	28.90	26.29	33.14	37.75	37.75	37.75	37.75	37.75				
760	910	kW	2.28	2.45	2.70	2.93	2.70	2.95	3.19	3.19	3.19	3.19	3.19				
		Cap	21.55	19.65	22.49	29.38	26.73	33.72	38.71	38.71	38.71	38.71	38.71				
		kW	2.26	2.44	2.63	2.93	2.63	2.80	3.06	3.06	3.06	3.06	3.06				
60 (18.3)	670	Cap	20.03	18.26	21.40	28.13	25.60	32.03	36.48	36.48	36.48	36.48	36.48				
		kW	2.44	2.61	2.85	2.85	2.85	3.16	3.52	3.52	3.52	3.52					
		Cap	20.56	18.74	21.85	28.55	25.98	32.69	37.18	37.18	37.18	37.18					
760	910	kW	2.39	2.55	2.79	2.85	2.79	3.03	3.38	3.38	3.38	3.38	3.38				
		Cap	20.97	19.12	22.29	28.81	26.22	33.27	38.19	38.19	38.19	38.19					
		kW	2.36	2.49	2.76	2.81	2.76	2.94	3.15	3.15	3.15	3.15					
70 (21.1)	670	Cap	19.40	17.69	20.78	27.59	25.10	31.48	36.22	36.22	36.22	36.22	36.22				
		kW	2.69	2.70	2.92	2.81	2.92	3.29	3.52	3.52	3.52	3.52					
		Cap	19.50	17.78	21.35	28.13	25.59	32.02	36.73	36.73	36.73	36.73					
760	910	kW	2.68	2.69	2.88	2.81	2.88	3.28	3.44	3.44	3.44	3.44					
		Cap	19.60	17.87	21.85	28.49	25.92	32.40	37.58	37.58	37.58	37.58					
		kW	2.67	2.68	2.84	2.84	2.84	3.27	3.28	3.28	3.28	3.28					
75 (23.9)	670	Cap	18.95	17.28	20.17	27.29	24.83	31.01	35.35	35.35	35.35	35.35					
		kW	2.70	2.83	3.01	2.81	3.01	3.40	3.82	3.82	3.82	3.82					
		Cap	19.14	17.45	20.78	27.63	25.15	31.43	36.06	36.06	36.06	36.06					
80 (26.7)	670	kW	2.69	2.77	2.98	2.84	2.98	3.34	3.67	3.67	3.67	3.67					
		Cap	19.40	17.69	21.27	28.04	25.52	32.33	36.90	36.90	36.90	36.90					
		kW	2.68	2.71	2.94	2.84	2.94	3.28	3.48	3.48	3.48						
760	910	Cap	18.26	16.65	19.71	26.66	24.27	30.58	34.43	34.43	34.43	34.43					
		kW	2.72	2.91	3.14	2.81	3.14	3.51	4.13	4.13	4.13						
		Cap	18.47	16.84	20.11	27.15	24.70	31.11	35.39	35.39	35.39						
80 (26.7)	910	kW	2.71	2.90	3.07	2.81	3.07	3.43	3.87	3.87	3.87	3.87					
		Cap	16.50	15.04	20.84	27.82	25.31	31.79	36.37	36.37	36.37						
		kW	2.69	2.81	3.00	2.81	3.00	3.29	3.66	3.66	3.66						

Indicates Rating Condition (*Integrated Capacity)

Indicates Integrated Rating

Cap – Heating Capacity (100 Btuh), Includes indoor fan motor heat

kW – Total Power Input, includes compressor motor power input, outdoor fan motor power input, and indoor fan motor power input

Note: Integrated Capacity is maximum (instantaneous) capacity less the effect of frost on the outdoor coil and the heat to defrost it.

APPLICATION DATA

UNIT SELECTION

The in-ceiling cassette units are available as cooling only, cooling only with electric heat, or heat pumps with electric heat. For most applications, the cooling load dictates the size selection. Select equipment to either match or be slightly less than anticipated peak load. This provides better humidity control, fewer unit cycles, and better low load performance.

For units used in spaces with high sensible loads, base equipment selection on unit sensible load, not on total anticipated load to avoid oversizing the equipment.

UNIT MOUNTING (INDOOR)

Unit leveling - For reliable operation, units should be level in all planes. Align and level the unit by adjusting the nuts and lock-nuts on the threaded hangers.

Clearance - A minimum of 12 inches (304.8 mm) of clearance is required in the false ceiling.

Unit location - Placing the unit in the center of the room will provide the best air circulation and comfort.

The unit return and discharge should not be obstructed by anything which may cause unit short cycling or air recirculation.

Support - Threaded hangers should be used to install the unit and the structure should provide adequate support for the weight of the unit.

Installation Template - Fan coil units are supplied with a cardboard template to help match the position of the hangers, refrigerant lines, condensate drain pipe and power supply cable.

UNIT MOUNTING (OUTDOOR)

Unit leveling - For reliable operation, units should be level in all planes.

Clearance - Minimum clearance, as shown in Fig. 7, must be provided for airflow. The condensing units are designed for free-blow application. Air inlets and outlets should not be restricted.

Unit location - A location which is convenient to installation and not exposed to strong wind. If unit is exposed to strong winds it is recommended that a wind baffle accessory be used.

A location which can bear the weight of outdoor unit and where the outdoor unit can be mounted in a level position.

Mounting Pad - The minimum mounting pad dimensions are listed in the following table:

UNIT MODEL	MAXIMUM MOUNTING PAD DIMENSIONS ft-in. (mm)
38HDF018, 024, 030 38QRF018, 024	1'-11" X 3'-6" (584.2 X 1066.8)
38HDF036 38QRF030, 036	2'-0" X 4'-2" (609.6 X 1270)

SYSTEMS OPERATING CONDITIONS

Cooling Operating Range

	Maximum		Minimum	
	DB ° F (° C)	WB ° F (° C)	DB ° F (° C)	WB ° F (° C)
Outdoor Unit	125 (51.7)	--	55 (12.8)	--
Indoor Unit	90 (32.2)	74 (23.3)	62 (17.0)	56 (13)

Heating Operating Range

	Maximum		Minimum	
	DB ° F (° C)	WB ° F (° C)	DB ° F (° C)	WB ° F (° C)
Outdoor Unit	75 (23.9)	67 (19.4)	17 (-8.3)	--
Indoor Unit	81 (27.2)	--	62 (17.0)	--

Low Ambient Operation

Both cooling only and heat pumps will operate in cooling down to 55°F (12.8°C).

When equipped with a Low Ambient Controller, the unit will operate down to -20°F (-28.9°C).

For proper operation of cooling only units, a Winter Start Kit (bypasses the Low Pressure Switch), a Crankcase Heater (prevents refrigerant migration during compressor-off cycle), and a Wind Baffle should also be installed.

On heat pumps, a Winter Start Kit will not be required. An Isolation Relay to bypass the Low Ambient Controller when unit is in heating mode will be required.

Metering Devices

An Accurater installed at the outdoor unit is used as a metering device. This requires that both refrigerant lines be insulated. (A heat pump unit has 2 Accurater.)

Drain Connections

The in-ceiling cassette is supplied with a pump that is capable of lifting the water 7.8" (200 mm) above the top of the unit. A downward sloped condensate drain pipe can be used to dispose of water.

REFRIGERANT LINES

General refrigerant line sizing:

1. Refrigerant lines should not be buried in the ground. If it is necessary to bury the lines, not more than 36-in (914 mm) should be buried. Provide a minimum 6-in (152 mm) vertical rise to the service valves to prevent refrigerant migration.
2. Both lines must be insulated. Use a minimum of 1/2-in. (12.7 mm) thick insulation. Closed-cell insulation is recommended in all long-line applications.
3. Special consideration should be given to isolating interconnecting tubing from the building structure. Isolate the tubing so that vibration or noise is not transmitted into the structure.

NOTE: Since the same outdoor unit can be matched with different types of indoor units, it may not have enough refrigerant charge. Refer to the Physical Data tables to determine if additional charge is required.

Long Line Applications

The following table indicates the maximum line lengths that can be used with the high wall systems.

ITEM	MAX LENGTH ALLOWED ft (m)
Total Piping	200 (61)
Max Lift (Fan Coil above)	65 (20)
Max Drop (Fan Coil below)	200 (61)

For line lengths over 25 ft (7.6 m), .3 oz (.009 kg) of charge should be added for each additional foot up to the maximum allowed.

For line lengths over 80 ft (24.4 m), certain accessories and adjustments to the piston sizes are also required.

Refer to the *Duct-Free Split Systems Long Line Guide* for additional information.

CONTROL SYSTEM

The 40KMC,KMQ unit is equipped with a microprocessor controls to operate the system and provide optimum levels of comfort and operating efficiency.

The main microprocessor is located in the control box of the fan coil unit with thermistors located in the fan coil inlet and on the indoor coil. These thermistors monitor the system operation and control the operating mode. To change the settings or the modes of operation, use an accessory wireless remote control, an accessory wired controller, or an accessory Zone Manager.

The 40KMC,KMQ unit has 5 operating modes:

- Fan Only
- Auto (heat pump models only)
- Heating (heat pump models only)
- Cooling
- Dehumidification (Dry)

FAN ONLY - In Fan Only mode, the system filters and circulates the room air without changing the room air temperature.

AUTO - In Auto mode, the system will automatically select one of the following operating modes: cooling, heating or fan only based on the difference between the room temperature and the set point temperature.

HEATING - In the Heating mode, the system heats and filters room air.

COOLING - In Cooling mode, the system cools, dries and filters room air.

DEHUMIDIFICATION (DRY) - in Dehumidification (Dry) mode, the system dries, filters and slightly cools room temperature. This mode does not take the place of a dehumidifier.

In addition to the above modes that are selected by using the user interface accessories, the unit can run in two other modes selected by the manual button:

- EMERGENCY RUN
- TEST MODE

EMERGENCY mode - is used when the remote control is misplaced or the batteries in the remote control have expired. Pushing the EMERGENCY switch under the grille will put the unit in Auto mode with a predetermined set point (73.4°F/ 23°C).

TEST mode - is used when a technician needs to diagnose the unit for a malfunction. The unit can be set into TEST mode using either the remote control or sliding the TEST switch under the grille to the appropriate location. When in TEST mode, the unit will run in cooling for 30 minutes regardless of the set point.

The microprocessor controls offer additional comfort and economy features like SLEEP mode, TIMER and AUTO SWEEP. Refer to the Owner's Manual for additional details on these features.

USER INTERFACE

Depending on the application, a wired or wireless controller can be selected to run the unit.

The wireless remote has a range of 26 ft (8 m) when pointed toward the unit.

For applications that have multiple units, these controls offer additional flexibility

Two Units In the Same Room Controlled by a Wireless Remote

If the two units are working independently, the two remotes can be configured differently so that the signal from one remote does not interfere with the operation of the other units.

Multiple Units Controlled by One Wired Controller

When there is an application where all units require the same setting, up to 6 units can be daisy-chained and controlled by one wired remote control. Total length of connecting wire can be up to 500 ft (152.4 m).

Zoning

For applications that require zoning, the Zone Manager is offered as an accessory. This will allow up to 32 units to be connected in up to 8 zones. Each zone can be programmed for 7 days with each day having 4 periods.

Electric Heat

The 40KMQ has a 3 Kw electric heater factory installed. when the 40KMQ is matched with a heat pump outdoor unit, the electric heater is supplementary.

When the heat generated from the heat pump cannot meet the demands of the load, the electric heater is activated until the set point is satisfied.

When the 40KMQ is matched with a cooling only outdoor unit the electric heater is activated when the system is in heating mode.

Air Distribution

The in-ceiling cassette units are very versatile with many features that make them very flexible.

Cooling an adjacent room - The 40KMC and 40KMQ units are supplied with pre-punched knockouts that can be used to cool and heat an adjacent room. The amount of CFM that can be channeled to an adjacent room is dependent on the amount of static in the field supplied ductwork. Use the chart in Fig. 9 to determine the CFM.

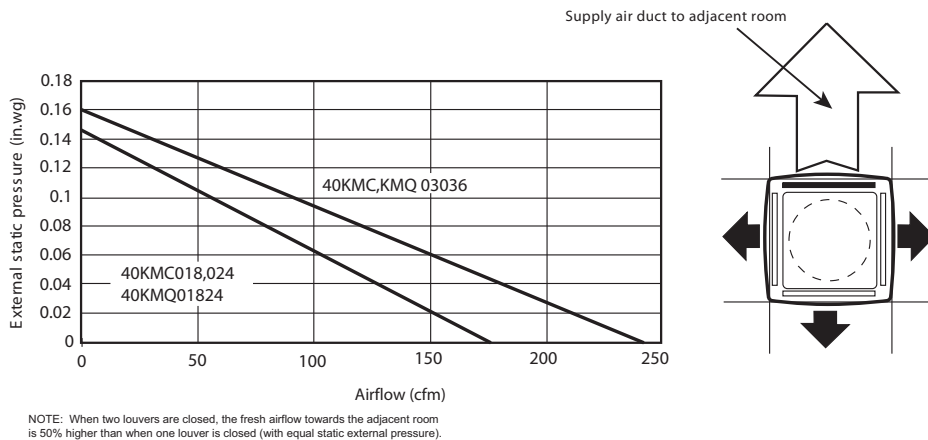

Fig. 9 – Pressure Drop for Conditioned Air Supply to an Adjacent Room: One Louver Closed

Outside Air - Up to 20% outside air can be introduced to the 40KMC or 40KMQ through pre-punched knockouts.

If the 40KMC or 40KMQ is installed close to an outside wall, some outside air can be introduced by running field supplied ductwork to the unit. the amount of outside air that can be introduced is determined by using the chart in Fig. 9.

If the cassette is installed in the middle of a room and is not close to an outside wall, a power ventilation kit can be used to overcome the static pressure in the ductwork and allow the needed CFM. For applications that are very sound sensitive, it is recommended to limit the fresh air intake to 10% when using a power ventilation kit.

Air Discharge - The 40KMC and 40KMQ units have four discharge outlets that are equipped with motorized louvers for better comfort. The user has three operating choices with the louvers

1. **AUTO** - The position of the louver is determined by the mode in which the unit is running.
2. **CONTINUOUS** - Louvers move continuously
3. **STATIONARY** - Louver position is determined by the user.

Air can be discharged from 4, 3, or 2 louvers. An accessory kit is required to block the discharge from each louver.

Air Throw Data - The following table shows the air throw data of the 40KMC and 40KMQ units. The numbers shown indicate the maximum distances reached by the airflow with a speed equal to or greater than .66 ft/sec (0.2 m/sec) with louvers in the cooling position.

AIR THROW DATA*

Model	4 Louvers Open ft (m)	3 Louvers Open ft (m)	2 Louvers Open ft (m)
40KMC018---3	15.75 (4.8)	17.4 (5.3)	19.0 (5.8)
40KMC024---3	9.8 (3.0)	11.5 (3.5)	13.0 (4.0)
40KMC03036---3	14.1 (4.3)	15.75 (4.8)	17.4 (5.3)
40KMQ01824---3	9.8 (3.0)	11.5 (3.5)	13.0 (4.0)
40KMQ03036---3	14.1 (4.3)	15.75 (4.8)	17.4 (5.3)

* High Speed

SOUND RATINGS

Outdoor Units

Model Number	Sound Power dBA	Sound Pressure dBA
38HDF018---3	66	55
38HDF024---3	66	55
38HDF030---3	72	61
38HDF036---3/5/6	72	61
38QRF018---3	66	55
38QRF024---3	66	55
38QRF030---3	72	61
38QRF036---3/5/6	72	61

Indoor Units

Model Number	High		Medium		Low	
	Sound Power dBA	Sound Pressure dBA	Sound Power dBA	Sound Pressure dBA	Sound Power dBA	Sound Pressure dBA
40KMC018---3	55	44	51	40	48	37
40KMC024---3	49	38	45	34	42	31
40KMC03036---3	58	47	55	44	50	39
40KMQ01824---3	49	38	45	34	42	31
40KMQ03036---3	58	47	55	44	50	39

NOTES: Tested in accordance with ARI Standard 270---95 and ARI 350 (no listed in ARI).

WIRING

The indoor and outdoor units have their own power supply (single point connection on units with electric heat). Low voltage wires run between the indoor and outdoor units. Two wires are required for cooling only systems and seven wires are required for heat pumps.

ELECTRICAL DATA

38HDF/38QRF ELECTRICAL DATA

38HDF/38QRF UNIT SIZE	V-PH-Hz	VOLTAGE RANGE*		COMPRESSOR		OUTDOOR FAN MOTOR			MIN CKT AMPS	FUSE/ CKT BKR AMPS
		Min	Max	RLA	LRA	FLA	NEC Hp	kW Out		
018	208/230-1-60	187	253	9.0	48.0	0.80	0.125	0.09	12.1	20
024	208/230-1-60	187	253	12.8	58.3	0.80	0.125	0.09	16.8	25
38QRF030	208/230-1-60	187	253	14.1	73.0	1.50	0.25	0.19	18.4	30
38HDF030	208/230-1-60	187	253	14.1	73.0	0.80	0.125	0.09	18.4	30
035	208/230-1-60	187	253	16.7	79.0	1.50	0.25	0.19	22.3	35
	208/230-3-60	187	253	10.4	73.0	1.50	0.25	0.19	14.5	20
	460-3-60	414	506	5.8	38.0	0.80	0.25	0.19	8.7	15
036	208/230-1-60	187	253	17.9	112.0	1.45	0.25	0.19	23.8	40
	208/230-3-60	187	253	13.2	88.0	1.45	0.25	0.19	18.0	30
	460-3-60	414	506	6.0	44.0	0.80	0.25	0.19	8.3	15

40KMC FAN COIL ELECTRICAL DATA

40KMC Unit Size	V-PH-Hz	Voltage Range		FAN		Condensate Pump FLA	Louver Motor FLA	Power	
		Min.	Max	FLA	Watts			MIN CKT AMPS	FUSE/ CKT BKR AMPS
018	208/230-1-60	187	253	0.55	120	0.06	0.01	0.8	15
024	208/230-1-60	187	253	0.50	110	0.06	0.01	0.7	15
030	208/230-1-60	187	253	0.95	210	0.06	0.01	1.3	15
036	208/230-1-60	187	253	0.95	210	0.06	0.01	1.3	15

40KMQ FAN COIL ELECTRICAL DATA

40KMQ Unit Size	V-PH-Hz	Voltage Range		FAN		Condensate Pump FLA	Louver Motor FLA	Electric Heaters		Power	
		Min.	Max	FLA	Motor Power (Watts)			kW	FLA	MIN CKT AMPS	FUSE/ CKT BKR AMPS
018	208/230-1-60	187	253	0.50	110	0.06	0.01	3	12.5	16.3	20
024	208/230-1-60	187	253	0.50	110	0.06	0.01	3	12.5	16.3	20
030	208/230-1-60	187	253	0.95	210	0.06	0.01	3	12.5	16.9	20
036	208/230-1-60	187	253	0.95	210	0.06	0.01	3	12.5	16.9	20

*Permissible limits of the voltage range at which unit will operate satisfactorily.

LEGEND

- FLA - Full Load Amps
- MCA - Minimum Circuit Amps per NEC Section 430-24
- NEC - National Electrical Code
- RLA - Rated Load Amps (Compressor)

NOTES:

1. In compliance with NEC requirements for multi-motor and combination load equipment (refer to NEC Articles 430 and 440), the over-current protective device for the unit shall be fuse or equipped with a breaker.
2. Motor RLA values are established in accordance with UL (Underwriters Laboratories) Standard 465.



40KMC, KMQ / 38HDF, QRF

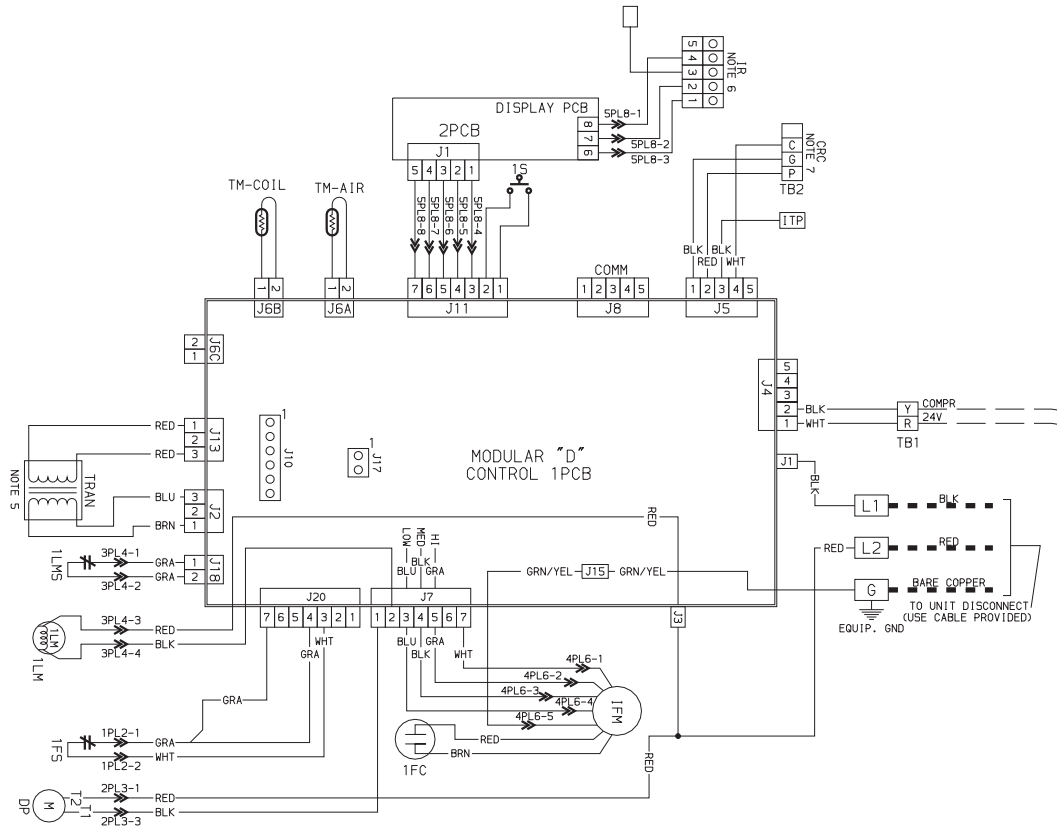

40KMC GLOBAL CASSETTE
38HDF OUTDOOR CONDENSER

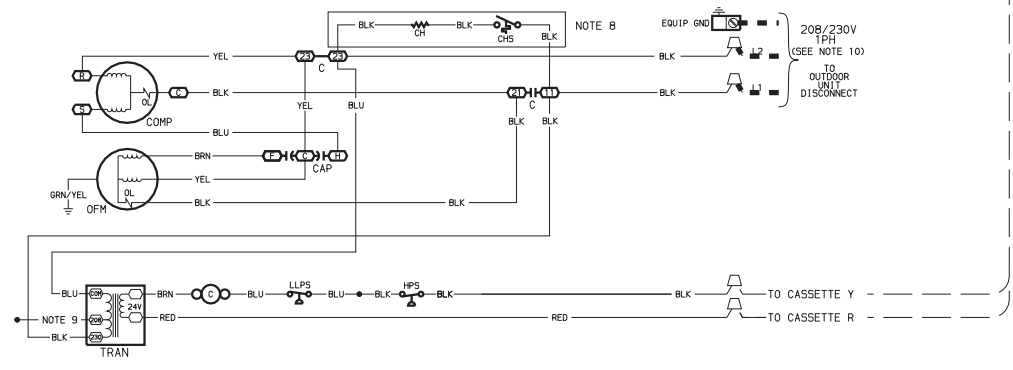

LEGEND

- C CONTACTOR
- CAP CAPACITOR
- CH CRANKCASE HEATER
- COMP COMPRESSOR
- CHS CRANKCASE HEATER SWITCH
- DFB DEFROST THERMOSTAT
- DP DRAIN PUMP
- E-HTR ELECTRIC HEATER
- FE FAN CAPACITOR
- EQUIP.(GND.) EQUIPMENT GROUND
- FS FLOAT SWITCH
- GND GROUND
- HPS HIGH PRESSURE SWITCH
- IFM INDOOR FAN MOTOR
- ITP INDOOR TEST POINT
- LH LOUVER MOTOR
- LLPS LIQUID LOW PRESSURE SWITCH
- LMS LOUVER MICRO SWITCH
- LS LIMIT SWITCH
- OAS OUTDOOR AIR SENSOR
- OPH OUTDOOR FAN MOTOR
- QFR OUTDOOR FAN RELAY
- OL OVERLOAD
- 1PCB MAIN CONTROL PRINTED CIRCUIT BOARD
- 2PCB DISPLAY BOARD
- 3PCB PRINTED CIRCUIT BOARD FOR ELECTRIC HEAT
- RVS REVERSING VALVE SOLENOID
- S SAFETY THERMOSTAT
- ST TERMINAL BLOCK
- TM THERMISTOR
- TRAN TRANSFORMER
- TERMINAL (MARKED)
- TERMINAL (UNMARKED)
- SPLICE
- TERMINAL BLOCK
- FACTORY WIRING
- - - FIELD CONTROL WIRING
- FIELD POWER WIRING
- ACCESSORY OR OPTIONAL WIRING
- ➔ PLUG CONNECTOR

NOTES

1. IF ANY OF THE ORIGINAL WIRE FURNISHED MUST BE REPLACED, IT MUST BE REPLACED WITH TYPE 80°C WIRE OR ITS EQUIVALENT.
2. WIRE IN ACCORDANCE WITH NATIONAL ELECTRICAL CODE (N.E.C.) AND LOCAL CODES.
3. Compressor and fan motors are protected by internal thermal overloads.
4. COMPRESSOR AND FAN MOTORS ARE PROTECTED BY INTERNAL THERMAL OVERLOADS.
5. INDOOR UNIT TRANSFORMER HAS INTERNAL 2A THERMAL FUSE ON THE PRIMARY SIDE.
6. INFARED (I.R.) CONNECTION TO BE INSERTED ON "J5" (REPLACE THE ACTUAL FACTORY INSTALLED "CR" CONNECTOR FOR I.R. OPTION).
7. TERMINAL STRIP FOR CARRIER ROOM CONTROLLER (CRC) CONNECTION.
8. COMPRESSOR CRANKCASE HEATER INSTALLED ON 38QRF03S, AND 38QRF03O.
9. OUTDOOR UNIT TRANSFORMER IS FACTORY WIRED FOR 230V. FOR 208V MOVE THE BLACK WIRE TO THE 208V TAP.
10. USE MINIMUM 60°C WIRE FOR THE FIELD POWER WIRING.

THERMISTOR EQUIVALENCES		
TEMPERATURE		RESISTANCE
°F	°C	Ω
95	35	6,500
72	22	11,400
32	0	32,500
ALL THERMISTORS ARE IDENTICAL		

Fig. 10 – 40KMC / 38HDF Cooling Only System Wiring Diagram

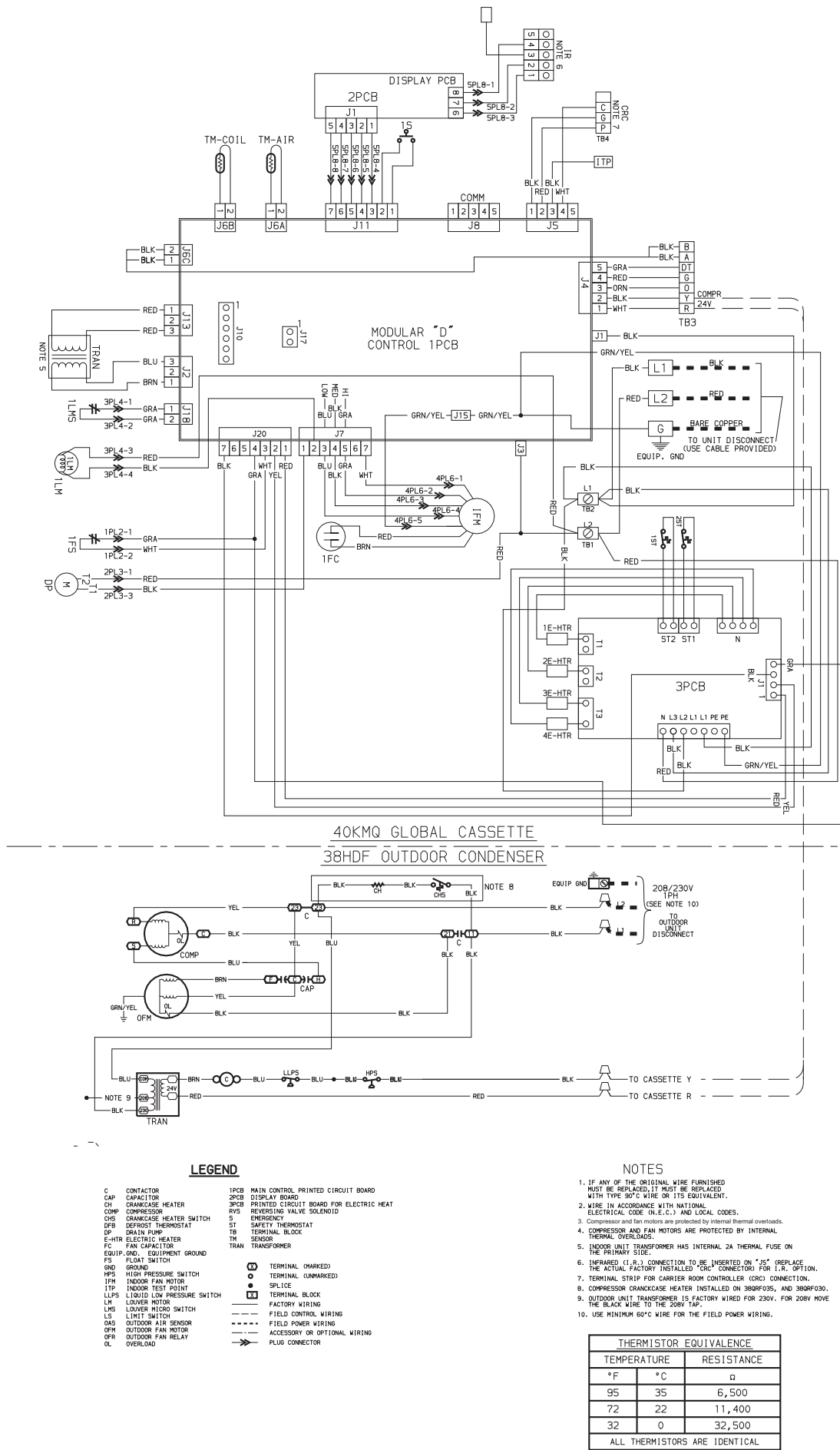

Fig. 11 – 40KMQ / 38HDF Heat/Cool System Wiring Diagram with Electric Heaters

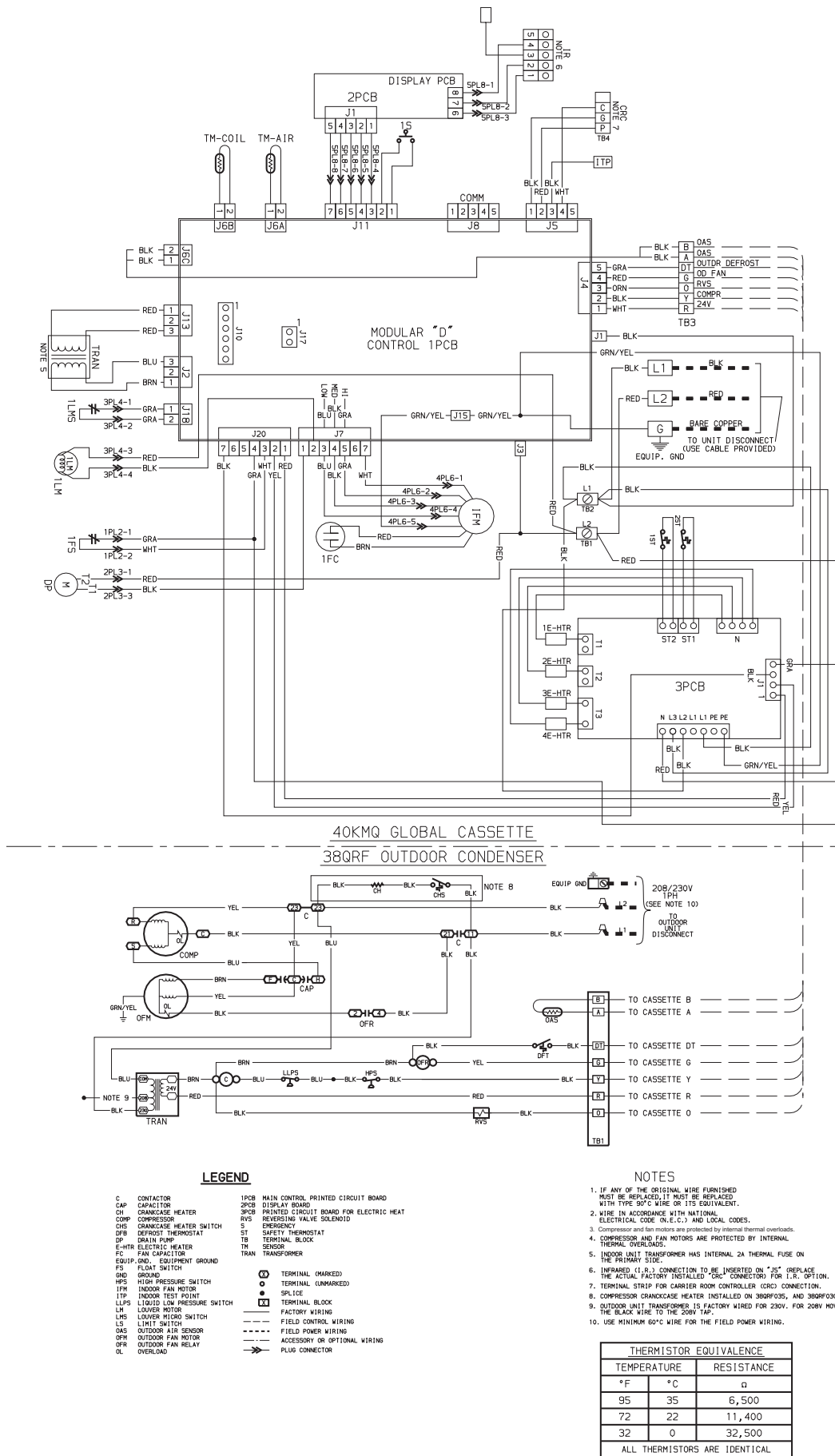

Fig. 12 – 40KMQ / 38QRF Heat Pump System Wiring Diagram with Electric Heaters

GUIDE SPECIFICATIONS

IN-CEILING CASSETTE DUCT-FREE UNITS

Carrier Model Number: 40KMC/40KMQ
Size Range: 1-1/2 to 3 Ton Nominal Cooling Capacity
1-1/2 to 3 Ton Nominal Heating Capacity

PART 1 - GENERAL

1.01 System Description

Indoor, in-ceiling mounted, direct-expansion fan coils are matched with cooling only or heat pump outdoor unit .

1.02 Agency Listings

Unit shall be rated per ARI Standards 210/240 and listed in the ARI directory as a matched system. Units shall be certified by UL and CSA.

1.03 Delivery, Storage, And Handling

Units shall be stored and handled per unit manufacturer's recommendations.

1.04 Warranty

1-year parts limited warranty.

PART 2 - PRODUCTS

2.01 Equipment

A. General:

Indoor, direct-expansion, low profile (12 in./ 304.8 mm) in-ceiling fan coil. Unit shall be complete with cooling/heating (heat pump systems only) coil, fan, fan motor, piping connectors, condensate pump, and hanging brackets.

B. Unit Cabinet:

Cabinet shall be constructed of zinc-coated steel. Fully insulated discharge and inlet grilles shall be attractively styled, high-impact polystyrene.

Grille shall have hinges and can be opened to obtain access to the cleanable filters, indoor fan motor and control box. Adjacent room cooling as well as fresh air intake shall be provided by simple knock-outs in a cabinet side panel.

C. Fans:

1. Fan shall be centrifugal direct-drive blower type with air intake in the center of the unit and discharge at the perimeter. Automatic, motor-driven vertical air sweep shall be provided standard. Automatic motor-driven louvers shall be provided standard and shall be adjustable for 2, 3 or 4-way discharge.
2. Air sweep operation shall be user selectable.

D. Coil:

Coil shall be copper tube with aluminum fins and galvanized steel tube sheets. Fins shall be bonded to the tubes by mechanical expansion and specially coated for enhanced wet-ability. A drip pan under the coil shall have a factory installed condensate pump and drain connection for hose attachment to remove condensate.

E. Motors:

Motors shall be open drip-proof, permanently lubricated ball bearing with inherent overload protection. Fan motors shall be 3-speed.

F. Controls:

Controls shall consist of a microprocessor-based control system which shall control space temperature, determine optimum fan speed, and run self diagnostics. the temperature control range shall be from 62°F to 84°F (16.67°C to 28.89°C).

User interface with the unit shall be accomplished through an accessory wireless remote control (can be configured for °F or °C), or an accessory wired controller or an accessory Zone Manager.

User interface with unit shall be accomplished through either a wireless remote control or a wired control or zone manager.

The unit shall have the following functions as a minimum:

1. An automatic restart after power failure at the same operating conditions as at failure.
2. A timer function to provide a minimum 24-hour timer cycle for system Auto Start/Stop.
3. Temperature-sensing controls shall sense return air temperature.
4. Indoor coil freeze protection.
5. Automatic air sweep control to provide on or off activation of air sweep louvers.
6. Dehumidification mode shall provide increased latent removal capability by modulating system operation and set point temperature.
7. Fan-only operation to provide room air circulation when no cooling is required.
8. Diagnostics shall provide continuous checks of unit operation and warn of possible malfunctions. Error messages shall be displayed at the unit.
9. Fan speed control shall be user-selectable: high, medium, low, or microprocessor controlled automatic operation during all operating modes.
10. Automatic heating-to-cooling changeover in heat pump mode. Control shall include deadband to prevent rapid mode cycling between heating and cooling.
11. Indoor coil high temperature protection shall be provided to detect excessive indoor discharge temperature when unit is in heat pump mode.
12. Cold blow prevention on heat pump units.
13. Automatic compensation for air stratification on heat pump units.

G. Filters:

Unit shall have filter track with factory-supplied cleanable filters.

H. Electric Heat

40KMQ units shall have 3kw electric heaters factory installed to supplement the heating capacity by heat pump when required

I. Electrical Requirements:

Indoor units shall be 208/230-1-60 and require their own power supply. Units with electric heat shall be single power supply. Only control wiring shall run between the indoor and outdoor units.

J. Operating Characteristics:

The 40KMC/KMQ, when matched with the appropriate outdoor section, shall have a minimum listed SEER (seasonal energy efficiency ratio) of 13 at ARI conditions, and a minimum HSPF of 7.7.

K. Special Features (Accessories):

1. User Interface can be accomplished with:
 - Wireless controller
 - Wired control shall be capable of controlling one unit or up to six units daisy-chained together.
 - Zone controller

The zone control can provide the capability of connecting up to 32 units into one or up to 8 independent zones. Each zone can be programmed for 7 days with each day having up to 4 periods.

2. Power ventilation kit shall be available to allow up to 20% outside air to be provided.

GUIDE SPECIFICATIONS

HORIZ. DISCHARGE OUTDOOR UNITS

Carrier Model Number: 38HDF/38QRF

Size Range: 1-1/2 to 3 Ton Nominal Cooling Capacity /1-1/2 to 3 Ton Nominal Heating Capacity

PART 1 - GENERAL

1.01 System Description

- A. Outdoor air-cooled split system compressor sections suitable for on-the-ground, rooftop, wall hung or balcony mounting. Units shall consist of a scroll compressor, an air-cooled coil, propeller-type blow-through outdoor fan, reversing valve (HP), accumulator, Accurator metering device(s), and control box. Units shall discharge air horizontally as shown on the contract drawings. Units shall function as the outdoor component of an air-to-air cooling only, or heat pump system.
- B. Units shall be used in a refrigeration circuit matched to duct-free cooling only or heat pump fan coil units.

1.02 Agency Listings

- A. Unit construction shall comply with ANSI/ASHRAE 15, latest revision, and with the NEC.
- B. Units shall be evaluated in accordance with UL standard 1995.
- C. Units shall be listed in the CEC directory.
- D. Unit cabinet shall be capable of withstanding 500-hour salt spray test per Federal Test Standard No. 141 (method 6061).
- E. Air-cooled condenser coils shall be leak tested at 573 psig.

1.03 Delivery, Storage, And Handling

Units shall be shipped in one piece and shall be stored and handled per unit manufacturer's recommendations.

1.04 Warranty

1-year parts, 5-year compressor limited warranty.

PART 2 - PRODUCTS

2.01 Equipment

A. General:

Factory assembled, single piece, air-cooled outdoor unit. Contained within the unit enclosure shall be all factory wiring, piping, controls, and the compressor.

B. Unit Cabinet:

- 1. Unit cabinet shall be constructed of galvanized steel, bonderized and coated with a baked-enamel finish on inside and outside.
- 2. Unit access panels shall be removable with minimal screws and shall provide full access to the compressor, fan, and control components.
- 3. Outdoor compartment shall be isolated and have an acoustic lining to assure quiet operation.
- 4. Compressor compartment shall be isolated to allow performing diagnostics while the system is running.

C. Fans:

- 1. Outdoor fans shall be direct-drive propeller type, and shall discharge air horizontally. Fans shall blow air through the outdoor coil.
- 2. Outdoor fan motors shall be totally-enclosed, single phase motors with class B insulation and permanently-lubricated bearings. Motor shall be protected by internal thermal overload protection.
- 3. Shaft shall have inherent corrosion resistance.
- 4. Fan blades shall be metallic and shall be statically and dynamically balanced.
- 5. Outdoor fan openings shall be equipped with PVC coated metal protective grille over fan.

D. Compressor:

- 1. Compressor shall be fully hermetic scroll type.
- 2. Compressor shall be equipped with oil system, operating oil charge, and motor. Internal overloads shall protect the compressor from over-temperature and over-current.
- 3. Motor shall be NEMA rated class F, suitable for operation in a refrigerant atmosphere.
- 4. Compressor assembly shall be installed on rubber vibration isolators.
- 5. Compressors shall be available in single-phase (sizes 018-036) and three-phase (sizes 035 and 036).

E. Outdoor Coil:

Coil shall be constructed of aluminum fins mechanically bonded to seamless copper tubes, which are cleaned, dehydrated, and sealed.

F. Refrigeration Components:

Refrigerant circuit components shall include brass external liquid line service valve with service gage port connections, suction line service valve with service gage connection port, service gage port connections on compressor suction and discharge lines with Schrader type fittings with brass caps, accumulator, reversing valve.

G. Controls and Safeties:

Operating controls and safeties shall be factory selected, assembled, and tested. The minimum control functions shall include the following:

- 1. Controls:
 - a. A time delay control sequence is provided standard through the fan coil board.
 - b. Automatic outdoor-fan motor protection.
- 2. Safeties:
 - a. Diagnostics provided by matched indoor unit.
 - b. Compressor motor current and temperature overload protection.
 - c. Outdoor fan failure protection (High Pressure Switch).
 - d. Low pressure protection.
 - e. Fusible plug to vent refrigerant safely in case of a fire.

H. Electrical Requirements:

- 1. All sizes shall operate on single-phase, 60 Hz power at 208/230V or on three-phase, 60 Hz power at either 208/230 or 460 (for size 035 and 036 units).
- 2. Unit control voltage to the indoor fan coil shall be 24 volts AC.
- 3. All power and control wiring must be installed per NEC and all local electrical codes.

I. Refrigerant Line Lengths:

- 1. The unit shall be capable of 200 ft (61 m) maximum piping, a maximum lift (fan coil above) of 65 ft (19.8 m) and a maximum drop (fan coil below) of 200 ft (61 m). Accessories will be required to achieve these lengths.

J. Special Features (Field Installed):

- 1. Low-Ambient Kit: Control shall regulate fan-motor cycles in response to saturated condensing temperature of the unit. The control shall be capable of maintaining a condensing temperature of 100°F ± 10°F (37.78°C ± 5.5°C) with outdoor temperatures to -20°F (-28.9°C). Installation of kit shall not require changing the outdoor fan motor.
- 2. Crankcase Heater
- 3. Wind baffle
- 4. Stacking Kit
- 5. Wall Mounting Kit

