

40MVC / 38MVC  
40MVQ / 38MVQ  
High-Wall Duct Free Split System  
Sizes 009 to 024



Turn to the Experts.™

## Product Data



Worry-FREE. Hassle-FREE. Duct-FREE.™



The ideal compliment to your ducted system when it is impractical or prohibitively expensive to use ductwork.

### INDUSTRY LEADING FEATURES / BENEFITS

#### AN INEXPENSIVE AND CREATIVE SOLUTION TO DESIGN PROBLEMS.

The 38/40MVC(Q) series duct-free split systems are a matched combination of an outdoor condensing unit and an indoor fan coil unit connected only by refrigerant tubing and wires.

The fan coil is mounted on the wall, near the ceiling. This selection of fan coils permits inexpensive and creative solutions to design problems such as:

- Add-ons to current space (an office or family room addition)
- Special space requirements
- When changes in the load cannot be handled by the existing system.
- When adding air conditioning to spaces that are heated by hydronic or electric heat and have no ductwork.
- Historical renovations or any application where preserving the look of the original structure is essential.

These compact indoor fan coil units take up very little space in the room and do not obstruct windows. The fan coils are attractively styled to blend with most room decors. Advanced system components incorporate innovative technology to provide reliable cooling performance at low sound levels.

## LOW SOUND LEVELS

When noise is a concern, the duct-free split systems are the answer. The indoor units are whisper quiet. There are no compressors indoors, either in the conditioned space or directly over it, and there is none of the noise usually generated by air being forced through ductwork.

When sound ordinances and proximity to neighbors demand quiet operation, the 38MVC,MVQ unit is the right choice: The advanced, horizontal airflow design distributes air more evenly over the coil.

## SECURE OPERATION

If security is an issue, outdoor and indoor units are connected only by refrigerant piping and wiring to prevent intruders from crawling through ductwork. In addition, since 38MVC,MVQ units can be installed close to an outside wall, coils are protected from vandals and severe weather.

## FAST INSTALLATION

This compact duct-free split system is simple to install. A mounting bracket is standard with the indoor units and only wire and piping need to be run between indoor and outdoor units. These units are fast and easy to install ensuring minimal disruption to customers in the home or workplace. This makes the 38/40MVC,MVQ duct-free split systems the equipment of choice, especially in retrofit situations.

## SIMPLE SERVICING AND MAINTENANCE

Removing the top panel on outdoor units provides immediate access to the control compartment, providing a service technician access to check unit operation. In addition, the draw-thru design of the outdoor section means that dirt accumulates on the outside surface of the coil. Coils can be cleaned quickly from the inside using a pressure hose and detergent.

On all indoor units, service and maintenance expense is reduced due to easy-to-use cleanable filters. In addition, these high wall systems have extensive self-diagnostics to assist in troubleshooting.

## BUILT-IN RELIABILITY

Duct-free split system indoor and outdoor units are designed to provide years of trouble-free operation.

The high wall indoor units include protection against freeze-up and high evaporator temperatures on heat pumps.

The condensing units and heat pumps are also protected. There is a three minute time delay before the compressor will start. The compressor is also protected by the over-current protection. On size 18k and 24k heat pumps, there is high temperature protection.

## INDIVIDUAL ROOM COMFORT

Maximum comfort is provided because each space can be controlled individually based on usage pattern. The air sweep feature provided permits optimal room air mixing to eliminate hot and cold spots for occupant comfort. In addition, year-round comfort can be provided with heat pumps.

## ECONOMICAL OPERATION

The duct-free split system design allows individual room heating or cooling when required. There is no need to run large supply-air fans or chilled water pumps to handle a few spaces with unique load patterns. In addition, because air is moved only in the space required, no energy is wasted moving air through ducts.

## EASY-TO-USE CONTROLS

The high-wall units have microprocessor-based controls to provided the ultimate in comfort and efficiency. The user friendly wireless remote control provides the interface between user and the unit.

## ACCESSORIES

Customizing these duct-free split systems to your application is easily accomplished. Low-ambient temperature capability (permitting cooling operation down to -20°F (-28.89°C)outdoor ambient) is easily added on all units.

Adding a condensate pump accessory to the high wall fan coil provides installation flexibility.

## AGENCY LISTINGS

All systems are listed with ARI (Air Conditioning & Refrigeration Institute), and ETL.

# MODEL NUMBER NOMENCLATURE

## INDOOR UNIT

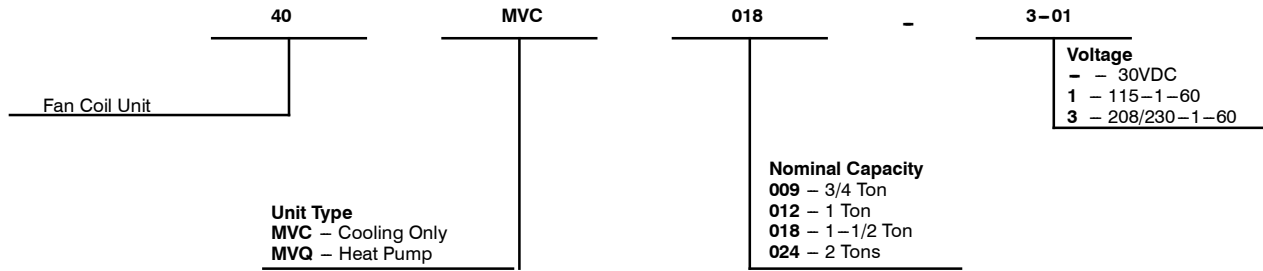

## OUTDOOR UNIT

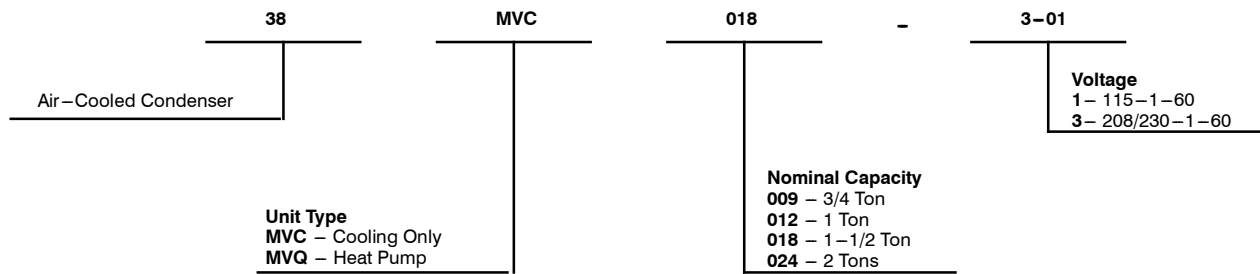

38/40MVC, MVQ

# STANDARD FEATURES AND ACCESSORIES

|  |   |
|--|---|
| <b>Ease Of Installation</b>                                    |   |
| Mounting Brackets  | S |
| Low Voltage Controls   | S |
| <b>Comfort Features</b>  |   |
| Microprocessor Controls  | S |
| Wireless Remote Control  | S |
| Automatic Air Sweep  | S |
| Air Direction Control  | S |
| Auto Restart Function  | S |
| Cold Blow Protection On Heat Pumps                             | S |
| Turbo Mode On Sizes 9K and 12 K                                | S |
| Auto Changeover On Heat Pumps                                  | S |
| <b>Energy Saving Features</b>                                  |   |
| Sleep Mode   | S |
| Stop/Start Timer   | S |
| <b>Safety And Reliability</b>                                  |   |
| 3 Minute Time Delay For Compressor                             | S |
| Over Current Protection For Compressor                         | S |
| Indoor Coil Freeze Protection                                  | S |
| Indoor Coil High Temperature Protection On Heat Pumps          | S |
| Condenser High Temperature Protection On heat Pumps†           | S |
| Accumulator On Heat Pumps                                      | S |
| <b>Ease Of Service And Maintenance</b>                         |   |
| Cleanable Filters  | S |
| Diagnostics  | S |
| Liquid Line Pressure Taps                                      | S |
| Suction And Discharge Pressure Taps (Sizes 18 and 24K)         | S |
| <b>Application Flexibility</b>                                 |   |
| Low Ambient Controls (-20° F)                                  | A |
| Condensate Pumps   | A |
| Crankcase Heater   | A |
| Wind Baffles   | F |
| <b>Warranty</b>  |   |
| 5 - Year Compressor Warranty                                   | S |
| 1 - Parts Warranty   | S |
| Compressor Extended Warranty Years 6 Thru 10                   | O |
| All Parts And Labor Years 2 Thru 5                             | O |
| All Parts And Labor Years 2 Thru 5, Compressor Years 6 Thru 10 | O |

† Sizes 18k & 24k

**Legend**

- S Standard
- A Accessory
- O Optional
- F Field Fabricated

38/40MVC, MVQ

## INDOOR UNITS

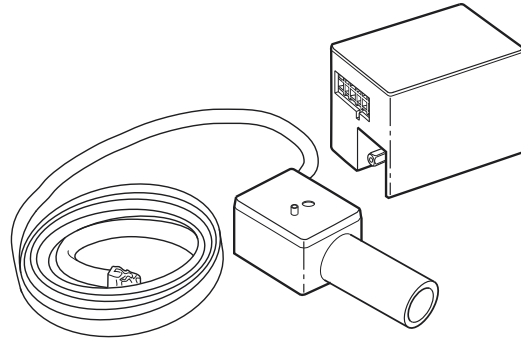

A07892

**Fig. 1 – Condensate Pump Accessory**

On high wall fan coils, the condensate pump has a lift capability of 12 ft (3.6 m) on the discharge side with the pump mounted in the fan coil or 6 ft (1.8 m) on the suction side if the pump is remote mounted. The pump is recommended when adequate drain line pitch cannot be provided, or when the condensate must move up to exit.

**NOTE:** An external 115v power source will be required to run the pump on unit sizes 9k and 12k.

## OUTDOOR UNITS

### LOW AMBIENT KIT

The kit controls condenser fan cycling using a pressure switch. It is specifically designed to control fan-motor cycles in response to saturated condensing pressure. This device maintains a constant saturated condensing temperature of 100 °F ± 10 °F (37.78°C ± -12.22 °C) at outdoor-air temperatures between 55 °F and -20 °F (12.78°C ± -12.22°C), and can be used on all outdoor units without changing the outdoor fan motor.

### CRANKCASE HEATER

Available for units with rotary compressors. Heater clamps around compressor oil sump. Recommended for low-ambient applications on sizes 9, 12, 18, 24 and long line applications.

## AHRI\* CAPACITY RATINGS

| OUTDOOR SECTION | INDOOR SECTION | STANDARD CFM |        | COOLING BTUH | SEER | HIGH HEAT |      |
|-----------------|----------------|--------------|--------|--------------|------|-----------|------|
|                 |                | Outdoor      | Indoor |              |      | BTUH      | HSPF |
| 38MVC009---1    | 40MVC009---1   | 1000         | 325    | 9,200        | 13   | N/A       | N/A  |
| 38MVC012---1    | 40MVC012---1   | 1000         | 425    | 11,400       | 13   | N/A       | N/A  |
| 38MVC012---3    | 40MVC012---3   | 1000         | 425    | 11,800       | 13   | N/A       | N/A  |
| 38MVC018---3    | 40MVC018---3   | 1600         | 630    | 17,500       | 13   | N/A       | N/A  |
| 38MVC024---3    | 40MVC024---3   | 1600         | 750    | 22,000       | 13   | N/A       | N/A  |
| 38MVQ009---1    | 40MVQ009---1   | 1000         | 325    | 9,600        | 13   | 9,400     | 7.7  |
| 38MVQ012---1    | 40MVQ012---1   | 1000         | 425    | 11,500       | 13   | 11,500    | 7.7  |
| 38MVQ012---3    | 40MVQ012---3   | 1000         | 425    | 12,000       | 13   | 11,500    | 7.7  |
| 38MVQ018---3    | 40MVQ018---3   | 1600         | 560    | 17,500       | 13   | 17,000    | 7.7  |
| 38MVQ024---3    | 40MVQ024---3   | 1600         | 750    | 22,500       | 13   | 21,500    | 7.7  |

\*Air Conditioning, Heating & Refrigeration Institute

**Legend**

**HSPF** – Heating Seasonal Performance Factor

**SEER** – Seasonal Energy Efficiency Ratio

**NOTES:**

- Ratings are net values reflecting the effects of circulating fan heat. Ratings are based on: Cooling Standard: 80°F (26.67°C) db, 67°F (19.44°C) wb air entering indoor unit and 95°F (35°C) db air entering outdoor unit. High Temperature Heating Standard: 70°F (21.11°C) db air entering indoor unit and 47°F (8.33°C) db, 43°F (6.11°C) wb air entering outdoor unit.
- Ratings are based on 25 ft. (7.62 m) of interconnecting refrigerant lines.
- All system ratings are based on fan coil units operating at high fan speed. Consult Physical Data tables for airflows at all available fan speeds.

## DIMENSIONS - INDOOR

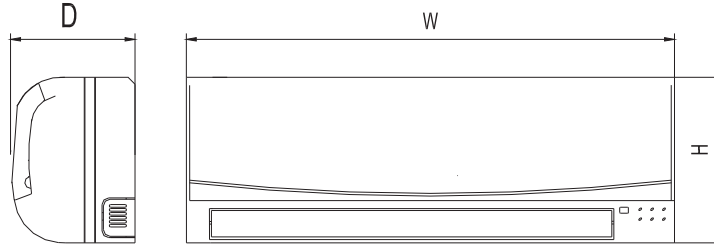

A07336

| Model Size | W<br>in. (mm) | H<br>in. (mm) | D<br>in. (mm) | Operating Weight lb (kg) |
|------------|---------------|---------------|---------------|--------------------------|
| 9K         | 32.09 (815)   | 11.02 (280)   | 7.68 (195)    | 17.6 (8)                 |
| 12K        | 35.67 (906)   | 11.26 (286)   | 9.25 (235)    | 25.3 (11.5)              |
| 18K        | 49.21 (1250)  | 12.80 (325)   | 9.06 (230)    | 39.6 (18)                |
| 24K        | 49.21 (1250)  | 12.80 (325)   | 9.06 (230)    | 39.6 (18)                |

## DIMENSIONS - OUTDOOR

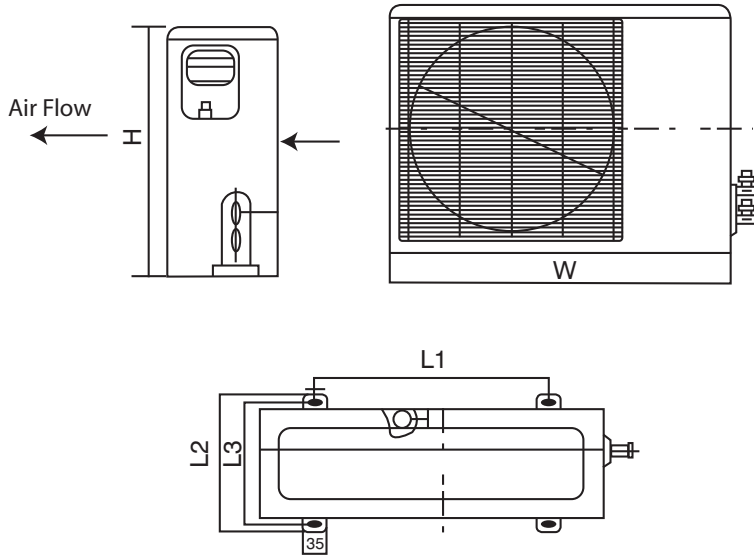

A07337

| Model Size | W<br>in. (mm) | H<br>in. (mm) | L1<br>in. (mm) | L2<br>in. (mm) | L3<br>in. (mm) | Operating Weight<br>lb (kg)<br>Cooling Only | Operating Weight<br>lb (kg)<br>Heat Pumps |
|------------|---------------|---------------|----------------|----------------|----------------|---|---|
| 9K         | 30.71 (780)   | 21.26 (540)   | 21.61 (549)    | 11.81 (300)    | 10.87 (276)    | 70.4 (32)                                   | 72.6 (33)                                 |
| 12K        | 29.92 (760)   | 23.23 (590)   | 20.87 (530)    | 12.40 (315)    | 11.42 (290)    | 79.2 (36)                                   | 83.6 (38)                                 |
| 18K        | 33.07 (840)   | 27.36 (695)   | 22.05 (560)    | 14.17 (360)    | 13.19 (335)    | 116.6 (53)                                  | 117.7 (53.5)                              |
| 24K        | 35.00 (889)   | 33.50 (851)   | 23.11 (588)    | 13.98 (355)    | 13.11 (333)    | 149.6 (68)                                  | 151 (68.5)                                |

## SERVICE VALVE LOCATIONS

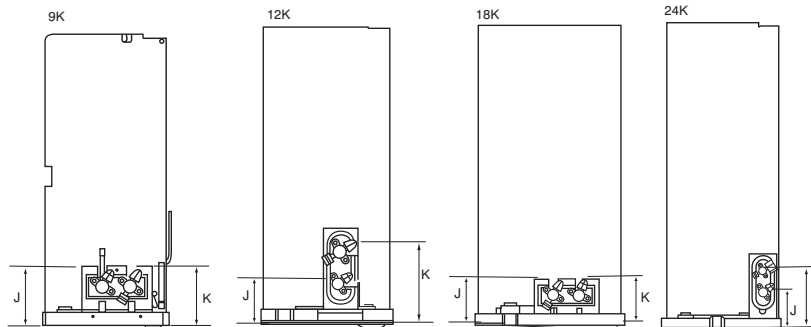

A07376a

| Service Valve Locations | 9K<br>in. (mm) | 12K<br>in. (mm) | 18K<br>in. (mm) | 24K<br>in. (mm) |
|-------------------------|----------------|-----------------|-----------------|-----------------|
| J                       | 3.46 (88)      | 3.19 (81)       | 3.46 (88)       | 4.02 (102)      |
| K                       | 3.46 (88)      | 5.63 (143)      | 3.62 (92)       | 6.57 (167)      |

## CLEARANCES - INDOOR

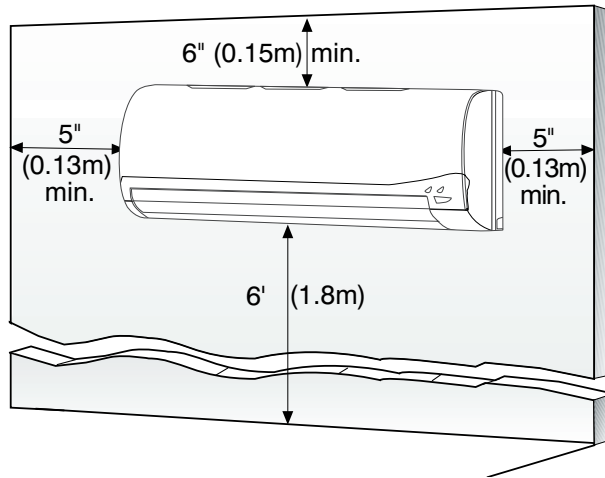

A07891

Fig. 2 – Indoor unit clearance

38/40MVC, MVQ

## CLEARANCES - OUTDOOR

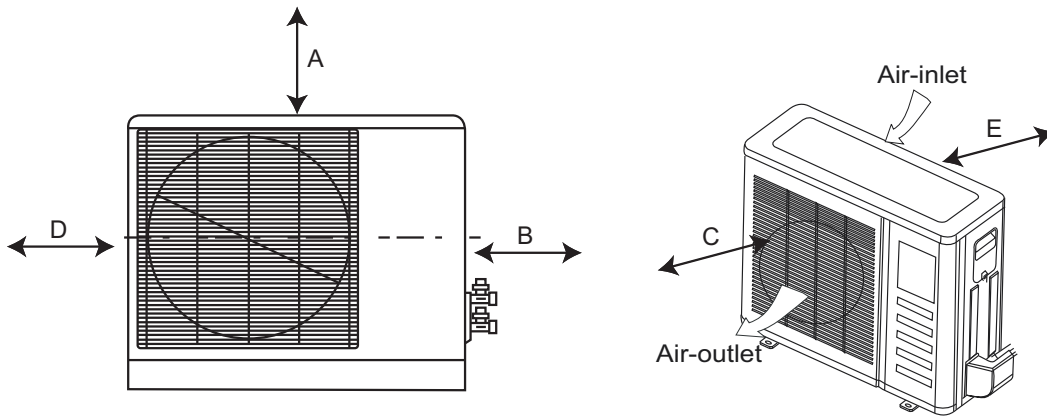

A07894

| UNIT | 9k and 12k in. (mm) | 18k and 24k in. (mm) |
|------|---------------------|----------------------|
| A    | 24 (610)            | 24 (610)             |
| B    | 24 (610)            | 36 (914)             |
| C    | 24 (610)            | 24 (610)             |
| D    | 6 (152)             | 6 (152)              |
| E    | 12 (305)            | 12 (305)             |

Fig. 3 – Outdoor Unit Clearance

# PHYSICAL DATA

| Outdoor Unit 38MVC               | 009                       | 012             | 012            | 018            | 24             |
|----------------------------------|---------------------------|-----------------|----------------|----------------|----------------|
| <b>System Voltage</b>            | 115 V                     | 115 V           | 208/230        | 208/230        | 208/230        |
| <b>Nominal Capacity (Btuh)</b>   | 9000                      | 12000           | 12000          | 18000          | 24000          |
| <b>Operating Weight lb(kg)</b>   | 70.4(32)                  | 79.2(36)        | 79.2(36)       | 116.6(53)      | 149.6(68)      |
| <b>Refrigerant Type</b>          | R-410A                    |                 |                |                |                |
| <b>Metering Device</b>           | Capillary Tube at Outdoor |                 |                |                |                |
| <b>Charge lb (kg)</b>            | 2.3 (1.0)                 | 2.9 (1.3)       | 3.0 (1.4)      | 4.4 (2.0)      | 5.3 (2.4)      |
| <b>Compressor</b>                | Rotary                    |                 |                |                |                |
| Type                             | Rotary                    |                 |                |                |                |
| Model                            | EA82X1C-1FZDU1            | EA108X1C-1FZDU1 | PA108X1C-3FZDU | PA150X2CS-3KUU | PA200X2CS-3MUU |
| Oil Charge (POE -oz)             | 11.8                      | 11.8            | 11.8           | 25.4           | 25.4           |
| <b>Outdoor Fan</b>               |                           |                 |                |                |                |
| Rpm                              | 900                       | 900             | 900            | 840            | 740            |
| Diameter (in) .. No. of Blades   | 15.8 ... 3                | 15.8 ... 3      | 15.8 ... 3     | 18.1 ... 3     | 18.1 ... 3     |
| Motor (watts / hp)               | 23 / 0.102                | 23 / 0.102      | 23 / 0.102     | 53 / 0.224     | 100 / 0.218    |
| <b>Outdoor Coil</b>              |                           |                 |                |                |                |
| Face Area (sq. ft)               | 4.05                      | 3.94            | 3.94           | 5.51           | 6.67           |
| No. Rows                         | 2                         | 2               | 2              | 4              | 3              |
| Fins per inch                    | 17                        | 17              | 17             | 18             | 18             |
| Circuits                         | 4                         | 4               | 4              | 4              | 6              |
| <b>Refrigerant Lines</b>         | Flare                     |                 |                |                |                |
| Connection Type                  | Flare                     |                 |                |                |                |
| Liquid (Mix Phase) (in) OD       | 1/4"                      | 1/4"            | 1/4"           | 1/4"           | 3/8"           |
| Vapor Line (in) OD               | 3/8"                      | 1/2"            | 1/2"           | 1/2"           | 5/8"           |
| Maximum Length* ft (m)           | 65 (20.0)                 | 65 (20.0)       | 65 (20.0)      | 100 (30.4)     | 100 (30.4)     |
| Max Lift (Fan Coil Above) ft (m) | 35 (10.7)                 | 35 (10.7)       | 35 (10.7)      | 50 (12.2)      | 60 (18.3)      |
| Max Drop (Fan Coil Below)ft (m)  | 35 (10.7)                 | 35 (10.7)       | 35 (10.7)      | 50 (12.2)      | 60 (18.3)      |
| <b>Controls</b>                  |                           |                 |                |                |                |
| Control Voltage                  | 13 VDC                    | 13 VDC          | 13 VDC         | Pulse DC       | Pulse DC       |
| <b>External Finish</b>           | White                     | White           | White          | White          | White          |

38/40MVC, MVQ

| Outdoor Unit 38MVQ               | 009                       | 012             | 012            | 018            | 024            |
|----------------------------------|---------------------------|-----------------|----------------|----------------|----------------|
| <b>System Voltage</b>            | 115 V                     | 115 V           | 208/230        | 208/230        | 208/230        |
| <b>Nominal Capacity (Btuh)</b>   | 9000                      | 12000           | 12000          | 18000          | 24000          |
| <b>Operating Weight lb(kg)</b>   | 72.6 (33)                 | 83.6 (38)       | 83.6 (38)      | 117.7 (53.5)   | 151.0 (68.5)   |
| <b>Refrigerant Type</b>          | R-410A                    |                 |                |                |                |
| <b>Metering Device</b>           | Capillary Tube at Outdoor |                 |                |                |                |
| <b>Charge lb (kg)</b>            | 2.4 (1.1)                 | 3.0 (1.4)       | 3.0 (1.4)      | 4.5 (2.0)      | 5.3 (2.4)      |
| <b>Compressor</b>                | Rotary                    |                 |                |                |                |
| Type                             | Rotary                    |                 |                |                |                |
| Model                            | EA82X1C-1FZDU1            | EA108X1C-1FZDU1 | PA108X1C-3FZDU | PA150X2CS-3KUU | PA200X2CS-3MUU |
| Oil Charge (POE -oz)             | 11.8                      | 11.8            | 11.8           | 25.4           | 25.4           |
| <b>Outdoor Fan</b>               |                           |                 |                |                |                |
| Rpm                              | 900                       | 900             | 900            | 840            | 740            |
| Diameter (in) .. No. of Blades   | 15.8 ... 3                | 15.8 ... 3      | 15.8 ... 3     | 18.1 ... 3     | 18.1 ... 3     |
| Motor (watts / hp)               | 23 / 0.102                | 23 / 0.102      | 23 / 0.102     | 53 / 0.224     | 100 / 0.218    |
| <b>Outdoor Coil</b>              |                           |                 |                |                |                |
| Face Area (sq. ft)               | 4.05                      | 3.94            | 3.94           | 5.51           | 6.67           |
| No. Rows                         | 2                         | 2               | 2              | 2              | 3              |
| Fins per inch                    | 17                        | 18              | 18             | 18             | 18             |
| Circuits                         | 4                         | 4               | 4              | 4              | 6              |
| <b>Refrigerant Lines</b>         | Flare                     |                 |                |                |                |
| Connection Type                  | Flare                     |                 |                |                |                |
| Liquid Line (in) OD              | 1/4"                      | 1/4"            | 1/4"           | 1/4"           | 3/8"           |
| Vapor Line (in) OD               | 3/8"                      | 1/2"            | 1/2"           | 1/2"           | 5/8"           |
| Maximum Length* ft (m)           | 65 (20.0)                 | 65 (20.0)       | 65 (20.0)      | 100 (30.4)     | 100 (30.4)     |
| Max Lift (Fan Coil Above) ft (m) | 35 (10.7)                 | 35 (10.7)       | 35 (10.7)      | 50 (12.2)      | 60 (18.3)      |
| Max Drop (Fan Coil Below)ft (m)  | 35 (10.7)                 | 35 (10.7)       | 35 (10.7)      | 50 (12.2)      | 60 (18.3)      |
| <b>Controls</b>                  |                           |                 |                |                |                |
| Control Voltage                  | 13 VDC                    | 13 VDC          | 13 VDC         | Pulse DC       | Pulse DC       |
| <b>Finish</b>                    | White                     | White           | White          | White          | White          |

\* Refer to Long Line Application section on page 21

# PHYSICAL DATA (CONT.)

| Indoor Unit 40MVC               | 009                       | 012               | 018               | 024               |
|---------------------------------|---------------------------|-------------------|-------------------|-------------------|
| <b>System Voltage</b>           | 115                       | 115 or 208/230    | 208/230           | 208/230           |
| <b>Nominal Capacity (Btuh)</b>  | 9000                      | 12000             | 18000             | 24,000            |
| <b>Operating Weight lb(kg)</b>  | 17.6(8)                   | 25.3(11.5)        | 39.6(18)          | 39.6(18)          |
| <b>Refrigerant Type</b>         | R-410A                    |                   |                   |                   |
| <b>Metering Device</b>          | Capillary Tube at Outdoor |                   |                   |                   |
| <b>Charge (lb)</b>              | 2.3(1.0)                  | 2.9(1.3)          | 4.4(2.0)          | 5.3(2.4)          |
| <b>Indoor Fan</b>               |                           |                   |                   |                   |
| Rpm/Cfm (High)                  | 1250/325                  | 1270/425          | 1070/630          | 1070/750          |
| Rpm/Cfm (Medium)                | 1000/260                  | 1100/365          | 1000/570          | 1000/660          |
| Rpm/Cfm (Low)                   | 800/190                   | 1000/340          | 960/500           | 960/585           |
| Motor (Watts / hp)              | 20 / .034                 | 25 / .044         | 31 / .075         | 50 / .112         |
| Blower Diameter ... Length (in) | 3.84 ... 25.87            | 4.17 ... 25.2     | 4.21 ... 37.6     | 4.21 ... 37.6     |
| <b>Indoor Coil</b>              |                           |                   |                   |                   |
| Face Area (sq. ft)              | 2.15                      | 2.54              | 4.36              | 4.36              |
| No. Rows                        | 2                         | 2                 | 2                 | 2                 |
| Fins per inch                   | 19.5                      | 19.5              | 19.5              | 19.5              |
| Circuits                        | 2                         | 3                 | 6                 | 6                 |
| <b>Controls</b>                 | Integrated Microprocessor |                   |                   |                   |
| Remote Controller               | Wireless                  |                   |                   |                   |
| <b>Fan Mode</b>                 | High/Medium/Low/Auto      |                   |                   |                   |
| Turbo Mode                      | Yes                       | Yes               | No                | No                |
| Dehumidification Mode           | Yes                       |                   |                   |                   |
| Sleep Mode                      | Yes                       |                   |                   |                   |
| Diagnostics                     | Yes                       |                   |                   |                   |
| Timer Mode                      | Yes                       |                   |                   |                   |
| Freeze Protection               | Yes                       |                   |                   |                   |
| Test Mode                       | Yes                       |                   |                   |                   |
| Auto Restart                    | Yes                       |                   |                   |                   |
| Auto Sweep                      | Yes                       |                   |                   |                   |
| Control Voltage                 | 13 VDC                    | 13 VDC            | Pulse DC          | Pulse DC          |
| <b>Refrigerant Lines</b>        |                           |                   |                   |                   |
| Connection Type                 | Flare                     |                   |                   |                   |
| Liquid Line (in) OD             | 1/4"                      | 1/4"              | 1/4"              | 3/8"              |
| Vapor Line (in) OD              | 3/8"                      | 1/2"              | 1/2"              | 5/8"              |
| Maximum Length ft(m)*           | 65(19.8)                  | 65(19.8)          | 100(30.5)         | 100(30.5)         |
| Max Lift (Fan Coil Above) ft(m) | 35(10.7)                  | 35(10.7)          | 50(15.2)          | 60(18.3)          |
| Max Drop (Fan Coil Below) ft(m) | 35(10.7)                  | 35(10.7)          | 50(15.2)          | 60(18.3)          |
| <b>Condensate Drain</b>         |                           |                   |                   |                   |
| Size (in)                       | .65 (OD) .53 (ID)         | .65 (OD) .53 (ID) | .65 (OD) .53 (ID) | .65 (OD) .53 (ID) |
| <b>External Finish</b>          | White                     | White             | White             | White             |

\* Refer to Long Line Application section on page 21

38/40MVC, MVQ

# PHYSICAL DATA (CONT.)

| Indoor Unit 40MVQ                | 009                       | 012               | 018               | 024               |
|----------------------------------|---------------------------|-------------------|-------------------|-------------------|
| <b>System Voltage</b>            | 115                       | 115 or 208/230    | 208/230           | 208/230           |
| <b>Nominal Capacity (Btuh)</b>   | 9000                      | 12000             | 18000             | 24000             |
| <b>Operating Weight lb (kg)</b>  | 17.6 (8)                  | 25.3 (11.5)       | 39.6 (18)         | 39.6 (18)         |
| <b>Refrigerant Type</b>          | R-410A                    |                   |                   |                   |
| <b>Metering Device</b>           | Capillary Tube at Outdoor |                   |                   |                   |
| <b>Charge lb (kg)</b>            | 2.35 (1.1)                | 3.0 (1.4)         | 4.5 (2.0)         | 5.3 (2.4)         |
| <b>Indoor Fan</b>                |                           |                   |                   |                   |
| Rpm/Cfm (High)                   | 1250/325                  | 1270/425          | 1070/630          | 1070/750          |
| Rpm/Cfm (Medium)                 | 1000/260                  | 1100/365          | 1000/570          | 1000/660          |
| Rpm/Cfm (Low)                    | 800/190                   | 1000/340          | 960/500           | 960/585           |
| Motor (Watts / hp)               | 20 / .034                 | 25 / .044         | 31 / .075         | 50 / .112         |
| Blower Diameter ... Length (in)  | 3.84 ... 25.87            | 4.17 ... 25.2     | 4.21 ... 37.6     | 4.21 ... 37.6     |
| <b>Indoor Coil</b>               |                           |                   |                   |                   |
| Face Area (sq. ft)               | 2.15                      | 2.54              | 4.36              | 4.36              |
| No. Rows                         | 2                         | 2                 | 2                 | 2                 |
| Fins per inch                    | 19.5                      | 19.5              | 19.5              | 19.5              |
| Circuits                         | 2                         | 3                 | 6                 | 6                 |
| <b>Controls</b>                  | Integrated Microprocessor |                   |                   |                   |
| Remote Controller                | Wireless                  |                   |                   |                   |
| Fan Mode                         | High/Medium/Low/Auto      |                   |                   |                   |
| Auto Changeover                  | Yes                       |                   |                   |                   |
| Dehumidification Mode            | Yes                       |                   |                   |                   |
| Demand Defrost                   | Yes                       |                   |                   |                   |
| Sleep Mode                       | Yes                       |                   |                   |                   |
| Diagnostics                      | Yes                       |                   |                   |                   |
| Timer Mode                       | Yes                       |                   |                   |                   |
| Freeze Protection                | Yes                       |                   |                   |                   |
| Test Mode                        | Yes                       |                   |                   |                   |
| Auto Restart                     | Yes                       |                   |                   |                   |
| Auto Sweep                       | Yes                       |                   |                   |                   |
| Control Voltage                  | 13 VDC                    | 13 VDC            | Pulse DC          | Pulse DC          |
| <b>Refrigerant Lines</b>         |                           |                   |                   |                   |
| Connection Type                  | Flare                     |                   |                   |                   |
| Liquid Line (in) OD              | 1/4"                      | 1/4"              | 1/4"              | 3/8"              |
| Vapor Line (in) OD               | 3/8"                      | 1/2"              | 1/2"              | 5/8"              |
| Maximum Length* ft (m)           | 65 (19.8)                 | 65 (19.8)         | 100 (30.5)        | 100 (30.5)        |
| Max Lift (Fan Coil Above) ft (m) | 35 (10.7)                 | 35 (10.7)         | 50 (15.2)         | 60 (18.3)         |
| Max Drop (Fan Coil Below) ft (m) | 35 (10.7)                 | 35 (10.7)         | 50 (15.2)         | 60 (18.3)         |
| <b>Condensate Drain</b>          |                           |                   |                   |                   |
| Size (in)                        | .65 (OD) .53 (ID)         | .65 (OD) .53 (ID) | .65 (OD) .53 (ID) | .65 (OD) .53 (ID) |
| <b>External Finish</b>           | White                     | White             | White             | White             |

\* Refer to Long Line Application section on page 21

38/40MVQ, MVQ

# PERFORMANCE DATA

## COOLING CAPACITIES 38MVC(Q)009-1 / 40MVC(Q)009-1

| Temp °F (°C)<br>Air Entering<br>Condenser<br>(Edb) | Air Entering Evaporator – Cfm/BF      |               |               |               |               |               |               |               |               |               |               |               |       |
|--|---------------------------------------|---------------|---------------|---------------|---------------|---------------|---------------|---------------|---------------|---------------|---------------|---------------|-------|
|  | 190/0.04                              |               |               |               | 259/0.04      |               |               |               | 327/0.05      |               |               |               |       |
|  | Air Entering Evaporator – Ewb °F (°C) |               |               |               |               |               |               |               |               |               |               |               |       |
|  | 57<br>(13.89)                         | 62<br>(16.67) | 67<br>(19.44) | 72<br>(22.22) | 57<br>(13.89) | 62<br>(16.67) | 67<br>(19.44) | 72<br>(22.22) | 57<br>(13.89) | 62<br>(16.67) | 67<br>(19.44) | 72<br>(22.22) |       |
| 55<br>(12.78)                                      | TCG                                   | 7.70          | 8.60          | 9.37          | 10.14         | 9.08          | 9.34          | 10.07         | 10.66         | 9.75          | 9.74          | 10.44         | 10.93 |
|  | SHG                                   | 7.44          | 6.61          | 5.80          | 4.95          | 9.08          | 7.59          | 6.45          | 5.29          | 9.75          | 8.30          | 6.95          | 5.50  |
|  | TC                                    | 7.69          | 8.58          | 9.36          | 10.12         | 9.07          | 9.32          | 10.06         | 10.65         | 9.74          | 9.72          | 10.42         | 10.92 |
|  | kW                                    | 0.48          | 0.48          | 0.48          | 0.47          | 0.48          | 0.48          | 0.47          | 0.47          | 0.48          | 0.48          | 0.47          | 0.47  |
|  | CMP                                   | 0.39          | 0.39          | 0.39          | 0.38          | 0.39          | 0.39          | 0.38          | 0.38          | 0.39          | 0.39          | 0.38          | 0.38  |
|  | LDB                                   | 45.0          | 48.9          | 52.8          | 56.9          | 48.4          | 53.5          | 57.6          | 61.7          | 52.9          | 56.9          | 60.7          | 64.8  |
| 65<br>(18.33)                                      | LWB                                   | 40.9          | 45.6          | 50.8          | 56.2          | 43.3          | 49.2          | 54.5          | 60.2          | 45.4          | 51.6          | 56.9          | 62.6  |
|  | TCG                                   | 7.40          | 8.31          | 9.14          | 9.95          | 8.88          | 9.08          | 9.87          | 10.51         | 9.53          | 9.50          | 10.27         | 10.81 |
|  | SHG                                   | 7.40          | 6.57          | 5.71          | 4.88          | 8.88          | 7.55          | 6.41          | 5.25          | 9.53          | 8.34          | 6.98          | 5.51  |
|  | TC                                    | 7.38          | 8.29          | 9.13          | 9.93          | 8.86          | 9.07          | 9.85          | 10.50         | 9.52          | 9.48          | 10.26         | 10.80 |
|  | kW                                    | 0.54          | 0.55          | 0.55          | 0.54          | 0.55          | 0.55          | 0.54          | 0.54          | 0.55          | 0.55          | 0.54          | 0.54  |
|  | CMP                                   | 0.45          | 0.45          | 0.46          | 0.45          | 0.46          | 0.46          | 0.45          | 0.45          | 0.45          | 0.45          | 0.45          | 0.45  |
| 75<br>(23.89)                                      | LDB                                   | 45.1          | 49.1          | 53.2          | 57.2          | 49.1          | 53.6          | 57.7          | 61.9          | 53.5          | 56.7          | 60.6          | 64.8  |
|  | LWB                                   | 41.6          | 46.2          | 51.2          | 56.5          | 43.6          | 49.6          | 54.8          | 60.3          | 45.7          | 51.9          | 57.1          | 62.7  |
|  | TCG                                   | 7.50          | 7.94          | 8.88          | 9.73          | 8.56          | 8.72          | 9.57          | 10.33         | 9.28          | 9.12          | 10.00         | 10.61 |
|  | SHG                                   | 7.50          | 6.52          | 5.62          | 4.80          | 8.56          | 7.49          | 6.33          | 5.21          | 9.28          | 8.24          | 6.93          | 5.50  |
|  | TC                                    | 7.49          | 7.93          | 8.87          | 9.71          | 8.54          | 8.70          | 9.55          | 10.31         | 9.26          | 9.10          | 9.98          | 10.60 |
|  | kW                                    | 0.61          | 0.61          | 0.62          | 0.62          | 0.62          | 0.62          | 0.62          | 0.62          | 0.62          | 0.62          | 0.62          | 0.62  |
| 85<br>(29.44)                                      | CMP                                   | 0.52          | 0.52          | 0.53          | 0.52          | 0.52          | 0.53          | 0.53          | 0.52          | 0.53          | 0.53          | 0.52          | 0.52  |
|  | LDB                                   | 44.7          | 49.2          | 53.6          | 57.6          | 50.1          | 53.8          | 57.9          | 62.0          | 54.2          | 57.0          | 60.7          | 64.8  |
|  | LWB                                   | 41.4          | 47.0          | 51.7          | 56.9          | 44.1          | 50.1          | 55.2          | 60.6          | 46.0          | 52.3          | 57.4          | 62.8  |
|  | TCG                                   | 7.20          | 7.55          | 8.50          | 9.42          | 8.20          | 8.09          | 9.25          | 10.04         | 8.99          | 8.72          | 9.62          | 10.34 |
|  | SHG                                   | 7.20          | 6.49          | 5.52          | 4.67          | 8.20          | 7.34          | 6.28          | 5.12          | 8.99          | 8.23          | 6.86          | 5.44  |
|  | TC                                    | 7.18          | 7.53          | 8.48          | 9.41          | 8.19          | 8.07          | 9.23          | 10.03         | 8.97          | 8.71          | 9.61          | 10.33 |
| 95<br>(35)   | kW                                    | 0.68          | 0.69          | 0.69          | 0.70          | 0.69          | 0.69          | 0.70          | 0.70          | 0.70          | 0.70          | 0.70          | 0.70  |
|  | CMP                                   | 0.59          | 0.59          | 0.60          | 0.60          | 0.60          | 0.60          | 0.60          | 0.60          | 0.60          | 0.60          | 0.60          | 0.60  |
|  | LDB                                   | 46.0          | 49.3          | 54.0          | 58.2          | 51.3          | 54.3          | 58.1          | 62.3          | 54.9          | 57.0          | 60.9          | 65.0  |
|  | LWB                                   | 42.1          | 47.8          | 52.5          | 57.5          | 44.7          | 51.1          | 55.6          | 60.9          | 46.4          | 52.7          | 57.8          | 63.1  |
|  | TCG                                   | 6.86          | 7.02          | 8.06          | 9.06          | 7.82          | 7.63          | 8.86          | 9.66          | 8.57          | 8.22          | 9.22          | 9.98  |
|  | SHG                                   | 6.86          | 6.37          | 5.42          | 4.53          | 7.82          | 7.28          | 6.20          | 5.00          | 8.57          | 8.22          | 6.83          | 5.35  |
| 105<br>(40.56)                                     | TC                                    | 6.85          | 7.00          | 8.05          | 9.05          | 7.80          | 7.61          | 8.85          | 9.64          | 8.55          | 8.20          | 9.21          | 9.97  |
|  | kW                                    | 0.76          | 0.76          | 0.77          | 0.78          | 0.77          | 0.77          | 0.78          | 0.78          | 0.78          | 0.78          | 0.78          | 0.78  |
|  | CMP                                   | 0.66          | 0.67          | 0.68          | 0.69          | 0.67          | 0.67          | 0.68          | 0.69          | 0.68          | 0.68          | 0.69          | 0.69  |
|  | LDB                                   | 47.5          | 49.8          | 54.4          | 58.8          | 52.6          | 54.4          | 58.3          | 62.7          | 56.0          | 57.0          | 60.9          | 65.2  |
|  | LWB                                   | 42.8          | 48.9          | 53.3          | 58.1          | 45.3          | 51.7          | 56.2          | 61.4          | 46.9          | 53.3          | 58.2          | 63.4  |
|  | TCG                                   | 6.40          | 6.54          | 7.59          | 8.70          | 7.39          | 7.09          | 8.26          | 9.20          | 8.10          | 8.10          | 8.73          | 9.56  |
| 115<br>(46.11)                                     | SHG                                   | 6.40          | 6.19          | 5.28          | 4.40          | 7.39          | 7.09          | 6.11          | 4.86          | 8.10          | 8.10          | 6.74          | 5.26  |
|  | TC                                    | 6.39          | 6.53          | 7.58          | 8.69          | 7.38          | 7.07          | 8.25          | 9.19          | 8.08          | 8.09          | 8.72          | 9.54  |
|  | kW                                    | 0.84          | 0.85          | 0.86          | 0.87          | 0.86          | 0.85          | 0.87          | 0.87          | 0.86          | 0.86          | 0.87          | 0.87  |
|  | CMP                                   | 0.75          | 0.75          | 0.76          | 0.77          | 0.76          | 0.76          | 0.77          | 0.77          | 0.77          | 0.77          | 0.77          | 0.78  |
|  | LDB                                   | 49.6          | 50.6          | 55.0          | 59.4          | 54.0          | 55.0          | 58.6          | 63.1          | 57.3          | 57.3          | 61.2          | 65.4  |
|  | LWB                                   | 43.9          | 49.9          | 54.2          | 58.7          | 46.0          | 52.5          | 57.0          | 61.9          | 47.5          | 53.4          | 58.7          | 63.8  |
| 125<br>(51.67)                                     | TCG                                   | 5.87          | 5.81          | 7.03          | 8.09          | 6.91          | 6.91          | 7.64          | 8.67          | 7.59          | 7.59          | 8.01          | 8.99  |
|  | SHG                                   | 5.87          | 5.79          | 5.08          | 4.18          | 6.91          | 6.91          | 5.97          | 4.70          | 7.59          | 7.59          | 6.61          | 5.10  |
|  | TC                                    | 5.85          | 5.80          | 7.01          | 8.08          | 6.89          | 6.90          | 7.63          | 8.65          | 7.57          | 7.57          | 7.99          | 8.97  |
|  | kW                                    | 0.93          | 0.93          | 0.95          | 0.96          | 0.95          | 0.95          | 0.96          | 0.97          | 0.96          | 0.96          | 0.96          | 0.97  |
|  | CMP                                   | 0.83          | 0.83          | 0.85          | 0.86          | 0.85          | 0.85          | 0.86          | 0.87          | 0.86          | 0.86          | 0.86          | 0.87  |
|  | LDB                                   | 52.0          | 52.4          | 55.9          | 60.3          | 55.6          | 55.6          | 59.0          | 63.6          | 58.7          | 58.7          | 61.5          | 65.8  |
| 125<br>(51.67)                                     | LWB                                   | 45.0          | 51.3          | 55.2          | 59.7          | 46.7          | 52.8          | 57.8          | 62.5          | 48.1          | 54.0          | 59.4          | 64.3  |
|  | TCG                                   | 5.33          | 5.33          | 6.22          | 7.44          | 6.37          | 6.37          | 6.80          | 8.09          | 7.03          | 7.03          | 7.00          | 8.35  |
|  | SHG                                   | 5.33          | 5.33          | 4.75          | 3.96          | 6.37          | 6.37          | 5.71          | 4.54          | 7.03          | 7.03          | 6.31          | 4.96  |
|  | TC                                    | 5.31          | 5.31          | 6.21          | 7.42          | 6.35          | 6.35          | 6.78          | 8.07          | 7.02          | 7.02          | 6.99          | 8.33  |
|  | kW                                    | 1.03          | 1.03          | 1.04          | 1.06          | 1.04          | 1.04          | 1.05          | 1.07          | 1.05          | 1.05          | 1.05          | 1.07  |
|  | CMP                                   | 0.93          | 0.93          | 0.94          | 0.96          | 0.94          | 0.94          | 0.95          | 0.97          | 0.95          | 0.95          | 0.95          | 0.97  |
| LDB  | 54.4                                  | 54.5          | 57.3          | 61.3          | 57.5          | 57.5          | 59.8          | 64.1          | 60.2          | 60.2          | 62.2          | 66.2          |       |
| LWB  | 46.2                                  | 52.3          | 56.7          | 60.8          | 47.6          | 53.5          | 58.8          | 63.2          | 48.8          | 54.6          | 60.4          | 64.9          |       |

### LEGEND

BF – Bypass Factor  
 CMP – Compressor  
 Edb – Entering Dry Bulb  
 Ewb – Entering Wet Bulb  
 kW – Total Power  
 LDB – Leaving Dry Bulb  
 LWB – Leaving Wet Bulb  
 SHG – Gross Sensible Capacity (1000 Btu/hour)  
 TC – Total Net Cooling Capacity (1000 Btu/hour)  
 TCG – Gross Cooling Capacity (1000 Btu/hour)

### NOTES:

1. Direct interpolation is permissible. Do not extrapolate.
2. The SHG is based on 80°F (26.67°C) edb temperature of air entering indoor coil.  
 Below 80°F (26.67°C) edb, subtract (corr factor x cfm) from SHG.  
 Above 80°F (26.67°C) edb, add (corr factor x cfm) to SHG.  
 Correction Factor =  $1.10 \times (1 - BF) \times (edb - 80)$ .

# PERFORMANCE DATA (CONT.)

## COOLING CAPACITIES 38MVC(Q)012-1 / 40MVC(Q)012-1

| Temp °F (°C)<br>Air Entering<br>Condenser<br>(Edb) | Air Entering Evaporator – Cfm/BF      |            |            |            |            |            |            |            |            |            |            |            |       |
|--|---------------------------------------|------------|------------|------------|------------|------------|------------|------------|------------|------------|------------|------------|-------|
|  | 339/0.04                              |            |            |            | 367/0.04   |            |            |            | 427/0.05   |            |            |            |       |
|  | Air Entering Evaporator – Ewb °F (°C) |            |            |            |            |            |            |            |            |            |            |            |       |
|  | 57 (13.89)                            | 62 (16.67) | 67 (19.44) | 72 (22.22) | 57 (13.89) | 62 (16.67) | 67 (19.44) | 72 (22.22) | 57 (13.89) | 62 (16.67) | 67 (19.44) | 72 (22.22) |       |
| 55<br>(12.78)                                      | TCG                                   | 11.97      | 12.10      | 12.93      | 13.50      | 12.26      | 12.28      | 13.10      | 13.60      | 12.71      | 12.61      | 13.33      | 13.76 |
|  | SHG                                   | 11.97      | 9.93       | 8.34       | 6.68       | 12.26      | 10.27      | 8.58       | 6.77       | 12.71      | 10.96      | 8.95       | 6.97  |
|  | TC                                    | 11.94      | 12.07      | 12.90      | 13.47      | 12.23      | 12.25      | 13.07      | 13.57      | 12.68      | 12.58      | 13.30      | 13.74 |
|  | kW                                    | 0.63       | 0.63       | 0.62       | 0.62       | 0.63       | 0.63       | 0.62       | 0.62       | 0.62       | 0.62       | 0.62       | 0.62  |
|  | CMP                                   | 0.53       | 0.53       | 0.53       | 0.53       | 0.53       | 0.53       | 0.53       | 0.53       | 0.53       | 0.53       | 0.53       | 0.53  |
|  | LDB                                   | 48.2       | 53.5       | 57.8       | 62.4       | 49.8       | 54.6       | 58.9       | 63.5       | 53.0       | 56.6       | 61.0       | 65.3  |
| 65<br>(18.33)                                      | LWB                                   | 43.2       | 49.4       | 54.8       | 60.6       | 44.0       | 50.2       | 55.7       | 61.4       | 45.5       | 51.7       | 57.2       | 62.9  |
|  | TCG                                   | 11.64      | 11.71      | 12.64      | 13.30      | 11.94      | 11.91      | 12.79      | 13.37      | 12.44      | 12.25      | 13.07      | 13.52 |
|  | SHG                                   | 11.64      | 9.78       | 8.27       | 6.66       | 11.94      | 10.15      | 8.49       | 6.73       | 12.44      | 10.95      | 9.02       | 6.90  |
|  | TC                                    | 11.61      | 11.68      | 12.61      | 13.27      | 11.91      | 11.88      | 12.76      | 13.34      | 12.41      | 12.22      | 13.04      | 13.49 |
|  | kW                                    | 0.72       | 0.72       | 0.72       | 0.72       | 0.72       | 0.72       | 0.72       | 0.72       | 0.72       | 0.72       | 0.72       | 0.72  |
|  | CMP                                   | 0.62       | 0.62       | 0.62       | 0.62       | 0.62       | 0.62       | 0.62       | 0.62       | 0.62       | 0.62       | 0.62       | 0.62  |
| 75<br>(23.89)                                      | LDB                                   | 49.0       | 53.9       | 58.0       | 62.4       | 50.6       | 54.9       | 59.1       | 63.5       | 53.5       | 56.6       | 60.8       | 65.4  |
|  | LWB                                   | 43.6       | 49.8       | 55.1       | 60.8       | 44.3       | 50.6       | 55.9       | 61.6       | 45.7       | 52.1       | 57.4       | 63.1  |
|  | TCG                                   | 11.28      | 11.27      | 12.27      | 13.00      | 11.56      | 11.45      | 12.43      | 13.12      | 12.07      | 11.48      | 12.70      | 13.25 |
|  | SHG                                   | 11.28      | 9.63       | 8.15       | 6.61       | 11.56      | 9.92       | 8.47       | 6.75       | 12.07      | 10.16      | 8.94       | 6.89  |
|  | TC                                    | 11.25      | 11.24      | 12.24      | 12.97      | 11.53      | 11.43      | 12.40      | 13.09      | 12.04      | 11.46      | 12.67      | 13.23 |
|  | kW                                    | 0.81       | 0.81       | 0.82       | 0.82       | 0.81       | 0.81       | 0.82       | 0.82       | 0.82       | 0.82       | 0.82       | 0.82  |
| 85<br>(29.44)                                      | CMP                                   | 0.71       | 0.71       | 0.71       | 0.72       | 0.71       | 0.71       | 0.71       | 0.72       | 0.71       | 0.71       | 0.71       | 0.72  |
|  | LDB                                   | 49.9       | 54.3       | 58.3       | 62.5       | 51.5       | 55.5       | 59.1       | 63.5       | 54.3       | 58.3       | 60.9       | 65.4  |
|  | LWB                                   | 44.0       | 50.3       | 55.5       | 61.1       | 44.8       | 51.2       | 56.3       | 61.9       | 46.1       | 52.7       | 57.7       | 63.3  |
|  | TCG                                   | 10.79      | 10.76      | 11.78      | 12.63      | 11.12      | 10.68      | 11.96      | 12.76      | 11.63      | 11.29      | 12.24      | 12.93 |
|  | SHG                                   | 10.79      | 9.24       | 7.98       | 6.49       | 11.12      | 9.50       | 8.25       | 6.64       | 11.63      | 10.62      | 8.81       | 6.89  |
|  | TC                                    | 10.76      | 10.73      | 11.76      | 12.60      | 11.09      | 10.65      | 11.93      | 12.73      | 11.60      | 11.27      | 12.21      | 12.91 |
| 95<br>(35)   | kW                                    | 0.91       | 0.91       | 0.92       | 0.92       | 0.92       | 0.91       | 0.92       | 0.93       | 0.92       | 0.92       | 0.92       | 0.93  |
|  | CMP                                   | 0.81       | 0.81       | 0.82       | 0.82       | 0.81       | 0.81       | 0.82       | 0.82       | 0.82       | 0.82       | 0.82       | 0.82  |
|  | LDB                                   | 51.2       | 55.3       | 58.7       | 62.8       | 52.5       | 56.4       | 59.6       | 63.7       | 55.2       | 57.3       | 61.2       | 65.4  |
|  | LWB                                   | 44.6       | 51.5       | 56.0       | 61.4       | 45.3       | 52.0       | 56.7       | 62.2       | 46.5       | 52.8       | 58.0       | 63.5  |
|  | TCG                                   | 10.17      | 9.76       | 11.21      | 12.15      | 10.55      | 10.05      | 11.37      | 12.27      | 11.12      | 11.12      | 11.66      | 12.49 |
|  | SHG                                   | 10.17      | 9.14       | 7.81       | 6.32       | 10.55      | 9.50       | 8.08       | 6.47       | 11.12      | 11.12      | 8.64       | 6.79  |
| 105<br>(40.56)                                     | TC                                    | 10.14      | 9.73       | 11.18      | 12.12      | 10.53      | 10.02      | 11.34      | 12.24      | 11.09      | 11.09      | 11.63      | 12.46 |
|  | kW                                    | 1.02       | 1.01       | 1.03       | 1.04       | 1.02       | 1.02       | 1.03       | 1.04       | 1.03       | 1.03       | 1.03       | 1.04  |
|  | CMP                                   | 0.91       | 0.91       | 0.92       | 0.93       | 0.92       | 0.91       | 0.92       | 0.93       | 0.92       | 0.92       | 0.93       | 0.93  |
|  | LDB                                   | 52.7       | 55.4       | 59.1       | 63.2       | 53.8       | 56.4       | 60.0       | 64.1       | 56.2       | 56.2       | 61.5       | 65.6  |
|  | LWB                                   | 45.4       | 52.0       | 56.6       | 61.8       | 45.9       | 52.5       | 57.3       | 62.6       | 47.0       | 53.0       | 58.5       | 63.8  |
|  | TCG                                   | 9.51       | 8.95       | 10.54      | 11.55      | 9.87       | 9.86       | 10.70      | 11.68      | 10.54      | 10.55      | 10.96      | 11.88 |
| 115<br>(46.11)                                     | SHG                                   | 9.51       | 8.73       | 7.59       | 6.12       | 9.87       | 9.86       | 7.88       | 6.28       | 10.54      | 10.55      | 8.44       | 6.60  |
|  | TC                                    | 9.48       | 8.92       | 10.51      | 11.52      | 9.84       | 9.84       | 10.68      | 11.65      | 10.52      | 10.52      | 10.93      | 11.85 |
|  | kW                                    | 1.13       | 1.12       | 1.14       | 1.15       | 1.13       | 1.13       | 1.14       | 1.15       | 1.14       | 1.14       | 1.15       | 1.16  |
|  | CMP                                   | 1.02       | 1.01       | 1.04       | 1.05       | 1.03       | 1.03       | 1.04       | 1.05       | 1.04       | 1.04       | 1.04       | 1.05  |
|  | LDB                                   | 54.4       | 56.5       | 59.7       | 63.7       | 55.5       | 55.5       | 60.4       | 64.6       | 57.4       | 57.4       | 61.9       | 66.0  |
|  | LWB                                   | 46.2       | 52.9       | 57.2       | 62.4       | 46.7       | 52.7       | 57.9       | 63.1       | 47.5       | 53.5       | 59.0       | 64.2  |
| 125<br>(51.67)                                     | TCG                                   | 8.82       | 8.82       | 9.56       | 10.82      | 9.16       | 9.16       | 9.82       | 10.96      | 9.81       | 9.81       | 10.17      | 11.16 |
|  | SHG                                   | 8.82       | 8.82       | 7.29       | 5.87       | 9.16       | 9.16       | 7.61       | 6.04       | 9.81       | 9.81       | 8.21       | 6.37  |
|  | TC                                    | 8.79       | 8.79       | 9.53       | 10.79      | 9.13       | 9.13       | 9.80       | 10.93      | 9.78       | 9.78       | 10.14      | 11.13 |
|  | kW                                    | 1.25       | 1.25       | 1.26       | 1.28       | 1.25       | 1.25       | 1.26       | 1.28       | 1.26       | 1.26       | 1.27       | 1.28  |
|  | CMP                                   | 1.14       | 1.14       | 1.15       | 1.17       | 1.14       | 1.14       | 1.15       | 1.17       | 1.15       | 1.15       | 1.16       | 1.17  |
|  | LDB                                   | 56.2       | 56.2       | 60.4       | 64.4       | 57.2       | 57.1       | 61.0       | 65.1       | 58.9       | 58.9       | 62.4       | 66.4  |
| 125<br>(51.67)                                     | LWB                                   | 47.0       | 53.0       | 58.2       | 63.0       | 47.4       | 53.4       | 58.7       | 63.6       | 48.2       | 54.1       | 59.6       | 64.7  |
|  | TCG                                   | 8.11       | 8.14       | 8.49       | 9.97       | 8.42       | 8.41       | 8.65       | 10.10      | 9.01       | 9.01       | 8.81       | 10.30 |
|  | SHG                                   | 8.11       | 8.14       | 6.97       | 5.59       | 8.42       | 8.41       | 7.18       | 5.77       | 9.01       | 9.01       | 7.63       | 6.11  |
|  | TC                                    | 8.08       | 8.11       | 8.46       | 9.94       | 8.39       | 8.38       | 8.63       | 10.07      | 8.99       | 8.98       | 8.78       | 10.27 |
|  | kW                                    | 1.37       | 1.37       | 1.37       | 1.40       | 1.37       | 1.37       | 1.38       | 1.40       | 1.39       | 1.39       | 1.38       | 1.41  |
|  | CMP                                   | 1.26       | 1.26       | 1.26       | 1.29       | 1.26       | 1.26       | 1.27       | 1.29       | 1.27       | 1.27       | 1.27       | 1.29  |
| 125<br>(51.67)                                     | LDB                                   | 58.1       | 58.0       | 61.2       | 65.1       | 58.9       | 58.9       | 62.1       | 65.7       | 60.5       | 60.6       | 63.5       | 66.9  |
|  | LWB                                   | 47.9       | 53.7       | 59.2       | 63.8       | 48.2       | 54.1       | 59.7       | 64.3       | 49.0       | 54.8       | 60.7       | 65.3  |

38/40MVC, MVQ

### LEGEND

- BF – Bypass Factor
- CMP – Compressor
- Edb – Entering Dry Bulb
- Ewb – Entering Wet Bulb
- kW – Total Power
- LDB – Leaving Dry Bulb
- LWB – Leaving Wet Bulb
- SHG – Gross Sensible Capacity (1000 Btu/hour)
- TC – Total Net Cooling Capacity (1000 Btu/hour)
- TCG – Gross Cooling Capacity (1000 Btu/hour)

### NOTES:

1. Direct interpolation is permissible. Do not extrapolate.
2. The SHG is based on 80°F (26.67°C) edb temperature of air entering indoor coil.  
Below 80°F (26.67°C) edb, subtract (corr factor x cfm) from SHG.  
Above 80°F (26.67°C) edb, add (corr factor x cfm) to SHG.  
Correction Factor = 1.10 x (1 – BF) x (edb – 80).

# PERFORMANCE DATA (CONT.)

## COOLING CAPACITIES 38MVC(Q)012-3 / 40MVC(Q)012-3

| Temp °F (°C)<br>Air Entering<br>Condenser<br>(Edb) | Air Entering Evaporator – Cfm/BF      |               |               |               |               |               |               |               |               |               |               |               |       |
|--|---------------------------------------|---------------|---------------|---------------|---------------|---------------|---------------|---------------|---------------|---------------|---------------|---------------|-------|
|  | 339/0.04                              |               |               |               | 367/0.04      |               |               |               | 427/0.05      |               |               |               |       |
|  | Air Entering Evaporator – Ewb °F (°C) |               |               |               |               |               |               |               |               |               |               |               |       |
|  | 57<br>(13.89)                         | 62<br>(16.67) | 67<br>(19.44) | 72<br>(22.22) | 57<br>(13.89) | 62<br>(16.67) | 67<br>(19.44) | 72<br>(22.22) | 57<br>(13.89) | 62<br>(16.67) | 67<br>(19.44) | 72<br>(22.22) |       |
| 55<br>(12.78)                                      | TCG                                   | 12.38         | 12.72         | 13.71         | 14.48         | 12.91         | 13.08         | 13.98         | 14.63         | 13.63         | 13.56         | 14.38         | 14.83 |
|  | SHG                                   | 12.38         | 10.09         | 8.66          | 7.11          | 12.91         | 10.63         | 8.99          | 7.21          | 13.63         | 11.61         | 9.59          | 7.45  |
|  | TC                                    | 12.35         | 12.69         | 13.69         | 14.45         | 12.88         | 13.05         | 13.95         | 14.61         | 13.60         | 13.53         | 14.35         | 14.81 |
|  | kW                                    | 0.64          | 0.63          | 0.63          | 0.63          | 0.63          | 0.63          | 0.63          | 0.63          | 0.63          | 0.63          | 0.63          | 0.63  |
|  | CMP                                   | 0.52          | 0.52          | 0.52          | 0.52          | 0.52          | 0.52          | 0.52          | 0.51          | 0.52          | 0.52          | 0.51          | 0.51  |
|  | LDB                                   | 45.1          | 51.4          | 55.6          | 60.1          | 47.6          | 53.2          | 57.4          | 62.0          | 51.6          | 55.7          | 60.0          | 64.6  |
| 65<br>(18.33)                                      | LWB                                   | 41.7          | 47.7          | 53.0          | 58.8          | 42.9          | 49.1          | 54.5          | 60.3          | 44.8          | 51.1          | 56.6          | 62.4  |
|  | TCG                                   | 12.04         | 12.30         | 13.35         | 14.17         | 12.55         | 12.65         | 13.68         | 14.38         | 13.30         | 13.15         | 14.06         | 14.58 |
|  | SHG                                   | 12.04         | 9.95          | 8.50          | 7.00          | 12.55         | 10.46         | 8.90          | 7.17          | 13.30         | 11.48         | 9.55          | 7.38  |
|  | TC                                    | 12.01         | 12.28         | 13.33         | 14.14         | 12.52         | 12.62         | 13.65         | 14.36         | 13.27         | 13.12         | 14.03         | 14.56 |
|  | kW                                    | 0.73          | 0.73          | 0.72          | 0.72          | 0.73          | 0.73          | 0.72          | 0.72          | 0.72          | 0.72          | 0.72          | 0.72  |
|  | CMP                                   | 0.61          | 0.61          | 0.61          | 0.61          | 0.61          | 0.61          | 0.61          | 0.61          | 0.61          | 0.61          | 0.61          | 0.61  |
| 75<br>(23.89)                                      | LDB                                   | 46.0          | 51.8          | 56.0          | 60.3          | 48.5          | 53.6          | 57.6          | 62.1          | 52.2          | 55.9          | 60.0          | 64.7  |
|  | LWB                                   | 42.1          | 48.2          | 53.5          | 59.1          | 43.3          | 49.5          | 54.8          | 60.5          | 45.1          | 51.4          | 56.8          | 62.5  |
|  | TCG                                   | 11.48         | 11.75         | 12.93         | 13.85         | 12.15         | 12.16         | 13.25         | 14.05         | 12.89         | 12.57         | 13.64         | 14.30 |
|  | SHG                                   | 11.48         | 9.73          | 8.43          | 6.93          | 12.15         | 10.29         | 8.78          | 7.09          | 12.89         | 11.07         | 9.44          | 7.34  |
|  | TC                                    | 11.46         | 11.72         | 12.90         | 13.83         | 12.12         | 12.13         | 13.22         | 14.03         | 12.86         | 12.55         | 13.62         | 14.27 |
|  | kW                                    | 0.82          | 0.82          | 0.82          | 0.83          | 0.82          | 0.82          | 0.82          | 0.83          | 0.82          | 0.82          | 0.82          | 0.83  |
| 85<br>(29.44)                                      | CMP                                   | 0.70          | 0.70          | 0.70          | 0.70          | 0.70          | 0.70          | 0.70          | 0.70          | 0.70          | 0.70          | 0.70          | 0.70  |
|  | LDB                                   | 47.5          | 52.4          | 56.1          | 60.5          | 49.4          | 54.0          | 57.9          | 62.3          | 53.0          | 56.5          | 60.3          | 64.8  |
|  | LWB                                   | 42.8          | 48.9          | 53.9          | 59.4          | 43.8          | 50.1          | 55.2          | 60.8          | 45.5          | 51.9          | 57.1          | 62.7  |
|  | TCG                                   | 10.89         | 10.97         | 12.39         | 13.42         | 11.57         | 11.40         | 12.74         | 13.65         | 12.42         | 12.09         | 13.14         | 13.94 |
|  | SHG                                   | 10.89         | 9.44          | 8.16          | 6.75          | 11.57         | 9.92          | 8.61          | 6.98          | 12.42         | 11.19         | 9.29          | 7.33  |
|  | TC                                    | 10.86         | 10.94         | 12.36         | 13.39         | 11.54         | 11.36         | 12.71         | 13.62         | 12.39         | 12.06         | 13.12         | 13.91 |
| 95<br>(35)   | kW                                    | 0.92          | 0.92          | 0.93          | 0.93          | 0.93          | 0.92          | 0.93          | 0.93          | 0.93          | 0.93          | 0.93          | 0.94  |
|  | CMP                                   | 0.79          | 0.79          | 0.80          | 0.81          | 0.80          | 0.80          | 0.80          | 0.81          | 0.80          | 0.80          | 0.80          | 0.81  |
|  | LDB                                   | 49.1          | 53.1          | 56.9          | 61.0          | 50.8          | 54.6          | 58.3          | 62.5          | 54.0          | 56.5          | 60.5          | 64.8  |
|  | LWB                                   | 43.6          | 49.8          | 54.5          | 59.8          | 44.5          | 50.9          | 55.7          | 61.2          | 46.0          | 52.3          | 57.5          | 63.0  |
|  | TCG                                   | 10.25         | 9.77          | 11.79         | 12.87         | 10.89         | 10.51         | 12.08         | 13.12         | 11.87         | 11.26         | 12.51         | 13.44 |
|  | SHG                                   | 10.25         | 8.87          | 7.95          | 6.55          | 10.89         | 9.81          | 8.37          | 6.79          | 11.87         | 10.76         | 9.11          | 7.21  |
| 105<br>(40.56)                                     | TC                                    | 10.22         | 9.74          | 11.76         | 12.84         | 10.86         | 10.48         | 12.05         | 13.09         | 11.84         | 11.23         | 12.48         | 13.41 |
|  | kW                                    | 1.02          | 1.02          | 1.04          | 1.05          | 1.03          | 1.03          | 1.04          | 1.05          | 1.04          | 1.04          | 1.04          | 1.05  |
|  | CMP                                   | 0.89          | 0.89          | 0.91          | 0.91          | 0.90          | 0.90          | 0.91          | 0.92          | 0.91          | 0.90          | 0.91          | 0.92  |
|  | LDB                                   | 50.8          | 54.6          | 57.4          | 61.5          | 52.4          | 55.1          | 58.8          | 63.0          | 55.1          | 57.3          | 60.9          | 65.0  |
|  | LWB                                   | 44.5          | 51.3          | 55.2          | 60.4          | 45.2          | 51.8          | 56.4          | 61.6          | 46.5          | 53.0          | 58.0          | 63.3  |
|  | TCG                                   | 9.62          | 9.12          | 10.90         | 12.18         | 10.20         | 9.65          | 11.40         | 12.46         | 11.19         | 11.20         | 11.77         | 12.78 |
| 115<br>(46.11)                                     | SHG                                   | 9.62          | 8.71          | 7.64          | 6.30          | 10.20         | 9.37          | 8.15          | 6.56          | 11.19         | 11.20         | 8.91          | 6.99  |
|  | TC                                    | 9.59          | 9.09          | 10.87         | 12.15         | 10.17         | 9.62          | 11.37         | 12.43         | 11.16         | 11.17         | 11.75         | 12.76 |
|  | kW                                    | 1.14          | 1.13          | 1.15          | 1.16          | 1.15          | 1.14          | 1.16          | 1.17          | 1.16          | 1.16          | 1.16          | 1.17  |
|  | CMP                                   | 1.00          | 0.99          | 1.02          | 1.03          | 1.01          | 1.00          | 1.02          | 1.03          | 1.02          | 1.02          | 1.02          | 1.03  |
|  | LDB                                   | 52.5          | 55.0          | 58.2          | 62.2          | 54.1          | 56.1          | 59.3          | 63.5          | 56.4          | 56.4          | 61.3          | 65.4  |
|  | LWB                                   | 45.3          | 52.0          | 56.2          | 61.1          | 46.0          | 52.7          | 57.0          | 62.2          | 47.1          | 53.1          | 58.6          | 63.8  |
| 125<br>(51.67)                                     | TCG                                   | 8.94          | 8.92          | 9.89          | 11.41         | 9.47          | 9.47          | 10.34         | 11.67         | 10.38         | 10.39         | 10.93         | 11.98 |
|  | SHG                                   | 8.94          | 8.92          | 7.31          | 6.02          | 9.47          | 9.47          | 7.81          | 6.29          | 10.38         | 10.39         | 8.66          | 6.73  |
|  | TC                                    | 8.91          | 8.90          | 9.86          | 11.38         | 9.44          | 9.44          | 10.31         | 11.65         | 10.35         | 10.37         | 10.90         | 11.95 |
|  | kW                                    | 1.26          | 1.26          | 1.27          | 1.29          | 1.27          | 1.27          | 1.28          | 1.29          | 1.28          | 1.28          | 1.28          | 1.29  |
|  | CMP                                   | 1.11          | 1.11          | 1.13          | 1.14          | 1.12          | 1.12          | 1.13          | 1.15          | 1.13          | 1.13          | 1.14          | 1.15  |
|  | LDB                                   | 54.4          | 54.4          | 59.1          | 62.9          | 55.9          | 55.9          | 60.1          | 64.1          | 58.1          | 58.0          | 61.7          | 65.9  |
| 125<br>(51.67)                                     | LWB                                   | 46.2          | 52.3          | 57.2          | 61.8          | 46.9          | 52.9          | 58.0          | 62.8          | 47.9          | 53.8          | 59.2          | 64.3  |
|  | TCG                                   | 8.21          | 8.21          | 8.79          | 10.52         | 8.70          | 8.71          | 9.17          | 10.76         | 9.54          | 9.54          | 9.49          | 11.07 |
|  | SHG                                   | 8.21          | 8.21          | 6.99          | 5.72          | 8.70          | 8.71          | 7.47          | 5.99          | 9.54          | 9.54          | 8.05          | 6.45  |
|  | TC                                    | 8.18          | 8.18          | 8.76          | 10.50         | 8.68          | 8.68          | 9.15          | 10.73         | 9.51          | 9.51          | 9.46          | 11.04 |
|  | kW                                    | 1.38          | 1.38          | 1.39          | 1.41          | 1.39          | 1.39          | 1.40          | 1.42          | 1.40          | 1.40          | 1.40          | 1.42  |
|  | CMP                                   | 1.23          | 1.23          | 1.24          | 1.26          | 1.24          | 1.24          | 1.25          | 1.27          | 1.25          | 1.25          | 1.25          | 1.27  |
| 125<br>(51.67)                                     | LDB                                   | 56.3          | 56.4          | 59.9          | 63.7          | 57.7          | 57.7          | 60.9          | 64.9          | 59.8          | 59.8          | 62.9          | 66.5  |
|  | LWB                                   | 47.1          | 53.1          | 58.4          | 62.7          | 47.7          | 53.7          | 59.1          | 63.6          | 48.6          | 54.5          | 60.3          | 64.9  |

### LEGEND

|     |  |
|-----|--|
| BF  | – Bypass Factor                              |
| CMP | – Compressor                                 |
| Edb | – Entering Dry Bulb                          |
| Ewb | – Entering Wet Bulb                          |
| kW  | – Total Power                                |
| LDB | – Leaving Dry Bulb                           |
| LWB | – Leaving Wet Bulb                           |
| SHG | – Gross Sensible Capacity (1000 Btu/hour)    |
| TC  | – Total Net Cooling Capacity (1000 Btu/hour) |
| TCG | – Gross Cooling Capacity (1000 Btu/hour)     |

### NOTES:

- Direct interpolation is permissible. Do not extrapolate.
- The SHG is based on 80°F (26.67°C) edb temperature of air entering indoor coil.  
Below 80°F (26.67°C) edb, subtract (corr factor x cfm) from SHG.  
Above 80°F (26.67°C) edb, add (corr factor x cfm) to SHG.  
Correction Factor = 1.10 x (1 – BF) x (edb – 80).

# PERFORMANCE DATA (CONT.)

## COOLING CAPACITIES 38MVC(Q)018-3 / 40MVC(Q)018-3

| Temp °F (°C)<br>Air Entering<br>Condenser<br>(Edb) | Air Entering Evaporator – Cfm/BF   |               |               |               |               |               |               |               |               |               |               |               |       |
|--|------------------------------------|---------------|---------------|---------------|---------------|---------------|---------------|---------------|---------------|---------------|---------------|---------------|-------|
|  | 502/0.04                           |               |               |               | 568/0.04      |               |               |               | 631/0.05      |               |               |               |       |
|  | Air Entering Evaporator – Ewb (°F) |               |               |               |               |               |               |               |               |               |               |               |       |
|  | 57<br>(13.89)                      | 62<br>(16.67) | 67<br>(19.44) | 72<br>(22.22) | 57<br>(13.89) | 62<br>(16.67) | 67<br>(19.44) | 72<br>(22.22) | 57<br>(13.89) | 62<br>(16.67) | 67<br>(19.44) | 72<br>(22.22) |       |
| 55<br>(12.78)                                      | TCG                                | 17.50         | 18.57         | 19.75         | 20.70         | 18.16         | 19.02         | 20.07         | 21.03         | 18.68         | 19.33         | 20.33         | 21.34 |
|  | SHG                                | 17.50         | 15.22         | 12.67         | 10.45         | 18.16         | 16.04         | 13.10         | 10.71         | 18.68         | 16.68         | 13.46         | 10.89 |
|  | TC                                 | 17.33         | 18.40         | 19.58         | 20.53         | 17.98         | 18.85         | 19.90         | 20.85         | 18.50         | 19.15         | 20.15         | 21.17 |
|  | kW                                 | 0.90          | 0.90          | 0.89          | 0.89          | 0.90          | 0.89          | 0.89          | 0.89          | 0.90          | 0.89          | 0.89          | 0.89  |
|  | CMP                                | 0.75          | 0.75          | 0.74          | 0.74          | 0.75          | 0.75          | 0.74          | 0.74          | 0.75          | 0.74          | 0.74          | 0.74  |
|  | LDB                                | 48.6          | 52.6          | 57.2          | 61.3          | 51.0          | 54.4          | 59.1          | 63.0          | 53.1          | 55.9          | 60.6          | 64.4  |
| 65<br>(18.33)                                      | LWB                                | 43.5          | 49.0          | 54.5          | 60.2          | 44.7          | 50.3          | 55.9          | 61.5          | 45.6          | 51.4          | 56.9          | 62.5  |
|  | TCG                                | 17.18         | 18.13         | 19.38         | 20.38         | 17.81         | 18.54         | 19.70         | 20.67         | 18.33         | 18.84         | 19.99         | 20.93 |
|  | SHG                                | 17.18         | 15.30         | 12.64         | 10.32         | 17.81         | 16.19         | 13.11         | 10.59         | 18.33         | 16.99         | 13.78         | 10.80 |
|  | TC                                 | 17.01         | 17.95         | 19.21         | 20.21         | 17.63         | 18.37         | 19.53         | 20.50         | 18.16         | 18.66         | 19.82         | 20.75 |
|  | kW                                 | 1.03          | 1.03          | 1.02          | 1.02          | 1.03          | 1.03          | 1.02          | 1.02          | 1.03          | 1.02          | 1.02          | 1.02  |
|  | CMP                                | 0.88          | 0.88          | 0.87          | 0.87          | 0.88          | 0.88          | 0.87          | 0.87          | 0.88          | 0.87          | 0.87          | 0.87  |
| 75<br>(23.89)                                      | LDB                                | 49.1          | 52.5          | 57.3          | 61.6          | 51.6          | 54.1          | 59.1          | 63.2          | 53.5          | 55.5          | 60.1          | 64.5  |
|  | LWB                                | 43.8          | 49.3          | 54.7          | 60.4          | 44.9          | 50.6          | 56.1          | 61.7          | 45.9          | 51.7          | 57.1          | 62.7  |
|  | TCG                                | 16.66         | 17.56         | 18.85         | 19.97         | 17.39         | 17.91         | 19.22         | 20.23         | 17.89         | 18.25         | 19.48         | 20.46 |
|  | SHG                                | 16.66         | 15.36         | 12.54         | 10.15         | 17.39         | 16.30         | 13.20         | 10.45         | 17.89         | 17.20         | 13.59         | 10.68 |
|  | TC                                 | 16.48         | 17.39         | 18.68         | 19.79         | 17.21         | 17.74         | 19.04         | 20.06         | 17.71         | 18.08         | 19.31         | 20.28 |
|  | kW                                 | 1.16          | 1.16          | 1.16          | 1.16          | 1.16          | 1.16          | 1.16          | 1.16          | 1.16          | 1.16          | 1.16          | 1.16  |
| 85<br>(29.44)                                      | CMP                                | 1.01          | 1.01          | 1.01          | 1.01          | 1.02          | 1.01          | 1.01          | 1.01          | 1.01          | 1.01          | 1.01          | 1.01  |
|  | LDB                                | 50.0          | 52.3          | 57.4          | 61.9          | 52.2          | 53.9          | 58.9          | 63.4          | 54.1          | 55.1          | 60.4          | 64.7  |
|  | LWB                                | 44.2          | 49.8          | 55.1          | 60.7          | 45.2          | 51.1          | 56.4          | 62.0          | 46.1          | 52.0          | 57.4          | 62.9  |
|  | TCG                                | 16.06         | 16.69         | 18.22         | 19.41         | 16.78         | 17.24         | 18.54         | 19.69         | 17.37         | 17.56         | 18.82         | 19.90 |
|  | SHG                                | 16.06         | 15.39         | 12.45         | 10.01         | 16.78         | 16.41         | 13.04         | 10.34         | 17.37         | 16.93         | 13.61         | 10.59 |
|  | TC                                 | 15.89         | 16.52         | 18.05         | 19.24         | 16.60         | 17.06         | 18.37         | 19.51         | 17.19         | 17.39         | 18.64         | 19.72 |
| 95<br>(35)   | kW                                 | 1.30          | 1.30          | 1.31          | 1.31          | 1.30          | 1.31          | 1.31          | 1.31          | 1.31          | 1.31          | 1.31          | 1.32  |
|  | CMP                                | 1.15          | 1.15          | 1.16          | 1.16          | 1.16          | 1.16          | 1.16          | 1.17          | 1.16          | 1.16          | 1.16          | 1.17  |
|  | LDB                                | 51.0          | 52.2          | 57.6          | 62.1          | 53.1          | 53.7          | 59.1          | 63.6          | 54.9          | 55.5          | 60.3          | 64.8  |
|  | LWB                                | 44.7          | 50.4          | 55.6          | 61.0          | 45.7          | 51.5          | 56.8          | 62.3          | 46.5          | 52.4          | 57.7          | 63.2  |
|  | TCG                                | 15.33         | 15.64         | 17.37         | 18.64         | 15.99         | 16.15         | 17.74         | 18.97         | 16.60         | 16.51         | 18.00         | 19.18 |
|  | SHG                                | 15.33         | 15.05         | 12.28         | 9.75          | 15.99         | 15.76         | 12.96         | 10.13         | 16.60         | 16.51         | 13.54         | 10.43 |
| 105<br>(40.56)                                     | TC                                 | 15.16         | 15.47         | 17.20         | 18.46         | 15.81         | 15.98         | 17.57         | 18.80         | 16.43         | 16.34         | 17.83         | 19.00 |
|  | kW                                 | 1.45          | 1.45          | 1.47          | 1.47          | 1.45          | 1.46          | 1.47          | 1.47          | 1.46          | 1.46          | 1.47          | 1.47  |
|  | CMP                                | 1.30          | 1.30          | 1.32          | 1.32          | 1.31          | 1.31          | 1.32          | 1.32          | 1.31          | 1.31          | 1.32          | 1.33  |
|  | LDB                                | 52.2          | 52.8          | 57.8          | 62.5          | 54.3          | 54.7          | 59.2          | 63.9          | 55.9          | 56.1          | 60.4          | 65.0  |
|  | LWB                                | 45.3          | 51.2          | 56.1          | 61.5          | 46.2          | 52.2          | 57.3          | 62.7          | 47.0          | 53.0          | 58.2          | 63.5  |
|  | TCG                                | 14.49         | 14.46         | 16.37         | 17.74         | 15.13         | 15.14         | 16.71         | 18.04         | 15.67         | 15.69         | 16.97         | 18.28 |
| 115<br>(46.11)                                     | SHG                                | 14.49         | 14.46         | 12.11         | 9.47          | 15.13         | 15.14         | 12.81         | 9.86          | 15.67         | 15.69         | 13.44         | 10.21 |
|  | TC                                 | 14.32         | 14.29         | 16.19         | 17.57         | 14.96         | 14.96         | 16.54         | 17.87         | 15.49         | 15.52         | 16.80         | 18.10 |
|  | kW                                 | 1.61          | 1.61          | 1.63          | 1.64          | 1.61          | 1.61          | 1.63          | 1.64          | 1.62          | 1.62          | 1.63          | 1.64  |
|  | CMP                                | 1.46          | 1.46          | 1.48          | 1.49          | 1.46          | 1.46          | 1.48          | 1.49          | 1.47          | 1.47          | 1.48          | 1.49  |
|  | LDB                                | 53.7          | 53.8          | 58.1          | 63.0          | 55.6          | 55.6          | 59.4          | 64.3          | 57.2          | 57.2          | 60.5          | 65.3  |
|  | LWB                                | 46.0          | 52.1          | 56.8          | 62.1          | 46.9          | 52.9          | 57.9          | 63.1          | 47.6          | 53.5          | 58.7          | 64.0  |
| 125<br>(51.67)                                     | TCG                                | 13.45         | 13.45         | 14.96         | 16.66         | 14.13         | 14.13         | 15.41         | 16.94         | 14.65         | 14.66         | 15.73         | 17.15 |
|  | SHG                                | 13.45         | 13.45         | 11.82         | 9.20          | 14.13         | 14.13         | 12.59         | 9.61          | 14.65         | 14.66         | 13.25         | 9.98  |
|  | TC                                 | 13.27         | 13.27         | 14.79         | 16.48         | 13.95         | 13.96         | 15.24         | 16.77         | 14.48         | 14.48         | 15.56         | 16.97 |
|  | kW                                 | 1.77          | 1.77          | 1.79          | 1.81          | 1.78          | 1.78          | 1.80          | 1.81          | 1.79          | 1.79          | 1.80          | 1.82  |
|  | CMP                                | 1.62          | 1.62          | 1.64          | 1.66          | 1.63          | 1.63          | 1.65          | 1.67          | 1.64          | 1.64          | 1.65          | 1.67  |
|  | LDB                                | 55.5          | 55.5          | 58.5          | 63.4          | 57.2          | 57.2          | 59.7          | 64.6          | 58.6          | 58.6          | 60.7          | 65.6  |
| 125<br>(51.67)                                     | LWB                                | 46.8          | 52.8          | 57.8          | 62.7          | 47.6          | 53.5          | 58.6          | 63.7          | 48.2          | 54.1          | 59.3          | 64.5  |
|  | TCG                                | 12.22         | 12.22         | 13.26         | 15.35         | 12.92         | 12.93         | 13.66         | 15.60         | 13.46         | 13.48         | 14.02         | 15.79 |
|  | SHG                                | 12.22         | 12.22         | 11.26         | 8.82          | 12.92         | 12.93         | 12.20         | 9.26          | 13.46         | 13.48         | 12.95         | 9.66  |
|  | TC                                 | 12.05         | 12.05         | 13.09         | 15.17         | 12.74         | 12.76         | 13.48         | 15.43         | 13.29         | 13.30         | 13.84         | 15.62 |
|  | kW                                 | 1.95          | 1.95          | 1.96          | 1.99          | 1.96          | 1.96          | 1.97          | 1.99          | 1.97          | 1.96          | 1.97          | 1.99  |
|  | CMP                                | 1.80          | 1.80          | 1.81          | 1.84          | 1.81          | 1.81          | 1.82          | 1.84          | 1.82          | 1.82          | 1.82          | 1.85  |
| 125<br>(51.67)                                     | LDB                                | 57.6          | 57.7          | 59.5          | 64.1          | 59.1          | 59.0          | 60.3          | 65.1          | 60.3          | 60.3          | 61.1          | 66.0  |
|  | LWB                                | 47.8          | 53.7          | 58.9          | 63.5          | 48.4          | 54.3          | 59.6          | 64.4          | 49.0          | 54.8          | 60.2          | 65.1  |

38/40MVC, MVQ

### LEGEND

- BF – Bypass Factor
- CMP – Compressor
- Edb – Entering Dry Bulb
- Ewb – Entering Wet Bulb
- kW – Total Power
- LDB – Leaving Dry Bulb
- LWB – Leaving Wet Bulb
- SHG – Gross Sensible Capacity (1000 Btu/hour)
- TC – Total Net Cooling Capacity (1000 Btu/hour)
- TCG – Gross Cooling Capacity (1000 Btu/hour)

### NOTES:

1. Direct interpolation is permissible. Do not extrapolate.
2. The SHG is based on 80°F (26.67°C) edb temperature of air entering indoor coil.  
Below 80°F (26.67°C) edb, subtract (corr factor x cfm) from SHG.  
Above 80°F (26.67°C) edb, add (corr factor x cfm) to SHG.  
Correction Factor = 1.10 x (1 – BF) x (edb – 80).

# PERFORMANCE DATA (CONT.)

## COOLING CAPACITIES 38MVC(Q)024-3 / 40MVC(Q)024-3

| Temp °F (°C)<br>Air Entering<br>Condenser<br>(Edb) | Air Entering Evaporator – Cfm/BF   |       |       |       |          |       |       |       |          |       |       |       |       |
|--|------------------------------------|-------|-------|-------|----------|-------|-------|-------|----------|-------|-------|-------|-------|
|  | 584/0.04                           |       |       |       | 657/0.04 |       |       |       | 759/0.05 |       |       |       |       |
|  | Air Entering Evaporator – Ewb (°F) |       |       |       |          |       |       |       |          |       |       |       |       |
|  | 57                                 | 62    | 67    | 72    | 57       | 62    | 67    | 72    | 57       | 62    | 67    | 72    |       |
| 55<br>(12.78)                                      | TCG                                | 21.41 | 23.09 | 24.52 | 25.73    | 22.21 | 23.60 | 24.95 | 26.13    | 23.21 | 24.19 | 25.43 | 26.63 |
|  | SHG                                | 21.41 | 18.42 | 15.56 | 12.83    | 22.21 | 19.37 | 16.10 | 13.17    | 23.21 | 20.61 | 16.74 | 13.53 |
|  | TC                                 | 21.10 | 22.78 | 24.21 | 25.42    | 21.91 | 23.29 | 24.64 | 25.82    | 22.91 | 23.88 | 25.12 | 26.32 |
|  | kW                                 | 1.23  | 1.23  | 1.22  | 1.22     | 1.23  | 1.23  | 1.22  | 1.22     | 1.23  | 1.22  | 1.22  | 1.22  |
|  | CMP                                | 1.00  | 1.00  | 1.00  | 1.00     | 1.00  | 1.00  | 1.00  | 0.99     | 1.00  | 1.00  | 0.99  | 0.99  |
|  | LDB                                | 46.7  | 51.3  | 55.8  | 60.1     | 49.1  | 53.0  | 57.6  | 61.8     | 51.9  | 55.0  | 59.8  | 63.8  |
| 65<br>(18.33)                                      | LWB                                | 42.7  | 48.0  | 53.6  | 59.4     | 43.9  | 49.4  | 55.0  | 60.7     | 45.2  | 50.9  | 56.5  | 62.1  |
|  | TCG                                | 20.89 | 22.42 | 23.92 | 25.12    | 21.77 | 22.95 | 24.38 | 25.61    | 22.68 | 23.50 | 24.86 | 26.02 |
|  | SHG                                | 20.89 | 18.27 | 15.39 | 12.56    | 21.77 | 19.25 | 15.99 | 12.97    | 22.68 | 20.50 | 16.84 | 13.39 |
|  | TC                                 | 20.58 | 22.11 | 23.61 | 24.81    | 21.46 | 22.64 | 24.07 | 25.30    | 22.37 | 23.19 | 24.55 | 25.71 |
|  | kW                                 | 1.38  | 1.39  | 1.39  | 1.39     | 1.39  | 1.39  | 1.39  | 1.39     | 1.39  | 1.39  | 1.39  | 1.39  |
|  | CMP                                | 1.15  | 1.16  | 1.16  | 1.16     | 1.16  | 1.16  | 1.16  | 1.16     | 1.16  | 1.16  | 1.16  | 1.16  |
| 75<br>(23.89)                                      | LDB                                | 47.4  | 51.5  | 56.0  | 60.5     | 49.7  | 53.2  | 57.8  | 62.1     | 52.5  | 55.1  | 59.6  | 63.9  |
|  | LWB                                | 43.1  | 48.4  | 53.9  | 59.7     | 44.2  | 49.8  | 55.3  | 60.9     | 45.5  | 51.2  | 56.7  | 62.4  |
|  | TCG                                | 20.21 | 21.66 | 23.21 | 24.61    | 21.15 | 22.15 | 23.67 | 24.95    | 22.04 | 22.71 | 24.13 | 25.32 |
|  | SHG                                | 20.21 | 18.13 | 15.13 | 12.37    | 21.15 | 19.10 | 15.83 | 12.75    | 22.04 | 20.44 | 16.61 | 13.19 |
|  | TC                                 | 19.90 | 21.35 | 22.90 | 24.30    | 20.84 | 21.85 | 23.36 | 24.64    | 21.74 | 22.40 | 23.82 | 25.01 |
|  | kW                                 | 1.55  | 1.56  | 1.56  | 1.57     | 1.56  | 1.56  | 1.57  | 1.57     | 1.56  | 1.56  | 1.57  | 1.57  |
| 85<br>(29.44)                                      | CMP                                | 1.32  | 1.33  | 1.34  | 1.34     | 1.33  | 1.33  | 1.34  | 1.34     | 1.33  | 1.33  | 1.34  | 1.34  |
|  | LDB                                | 48.4  | 51.7  | 56.4  | 60.8     | 50.5  | 53.3  | 58.0  | 62.4     | 53.2  | 55.2  | 59.9  | 64.1  |
|  | LWB                                | 43.6  | 49.0  | 54.4  | 60.0     | 44.6  | 50.2  | 55.6  | 61.3     | 45.9  | 51.6  | 57.1  | 62.7  |
|  | TCG                                | 19.48 | 20.73 | 22.38 | 23.82    | 20.35 | 21.24 | 22.82 | 24.16    | 21.31 | 21.75 | 23.29 | 24.50 |
|  | SHG                                | 19.48 | 17.94 | 14.91 | 12.08    | 20.35 | 18.95 | 15.60 | 12.47    | 21.31 | 20.59 | 16.45 | 12.90 |
|  | TC                                 | 19.17 | 20.42 | 22.07 | 23.51    | 20.04 | 20.94 | 22.51 | 23.85    | 21.00 | 21.44 | 22.98 | 24.20 |
| 95<br>(35)   | kW                                 | 1.72  | 1.74  | 1.75  | 1.76     | 1.73  | 1.74  | 1.75  | 1.76     | 1.74  | 1.74  | 1.75  | 1.76  |
|  | CMP                                | 1.49  | 1.51  | 1.52  | 1.53     | 1.50  | 1.51  | 1.52  | 1.53     | 1.51  | 1.52  | 1.53  | 1.53  |
|  | LDB                                | 49.5  | 51.9  | 56.7  | 61.2     | 51.6  | 53.5  | 58.2  | 62.7     | 54.1  | 55.0  | 60.0  | 64.5  |
|  | LWB                                | 44.1  | 49.6  | 54.9  | 60.4     | 45.1  | 50.8  | 56.1  | 61.6     | 46.3  | 52.1  | 57.4  | 63.0  |
|  | TCG                                | 18.65 | 19.49 | 21.39 | 22.87    | 19.47 | 20.11 | 21.81 | 23.21    | 20.47 | 20.70 | 22.25 | 23.56 |
|  | SHG                                | 18.65 | 17.94 | 14.65 | 11.76    | 19.47 | 19.09 | 15.32 | 12.14    | 20.47 | 19.99 | 16.23 | 12.61 |
| 105<br>(40.56)                                     | TC                                 | 18.35 | 19.18 | 21.08 | 22.56    | 19.16 | 19.81 | 21.50 | 22.91    | 20.16 | 20.39 | 21.94 | 23.25 |
|  | kW                                 | 1.91  | 1.92  | 1.94  | 1.95     | 1.92  | 1.93  | 1.94  | 1.96     | 1.93  | 1.94  | 1.95  | 1.96  |
|  | CMP                                | 1.68  | 1.69  | 1.71  | 1.73     | 1.69  | 1.70  | 1.72  | 1.73     | 1.70  | 1.71  | 1.72  | 1.73  |
|  | LDB                                | 50.7  | 51.9  | 57.1  | 61.7     | 52.7  | 53.3  | 58.6  | 63.1     | 55.1  | 55.7  | 60.3  | 64.8  |
|  | LWB                                | 44.7  | 50.4  | 55.5  | 60.9     | 45.6  | 51.4  | 56.6  | 62.1     | 46.7  | 52.6  | 57.9  | 63.4  |
|  | TCG                                | 17.81 | 18.14 | 20.24 | 21.73    | 18.51 | 18.71 | 20.65 | 22.09    | 19.45 | 19.31 | 21.06 | 22.41 |
| 115<br>(46.11)                                     | SHG                                | 17.81 | 17.46 | 14.30 | 11.33    | 18.51 | 18.23 | 15.04 | 11.77    | 19.45 | 19.31 | 15.98 | 12.26 |
|  | TC                                 | 17.50 | 17.83 | 19.94 | 21.42    | 18.20 | 18.40 | 20.34 | 21.78    | 19.14 | 19.01 | 20.76 | 22.10 |
|  | kW                                 | 2.11  | 2.11  | 2.14  | 2.16     | 2.12  | 2.12  | 2.15  | 2.16     | 2.13  | 2.13  | 2.15  | 2.17  |
|  | CMP                                | 1.88  | 1.88  | 1.91  | 1.93     | 1.89  | 1.89  | 1.92  | 1.94     | 1.91  | 1.90  | 1.92  | 1.94  |
|  | LDB                                | 52.0  | 52.5  | 57.5  | 62.3     | 54.0  | 54.4  | 58.9  | 63.6     | 56.3  | 56.4  | 60.5  | 65.2  |
|  | LWB                                | 45.3  | 51.3  | 56.1  | 61.5     | 46.2  | 52.2  | 57.2  | 62.6     | 47.3  | 53.3  | 58.4  | 63.8  |
| 125<br>(51.67)                                     | TCG                                | 16.73 | 16.67 | 18.93 | 20.40    | 17.42 | 17.43 | 19.28 | 20.74    | 18.31 | 18.33 | 19.67 | 21.05 |
|  | SHG                                | 16.73 | 16.67 | 13.90 | 10.86    | 17.42 | 17.43 | 14.66 | 11.30    | 18.31 | 18.33 | 15.64 | 11.81 |
|  | TC                                 | 16.42 | 16.37 | 18.62 | 20.09    | 17.11 | 17.12 | 18.98 | 20.44    | 18.00 | 18.02 | 19.36 | 20.74 |
|  | kW                                 | 2.32  | 2.32  | 2.35  | 2.37     | 2.33  | 2.33  | 2.36  | 2.38     | 2.34  | 2.34  | 2.36  | 2.38  |
|  | CMP                                | 2.09  | 2.09  | 2.12  | 2.14     | 2.10  | 2.10  | 2.13  | 2.15     | 2.11  | 2.11  | 2.13  | 2.15  |
|  | LDB                                | 53.6  | 53.7  | 58.1  | 63.0     | 55.5  | 55.5  | 59.4  | 64.2     | 57.6  | 57.6  | 60.9  | 65.7  |
| 125<br>(51.67)                                     | LWB                                | 46.1  | 52.2  | 56.9  | 62.2     | 46.9  | 52.9  | 57.9  | 63.2     | 47.9  | 53.8  | 59.0  | 64.4  |
|  | TCG                                | 15.61 | 15.61 | 17.39 | 18.89    | 16.27 | 16.27 | 17.73 | 19.19    | 17.06 | 17.09 | 18.07 | 19.47 |
|  | SHG                                | 15.61 | 15.61 | 13.42 | 10.33    | 16.27 | 16.27 | 14.19 | 10.77    | 17.06 | 17.09 | 15.18 | 11.29 |
|  | TC                                 | 15.30 | 15.30 | 17.08 | 18.58    | 15.96 | 15.96 | 17.43 | 18.88    | 16.75 | 16.78 | 17.77 | 19.16 |
|  | kW                                 | 2.53  | 2.53  | 2.56  | 2.59     | 2.54  | 2.54  | 2.57  | 2.59     | 2.56  | 2.56  | 2.57  | 2.60  |
|  | CMP                                | 2.30  | 2.30  | 2.33  | 2.36     | 2.32  | 2.32  | 2.34  | 2.37     | 2.33  | 2.33  | 2.35  | 2.37  |
| 125<br>(51.67)                                     | LDB                                | 55.3  | 55.3  | 58.8  | 63.8     | 57.0  | 57.0  | 60.0  | 64.9     | 59.1  | 59.0  | 61.4  | 66.3  |
|  | LWB                                | 46.9  | 52.9  | 57.8  | 63.0     | 47.6  | 53.6  | 58.7  | 63.9     | 48.5  | 54.4  | 59.7  | 65.0  |

### LEGEND

BF – Bypass Factor  
 CMP – Compressor  
 Edb – Entering Dry Bulb  
 Ewb – Entering Wet Bulb  
 kW – Total Power  
 LDB – Leaving Dry Bulb  
 LWB – Leaving Wet Bulb  
 SHG – Gross Sensible Capacity (1000 Btu/hour)  
 TC – Total Net Cooling Capacity (1000 Btu/hour)  
 TCG – Gross Cooling Capacity (1000 Btu/hour)

### NOTES:

- Direct interpolation is permissible. Do not extrapolate.
- The SHG is based on 80°F (26.67°C) edb temperature of air entering indoor coil.  
 Below 80°F (26.67°C) edb, subtract (corr factor x cfm) from SHG.  
 Above 80°F (26.67°C) edb, add (corr factor x cfm) to SHG.  
 Correction Factor = 1.10 x (1 – BF) x (edb – 80).

# PERFORMANCE DATA (CONT.)

## INSTANTANEOUS AND INTEGRATED HEATING RATINGS 38MVQ009-1 / 40MVQ009-1

| Air Temperature Entering Indoor Unit °F (°C) | Indoor Airflow (CFM) L-M-H | Item   | Air Temperature Entering Outdoor Coil – DB/WB °F (°C) |                   |                 |                   |                 |                   |                   |                   |                 |                   |                 |                   |                      |      |      |
|--|----------------------------|--------|---|-------------------|-----------------|-------------------|-----------------|-------------------|-------------------|-------------------|-----------------|-------------------|-----------------|-------------------|----------------------|------|------|
|  |                            |        | 57/53 (13.89/11.67)                                   |                   |                 | 47/43 (8.33/6.11) |                 |                   | 37/33 (2.78/0.56) |                   |                 | 27/23 (-2.78/-5)  |                 |                   | 17/13 (-8.33/-10.56) |      |      |
|  |                            |        | Instant. Rating                                       | Integrated Rating | Instant. Rating | Integrated Rating | Instant. Rating | Integrated Rating | Instant. Rating   | Integrated Rating | Instant. Rating | Integrated Rating | Instant. Rating | Integrated Rating |                      |      |      |
| 55 (12.78)                                   | 214                        | Cap kW | 10.99   | 10.99             | 9.55            | 9.55              | 8.13            | 7.40              | 6.80              | 6.04              | 5.55            | 5.06              | 0.83            | 0.77              | 0.71                 | 0.66 | 0.61 |
|  |                            | Cap kW | 11.39   | 11.39             | 9.97            | 9.97              | 8.47            | 7.70              | 7.08              | 6.29              | 5.78            | 5.27              | 0.74            | 0.71              | 0.66                 | 0.62 | 0.58 |
|  |                            | Cap kW | 11.57   | 11.57             | 10.12           | 10.12             | 8.65            | 7.87              | 7.24              | 6.43              | 5.91            | 5.39              | 0.69            | 0.66              | 0.63                 | 0.59 | 0.57 |
| 60 (15.56)                                   | 214                        | Cap kW | 10.75   | 10.75             | 9.31            | 9.31              | 7.93            | 7.21              | 6.60              | 5.86              | 5.36            | 4.88              | 0.87            | 0.80              | 0.74                 | 0.68 | 0.64 |
|  |                            | Cap kW | 11.18   | 11.18             | 9.78            | 9.78              | 8.27            | 7.53              | 6.89              | 6.12              | 5.58            | 5.09              | 0.78            | 0.74              | 0.69                 | 0.64 | 0.61 |
|  |                            | Cap kW | 11.36   | 11.36             | 9.93            | 9.93              | 8.46            | 7.70              | 7.05              | 6.26              | 5.71            | 5.21              | 0.73            | 0.70              | 0.66                 | 0.62 | 0.59 |
| 65 (18.33)                                   | 214                        | Cap kW | 10.51   | 10.51             | 9.11            | 9.11              | 7.72            | 7.02              | 6.39              | 5.67              | 5.15            | 4.69              | 0.90            | 0.84              | 0.77                 | 0.71 | 0.66 |
|  |                            | Cap kW | 10.96   | 10.96             | 9.52            | 9.52              | 8.07            | 7.34              | 6.68              | 5.93              | 5.38            | 4.91              | 0.82            | 0.77              | 0.72                 | 0.67 | 0.64 |
|  |                            | Cap kW | 11.14   | 11.14             | 9.74            | 9.74              | 8.26            | 7.52              | 6.85              | 6.08              | 5.51            | 5.02              | 0.77            | 0.73              | 0.69                 | 0.65 | 0.62 |
| 70 (21.11)                                   | 214                        | Cap kW | 10.28   | 10.28             | 8.88            | 8.88              | 7.50            | 6.83              | 6.18              | 5.48              | 4.93            | 4.50              | 0.94            | 0.87              | 0.80                 | 0.74 | 0.69 |
|  |                            | Cap kW | 10.74   | 10.74             | 9.31            | 9.31              | 7.86            | 7.15              | 6.47              | 5.75              | 5.16            | 4.71              | 0.86            | 0.81              | 0.75                 | 0.70 | 0.66 |
|  |                            | Cap kW | 10.93   | 10.93             | 9.56            | 9.56              | 8.06            | 7.33              | 6.63              | 5.89              | 5.30            | 4.83              | 0.81            | 0.77              | 0.72                 | 0.68 | 0.65 |
| 75 (23.89)                                   | 214                        | Cap kW | 10.04   | 8.66              | 8.64            | 8.64              | 7.28            | 8.66              | 5.96              | 5.29              | 4.71            | 4.29              | 0.97            | 0.90              | 0.83                 | 0.77 | 0.71 |
|  |                            | Cap kW | 10.51   | 8.89              | 9.09            | 9.09              | 7.64            | 8.89              | 6.25              | 5.55              | 4.94            | 4.51              | 0.89            | 0.84              | 0.78                 | 0.73 | 0.69 |
|  |                            | Cap kW | 10.71   | 10.71             | 9.32            | 9.32              | 7.84            | 7.14              | 6.42              | 5.70              | 5.08            | 4.63              | 0.84            | 0.80              | 0.75                 | 0.71 | 0.67 |
| 80 (26.67)                                   | 214                        | Cap kW | 9.80  | 9.80              | 8.40            | 8.40              | 7.06            | 6.42              | 5.74              | 5.09              | 4.47            | 4.08              | 1.01            | 0.93              | 0.86                 | 0.80 | 0.74 |
|  |                            | Cap kW | 10.27   | 10.27             | 8.85            | 8.85              | 7.42            | 6.75              | 6.03              | 5.35              | 4.71            | 4.30              | 0.93            | 0.87              | 0.81                 | 0.76 | 0.72 |
|  |                            | Cap kW | 10.49   | 10.49             | 9.11            | 9.11              | 7.62            | 6.94              | 6.19              | 5.50              | 4.84            | 0.97              | 0.88            | 0.84              | 0.78                 | 0.74 | 0.70 |

Indicates Rating Condition (\* Integrated Capacity)

Indicates Integrated Rating

Cap – Heating Capacity (100 Btuh), Includes indoor fan motor heat

kW – Total Power Input, includes compressor motor power input, outdoor fan motor power input, and indoor fan motor power input  
**Note:** Integrated Capacity is maximum (instantaneous) capacity less the effect of frost on the outdoor coil and the heat to defrost it.

**PERFORMANCE DATA (CONT.)**

**INSTANTANEOUS AND INTEGRATED HEATING RATINGS**  
38MVQ012-1 / 40MVQ012-1

| Air Temperature Entering Indoor Unit °F (°C) | Indoor Airflow (CFM) L-M-H | Item   | Air Temperature Entering Outdoor Coil – DB/WB °F (°C) |                   |                   |                   |                   |                   |                  |                   |                      |                   |
|--|----------------------------|--------|---|-------------------|-------------------|-------------------|-------------------|-------------------|------------------|-------------------|----------------------|-------------------|
|  |                            |        | 57/53 (13.89/11.67)                                   |                   | 47/43 (8.33/6.11) |                   | 37/33 (2.78/0.56) |                   | 27/23 (-2.78/-5) |                   | 17/13 (-8.33/-10.56) |                   |
|  |                            |        | Instant. Rating                                       | Integrated Rating | Instant. Rating   | Integrated Rating | Instant. Rating   | Integrated Rating | Instant. Rating  | Integrated Rating | Instant. Rating      | Integrated Rating |
| 55 (12.78)                                   | 304                        | Cap kW | 14.78   | 14.78             | 12.92             | 12.92             | 11.39             | 10.36             | 9.62             | 8.55              | 7.80                 | 7.11              |
|  |                            | Cap kW | 14.85   | 14.85             | 12.97             | 12.97             | 11.44             | 10.41             | 9.74             | 8.65              | 7.90                 | 7.20              |
|  |                            | Cap kW | 14.85   | 14.85             | 13.03             | 13.03             | 11.45             | 10.42             | 9.89             | 8.79              | 8.05                 | 7.34              |
| 60 (15.56)                                   | 304                        | Cap kW | 14.63   | 14.63             | 12.81             | 12.81             | 11.21             | 10.20             | 9.32             | 8.28              | 7.60                 | 6.93              |
|  |                            | Cap kW | 14.71   | 14.71             | 12.85             | 12.85             | 11.35             | 10.32             | 9.55             | 8.48              | 7.70                 | 7.02              |
|  |                            | Cap kW | 14.75   | 14.75             | 12.91             | 12.91             | 11.36             | 10.34             | 9.71             | 8.62              | 7.83                 | 7.14              |
| 65 (18.33)                                   | 304                        | Cap kW | 14.46   | 14.46             | 12.67             | 12.67             | 11.02             | 10.03             | 9.07             | 8.05              | 7.35                 | 6.70              |
|  |                            | Cap kW | 14.56   | 14.56             | 12.73             | 12.73             | 11.17             | 10.16             | 9.22             | 8.18              | 7.47                 | 6.81              |
|  |                            | Cap kW | 14.63   | 14.63             | 12.78             | 12.78             | 11.26             | 10.24             | 9.45             | 8.39              | 7.63                 | 6.95              |
| 70 (21.11)                                   | 304                        | Cap kW | 14.29   | 14.29             | 12.52             | 12.52             | 10.82             | 9.84              | 8.82             | 7.83              | 7.10                 | 6.47              |
|  |                            | Cap kW | 14.40   | 14.40             | 12.60             | 12.60             | 10.97             | 9.98              | 8.96             | 7.96              | 7.21                 | 6.57              |
|  |                            | Cap kW | 14.49   | 14.49             | 12.67             | 12.67             | 11.16             | 10.16             | 9.16             | 8.14              | 7.38                 | 6.73              |
| 75 (23.89)                                   | 304                        | Cap kW | 14.11   | 8.66              | 12.37             | 12.37             | 10.52             | 8.66              | 8.60             | 7.63              | 6.88                 | 6.27              |
|  |                            | Cap kW | 14.24   | 8.89              | 12.46             | 12.46             | 10.75             | 8.89              | 8.72             | 7.74              | 6.98                 | 6.37              |
|  |                            | Cap kW | 14.34   | 14.34             | 12.55             | 12.55             | 10.96             | 9.98              | 8.90             | 7.90              | 7.12                 | 6.49              |
| 80 (26.67)                                   | 304                        | Cap kW | 13.93   | 13.93             | 12.22             | 12.22             | 10.24             | 9.31              | 8.36             | 7.42              | 6.65                 | 6.07              |
|  |                            | Cap kW | 14.06   | 14.06             | 12.31             | 12.31             | 10.42             | 9.48              | 8.49             | 7.54              | 6.75                 | 6.16              |
|  |                            | Cap kW | 14.18   | 14.18             | 12.41             | 12.41             | 10.74             | 9.77              | 8.66             | 7.69              | 6.89                 | 6.38              |

Indicates Rating Condition (\* Integrated Capacity)

Indicates Integrated Rating

Cap – Heating Capacity (100 Btuh), Includes indoor fan motor heat

kw – Total Power Input, includes compressor motor power input, outdoor fan motor power input, and indoor fan motor power input

**Note:** Integrated Capacity is maximum (instantaneous) capacity less the effect of frost on the outdoor coil and the heat to defrost it.

# PERFORMANCE DATA (CONT.)

## INSTANTANEOUS AND INTEGRATED HEATING RATINGS 38MVQ012-3 / 40MVQ012-3

| Air Temperature Entering Indoor Unit °F (°C) | Indoor Airflow (CFM) L-M-H | Item   | Air Temperature Entering Outdoor Coil – DB/WB °F (°C) |                   |      |                   |                   |      |                   |                   |      |                  |                   |      |                      |                   |      |
|--|----------------------------|--------|---|-------------------|------|-------------------|-------------------|------|-------------------|-------------------|------|------------------|-------------------|------|----------------------|-------------------|------|
|  |                            |        | 57/53 (13.89/11.67)                                   |                   |      | 47/43 (8.33/6.11) |                   |      | 37/33 (2.78/0.56) |                   |      | 27/23 (-2.78/-5) |                   |      | 17/13 (-8.33/-10.56) |                   |      |
|  |                            |        | Instant. Rating                                       | Integrated Rating | Cap  | Instant. Rating   | Integrated Rating | Cap  | Instant. Rating   | Integrated Rating | Cap  | Instant. Rating  | Integrated Rating | Cap  | Instant. Rating      | Integrated Rating | Cap  |
| 55 (12.78)                                   | 304                        | Cap kW | 15.21   | 15.21             | 1.08 | 13.32             | 13.32             | 0.99 | 11.58             | 10.54             | 0.91 | 9.83             | 8.73              | 0.84 | 8.06                 | 7.35              | 0.77 |
|  | 343                        | Cap kW | 15.31   | 15.31             | 1.02 | 13.40             | 13.40             | 0.94 | 11.75             | 10.69             | 0.88 | 9.94             | 8.83              | 0.81 | 8.20                 | 7.48              | 0.76 |
|  | 414                        | Cap kW | 15.37   | 15.37             | 0.95 | 13.47             | 13.47             | 0.89 | 11.84             | 10.78             | 0.83 | 10.10            | 8.97              | 0.78 | 8.44                 | 7.69              | 0.73 |
| 60 (15.56)                                   | 304                        | Cap kW | 15.01   | 15.01             | 1.13 | 13.16             | 13.16             | 1.04 | 11.37             | 10.35             | 0.95 | 9.64             | 8.56              | 0.88 | 7.81                 | 7.12              | 0.81 |
|  | 343                        | Cap kW | 15.13   | 15.13             | 1.08 | 13.25             | 13.25             | 0.99 | 11.54             | 10.50             | 0.92 | 9.76             | 8.67              | 0.85 | 7.94                 | 7.24              | 0.79 |
|  | 414                        | Cap kW | 15.23   | 15.23             | 1.01 | 13.33             | 13.33             | 0.93 | 11.71             | 10.65             | 0.88 | 9.92             | 8.81              | 0.82 | 8.12                 | 7.40              | 0.77 |
| 65 (18.33)                                   | 304                        | Cap kW | 14.80   | 14.80             | 1.18 | 12.96             | 12.96             | 1.09 | 11.18             | 10.17             | 0.93 | 9.43             | 8.37              | 0.92 | 7.55                 | 6.89              | 0.84 |
|  | 343                        | Cap kW | 14.94   | 14.94             | 1.13 | 13.08             | 13.08             | 1.04 | 11.33             | 10.31             | 0.97 | 9.56             | 8.49              | 0.89 | 7.69                 | 7.01              | 0.82 |
|  | 414                        | Cap kW | 15.06   | 15.06             | 1.06 | 13.16             | 13.16             | 0.98 | 11.55             | 10.51             | 0.93 | 9.74             | 8.65              | 0.86 | 7.86                 | 7.17              | 0.80 |
| 70 (21.11)                                   | 304                        | Cap kW | 14.58   | 14.58             | 1.24 | 12.77             | 12.77             | 1.14 | 10.97             | 9.99              | 1.04 | 9.10             | 8.08              | 0.95 | 7.28                 | 6.64              | 0.87 |
|  | 343                        | Cap kW | 14.74   | 14.74             | 1.19 | 12.89             | 12.89             | 1.09 | 11.12             | 10.12             | 1.01 | 9.28             | 8.24              | 0.93 | 7.42                 | 6.76              | 0.86 |
|  | 414                        | Cap kW | 14.90   | 14.90             | 1.11 | 13.01             | 13.01             | 1.03 | 11.33             | 10.31             | 0.97 | 9.53             | 8.46              | 0.90 | 7.61                 | 6.94              | 0.83 |
| 75 (23.89)                                   | 304                        | Cap kW | 14.35   | 8.66              | 1.30 | 12.57             | 12.57             | 1.19 | 10.76             | 8.66              | 1.09 | 8.83             | 7.84              | 0.98 | 7.04                 | 6.42              | 0.91 |
|  | 343                        | Cap kW | 14.51   | 8.89              | 1.24 | 12.70             | 12.70             | 1.15 | 10.92             | 8.89              | 1.06 | 8.98             | 7.97              | 0.96 | 7.15                 | 6.52              | 0.89 |
|  | 414                        | Cap kW | 14.69   | 14.69             | 1.17 | 12.84             | 12.84             | 1.09 | 11.12             | 10.12             | 1.02 | 9.21             | 8.18              | 0.93 | 7.32                 | 6.68              | 0.87 |
| 80 (26.67)                                   | 304                        | Cap kW | 14.12   | 14.12             | 1.35 | 12.32             | 12.32             | 1.24 | 10.52             | 9.57              | 1.13 | 8.56             | 7.60              | 1.02 | 6.80                 | 6.20              | 0.95 |
|  | 343                        | Cap kW | 14.29   | 14.29             | 1.30 | 12.51             | 12.51             | 1.20 | 10.69             | 9.73              | 1.10 | 8.70             | 7.72              | 1.00 | 6.92                 | 6.31              | 0.93 |
|  | 414                        | Cap kW | 14.48   | 14.48             | 1.22 | 12.65             | 12.65             | 1.14 | 10.91             | 9.93              | 1.06 | 8.92             | 7.92              | 0.97 | 7.06                 | 1.41              | 0.91 |

Indicates Rating Condition (\* Integrated Capacity)

Indicates Integrated Rating

Cap – Heating Capacity (100 Btuh), Includes indoor fan motor heat

kw – Total Power Input, includes compressor motor power input, outdoor fan motor power input, and indoor fan motor power input  
 Note: Integrated Capacity is maximum (instantaneous) capacity less the effect of frost on the outdoor coil and the heat to defrost it.

**PERFORMANCE DATA (CONT.)**

**INSTANTANEOUS AND INTEGRATED HEATING RATINGS**  
38MVQ018-3 / 40MVQ018-3

| Air Temperature Entering Indoor Unit °F (°C) | Indoor Airflow (CFM) L-M-H | Item | Air Temperature Entering Outdoor Coil – DB/WB °F (°C) |                   |      |                   |                   |      |                   |                   |      |                  |                   |      |                      |                   |      |
|--|----------------------------|------|---|-------------------|------|-------------------|-------------------|------|-------------------|-------------------|------|------------------|-------------------|------|----------------------|-------------------|------|
|  |                            |      | 57/53 (13.89/11.67)                                   |                   |      | 47/43 (8.33/6.11) |                   |      | 37/33 (2.78/0.56) |                   |      | 27/23 (-2.78/-5) |                   |      | 17/13 (-8.33/-10.56) |                   |      |
|  |                            |      | Instant. Rating                                       | Integrated Rating | Cap  | Instant. Rating   | Integrated Rating | Cap  | Instant. Rating   | Integrated Rating | Cap  | Instant. Rating  | Integrated Rating | Cap  | Instant. Rating      | Integrated Rating | Cap  |
| 55 (12.78)                                   | 426                        | Cap  | 18.57   | 18.57             | 1.48 | 16.44             | 16.44             | 1.38 | 14.04             | 14.04             | 0.00 | 11.47            | 11.47             | 1.17 | 9.32                 | 9.32              | 1.20 |
|  | 449                        | Cap  | 18.69   | 18.69             | 1.46 | 16.53             | 16.53             | 1.36 | 14.04             | 14.04             | 0.00 | 11.57            | 11.57             | 1.16 | 9.39                 | 9.39              | 1.19 |
|  | 539                        | Cap  | 18.99   | 18.99             | 1.37 | 16.76             | 16.76             | 1.29 | 14.59             | 14.59             | 1.25 | 11.90            | 11.90             | 1.12 | 9.62                 | 9.62              | 1.16 |
| 60 (15.56)                                   | 426                        | Cap  | 18.23   | 18.23             | 1.55 | 16.12             | 16.12             | 1.44 | 13.48             | 13.48             | 1.31 | 11.10            | 11.10             | 1.22 | 8.97                 | 8.97              | 1.24 |
|  | 449                        | Cap  | 18.34   | 18.34             | 1.52 | 16.23             | 16.23             | 1.42 | 13.61             | 13.61             | 1.30 | 11.19            | 11.19             | 1.21 | 9.04                 | 9.04              | 1.23 |
|  | 539                        | Cap  | 18.66   | 18.66             | 1.44 | 16.49             | 16.49             | 1.35 | 14.03             | 14.03             | 1.26 | 11.49            | 11.49             | 1.17 | 9.26                 | 9.26              | 1.20 |
| 65 (18.33)                                   | 426                        | Cap  | 17.87   | 17.87             | 1.62 | 15.60             | 15.60             | 1.49 | 13.05             | 13.05             | 1.36 | 10.71            | 10.71             | 1.26 | 8.61                 | 8.61              | 1.29 |
|  | 449                        | Cap  | 18.00   | 18.00             | 1.59 | 15.88             | 15.88             | 1.48 | 13.18             | 13.18             | 1.35 | 10.81            | 10.81             | 1.25 | 8.68                 | 8.68              | 1.28 |
|  | 539                        | Cap  | 18.32   | 18.32             | 1.50 | 16.19             | 16.19             | 1.41 | 13.59             | 13.59             | 1.30 | 11.10            | 11.10             | 1.22 | 8.90                 | 8.90              | 1.25 |
| 70 (21.11)                                   | 426                        | Cap  | 17.53   | 17.53             | 1.68 | 15.09             | 15.09             | 1.54 | 12.60             | 12.60             | 1.41 | 10.32            | 10.32             | 1.31 | 8.26                 | 8.26              | 1.33 |
|  | 449                        | Cap  | 17.65   | 17.65             | 1.66 | 15.26             | 15.26             | 1.52 | 12.73             | 12.73             | 1.40 | 10.41            | 10.41             | 1.30 | 8.32                 | 8.32              | 1.32 |
|  | 539                        | Cap  | 17.98   | 17.98             | 1.57 | 15.88             | 15.88             | 1.47 | 13.16             | 13.16             | 1.35 | 10.71            | 10.71             | 1.27 | 8.52                 | 8.52              | 1.30 |
| 75 (23.89)                                   | 426                        | Cap  | 17.17   | 8.66              | 1.75 | 14.66             | 14.66             | 1.59 | 12.15             | 12.15             | 1.46 | 9.92             | 9.92              | 1.36 | 7.86                 | 7.86              | 1.50 |
|  | 449                        | Cap  | 17.29   | 8.89              | 1.72 | 14.79             | 14.79             | 1.57 | 12.27             | 12.27             | 1.45 | 10.01            | 10.01             | 1.35 | 7.93                 | 7.93              | 1.50 |
|  | 539                        | Cap  | 17.64   | 17.64             | 1.64 | 15.30             | 15.30             | 1.52 | 12.69             | 12.69             | 1.40 | 10.30            | 10.30             | 1.31 | 8.16                 | 8.16              | 1.37 |
| 80 (26.67)                                   | 426                        | Cap  | 16.75   | 16.75             | 1.81 | 14.19             | 14.19             | 1.65 | 11.72             | 11.72             | 1.51 | 9.51             | 9.51              | 1.41 | 7.46                 | 7.46              | 1.43 |
|  | 449                        | Cap  | 16.92   | 16.92             | 1.79 | 14.35             | 14.35             | 1.63 | 11.84             | 11.84             | 1.50 | 9.60             | 9.60              | 1.40 | 7.53                 | 7.53              | 1.42 |
|  | 539                        | Cap  | 17.28   | 17.28             | 1.71 | 14.82             | 14.82             | 1.57 | 12.22             | 12.22             | 1.46 | 9.88             | 9.88              | 1.36 | 7.73                 | 7.73              | 1.40 |

Indicates Rating Condition (\* Integrated Capacity)

Indicates Integrated Rating

Cap – Heating Capacity (100 Btuh), Includes indoor fan motor heat

kW – Total Power Input, includes compressor motor power input, outdoor fan motor power input, and indoor fan motor power input

**Note:** Integrated Capacity is maximum (instantaneous) capacity less the effect of frost on the outdoor coil and the heat to defrost it.

# PERFORMANCE DATA (CONT.)

## INSTANTANEOUS AND INTEGRATED HEATING RATINGS 38MVQ024-3 / 40MVQ024-3

| Air Temperature Entering Indoor Unit °F (°C) | Indoor Airflow (CFM) L-M-H | Item   | Air Temperature Entering Outdoor Coil – DB/WB °F (°C) |                   |                   |                   |                   |                   |                  |                   |                      |                   |  |  |
|--|----------------------------|--------|---|-------------------|-------------------|-------------------|-------------------|-------------------|------------------|-------------------|----------------------|-------------------|--|--|
|  |                            |        | 57/53 (13.89/11.67)                                   |                   | 47/43 (8.33/6.11) |                   | 37/33 (2.78/0.56) |                   | 27/23 (-2.78/-5) |                   | 17/13 (-8.33/-10.56) |                   |  |  |
|  |                            |        | Instant. Rating                                       | Integrated Rating | Instant. Rating   | Integrated Rating | Instant. Rating   | Integrated Rating | Instant. Rating  | Integrated Rating | Instant. Rating      | Integrated Rating |  |  |
| 55 (12.78)                                   | 625                        | Cap kW | 25.79   | 25.79             | 22.58             | 22.58             | 19.52             | 17.77             | 16.24            | 14.42             | 13.28                | 12.11             |  |  |
|  |                            | Cap kW | 1.76  | 1.76              | 1.63              | 1.63              | 1.52              | 1.41              | 1.41             | 1.32              | 1.32                 | 1.32              |  |  |
|  |                            | Cap kW | 25.99   | 25.99             | 22.72             | 22.72             | 19.81             | 18.03             | 16.40            | 14.57             | 13.43                | 12.25             |  |  |
| 60 (15.56)                                   | 774                        | Cap kW | 26.14   | 26.14             | 22.85             | 22.85             | 20.12             | 18.31             | 16.65            | 14.78             | 13.59                | 12.39             |  |  |
|  |                            | Cap kW | 1.63  | 1.63              | 1.53              | 1.53              | 1.45              | 1.36              | 1.36             | 1.29              | 1.29                 | 1.29              |  |  |
|  |                            | Cap kW | 25.42   | 25.42             | 22.28             | 22.28             | 18.96             | 17.26             | 15.78            | 14.02             | 12.90                | 11.76             |  |  |
| 65 (18.33)                                   | 774                        | Cap kW | 25.61   | 25.61             | 22.42             | 22.42             | 19.26             | 17.53             | 15.98            | 14.19             | 13.00                | 11.85             |  |  |
|  |                            | Cap kW | 1.78  | 1.78              | 1.66              | 1.66              | 1.55              | 1.45              | 1.45             | 1.36              | 1.36                 | 1.36              |  |  |
|  |                            | Cap kW | 25.80   | 25.80             | 22.55             | 22.55             | 19.56             | 17.80             | 16.20            | 14.38             | 13.16                | 12.00             |  |  |
| 70 (21.11)                                   | 689                        | Cap kW | 25.02   | 25.02             | 21.92             | 21.92             | 18.39             | 16.74             | 15.36            | 13.64             | 12.39                | 11.29             |  |  |
|  |                            | Cap kW | 1.92  | 1.92              | 1.78              | 1.78              | 1.64              | 1.53              | 1.53             | 1.43              | 1.43                 | 1.43              |  |  |
|  |                            | Cap kW | 25.23   | 25.23             | 22.08             | 22.08             | 18.73             | 17.05             | 15.49            | 13.75             | 12.54                | 11.44             |  |  |
| 75 (23.89)                                   | 689                        | Cap kW | 25.44   | 25.44             | 22.26             | 22.26             | 19.03             | 17.32             | 15.71            | 13.95             | 12.70                | 11.58             |  |  |
|  |                            | Cap kW | 1.80  | 1.80              | 1.68              | 1.68              | 1.58              | 1.48              | 1.48             | 1.39              | 1.39                 | 1.39              |  |  |
|  |                            | Cap kW | 24.62   | 24.62             | 21.46             | 21.46             | 18.00             | 16.38             | 14.87            | 13.21             | 11.92                | 10.87             |  |  |
| 80 (26.67)                                   | 774                        | Cap kW | 24.82   | 24.82             | 21.68             | 21.68             | 18.24             | 16.60             | 15.01            | 13.33             | 12.07                | 11.00             |  |  |
|  |                            | Cap kW | 1.95  | 1.95              | 1.81              | 1.81              | 1.68              | 1.57              | 1.57             | 1.47              | 1.47                 | 1.47              |  |  |
|  |                            | Cap kW | 25.04   | 25.04             | 21.90             | 21.90             | 18.50             | 16.83             | 15.23            | 13.52             | 12.26                | 11.18             |  |  |
| 625  | 689                        | Cap kW | 24.18   | 24.18             | 20.85             | 20.85             | 17.46             | 15.86             | 14.38            | 12.77             | 11.43                | 10.43             |  |  |
|  |                            | Cap kW | 2.09  | 2.09              | 1.92              | 1.92              | 1.78              | 1.65              | 1.65             | 1.55              | 1.55                 | 1.55              |  |  |
|  |                            | Cap kW | 24.41   | 24.41             | 21.23             | 21.23             | 17.65             | 16.03             | 14.52            | 12.89             | 11.59                | 10.56             |  |  |
| 774  | 689                        | Cap kW | 24.64   | 24.64             | 21.49             | 21.49             | 17.96             | 16.34             | 14.74            | 13.09             | 11.75                | 10.71             |  |  |
|  |                            | Cap kW | 1.98  | 1.98              | 1.84              | 1.84              | 1.71              | 1.60              | 1.60             | 1.51              | 1.51                 | 1.51              |  |  |
|  |                            | Cap kW | 23.70   | 23.70             | 20.22             | 20.22             | 16.93             | 15.41             | 13.82            | 12.28             | 10.94                | 9.97              |  |  |
| 689  | 774                        | Cap kW | 23.94   | 23.94             | 20.59             | 20.59             | 17.17             | 15.62             | 14.01            | 12.44             | 11.08                | 10.11             |  |  |
|  |                            | Cap kW | 2.11  | 2.11              | 1.95              | 1.95              | 1.81              | 1.69              | 1.69             | 1.59              | 1.59                 | 1.59              |  |  |
|  |                            | Cap kW | 24.22   | 24.22             | 20.98             | 20.98             | 17.44             | 15.87             | 14.22            | 12.63             | 11.25                | 2.25              |  |  |
| 774  | 689                        | Cap kW | 24.22   | 24.22             | 20.98             | 20.98             | 17.44             | 15.87             | 14.22            | 12.63             | 11.25                | 2.25              |  |  |
|  |                            | Cap kW | 2.06  | 2.06              | 1.91              | 1.91              | 1.78              | 1.67              | 1.67             | 1.57              | 1.57                 | 1.57              |  |  |
|  |                            | Cap kW | 24.22   | 24.22             | 20.98             | 20.98             | 17.44             | 15.87             | 14.22            | 12.63             | 11.25                | 2.25              |  |  |

Indicates Rating Condition (Integrated Capacity)

Indicates Integrated Rating

Cap – Heating Capacity (100 Btu/h), Includes indoor fan motor heat

kW – Total Power Input, includes compressor motor power input, outdoor fan motor power input, and indoor fan motor power input  
**Note:** Integrated Capacity is maximum (instantaneous) capacity less the effect of frost on the outdoor coil and the heat to defrost it.

# APPLICATION DATA

## UNIT SELECTION

Select equipment to either match or be slightly less than anticipated peak load. This provides better humidity control, fewer unit cycles, and less part-load operation.

For units used in spaces with high sensible loads, base equipment selection on unit sensible load, not on total anticipated load. Adjust for anticipated room wet bulb temperature to avoid undersizing equipment.

## UNIT MOUNTING (INDOOR)

**Unit leveling** - For reliable operation, units should be level in all planes.

**Clearance** - Provide adequate clearance for airflow as shown in Fig. 2.

**Unit location** - Select a location which will provide the best air circulation for the room.

These units should be positioned as high as possible on the wall for best air circulation. The unit return and discharge should not be obstructed by furniture, curtains, or anything which may cause unit short cycling or air recirculation. Place the unit in the middle of the selected wall (if possible). Use an outside wall, if available, to make piping easier, and place the unit so it faces the normal location of room occupants.

## UNIT MOUNTING (OUTDOOR)

**Unit leveling** - For reliable operation, units should be level in all planes.

**Clearance** - Minimum clearance, as shown in Fig. 3, must be provided for airflow. The condensing units are designed for free-blow application. Air inlets and outlets should not be restricted.

**Unit location** - A location which is convenient to installation and not exposed to strong wind. If unit is exposed to strong winds it is recommended that a wind baffle be used. Contact your Carrier representative for drawings.

A location which can bear the weight of outdoor unit and where the outdoor unit can be mounted in a level position.

Do not install the indoor or outdoor units in a location with special environmental conditions. For those applications, contact your Carrier representative.

## MOUNTING TEMPLATE

The fan coil units are furnished with mounting to mark the location of the wiring, and refrigeration line hole locations.

## SUPPORT

Adequate support must be provided to support the weight of all fan coils. Refer to the Physical Data section for fan coil weights, and the base unit dimensional drawings for the location of mounting brackets.

# SYSTEM OPERATING CONDITIONS

## Cooling operating range:

|              | Maximum     |            | Minimum    |            |
|--------------|-------------|------------|------------|------------|
|              | DB °F (°C)  | WB °F (°C) | DB °F (°C) | WB °F (°C) |
| Outdoor Unit | 125 (51.67) | -          | 55 (12.78) | -          |
| Indoor Unit  | 85 (29.44)  | 72 (22.22) | 64 (17.78) | 52 (11.11) |

## Heating operating range:

|              | Maximum    |            | Minimum    |            |
|--------------|------------|------------|------------|------------|
|              | DB °F (°C) | WB °F (°C) | DB °F (°C) | WB °F (°C) |
| Outdoor Unit | 75 (23.89) | 67 (19.44) | 5 (-15)    | 50% RH     |
| Indoor Unit  | 80 (26.67) | -          | 55 (12.78) | -          |

## LOW AMBIENT OPERATION

Units can operate in cooling down to 55°F (12.78°C) under all conditions without a low-ambient kit.

Units equipped with accessory low-ambient kits should also be equipped with field fabricated (drawings available) wind baffle and crankcase heater to prevent refrigerant migration during compressor off cycle.

## METERING DEVICES

These units have capillary tube metering devices in the outdoor unit.

## DRAIN CONNECTIONS

Install drains to meet local sanitation codes. If adequate gravity drainage cannot be provided, unit should be equipped with accessory condensate pump. High wall fan coil unit condensate pumps have a maximum lift of 10' (3.05 m) for 9k and 12k units and 25' (7.62 m) for 18k and 24k units.

See physical dimension tables for drain sizes.

**NOTE: High wall fan coil units have internal condensate traps. A trap is not required.**

Drain connections may be routed through alternate locations on most fan coils as shown in Fig. 4.

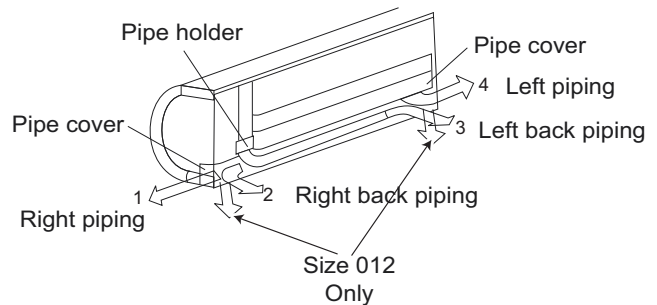

Fig. 4 – Piping Locations

A07344

## REFRIGERANT LINES

### General refrigerant line sizing:

1. The 38MVC/MVQ units are shipped with a full charge of R410A refrigerant. All charges, line sizing, and capacities are based on runs of 25 ft (7.6 m). For runs over 25 ft (7.6 m), consult long-line section on this page for proper charge adjustments.
2. Refrigerant lines should not be buried in the ground. If it is necessary to bury the lines, not more than 36-in (914 mm) should be buried. Provide a minimum 6-in (152 mm) vertical rise to the service valves to prevent refrigerant migration.
3. Both lines must be insulated. Use a minimum of 1/2-in. (12.7 mm) thick insulation. Closed-cell insulation is recommended in all long-line applications.
4. Special consideration should be given to isolating interconnecting tubing from the building structure. Isolate the tubing so that vibration or noise is not transmitted into the structure.

### Long Line Applications, 38MVC Units:

1. A crankcase heater should be added for line lengths longer than 25 ft (7.62 m) to prevent the migration of refrigerant to the compressor during the “OFF” cycle.
2. A field fabricated wind baffle is recommended.
3. No change in line sizing is required.
4. Add refrigerant per table below.

ADDITIONAL CHARGE TABLE

| Unit Size     | Total Line Length, ft |      | Additional Charge, oz. ft (m) |                          |                            |
|---------------|-----------------------|------|-------------------------------|--------------------------|----------------------------|
|               | Min.                  | Max. | 10 – 25<br>(3.05 – 7.62)      | >25 – 65<br>(7.62–19.81) | >65 – 100<br>(19.81–30.48) |
| 9K cool only  | 10                    | 65   | none                          | 0.1 oz per foot          |                            |
| 9K hp         |                       |      |                               |                          |                            |
| 12K cool only |                       |      |                               |                          |                            |
| 12K hp        | 100                   |      |                               |                          | 0.3 oz. per foot           |
| 18K cool only |                       |      |                               |                          |                            |
| 18K hp        |                       |      |                               |                          |                            |
| 24K cool only |                       |      |                               |                          |                            |
| 24K hp        |                       |      |                               |                          |                            |

5. Reduction in capacity due to long lines can be calculated from the chart below.

### CAPACITY LOSS

| Capacity, % Loss      | Line Length, ft |    |     |     |
|-----------------------|-----------------|----|-----|-----|
|                       | 25              | 45 | 65  | 100 |
| <b>Cooling:</b>       |                 |    |     |     |
| 9 & 12 KBTU/H models  | 0%              | 2% | 5%  |     |
| 18 & 24 KBTU/H models | 0%              | 2% | 4%  | 7%  |
| <b>Heating:</b>       |                 |    |     |     |
| 9 & 12 KBTU/H models  | 0%              | 7% | 11% |     |
| 18 & 24 KBTU/H models | 0%              | 7% | 11% | 15% |

## WIRING

The main power is supplied to the outdoor unit. The field supplied connecting cable from the outdoor unit to indoor unit consists of four wires and provides the power for the indoor unit as well as the communication signal between the outdoor unit and indoor unit. For 9K and 12K units, all four wires are low voltage DC.

For 18K and 24K, two wires are high voltage AC power, one is low voltage DC, and one is a ground wire.

## CONTROL SYSTEM

The 40MVC/MVQ unit is equipped with a microprocessor controls to operate the system and give optimum levels of comfort and operating efficiency.

The main microprocessor is located in the control box of the fan coil unit (there is one in the outdoor unit too) with thermistors located in the fan coil inlet and on the indoor coil. These thermistors monitor the system operation and control the operating mode. To change the settings or the modes of operation, use the factory supplied wireless remote control.

The 40MVC/MVQ unit has 5 operating modes:

- Fan Only
- Auto (heat pump models only)
- Heating (heat pump models only)
- Cooling
- Dehumidification (Dry)

**FAN ONLY** - In Fan Only mode, the system filters and circulates the room air without changing the room air temperature.

**AUTO** - In Auto mode, the system will automatically select one of the following operating modes: cooling, heating or fan only based on the difference between the room temperature and the set point temperature.

**HEATING** - In the Heating mode, the system heats and filters room air.

**COOLING** - In Cooling mode, the system cools, dries and filters room air.

**DEHUMIDIFICATION (DRY)** - in Dehumidification (Dry) mode, the system dries, filters and slightly cools room temperature. This mode does not take place of a dehumidifier.

In addition to the above modes that are selected by using the remote control, The unit can run in two other modes selected by the manual button:

- EMERGENCY RUN
- TEST MODE

**EMERGENCY** mode is used when the remote control is misplaced or the batteries in the remote control died. Pushing the manual button once will put the unit in Auto mode with a predetermined set point (76 °F/ 24.4 °C).

**TEST** mode is used when a technician needs to diagnose the unit for a malfunction. Pushing the manual button twice will put the unit in test mode. The unit will run continuously for 30 min regardless of the set point.

For more details on the sequence of operation please refer to the service manual for those units.

## WIRELESS REMOTE CONTROL

1. A wireless remote control is supplied for system operation of all high-wall units.
2. Each battery-operated wireless (infrared) remote control may be used to control more than one unit.
3. The wireless remote control has a range of 25 ft. (7.6 m).

# AIR THROW DATA

| UNIT CAPACITY | APPROXIMATE AIR THROW ft. (m) |          |           |
|---------------|-------------------------------|----------|-----------|
|               | Low                           | Medium   | High      |
| 009 115v      | 14 (4.3 m)                    | 18 (5.5) | 28 (8.5)  |
| 012 115v      | 16 (4.9)                      | 20 (6.1) | 30 (9.1)  |
| 012 208/230v  | 16 (4.9)                      | 20 (6.1) | 30 (9.1)  |
| 018 208/230v  | 22 (6.7)                      | 37 (8.2) | 35 (10.7) |
| 024 208/230v  | 23 (7.0)                      | 31 (9.4) | 40 (12.2) |

# SOUND RATINGS

## Outdoor Units

| Model Number | Sound Power dBa | Sound Pressure dBa |
|--------------|-----------------|--------------------|
| 38MVC009---1 | 65              | 54                 |
| 38MVC012---1 | 65              | 54                 |
| 38MVC012---3 | 65              | 54                 |
| 38MVC018---3 | 68              | 57                 |
| 38MVC024---3 | 67              | 56                 |
| 38MVQ009---1 | 64/66 (Clg/Htg) | 53/55 (Clg/Htg)    |
| 38MVQ012---1 | 63/64 (Clg/Htg) | 52/53 (Clg/Htg)    |
| 38MVQ012---3 | 63/64 (Clg/Htg) | 52/53 (Clg/Htg)    |
| 38MVQ018---3 | 68/72 (Clg/Htg) | 57/61 (Clg/Htg)    |
| 38MVQ024---3 | 65/67 (Clg/Htg) | 54/56 (Clg/Htg)    |

## Indoor Units

| Model Number | High            |                    | Medium          |                    | Low             |                    |
|--------------|-----------------|--------------------|-----------------|--------------------|-----------------|--------------------|
|              | Sound Power dBa | Sound Pressure dBa | Sound Power dBa | Sound Pressure dBa | Sound Power dBa | Sound Pressure dBa |
| 40MVC009---1 | 53              | 42                 | 47              | 36                 | 39              | 28                 |
| 40MVC012---1 | 58              | 47                 | 53              | 42                 | 51              | 40                 |
| 40MVC012---3 | 58              | 47                 | 53              | 42                 | 51              | 40                 |
| 40MVC018---3 | 59              | 48                 | 56              | 45                 | 54              | 43                 |
| 40MVC024---3 | 64              | 53                 | 61              | 50                 | 59              | 48                 |
| 40MVQ009---1 | 52/54 (Clg/Htg) | 41/43 (Clg/Htg)    | 47/47 (Clg/Htg) | 36/36 (Clg/Htg)    | 42/44 (Clg/Htg) | 31/33 (Clg/Htg)    |
| 40MVQ012---1 | 59/58 (Clg/Htg) | 48/47 (Clg/Htg)    | 54/51 (Clg/Htg) | 43/40 (Clg/Htg)    | 51/47 (Clg/Htg) | 40/36 (Clg/Htg)    |
| 40MVQ012---3 | 59/58 (Clg/Htg) | 48/47 (Clg/Htg)    | 54/51 (Clg/Htg) | 43/40 (Clg/Htg)    | 51/47 (Clg/Htg) | 40/36 (Clg/Htg)    |
| 40MVQ018---3 | 58/57 (Clg/Htg) | 47/46 (Clg/Htg)    | 56/56 (Clg/Htg) | 45/45 (Clg/Htg)    | 54/54 (Clg/Htg) | 43/43 (Clg/Htg)    |
| 40MVQ024---3 | 65/66 (Clg/Htg) | 54/55 (Clg/Htg)    | 62/64 (Clg/Htg) | 51/53 (Clg/Htg)    | 59/60 (Clg/Htg) | 48/49 (Clg/Htg)    |

### NOTES:

1. Sound power ratings are per ARI 270 and ARI 350
2. Sound pressure ratings are estimated sound pressure, 3 feet (.91 m) from the unit, based on sound power data.

# ELECTRICAL DATA

| UNIT SIZE | OPERATING VOLTAGE* | COMPRESSOR   |     |      | OUTDOOR FAN |       |     | INDOOR FAN   |      |       |    | MCA | MAX FUSE/CB AMP |
|-----------|--------------------|--------------|-----|------|-------------|-------|-----|--------------|------|-------|----|-----|-----------------|
|           |                    | VOLTS-PH-HZ  | RLA | LRA  | FLA         | HP    | W   | VOLTS        | FLA  | HP    | W  |     |                 |
| 009       | 127/104            | 115-1-60     | 7.5 | 40   | 0.60        | 0.102 | 23  | 35 DC        | 1.1  | 0.034 | 20 | 12  | 20              |
| 012       |                    |              | 9.9 | 47   |             |       |     |              | 1.18 | 0.044 | 25 |     |                 |
| 012       | 253/187            | 208/230-1-60 | 5.2 | 21   | 0.38        | 0.116 | 36  | 35 DC        | 1.18 | 0.044 | 25 | 9   | 15              |
| 018       |                    |              | 7.3 | 32.6 | 0.78        | 0.224 | 53  | 208/230-1-6. | 0.26 | 0.075 | 31 | 11  | 20              |
| 024       |                    |              | 9.7 | 34.8 | 0.62        | 0.218 | 100 |              | 0.39 | 0.112 | 50 | 14  | 25              |

\*Permissible limits of the voltage range at which the unit will operate satisfactorily

### LEGEND

- FLA - Full Load Amps  
 LRA - Locked Rotor Amps  
 MCA - Minimum Circuit Amps  
 RLA - Rated Load Amps

# WIRING DIAGRAMS

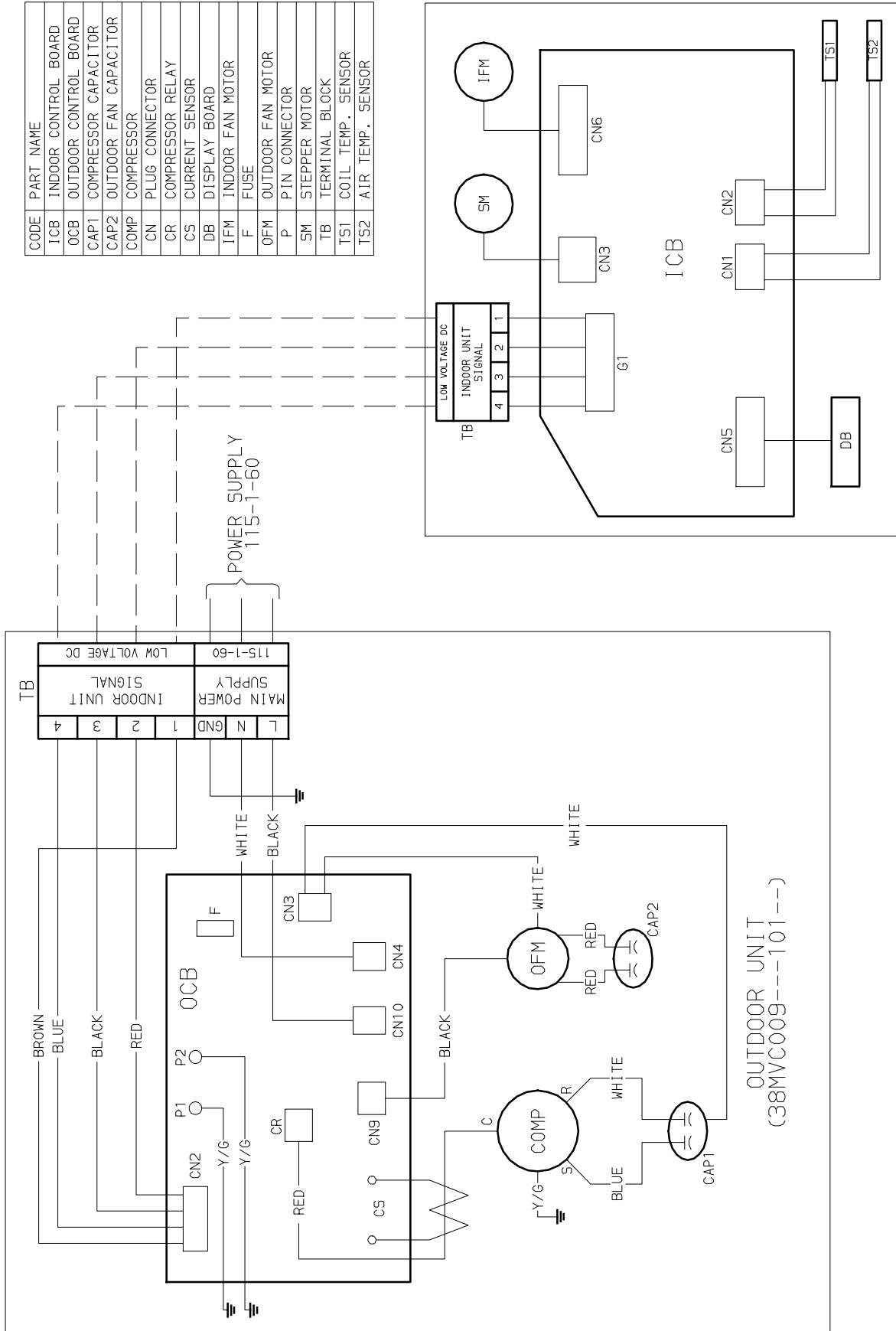

INDOOR UNIT  
(40MVC09---101---)

Fig. 5 – Wiring Diagram 38MVC09---1 W/ 40MVC09---1

WIRING DIAGRAMS (CONT.)

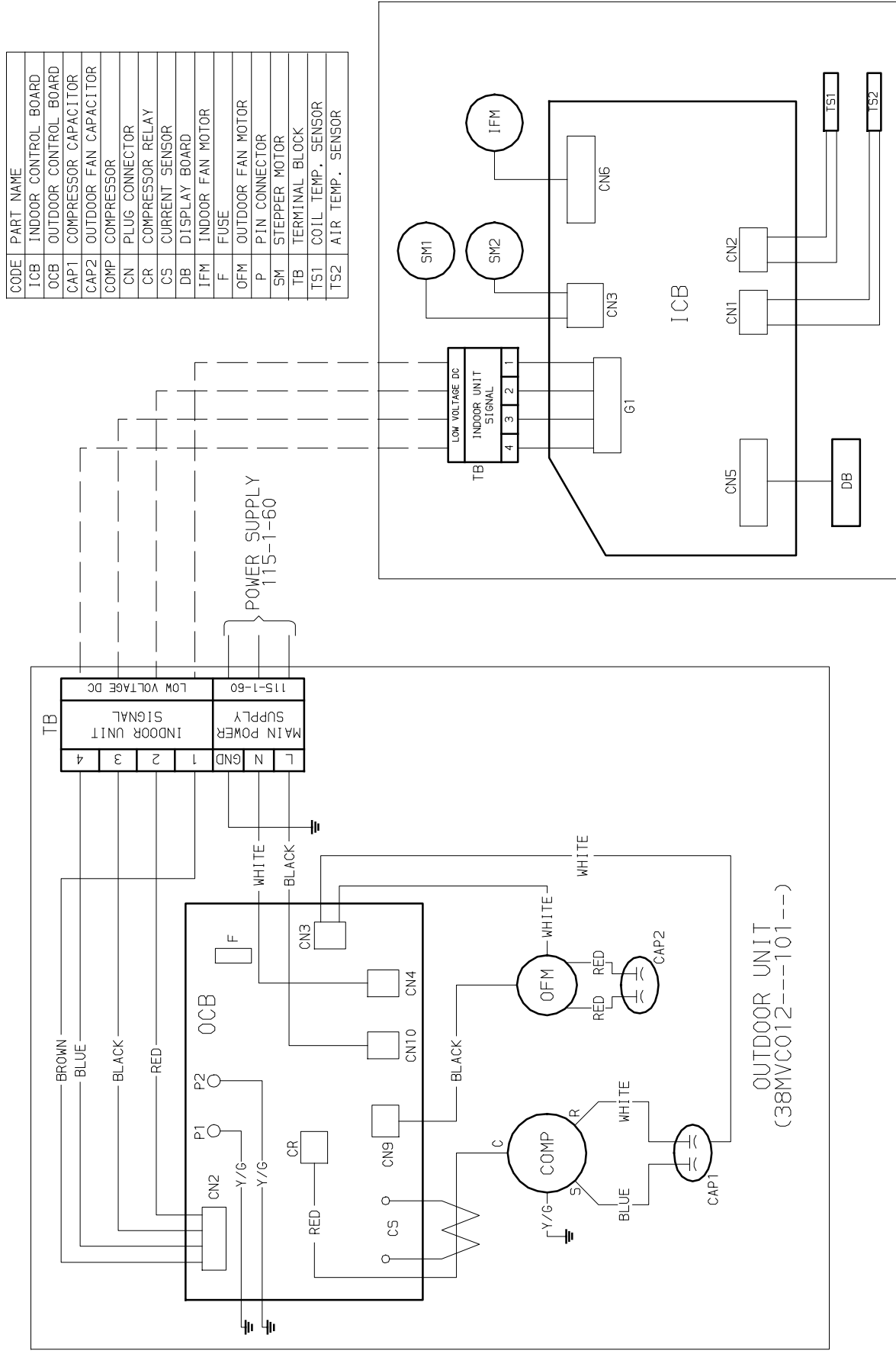

INDOOR UNIT (40MVC012) ---101---

Fig. 6 - Wiring Diagram 38MVC012---1 W/ 40MVC012---1

# WIRING DIAGRAMS (CONT.)

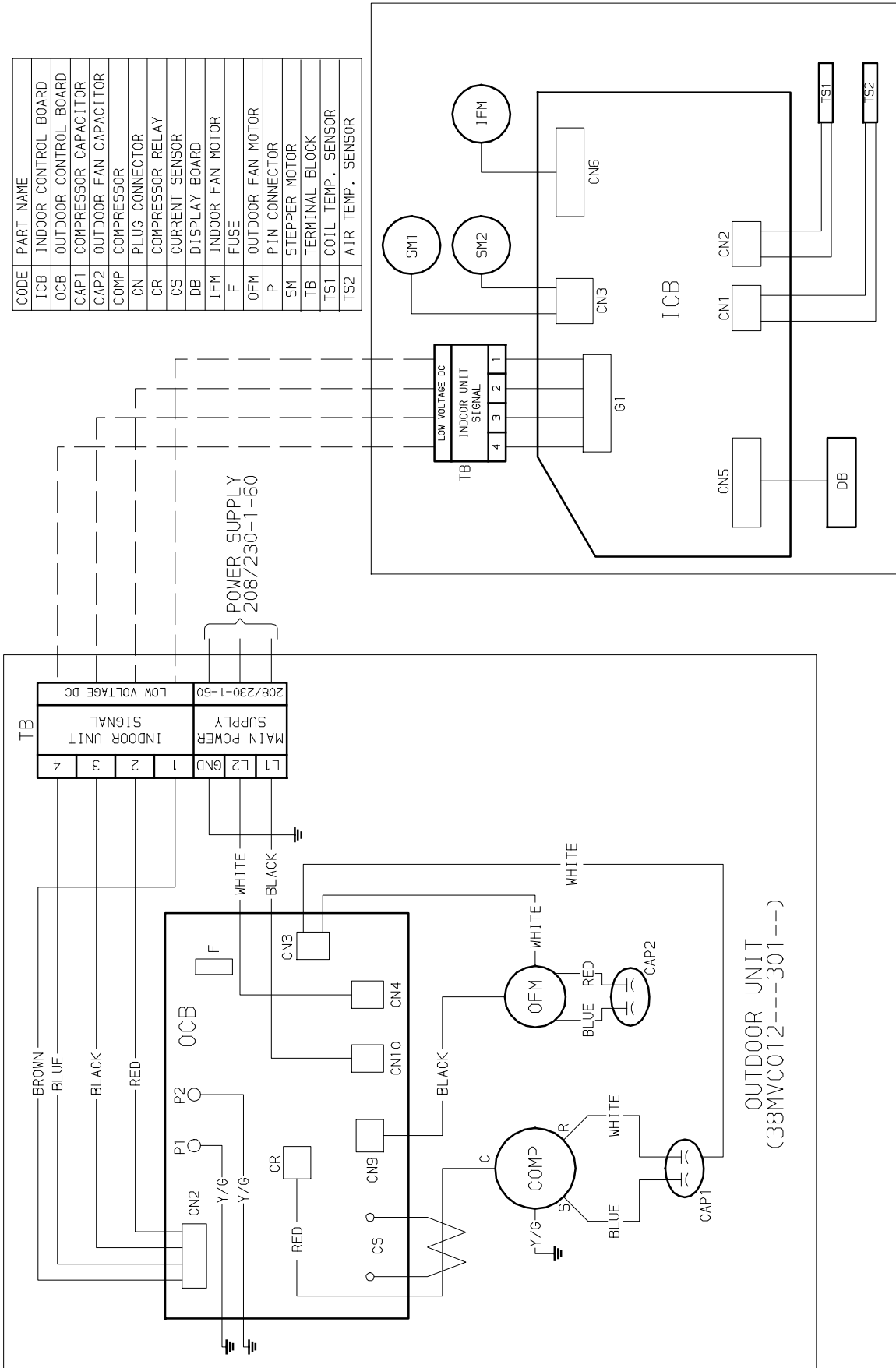

INDOOR UNIT  
(40MVC012---301---)

Fig. 7 – Wiring Diagram 38MVC012---3 W/ 40MVC012---3

WIRING DIAGRAMS (CONT.)

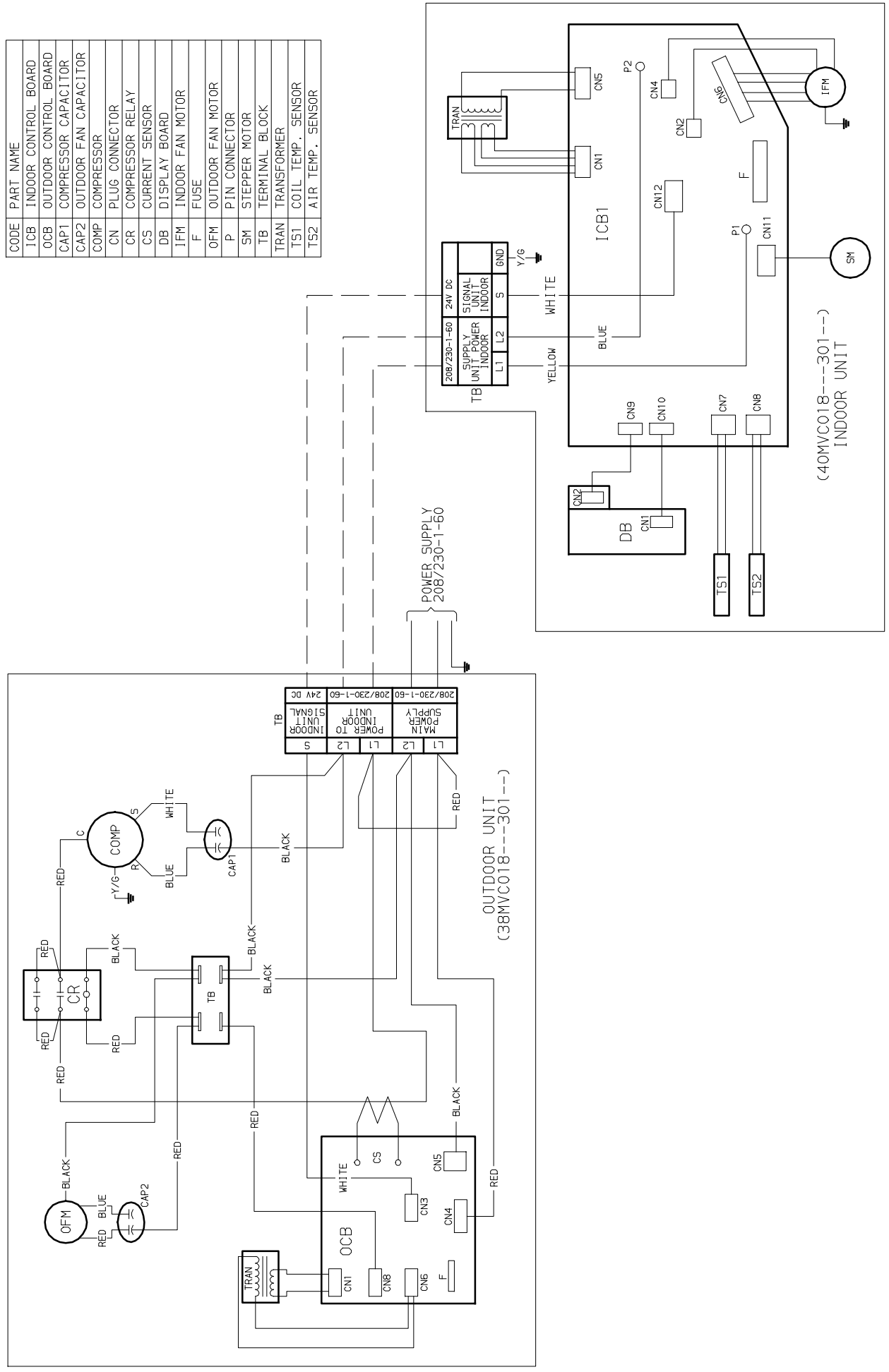

Fig. 8 - Wiring Diagram 38MVC018---3 W/ 40MVC018---3

# WIRING DIAGRAMS (CONT.)

|      |                       |
|------|-----------------------|
| CODE | PART NAME             |
| ICB  | INDOOR CONTROL BOARD  |
| OCB  | OUTDOOR CONTROL BOARD |
| CAP1 | COMPRESSOR CAPACITOR  |
| CAP2 | OUTDOOR FAN CAPACITOR |
| COMP | COMPRESSOR            |
| CN   | PLUG CONNECTOR        |
| CR   | COMPRESSOR RELAY      |
| CS   | CURRENT SENSOR        |
| DB   | DISPLAY BOARD         |
| IFM  | INDOOR FAN MOTOR      |
| F    | FUSE                  |
| OFM  | OUTDOOR FAN MOTOR     |
| P    | P.I.N CONNECTOR       |
| SM   | STEPPER MOTOR         |
| TB   | TERMINAL BLOCK        |
| TRAN | TRANSFORMER           |
| TS1  | COIL TEMP. SENSOR     |
| TS2  | AIR TEMP. SENSOR      |

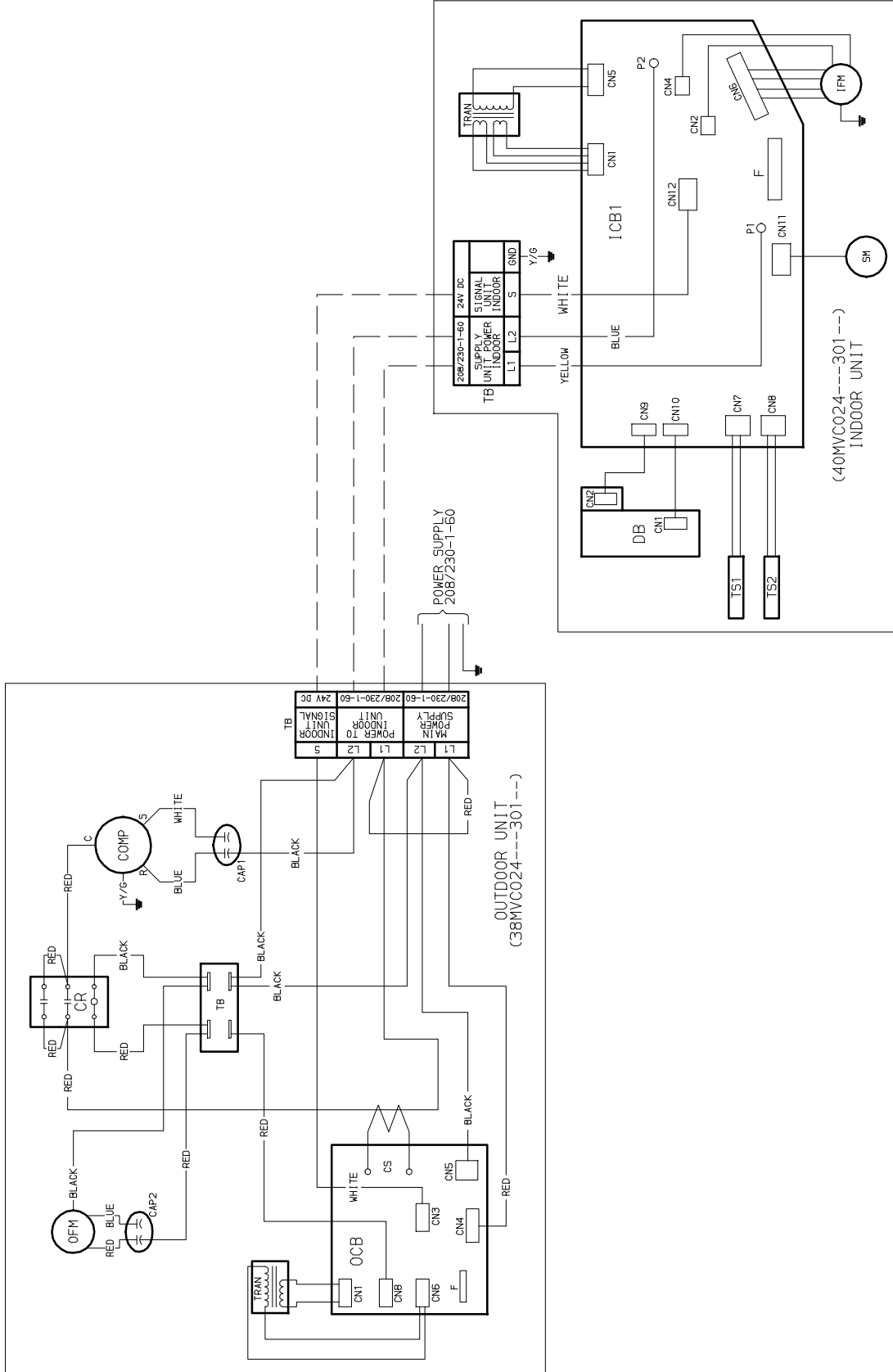
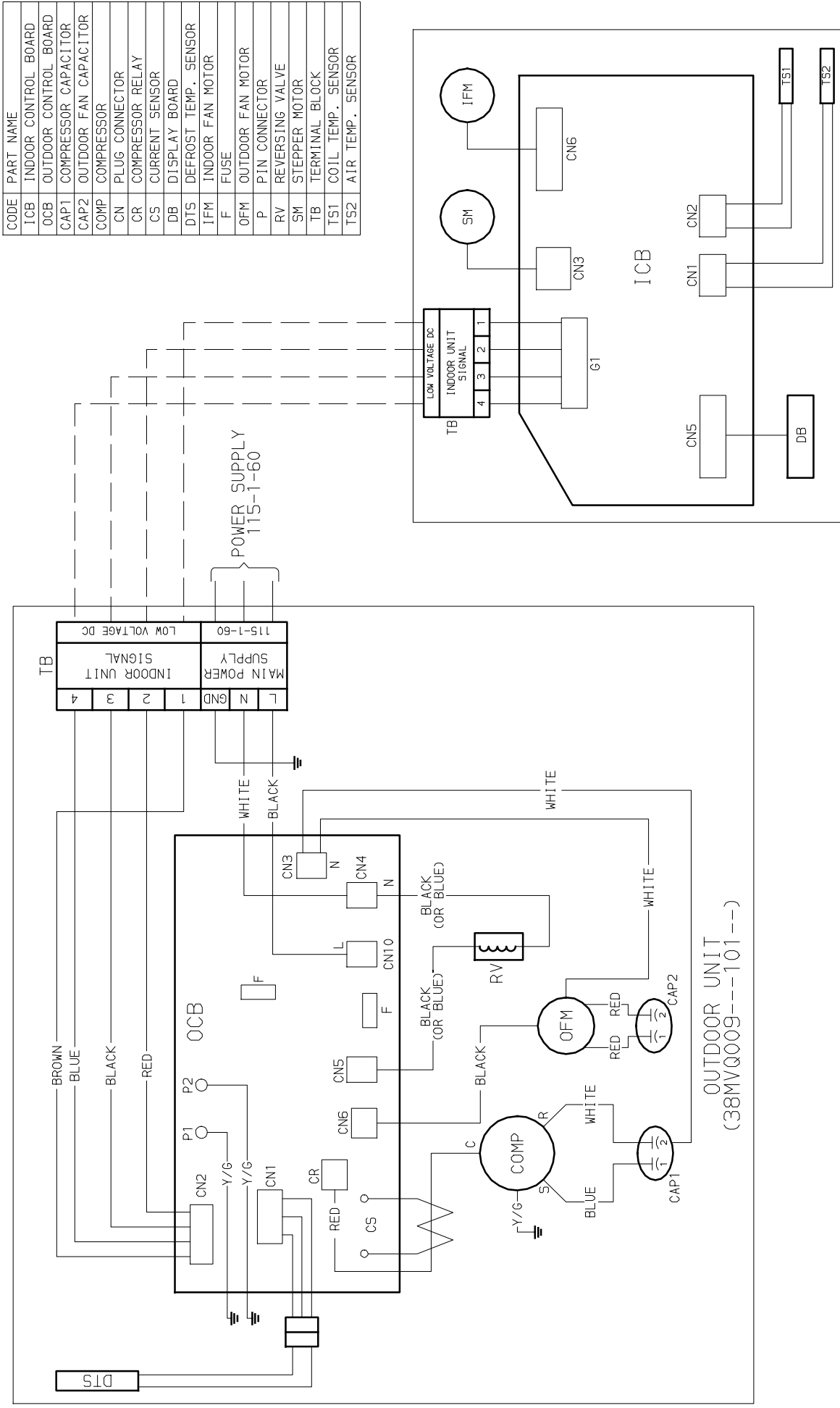

Fig. 9 – Wiring Diagram 38MVC024---3 W/ 40MVC024---3

WIRING DIAGRAMS (CONT.)



| CODE | PART NAME             |
|------|-----------------------|
| ICB  | INDOOR CONTROL BOARD  |
| OCB  | OUTDOOR CONTROL BOARD |
| CAP1 | COMPRESSOR CAPACITOR  |
| CAP2 | OUTDOOR FAN CAPACITOR |
| COMP | COMPRESSOR            |
| CN   | PLUG CONNECTOR        |
| CR   | COMPRESSOR RELAY      |
| CS   | CURRENT SENSOR        |
| DB   | DISPLAY BOARD         |
| DTS  | DEFROST TEMP. SENSOR  |
| IFM  | INDOOR FAN MOTOR      |
| F    | FUSE                  |
| OFM  | OUTDOOR FAN MOTOR     |
| P    | PIN CONNECTOR         |
| RV   | REVERSING VALVE       |
| SM   | STEPPER MOTOR         |
| TB   | TERMINAL BLOCK        |
| TS1  | COIL TEMP. SENSOR     |
| TS2  | AIR TEMP. SENSOR      |

INDOOR UNIT  
(40MVQ009---101---)

Fig. 10 - Wiring Diagram 38MVQ009---1 W/ 40MVQ009---1

# WIRING DIAGRAMS (CONT.)

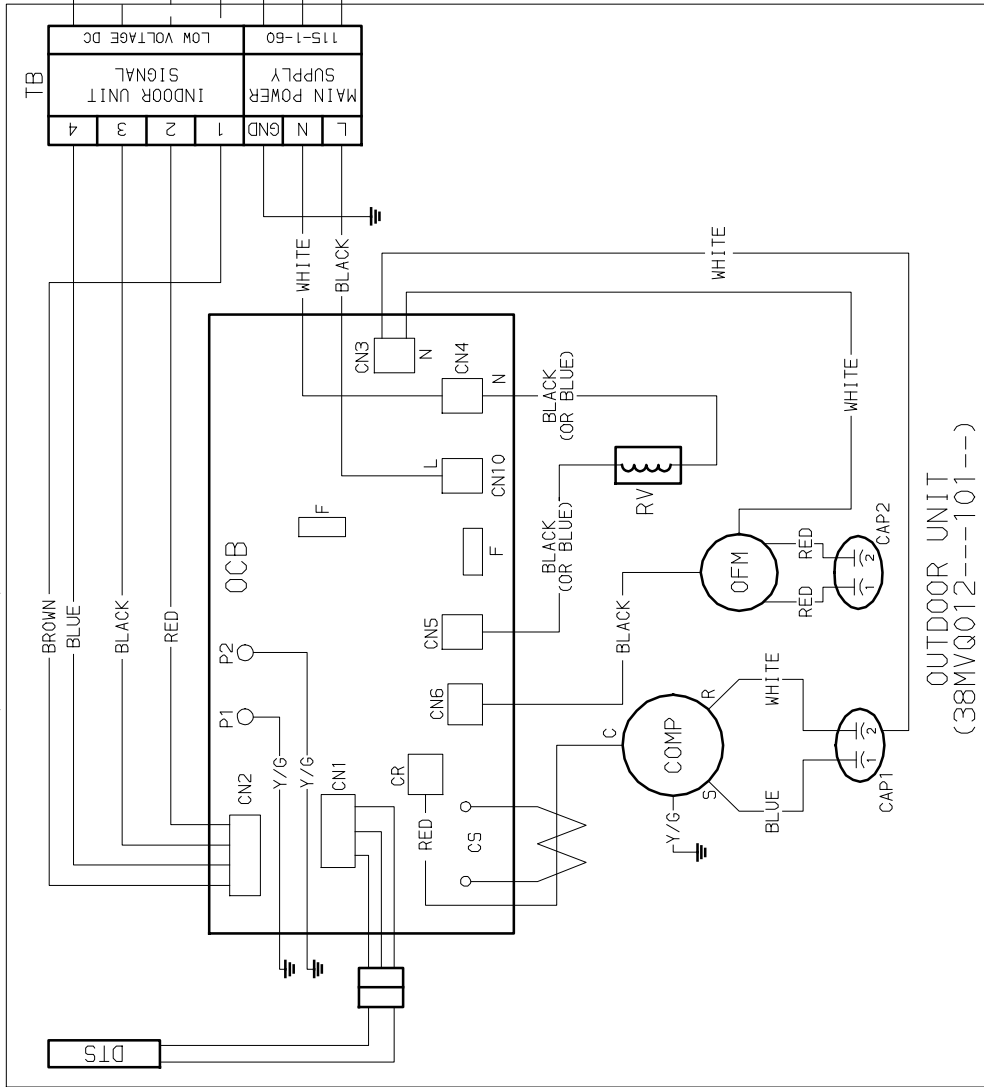

| CODE | PART NAME             |
|------|-----------------------|
| ICB  | INDOOR CONTROL BOARD  |
| OCB  | OUTDOOR CONTROL BOARD |
| CAP1 | COMPRESSOR CAPACITOR  |
| CAP2 | OUTDOOR FAN CAPACITOR |
| COMP | COMPRESSOR            |
| CN   | PLUG CONNECTOR        |
| CR   | COMPRESSOR RELAY      |
| CS   | CURRENT SENSOR        |
| DB   | DISPLAY BOARD         |
| IFM  | INDOOR FAN MOTOR      |
| F    | FUSE                  |
| OFM  | OUTDOOR FAN MOTOR     |
| P    | PIN CONNECTOR         |
| SM   | STEPPER MOTOR         |
| TB   | TERMINAL BLOCK        |
| TS1  | COIL TEMP. SENSOR     |
| TS2  | AIR TEMP. SENSOR      |

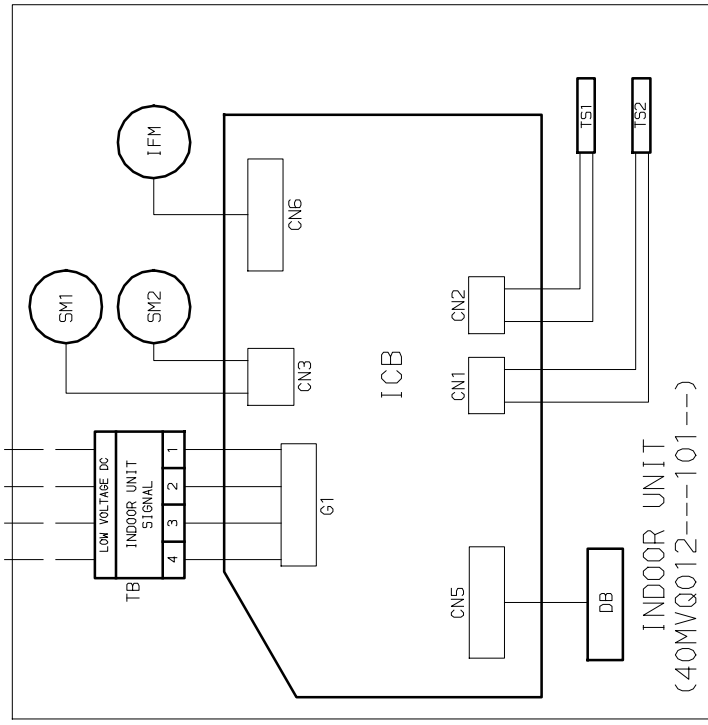

Fig. 11 – Wiring Diagram 38MVQ012---1 W/ 40MVQ012---1

WIRING DIAGRAMS (CONT.)

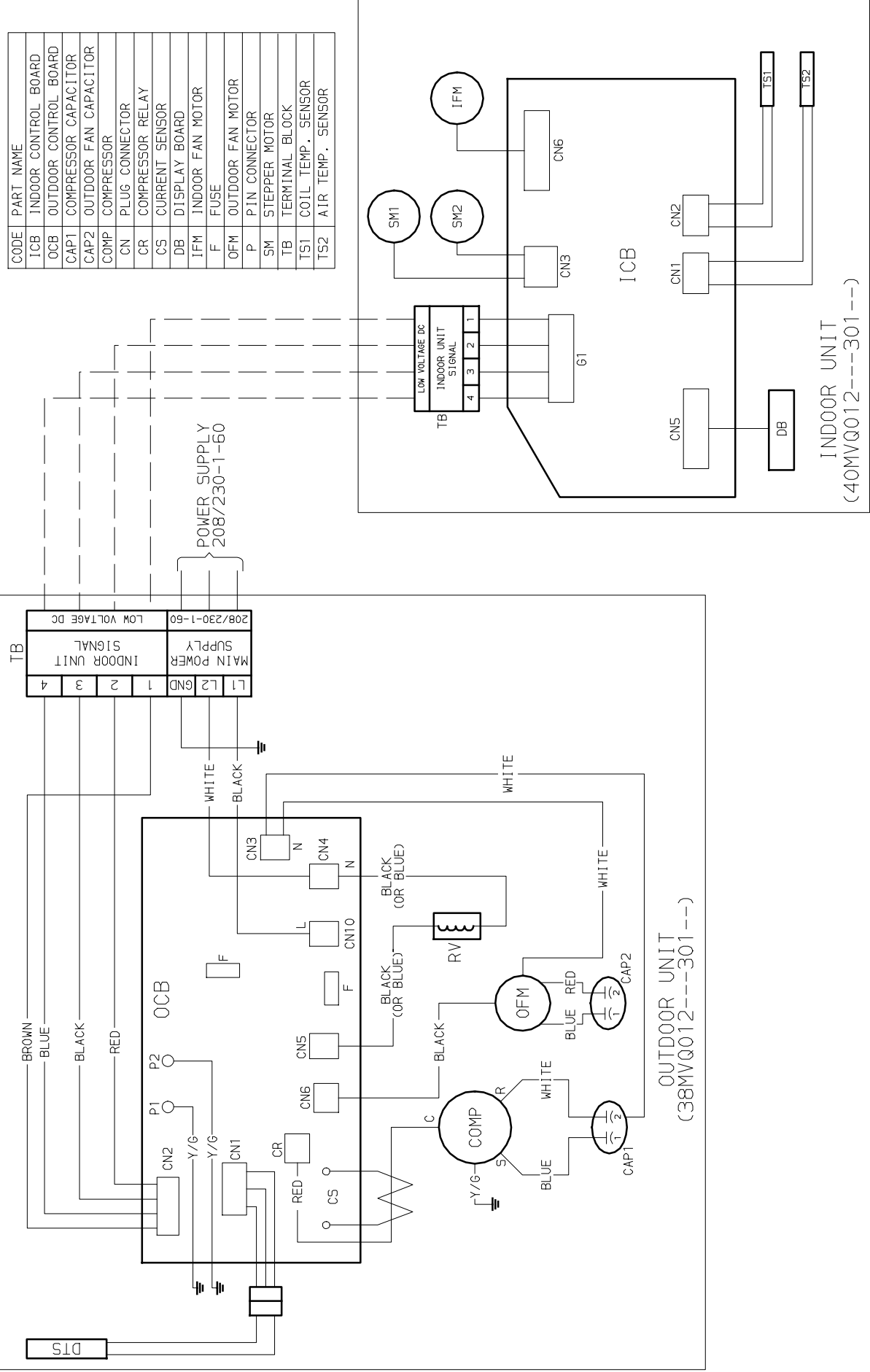
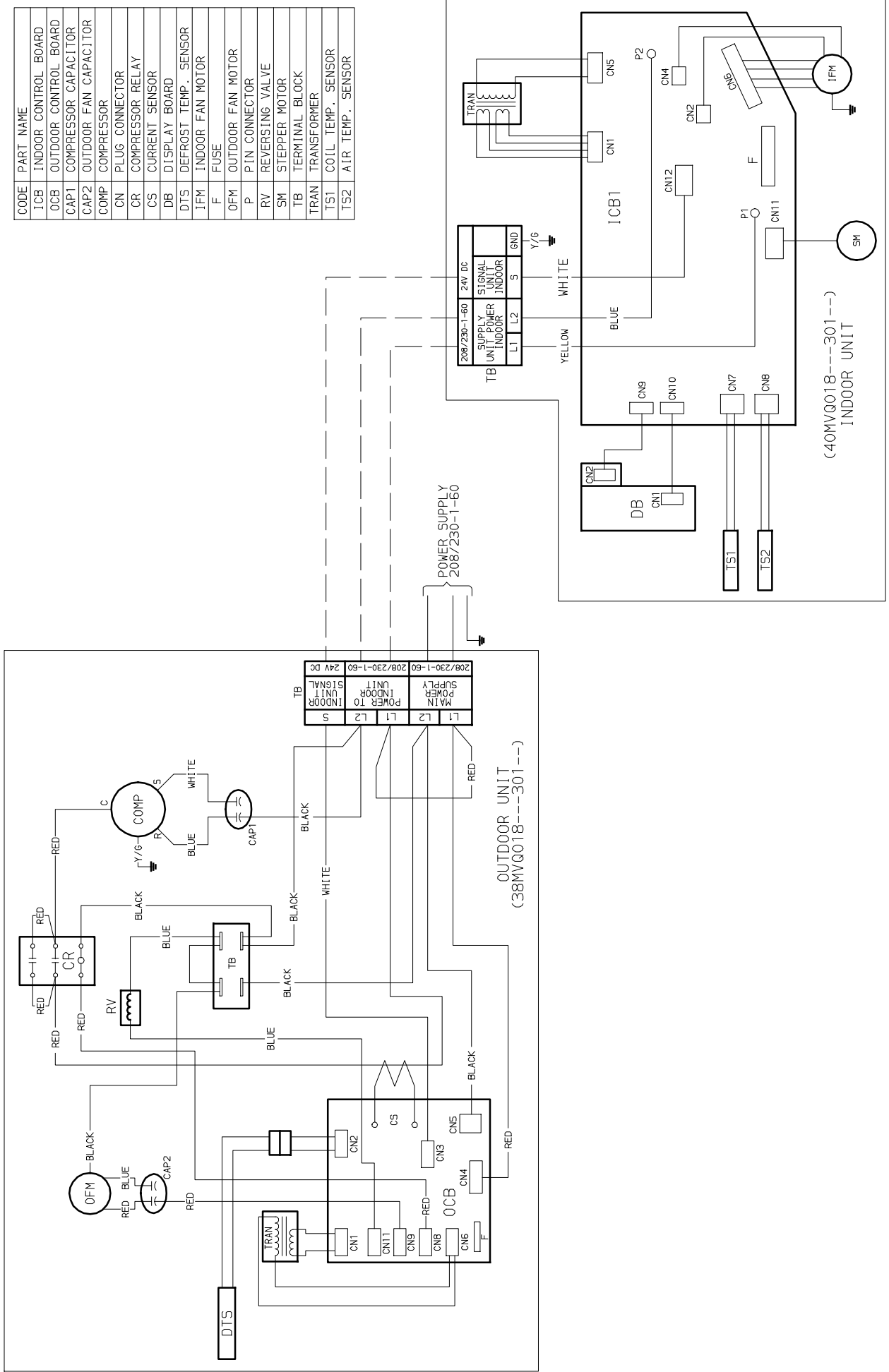

Fig. 12 - Wiring Diagram 38MVQ012---3 W/ 40MVQ012---3

# WIRING DIAGRAMS (CONT.)



| CODE | PART NAME             |
|------|-----------------------|
| ICB  | INDOOR CONTROL BOARD  |
| OCB  | OUTDOOR CONTROL BOARD |
| CAP1 | COMPRESSOR CAPACITOR  |
| CAP2 | OUTDOOR FAN CAPACITOR |
| COMP | COMPRESSOR            |
| CN   | PLUG CONNECTOR        |
| CR   | COMPRESSOR RELAY      |
| CS   | CURRENT SENSOR        |
| DB   | DISPLAY BOARD         |
| DTS  | DEFROST TEMP. SENSOR  |
| IFM  | INDOOR FAN MOTOR      |
| F    | FUSE                  |
| OFM  | OUTDOOR FAN MOTOR     |
| P    | PIN CONNECTOR         |
| RV   | REVERSING VALVE       |
| SM   | STEPPER MOTOR         |
| TB   | TERMINAL BLOCK        |
| TRAN | TRANSFORMER           |
| TS1  | COIL TEMP. SENSOR     |
| TS2  | AIR TEMP. SENSOR      |

Fig. 13 – Wiring Diagram 38MVQ018----3 W/ 40MVQ018----3

WIRING DIAGRAMS (CONT.)

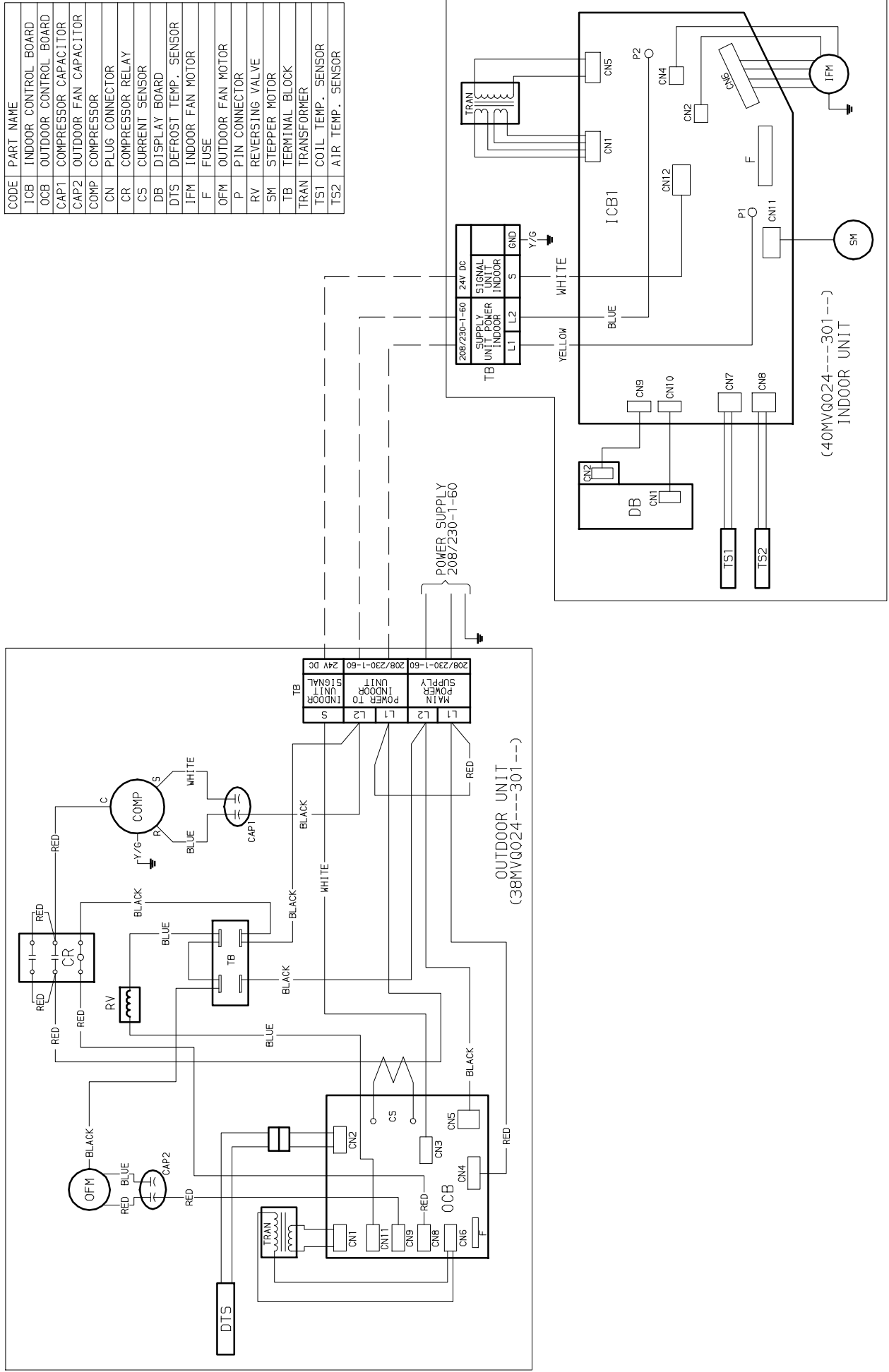

| CODE | PART NAME             |
|------|-----------------------|
| ICB  | INDOOR CONTROL BOARD  |
| OCB  | OUTDOOR CONTROL BOARD |
| CAP1 | COMPRESSOR CAPACITOR  |
| CAP2 | OUTDOOR FAN CAPACITOR |
| COMP | COMPRESSOR            |
| CN   | PLUG CONNECTOR        |
| CR   | COMPRESSOR RELAY      |
| CS   | CURRENT SENSOR        |
| DB   | DISPLAY BOARD         |
| DTS  | DEFROST TEMP. SENSOR  |
| IFM  | INDOOR FAN MOTOR      |
| F    | FUSE                  |
| OFM  | OUTDOOR FAN MOTOR     |
| P    | PIN CONNECTOR         |
| RV   | REVERSING VALVE       |
| SM   | STEPPER MOTOR         |
| TB   | TERMINAL BLOCK        |
| TRAN | TRANSFORMER           |
| TS1  | COIL TEMP. SENSOR     |
| TS2  | AIR TEMP. SENSOR      |

Fig. 14 - Wiring Diagram 38MVQ024----3 W/ 40MVQ024----3

# GUIDE SPECIFICATIONS

## INDOOR WALL-MOUNTED DUCT-FREE UNITS

Size Range: 3/4 to 2 Ton Nominal Cooling Capacity / 3/4 to 2 Ton Nominal Heating Capacity  
Carrier Model Number: 40MVC/40MVQ

### PART 1 - GENERAL

#### 1.01 System Description

Indoor, wall-mounted, direct-expansion fan coils are matched with cooling only or heat pump outdoor unit .

#### 1.02 Agency Listings

Unit shall be rated per ARI Standards 210/240 and listed in the ARI directory as a matched system.

#### 1.03 Delivery, Storage, And Handling

Units shall be stored and handled per unit manufacturer's recommendations.

#### 1.04 Warranty (For Inclusion By Specifying Engineer)

### PART 2 - PRODUCTS

#### 2.01 Equipment

##### **A. General:**

Indoor, direct-expansion, wall-mounted fan coil. Unit shall be complete with cooling/heating coil, fan, fan motor, piping connectors, electrical controls, microprocessor control system, and integral temperature sensing. Unit shall be furnished with integral wall mounting bracket and mounting hardware.

##### **B. Unit Cabinet:**

Cabinet discharge and inlet grilles shall be attractively styled, high-impact polystyrene. Cabinet shall be fully insulated for improved thermal and acoustic performance.

##### **C. Fans:**

1. Fan shall be tangential direct-drive blower type with air intake at the top of the unit and discharge at the bottom front. Automatic, motor-driven vertical air sweep shall be provided standard.
2. Air sweep operation shall be user selectable. The vertical sweep may be adjusted (using the remote control) and the horizontal air direction may be set manually.

##### **D. Coil:**

Coil shall be copper tube with aluminum fins and galvanized steel tube sheets. Fins shall be bonded to the tubes by mechanical expansion. A drip pan under the coil shall have a drain connection for hose attachment to remove condensate. Condensate pan shall have internal trap.

##### **E. Motors:**

Motors shall be open drip-proof, permanently lubricated ball bearing with inherent overload protection. Fan motors shall be 3-speed.

##### **F. Controls:**

Controls shall consist of a microprocessor-based control system which shall control space temperature, determine optimum fan speed, and run self diagnostics. the temperature control range shall be from 62°F to 84°F (16.67°C to 28.89°C).

##### **The unit shall have the following functions as a minimum:**

1. An automatic restart after power failure at the same operating conditions as at failure.
2. A timer function to provide a minimum 24-hour timer cycle for system Auto Start/Stop.
3. Temperature-sensing controls shall sense return air temperature.
4. Indoor coil freeze protection.
5. Wireless infrared remote control to enter set points and operating conditions.
6. Automatic air sweep control to provide on or off activation of air sweep louvers.
7. Dehumidification mode shall provide increased latent removal capability by modulating system operation and set point temperature.
8. Fan-only operation to provide room air circulation when no cooling is required.
9. Diagnostics shall provide continuous checks of unit operation and warn of possible malfunctions. Error messages shall be displayed at the unit.
10. Fan speed control shall be user-selectable: high, medium, low, or microprocessor controlled automatic operation during all operating modes.
11. Automatic heating-to-cooling changeover in heat pump mode. Control shall include deadband to prevent rapid mode cycling between heating and cooling.
12. Indoor coil high temperature protection shall be provided to detect excessive indoor discharge temperature when unit is in heat pump mode.

##### **G. Filters:**

Unit shall have filter track with factory-supplied cleanable filters.

##### **H. Electrical Requirements:**

Indoor fan motor to operate on 35VDC on model sizes 009-012 and on 208-230v on model sizes 018-024, power is supplied from outdoor unit.

##### **I. Operating Characteristics:**

The 40MVC, MVQ system shall have a minimum listed SEER (seasonal energy efficiency ratio) of 13 at ARI conditions, and a minimum HSPF of 7.7.

##### **J. Refrigerant Lines:**

All units should have refrigerant lines that can be oriented to connect from the left, right or back of unit. Both refrigerant lines need to be insulated.

##### **K. Special Features (Field Installed):**

1. Condensate Pump:
  - The condensate pump shall remove condensate from the drain pan when gravity drainage cannot be used. Pump shall be designed for quiet operation. Pump shall consist of two parts: an internal reservoir/sensor assembly, and a remote sound-shielded pump assembly. A liquid level sensor in the reservoir shall stop cooling operation if the liquid level in the reservoir is unacceptable.

# GUIDE SPECIFICATIONS

## HORIZONTAL DISCHARGE OUTDOOR UNITS

Size Range: 3/4 to 2 Ton Nominal Cooling Capacity / 3/4 to 2 Ton Nominal Heating Capacity  
Carrier Model Number: 38MVC/38MVQ

### PART 1 - GENERAL

#### 1.01 System Description

- A. Outdoor air-cooled split system compressor sections suitable for on-the-ground, rooftop, wall hung or balcony mounting. Units shall consist of a rotary compressor, an air-cooled coil, propeller-type draw-through outdoor fan, reversing valve (HP), accumulator (HP units), metering device(s), and control box. Units shall discharge air horizontally as shown on the contract drawings. Units shall function as the outdoor component of an air-to-air cooling only, or heat pump system.
- B. Units shall be used in a refrigeration circuit matched to duct-free cooling only or heat pump fan coil units.

#### 1.02 Agency Listings

- A. Unit construction shall comply with ANSI/ASHRAE 15, latest revision, and with the NEC.
- B. Units shall be evaluated in accordance with UL standard 1995.
- C. Units shall be listed in the CEC directory.
- D. Unit cabinet shall be capable of withstanding 500-hour salt spray test per Federal Test Standard No. 141 (method 6061).
- E. Air-cooled condenser coils shall be leak tested at 573 psig.

#### 1.03 Delivery, Storage, And Handling

Units shall be shipped in one piece and shall be stored and handled per unit manufacturer's recommendations.

#### 1.04 Warranty (For Inclusion By Specifying Engineer)

### PART 2 - PRODUCTS

#### 2.01 Equipment

##### A. General:

Factory assembled, single piece, air-cooled outdoor unit. Contained within the unit enclosure shall be all factory wiring, piping, controls, and the compressor.

##### B. Unit Cabinet:

- Unit cabinet shall be constructed of galvanized steel, bonderized and coated with a baked-enamel finish on inside and outside.
- Unit access panels shall be removable with minimal screws and shall provide full access to the compressor, fan, and control components.
- Outdoor compartment shall be isolated and have an acoustic lining to assure quiet operation.

##### C. Fans:

- Outdoor fans shall be direct-drive propeller type, and shall discharge air horizontally. Fans shall draw air through the outdoor coil.
- Outdoor fan motors shall be totally-enclosed, single phase motors with class B insulation and permanently-lubricated ball bearings. Motor shall be protected by internal thermal overload protection.
- Shaft shall have inherent corrosion resistance.
- Fan blades shall be non metallic and shall be statically and dynamically balanced.
- Outdoor fan openings shall be equipped with PVC metal/mesh coated protection grille over fan.

##### D. Compressor:

- Compressor shall be fully hermetic rotary type.
- Compressor shall be equipped with oil system, operating oil charge, and motor. Internal overloads shall protect the compressor from over-temperature and over-current.
- Motor shall be NEMA rated class F, suitable for operation in a refrigerant atmosphere.
- Compressor assembly shall be installed on rubber vibration isolators.
- Compressors shall be single phase.

##### E. Outdoor Coil:

Coil shall be constructed of aluminum fins mechanically bonded to seamless copper tubes, which are cleaned, dehydrated, and sealed.

##### F. Refrigeration Components:

Refrigerant circuit components shall include brass external liquid line service valve with service gage port connections, suction line service valve with service gage connection port, service gage port connections on compressor suction and discharge lines with Schrader type fittings with brass caps, accumulator, reversing valve.

##### G. Controls and Safeties:

Operating controls and safeties shall be factory selected, assembled, and tested. The minimum control functions shall include the following:

- Controls:
  - A time delay control sequence is provided standard through the fan coil board.
  - Automatic outdoor-fan motor protection.
- Safeties:
  - System diagnostics.
  - Compressor motor current and temperature overload protection.
  - Outdoor fan failure protection.

##### H. Electrical Requirements:

- Unit shall operate on single-phase, 60 Hz power at 115 v for unit sizes 009-012 and 208/230v for unit sizes 012, 018, and 024, as specified.
- Unit electrical power shall be a single point connection.
- Unit control voltage to the indoor-fan coil shall be 24 VDC.
- All power and control wiring must be installed per NEC and all local electrical codes.
- Unit shall have high- and low-voltage terminal block connections.

##### I. Special Features (Field Installed):

- Low-Ambient Kit: Control shall regulate fan-motor cycles in response to saturated condensing temperature of the unit. The control shall be capable of maintaining a condensing temperature of 100°F ± 10°F (37.78°C ± 10-12./22°C) with outdoor temperatures to -20°F (-28.9°C). Installation of kit shall not require changing the outdoor fan motor.
- Crankcase Heater
- Wind baffle (field fabricated)