

HRVCLHA, HRVCCSVA, HRVCCSHA Heat Recovery Ventilators

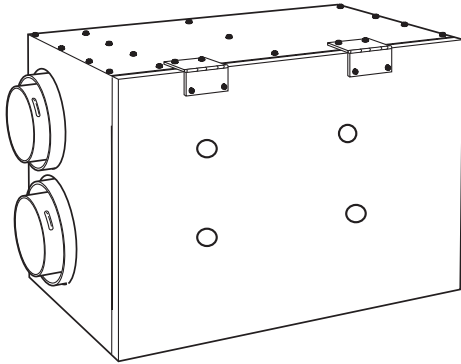

Turn to the Experts.™

Product Data



HRVCLHA

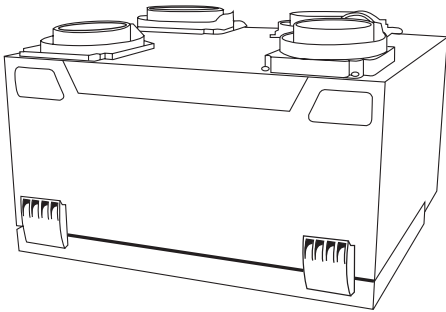

HRVCCSVA

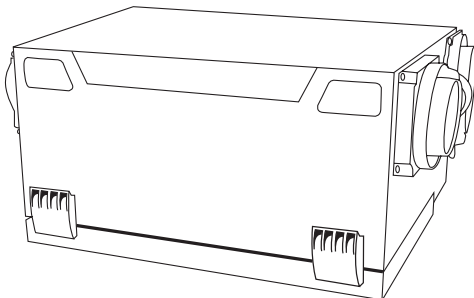

HRVCCSHA

The Heat Recovery Ventilation (HRV) system offered by Carrier is the finest on the market today. The HRV provides efficient and cost effective heat recovery during the heating season when needed most.

As temperatures drop below 23°F (-5°C), indoor air is recirculated periodically through the heat exchanger core to prevent frost from forming. Competitors' methods of supplementary electric defrost waste energy. Unlike rotary wheel heat exchangers which mix air streams, these cross-flow or counterflow heat exchangers ensure that there is no mixing of the stale air stream with the fresh outdoor air stream.

A filter installed on the incoming outdoor air stream removes large airborne particles from the intake air stream before they enter the heat exchanger and reduces the maintenance required. The units' acoustically engineered design makes the Carrier HRV the quietest on the market and ensures that comfort is felt, not heard.

Unlatching two (2) suitcase style latches allows easy removal of the filters and core for cleaning.

NOTE: The HRV should not be installed in an attic or unconditioned space unless provisions are made for drainline freezing and condensation.

STANDARD FEATURES

- Energy saving defrost cycle
- Cross-flow, counterflow heat exchangers
- One filter on incoming air; one filter on outgoing air to protect core
- Acoustical design
- No-tools maintenance
- Polypropylene heat exchanger core

Model number nomenclature

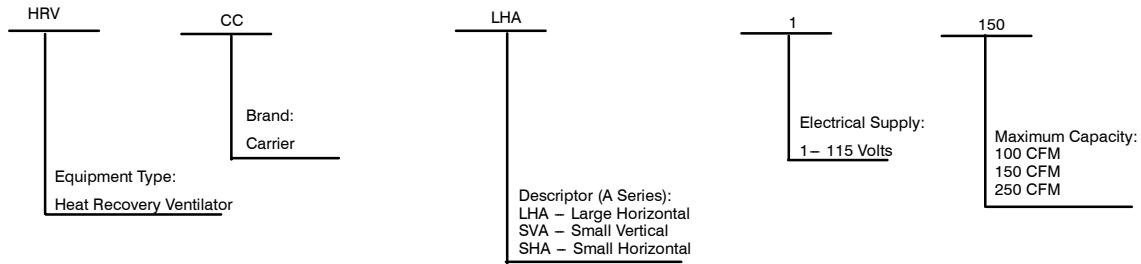

HRV

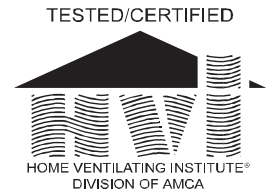

Climate Map for Energy and Heat Recovery Ventilators

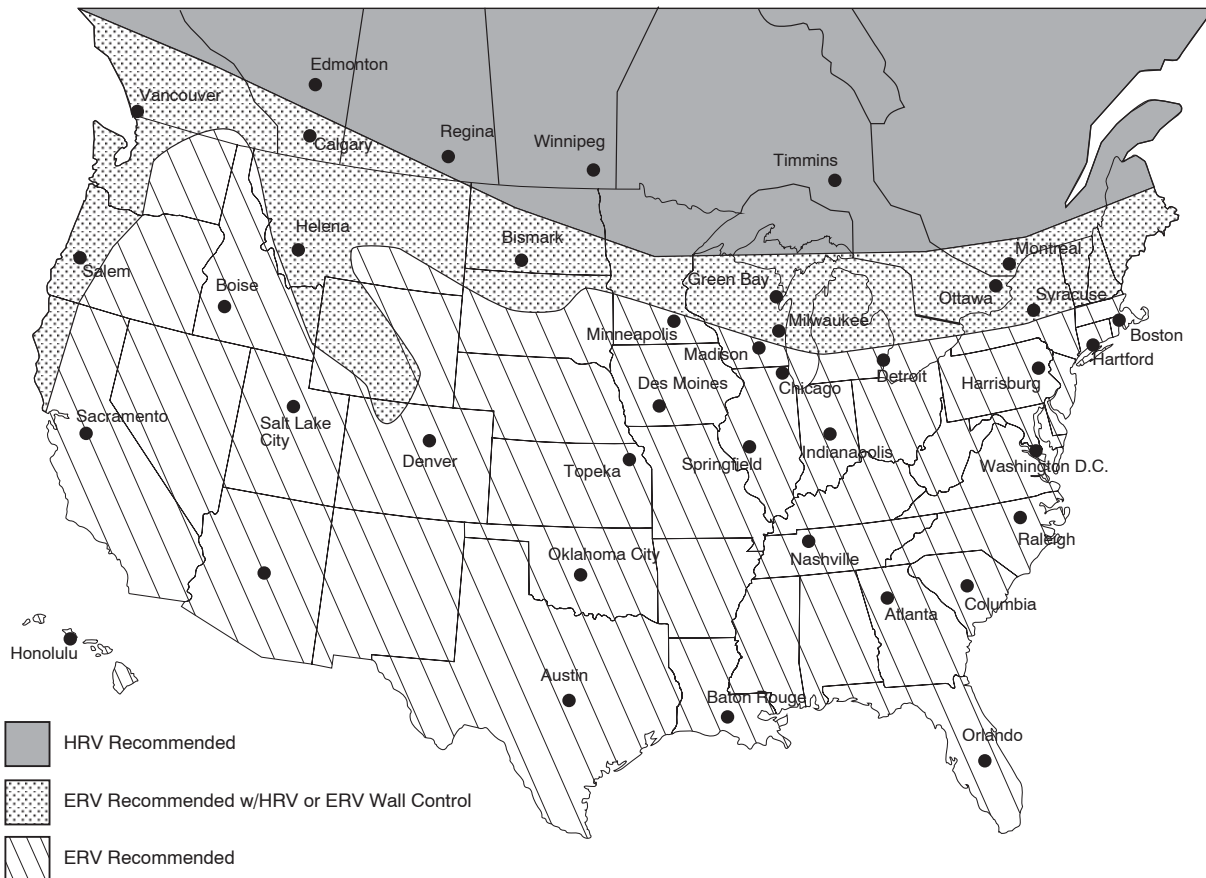

Controls and accessories part number nomenclature

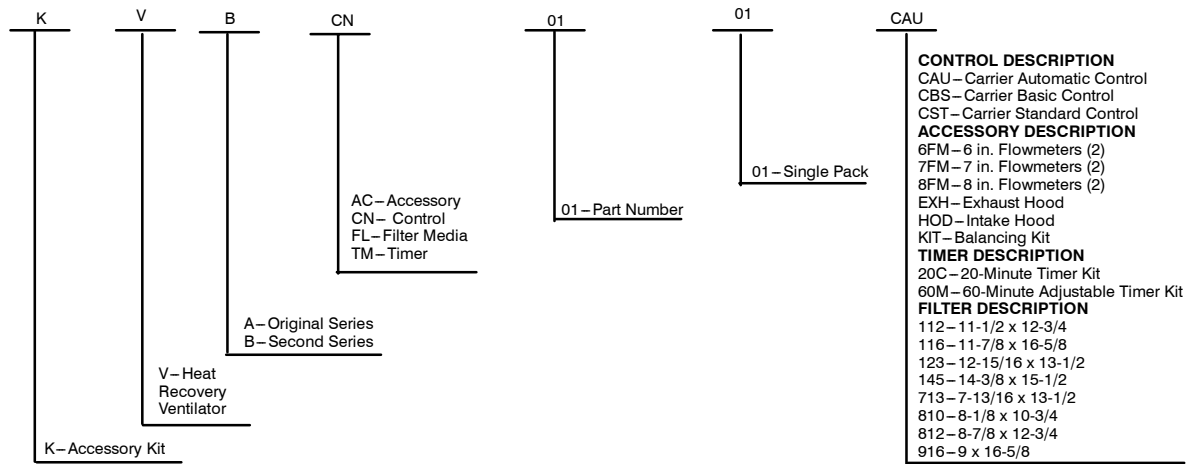

HRV

Kit Number	Description	Where Used
KVBCN0101CBS	Basic HRV Control	Used with all HRVs
KVBCN0101CST	Standard HRV Control	Used with all HRVs
KVBCN0101CLT	Carrier OneTouch Control	Used with all HRVs as a main wall control
KVAAC0101HCO	Intake and Exhaust Hood	Used as a single intake/exhaust for HRVCCSVA1100, HRVCCSHA1100 only.
KVAAC0101HOD	Exterior Intake and Exhaust Hood	2 Required
KVATM010120C	20 Minute Push Button Timer	Used with all HRVs when 20 minute manual operation is required
KVATM010160M	60 Minute Timer	Used with all HRVs, time is adjustable between 10 and 60 minutes
KVAAC0101KIT	Start-Up Balancing Kit	Start up Balancing Kit, includes (2) 6 in. Flow Meter Collars & Magnehelic Gage
KVAAC01016FM	6 in. Flow Meter Collar	At start up, when 6 in. duct work is connected to HRV
KVAAC01017FM	7 in. Flow Meter Collar	At start up, when 7 in. duct work is connected to HRV
KVAAC01018FM	8 in. Flow Meter Collar	At start up, when 8 in. duct work is connected to HRV
KVAFK0101100	Internal Filter	Used with HRVCCSHA1100, HRVCCSVA1100 Unit 10 1/2 in. x 6 3/4 in. x 1/2 in.
KVAFK0201150	Internal Filter	Used with HRVCCLHA1150, HRVCCLHA1250 Unit 15 1/2 in. x 7 in. x 5/8 in.

Control Description	Fan Speed Control	Dehumidistat Control	Continuous Mode	Intermittent Mode
OneTouch	Yes	No	Yes	Yes
Basic	Yes	No	Yes	No
Standard	Yes	Yes	Yes	Yes

Control features

Basic Control:

Allows the user to manually set fan speed to low or high as required to maximize comfort.

Standard Control:

Offers automatic dehumidistat control and the option to select continuous or intermittent fan operation. Setting the wall control to low will activate the continuous mode.

OneTouch Control:

Allows control of ventilator with the touch of a button. This control will operate as a main wall control. The OneTouch will operate the unit in Intermittent Mode (20 minutes per hour), continuous low speed, continuous high speed, and off.

Automatic Defrost Cycle Features

All models offer a non-electric defrost cycle feature which prevents frost and ice buildup within the heat recovery core. When the outside air temperature falls below 23°F (-5°C) it is electronically sensed and the dampers close the outside air ports. This allows warm indoor air to recirculate within the heat recovery core. The frequency of this cycle increases as the outside air temperature decreases.

Model	25°F TO 55°F (-5°C TO -15°C)		4°F TO -17°F (-15.6°C TO -27.3°C)		BELOW -18°F (-27.8°C)	
	DEFROST*	EXCHANGE†	DEFROST*	EXCHANGE†	DEFROST*	EXCHANGE†
HRVCCLHA	6 Minutes	60 Minutes	6 Minutes	32 Minutes	6 Minutes	20 Minutes
HRVCCSHA	6 Minutes	60 Minutes	6 Minutes	32 Minutes	6 Minutes	20 Minutes
HRVCCSVA	6 Minutes	60 Minutes	6 Minutes	32 Minutes	6 Minutes	20 Minutes

* All defrost times are in the standard mode (as shipped)

† Time between defrost when within specified temperature range

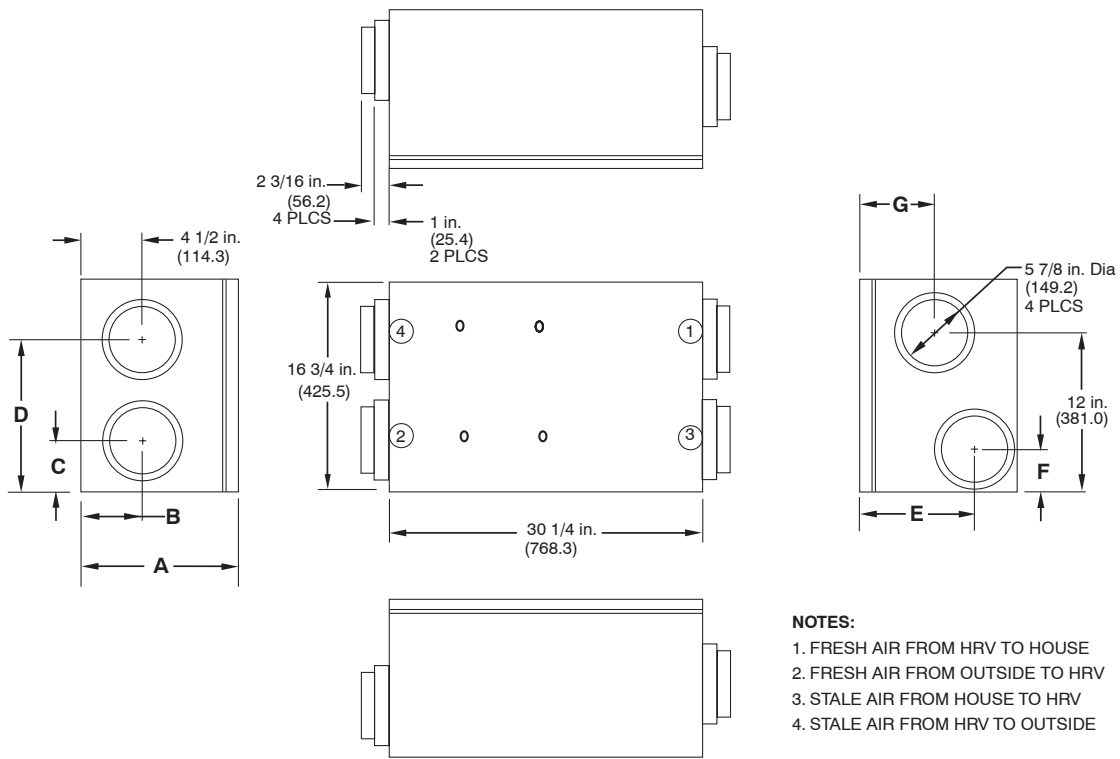

- NOTES:**
1. FRESH AIR FROM HRV TO HOUSE
 2. FRESH AIR FROM OUTSIDE TO HRV
 3. STALE AIR FROM HOUSE TO HRV
 4. STALE AIR FROM HRV TO OUTSIDE

A05228

Model	A		B		C		D	
	in.	mm	in.	mm	in.	mm	in.	mm
HRVCCLHA1150	17-1/4	438.2	10-1/2	266.7	4-1/2	114.3	11	279.4
HRVCCLHA1250	17-1/4	438.2	10-1/2	266.7	4-1/2	114.3	11	279.4

Model	E		F		G	
	in.	mm	in.	mm	in.	mm
HRVCCLHA1150	7-3/4	196.9	4-3/8	111.1	7-3/4	196.9
HRVCCLHA1250	7-3/4	196.9	5-13/16	147.6	7-3/4	196.9

Fig. 1 - HRVCCLHA Unit Dimensions

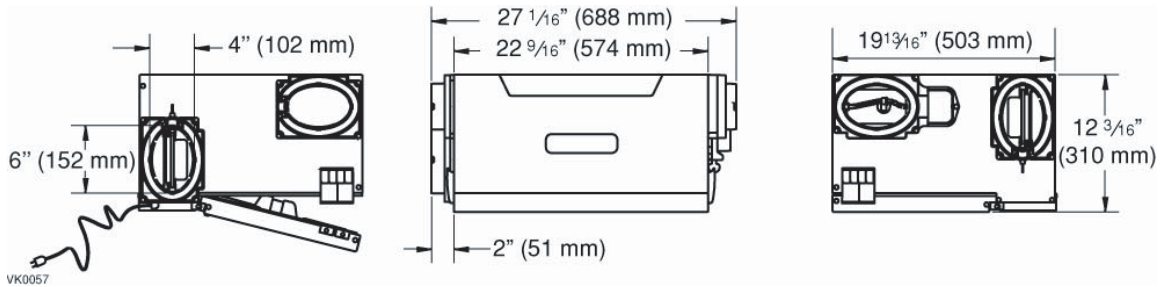

A05426

Fig. 2 - HRVCCSHA Unit Dimensions

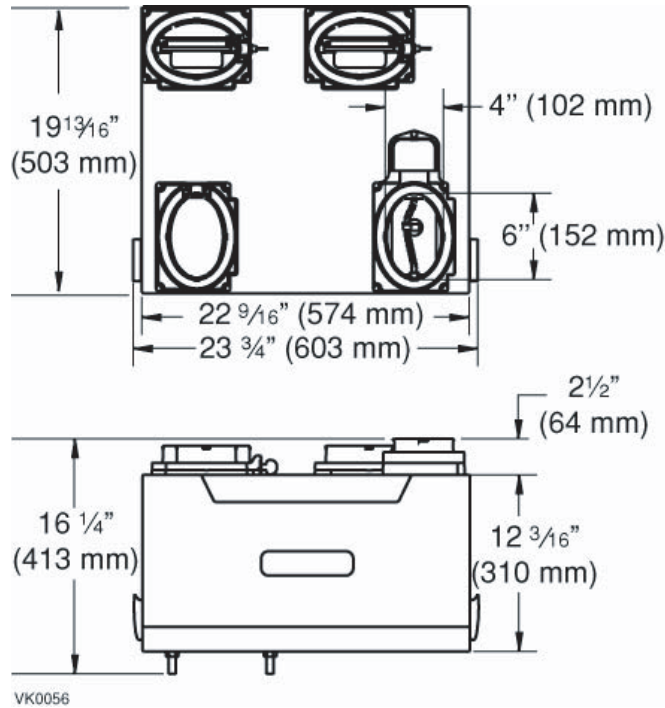

A05425

Fig. 3 - HRVCCSVA Unit Dimensions

Physical data

Model	HRVCLHA1150	HRVCLHA1250	HRVCCSVA1100	HRVCCSHA1100
Port Locations	Side	Side	Top	Side
Core Type	Polypropylene Cross Flow	Polypropylene Cross Flow	Polypropylene Cross Flow	Polypropylene Cross Flow
Weight — lb (kg)	65 (29.5)	73 (33.2)	42	42
Shipping Weight — lb (kg)	75 (34)	83 (37.6)	48	48
Shipping Dimensions (in.)				
Height	23-1/16	22-15/16	25.5	30.0
Width	36-1/16	35-1/16	17.5	15.0
Depth	17-13/16	22-15/16	23.0	23.0

Physical data (continued)

Model	HRVCCLHA1150	HRVCCLHA1250	HRVCCSVA1100	HRVCCSHA1100
Capacity—CFM @ 0.5-0.3ESP (in. wc)	130–168	191–210	99–107	99–107
Efficiency (Sensible)—Percent 32°F (0° C) –13°F (–25° C)	65 65	65 60	66 66	66 66
Efficiency (Latent)—Percent @ all temperatures	0	0	0	0
Heat Core Exchange Area— cu ft (cu m)	120 (3.4)	166 (4.7)	55 (5.1)	55 (5.1)

Model	HRVCCLHA1150	HRVCCLHA1250	HRVCCSVA1100	HRVCCSVA1100
Voltage	120	120	120	120
Max Power — watts	150	218	150	150
Max Amps	1.4	1.9	1.3	1.3

Methods to Size HRVs

HEATING LOAD BTU

Method 1:

1. Calculate cubic feet of occupied space
2. Multiply by recommended air changes per hour (AC/h)
3. Divide by 60 minutes per hour to convert to CFM

Example: 2000 sq ft with 8 ft ceiling
0.35 air changes per hour (AC/h)

$$(2000 \text{ sq ft} \times 8 \text{ ft ceiling} \times 0.35 \text{ AC/h}) / 60 \text{ min/h} = 93.3 \text{ CFM}$$

Method 2:

1. Multiply number of people times 15 CFM/person
2. Multiply number of bathrooms times 20 CFM/each
3. Add 25 CFM for kitchen

Example: 2 people
2 bathrooms
1 kitchen

$$(2 \times 15) + (2 \times 20) + 25 = 95 \text{ CFM}$$

Additional heating and cooling load charts

Although the ventilators process the outside air before it enters the home, additional heating and cooling loads need to be considered.

Outside Temp °F	Heat Load (BTUh) @ Inside Design Temp 72°F
	HRVCCLHA1150
-25	4,688
-20	4,466
-15	4,598
-10	4,334
-5	4,069
0	3,805
5	3,541
10	3,502
15	3,220
20	2,938
25	2,950
30	2,636
35	2,322
40	2,009

The heating load chart shows the heating loads in BTUh for a range of winter design temperatures for each model of ventilator.

EXAMPLE: The heating design temperature for Milwaukee, WI, is -4°F. At -5°F, the additional heating load of the HRVCCLHA1250 is 8417 BTUh. This additional load should be taken into consideration when sizing the heating equipment.

COOLING LOAD BTU

Outside Enthalpy Btu/lb	Cooling Load (BTUh) @ Inside Design Temp 75°F and 50% Relative Humidity	
	HRVCCLHA1150	HRVCCLHA1250
30	670	1,071
31	1,090	1,741
32	1,509	2,411
33	1,928	3,080
34	2,347	3,750
35	2,766	4,419
36	3,185	5,089
37	3,604	5,759
38	4,023	6,428
39	4,442	7,098
40	4,861	7,767
41	5,280	8,437
42	5,699	9,107

The cooling load chart shows the loads in BTUh also. To use the cooling load chart, first find the design enthalpy from a psychrometric chart using the design dry bulb and wet bulb temperatures. (See following psychrometric chart.) The cooling load can then be found for a range of enthalpies for each ventilator.

EXAMPLE: The cooling design dry bulb temperature for Milwaukee, WI, is 87°F and the average wet bulb at that temperature is 73°F. On the psychrometric chart the enthalpy is about 37.7 BTU/lb of dry air which will round up to 38 BTU/lb of dry air. In the left column, at 38 BTU/lb the HRVCCLHA1250 would have an additional cooling load of 6428 BTUh. This additional load should be taken into account when sizing the air cooling equipment.

HRV

HRV installed with forced air system

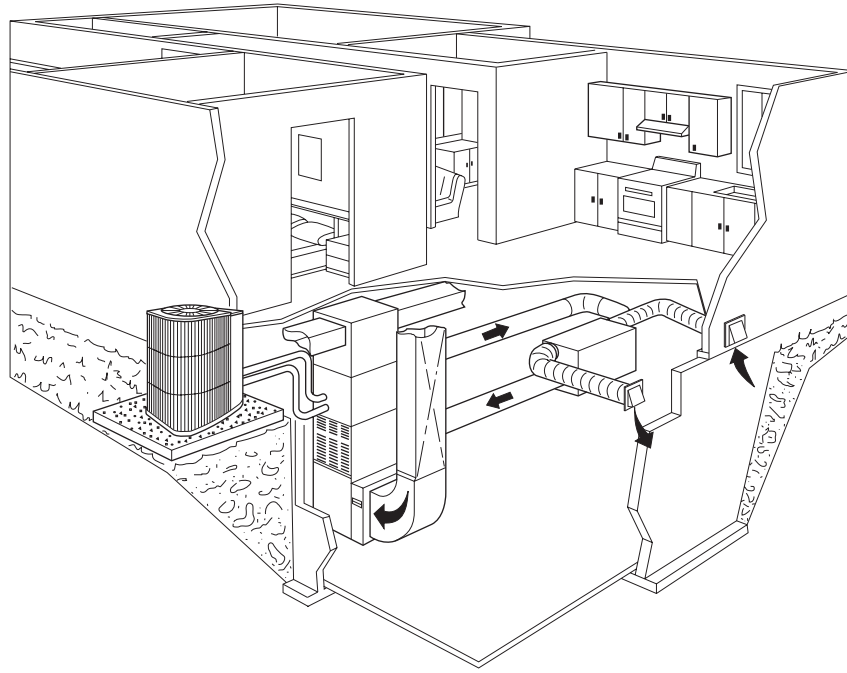

HRV

A99297

HRV installed with independent air distribution

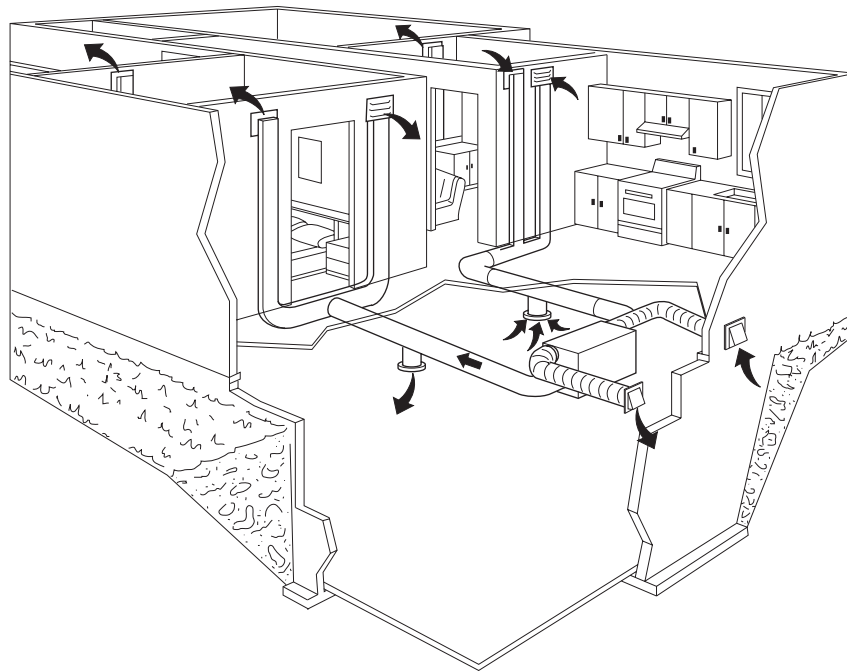

A99298