



MCX



MWX



1 - 5 T.R.



The Trane console/ceiling minisplits offer the choice of either a console or ceiling installation without the use of any supplementary accessories.

The quest for aesthetic value for good integration into the surrounding decor was considered.

An infrared remote control allows simplified control from a distance.



MCX/MWX

FOR WHOM? FOR WHAT?

To equip commercial boutiques or restaurants and public places needing a comfortable temperature and good quality of air.

Offered in cooling only or reversible.

TRANE'S ADVICE

An ideal configuration where no false ceilings are available.

Main features :

Convertible Model — Stylus™ MCX/MWX

12,000 - 36,000 Btuh (50/60 Hz)

Features:

- Convertible Installation — Floor, Ceiling or Low Wall
- 3-speed centrifugal fan motor.
- Aluminium fin heat exchanger with copper tubes.
- Washable air filters.
- Multi-direction air deflectors.
- Optional Electric Heat Available

NEW SIZES: 42,000 - 60,000 Btuh (50/60 Hz)

Features:

- Convertible Installation — Ceiling or Low Wall
- Convenient Factory Wired Control
- Optional Wireless Remote Control
- Three-Speed Fan
- Ideal for the light Commercial Application
- Optional Electric Heat Available

Control :

Microprocessor

- Automatic control of the room temperature.
- Anti-frost protection of the evaporator coil.
- De-frosting by cycle reversal (heating mode).
- Operation is possible without remote control.

Infrared remote control with :

- Liquid crystal display.
- Selection of heating, cooling, heating/cooling and fan only.
- Selection of 3 fan speeds or automatic ventilation.
- Delayed start/stop.

New MWX, Match it with TWJ / 2TWB / TWA / 2TWA

220-240/1/50 or 200-240/1/60

Models		Air Flow		Nominal Capacity		Heating		Electric Heat
Cooling	Heat Pump	cmh	cfm	kW	MBh	kW	MBh	kW
MCX512E	MWX512E	510	300	3.5	12	4.1	14	2
MCX518E	MWX518E	765	450	5.3	18	4.7	16	2.5
MCX524E	MWX524E	1020	600	7.0	24	6.2	21	3.5
MCX530E	MWX530E	1275	750	8.8	30	8.8	30	5
MCX536E	MWX536E	1530	900	10.5	36	9.4	32	5
MCX042E	MWX042E	1785	1050	12.3	42	11.4	39	5
MCX048E	MWX048E	2040	1200	14.1	48	11.7	40	6
MCX060E	MWX060E	2550	1500	17.5	60	15.5	53	7

* Rated at 27/19° C DB/WB and 35° C ODB

+ Rated at 20° C DB and 6° C ODB

Dimensions (mm) and weight (kg)

MCX/MWX indoor units

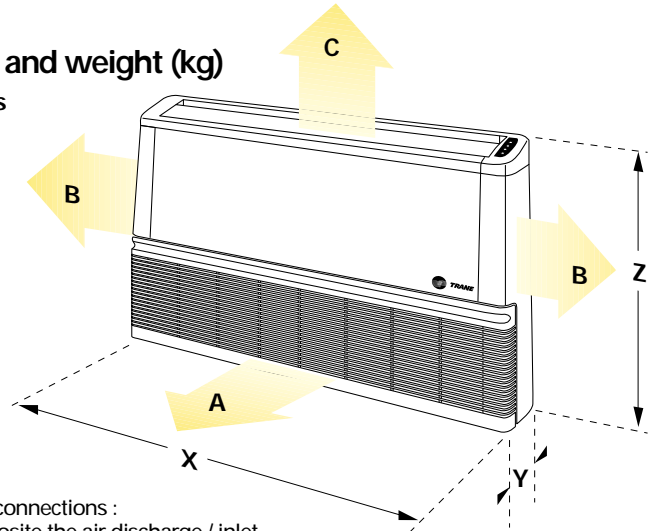

Cooling line and electrical connections :
to the right of the unit, opposite the air discharge / inlet.

Models		Dimensions (mm)			Clearance (mm)			Net weight (kg)
Cooling	Reversible	X	Y	Z	A	B	C	
MCX512E	MWX512E	1085	243	627	500	300	500	33
MCX518E	MWX518E	1085	243	627	500	300	500	36
MCX524E	MWX524E	1335	268	627	500	300	500	41
MCX530E	MWX530E	1585	268	627	500	300	500	50
MCX536E	MWX536E	1585	268	627	500	300	500	57
MCX042E	MWX042E	1835	268	627	500	300	500	72
MCX048E	MWX048E	1835	268	627	500	300	500	75
MCX060E	MWX060E	2085	268	627	500	300	500	84